

[54] LARGE APERTURE EXTENDED RANGE ZOOM LENS

[75] Inventor: Andor A. Fleischman, Northbrook, Ill.

[73] Assignee: Bell & Howell Company, Chicago, Ill.

[21] Appl. No.: 871,675

[22] Filed: Jan. 23, 1978

Related U.S. Patent Documents

Reissue of:

[64] Patent No.: 4,062,621
 Issued: Dec. 13, 1977
 Appl. No.: 704,595
 Filed: Jul. 12, 1976

U.S. Applications:

[63] Continuation-in-part of Ser. No. 625,965, Oct. 28, 1975, abandoned.

[51] Int. Cl.² G02B 15/18

[52] U.S. Cl. 350/423
 [58] Field of Search 350/184-187

[56] References Cited

U.S. PATENT DOCUMENTS

2,937,572	5/1960	Yamaji	350/184
3,360,325	12/1967	Gustafson	350/184
3,773,402	11/1973	Gela et al.	350/184
3,784,285	1/1974	Watanabe	350/184
3,885,862	5/1975	Fujidka et al.	350/186
3,972,591	8/1976	Suwa	350/184

Primary Examiner—Conrad J. Clark
 Attorney, Agent, or Firm—Harold V. Stotland; Roger M. Fitz-Gerald

[57] ABSTRACT

Disclosed is an optical design for a variable focal length lens of large effective aperture which is focusable over an extended range including the "macro" range and is provided with a high degree of correction.

5 Claims, 33 Drawing Figures

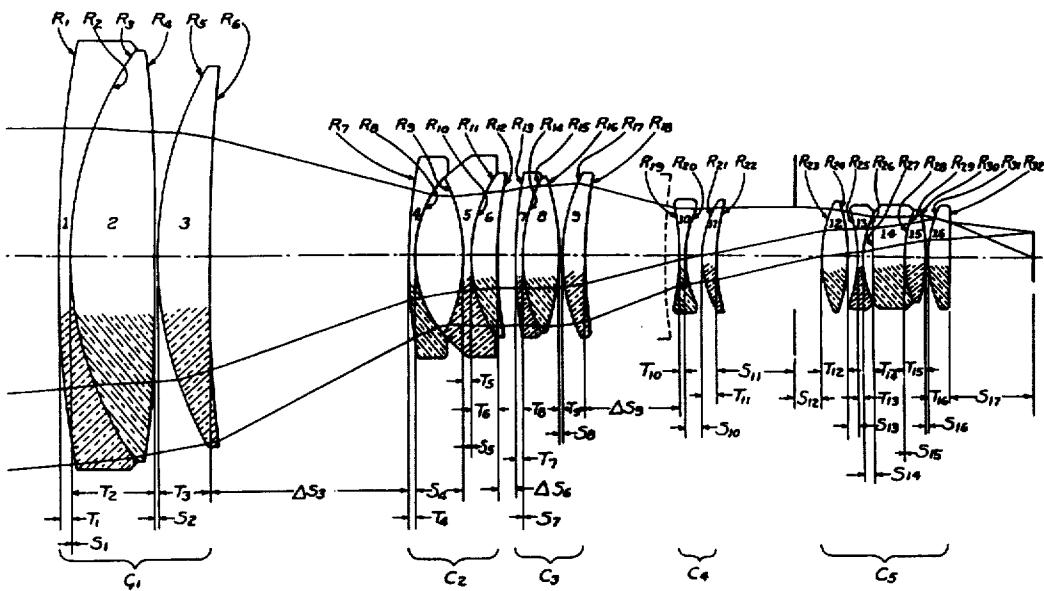
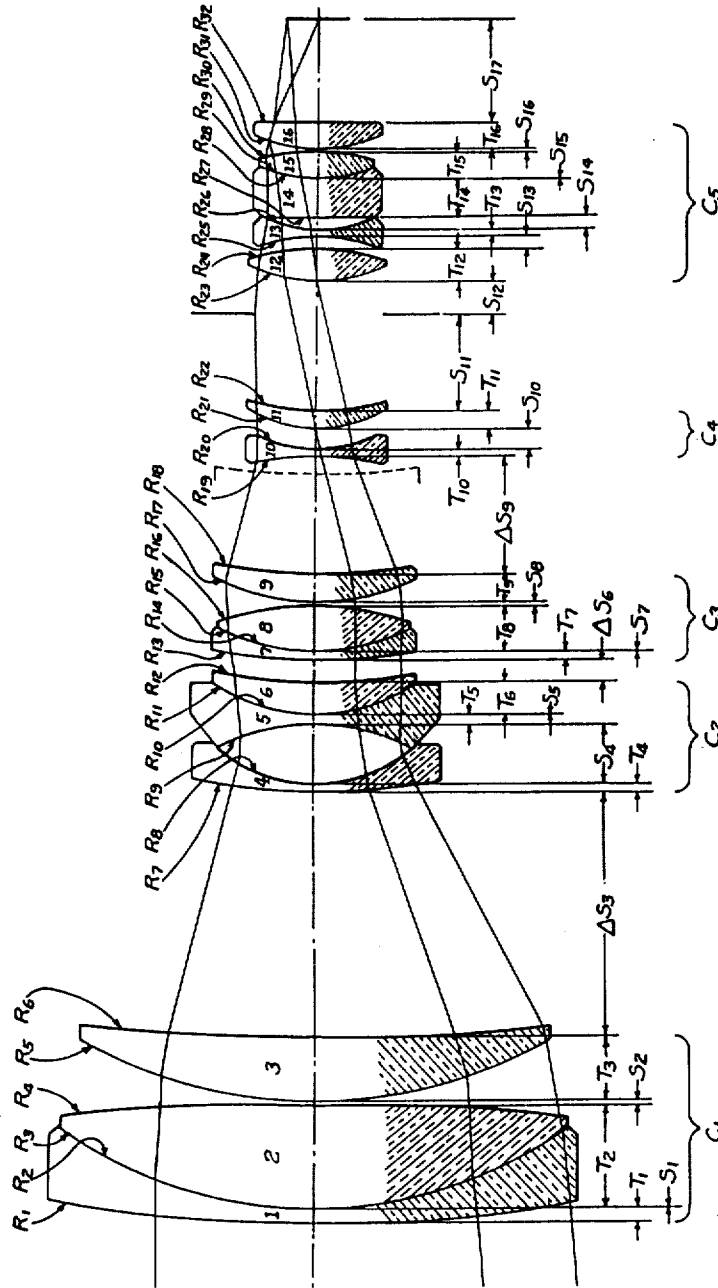
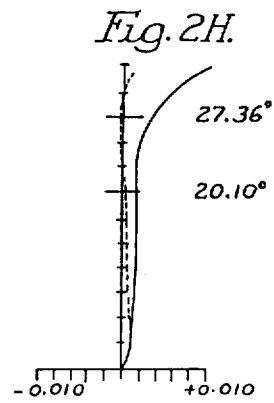
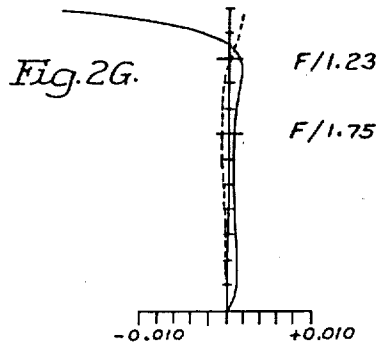
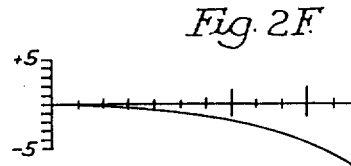
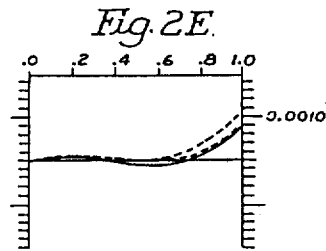
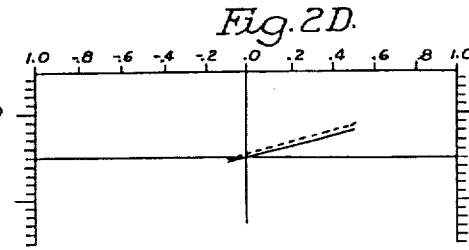
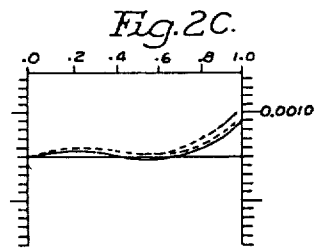
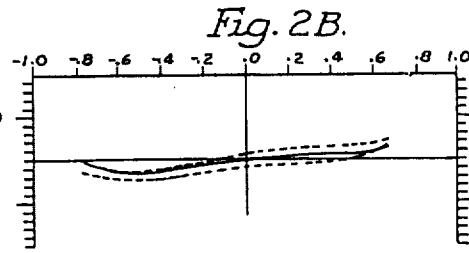
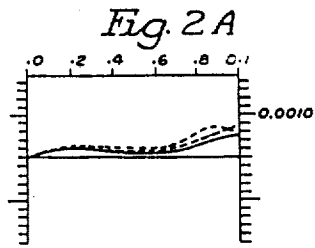
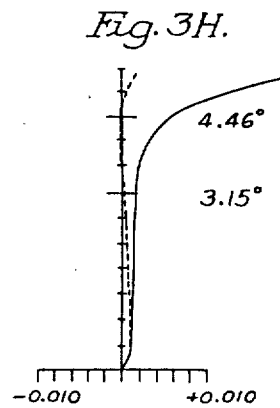
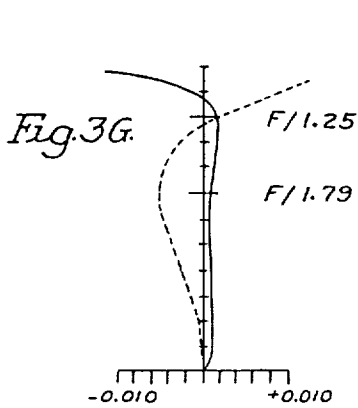
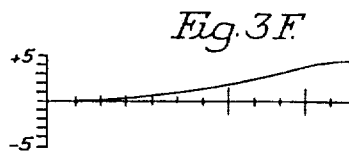
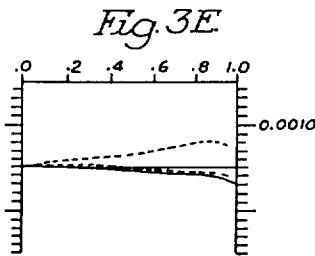
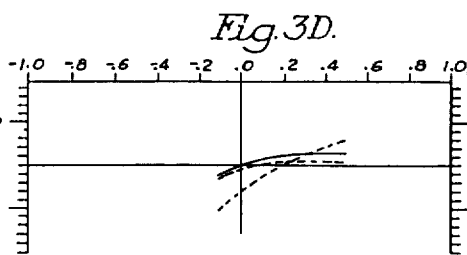
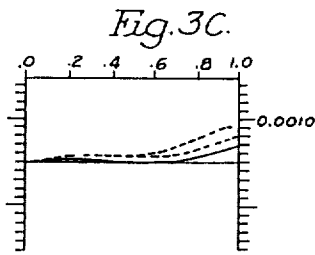
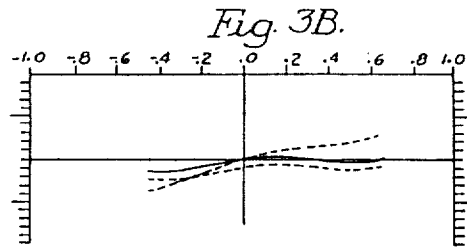
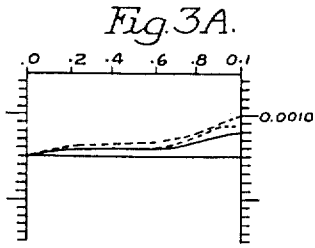

Fig. 1.







LARGE APERTURE EXTENDED RANGE ZOOM LENS

Matter enclosed in heavy brackets [] appears in the original patent but forms no part of this reissue specification; matter printed in italics indicates the additions made by reissue.

This application is a continuation-in-part of Ser. No. 625,965 filed Oct. 28, 1975, and now abandoned.

Another such lens is disclosed in the present applicant's U.S. Pat. application Ser. No. 944,341, filed Sept. 21, 1978.

This invention relates to a variable focal length lens of large effective aperture, and more particularly to a variable focal length lens, focusable over an extended range, and highly corrected over a large range of magnification.

Many zoom lenses or variable equivalent focal length lenses have been designed having moderate effective apertures insofar as they are desired to be competitive with the existing market of photographic equipment, such as motion picture cameras. Recently, another generation of zoom lenses has been designed having unusually large apertures in the $f/1.2$ class. Generally, these lenses have had magnification ratios not exceeding three-to-one. Thus, the benefit of the high effective aperture has been offset against a low magnification ratio. Other lenses of lesser apertures, although of similar or slightly greater magnification ratios to the high aperture lenses, have been designed for focusing in a range of less than the normal range of approximately 1 meter to infinity. This less than normal focusing range, enabling focusing from several millimeters from the lens to the closest distance of the normal range, is referred to as the "Macro" range. Most lenses with a high aperture [of] or a high magnification ratio are not capable of maintaining the required high degree of correction when focusing in the macro range. Hence, only a few relatively special, and therefore generally expensive lenses have been designed and are available having the combination of features incorporated in the present lens design. Also, because of the expense of these lenses, most have not been competitive so as to receive acceptance in the mass market by the "home" movie makers.

[Another] An object of the invention is to provide a relatively compact and relatively inexpensive zoom lens highly corrected over a magnification range greater than the more conventional three-to-one range from zoom lens of comparable large effective apertures.

It is to be understood that the terms "front" and "rear" as used herein refer to the ends of the objective respectively nearer the long and short conjugates thereof.

Other objects and advantages of the invention will become apparent from the detailed description which follows when taken in conjunction with the accompanying drawings in which:

FIG. 1 is a diagrammatic sectional view of a preferred optical system according to the present invention;

FIGS. 2A to 2H are graphical representations of the various aberrations of the lens system shown in FIG. 1 and having the design data given in Table 1 in the wide angle mode; and

FIGS. 3A to 3H are similar graphical representations of the lens system aberrations in the telephoto mode.

[FIGS. 4A to 4H are graphical representations of the various aberrations of the lens system having the design data given in Table 2 when in the wide angle mode.]

[FIGS. 5A to 5H are similar graphical representations of the Table 2 lens system when in the telephoto mode.]

Referring to the drawings, a zoom lens or variable equivalent focal length objective lens is shown. Particularly, the lens is highly corrected over a relatively large magnification range, and is capable of focus in the macro range as well as the normal range. Further, the lens has a relatively large effective aperture when compared to other lens designs having [the] a zoom range.

The lens includes a positive first component C_1 , starting at the ray entrance side of the optical system, which component is adjustable axially through a short distance for focusing of the optical system throughout a range of approximately 1 meter to infinity. Component C_2 is a variator or negative component variable along the axis of the optical system for varying the equivalent focal length of the objective. The equivalent focal length is variable over greater than a six-to-one range of magnification while maintaining a high degree of optical correction for a large aperture of at least $f/1.2$ throughout the range. Component C_3 is a component adjustable axially upon axial adjustment of the variator, to function as a compensator for correcting aberrations caused by varying the focal length of the optical system, and being [independently] adjustable for focusing of the optical system in the macro range. Component C_4 is a fixed lens member for further collimating rays exiting the compensator component C_3 . Rear component C_5 is a prime lens group forming an afocal system with the earlier described components.

The front component C_1 , comprises a front biconvex cemented doublet L_1, L_2 , and a rear singlet L_3 , predominately convex forwardly and spaced close to the doublet L_1, L_2 . Air spaced from the rear of the singlet L_3 and adjustable relative thereto is component C_2 which comprises a front negative meniscus singlet L_4 convex forwardly and a rear biconcave, cemented doublet L_5, L_6 predominately concave forwardly. The doublet has collective internal contact surfaces R_{10}, R_{11} .

Component C_3 is variably air spaced relative to component C_2 and the following component C_4 . Component C_3 comprises a positive doublet L_7, L_8 predominately convex rearwardly. During a zooming or focal length varying operation, the component C_3 is moved axially at a rate proportional to the rate of movement of component C_2 . However, for macro focusing action, the driver (not shown) of the components C_2 and C_3 by which axial adjustment thereof is accomplished is disconnected. [from component C_2 to cause that component to remain stationary while component C_3 is adjusted axially for focusing.]

Component C_4 is fixed ahead of the stop of the optical system and comprises a front negative meniscus singlet L_{10} and a rear positive meniscus singlet L_{11} which together form a substantially afocal system cooperating with the rear prime lens system C_5 .

Component C_5 comprises a front biconvex singlet L_{12} , spaced somewhat from a negative element L_{13} . A doublet of elements L_{14} and L_{15} is arranged between element L_{13} and rear element L_{16} which is a singlet predominately convex forwardly.

The [element] elements L_1 to L_{16} have spherical surfaces or radii of curvature R_1 to R_{32} , axial thicknesses T_1 to T_{15} and axial separations S_1 to S_{14} . The separations

at S_{11} and S_{12} are sufficient to provide clearance for an aperture adjusting stop.

A preferred embodiment of the macro focusing, large aperture, zoom lens of the invention is constructed according to the table following wherein dimensions are as set forth and the refractive indices for the sodium D line and the Abbe dispersion numbers are respectively designated at N_D and V .

spacings between the respective elements, and the nominal image plane. EFL is the effective focal length of the lens system at wide angle condition W/A, at telephoto condition T/P, and at mid range condition MID. "One-half Angle of Field" is one half the angle between the continuation of the lens axis and a line from the nodal point of the lens to the most oblique point recorded on the film when considered at the

TABLE 1

LENS	SYSTEM EFL		HALF ANGLE OF FIELD		
	at W/A = 7.22mm (.2835 in.)		27.36°		
at T/P = 43.86mm (1.7268 in.)		4.46°			
at MID = 19.25mm (.7579 in.)		10.02°			
	RADII (mm.)	THICKNESS (mm)	SPACINGS (mm)	N_D	V
1	$R_1 = 166.0901$ $R_2 = -45.7200$	$T_1 = 1.702$		1.755	27.6
2	$R_3 = 45.7200$ $R_4 = 233.4001$	$T_2 = 11.430$	$S_1 = 0$	1.623	56.9
3	$R_5 = 50.3428$ $R_6 = -301.7523$	$T_3 = 7.112$	$S_2 = .1016$	1.651	56.2
4	$R_7 = 70.3580$ $R_8 = -16.8656$	$T_4 = 0.800$	$S_3 = 1.4910$ at W/A 27.1882 at T/P 17.7851 at MID	1.639	55.4
5	$R_9 = -24.0030$ $R_{10} = -19.1008$	$T_5 = 0.800$	$S_4 = 6.584$	1.620	60.3
6	$R_{11} = 19.1008$ $R_{12} = -59.9948$	$T_6 = 3.556$	$S_5 = 0$	1.785	25.7
7	$R_{13} = 53.9750$ $R_{14} = -21.3106$	$T_7 = 0.800$	$S_6 = 38.3210$ at W/A 2.7508 at T/P 17.1018 at MID	1.805	25.4
8	$R_{15} = 21.3106$ $R_{16} = 31.6230$	$T_8 = 5.121$	$S_7 = 0$	1.640	60.2
9	$R_{17} = 23.2664$ $R_{18} = -101.5237$	$T_9 = 3.150$	$S_8 = .1016$	1.691	54.8
10	$R_{19} = -45.5168$ $R_{20} = -12.8016$	$T_{10} = 0.711$	$S_9 = 1.7348$ at W/A 11.6103 at T/P 6.6573 at MID	1.691	54.8
11	$R_{21} = 14.6431$ $R_{22} = -27.4320$	$T_{11} = 2.091$	$S_{10} = 2.2758$	1.805	25.4
12	$R_{23} = 17.2720$ $R_{24} = 30.4292$	$T_{12} = 3.226$	$S_{11} = 10.668$ STOP $S_{12} = 3.556$	1.774	44.8
13	$R_{25} = -19.3040$ $R_{26} = -17.1196$	$T_{13} = 0.711$	$S_{13} = 1.6764$	1.805	25.4
14	$R_{27} = 173.1519$ $R_{28} = -16.5100$	$T_{14} = 4.496$	$S_{14} = .8890$	1.805	25.4
15	$R_{29} = 16.5100$ $R_{30} = 21.8034$	$T_{15} = 2.794$	$S_{15} = 0$	1.744	44.8
16	$R_{31} = 14.9758$ $R_{32} = -424.1817$	$T_{16} = 3.023$	$S_{16} = .1270$ $S_{17} = 11.277$ BFL	1.734	51.5

In the Table 1 above, the first column lists the lens elements numerically starting at the ray entrance side of the system. The second column lists the respective radii of the elements in millimeters. The third column lists the axial thickness T of the respective elements in millimeters. The fourth column lists in millimeters the axial

above expressed conditions.

FIGS. 2A to 2H graphically represent various aberrations of the form of the optical system, as shown in FIG. 1 and having the design data recited in Table 1. FIG. 2A represents correction of the rays on axis. FIG. 2B represents off axis aberrations of rays passing from the zone

of the film format and through the lens transversely and tangentially. FIG. 2C represents the aberrations of the rays passing from the corner of the film format through the lens tangentially and transversely. FIG. 2D represents the radial or longitudinal aberrations from the zone of the film format of rays entering the lens at 3 o'clock, while FIG. 2E represents similar aberrations from full field or corner rays. FIG. 2F represents distortion as a percentage of a "perfect" image. FIG. 2G represents the spherical aberrations by a full line and the offense-against-sine condition by the dotted line. FIG. 2H represents the curvature of field with tangential curvature being shown in full line and sagittal curvature being shown in dashed line.

FIGS. 3A to 3H graphically represent various aberrations of the optical system with the lens adjusted to the telephoto condition, as opposed to the wide angle con-

dition as represented in FIGS. 2A to 2H. In FIGS. 2A to 2E and 3A to 3E, the solid line represents the aberrations of a light ray at 5893 Å, the dotted line represents a light ray at 6563 Å, and the dashed line a light ray at 4861 Å.

【The design data of another embodiment of the optical system is shown in Table 2 set forth hereinafter. This optical system has a similar construction to the system shown in FIG. 1. FIGS. 4A to 4H, and FIGS. 5A to 5H graphically represent various aberrations related to the form of the optical system as described in the data of Table 2. The graphs in FIGS. 4A to 4H relate to the wide angle condition of the optical system, while the graphs of FIGS. 5A to 5H relate to the telephoto condition. The aberrations are identified with respect to FIGS 2A to 2H.】

【TABLE 2

LENS	SYSTEM EFL		HALF ANGLE OF FIELD		
	at W/A = 7.61mm (2.997 in.)		25.35°		
at T/P = 56.98mm (2.2433 in.)		3.31°			
at MID = 25.67mm (1.0105 in.)		7.58°			
RADII (mm.)	THICKNESS (mm.)	SPACINGS (mm)	N _D	V	
R ₁ = 240.7589 R ₂ = -51.1988	T ₁ = 1.6510	S ₁ = 0	1.755	27.6	
R ₃ = 51.1988 R ₄ = 152.7810	T ₂ = 12.7000	S ₂ = .1016	1.620	60.4	
R ₅ = 43.6880 R ₆ = -139.7000	T ₃ = 7.7978	S ₃ = 4.2875 at W/A 29.5554 at T/P 22.3952 at MID	1.651	55.9	
R ₇ = 71.7550 R ₈ = -16.5100	T ₄ = .8128	S ₄ = 6.6294	1.639	55.4	
R ₉ = -24.0030 R ₁₀ = -19.1008	T ₅ = .8382	S ₅ = 0	1.620	60.4	
R ₁₁ = 19.1008 R ₁₂ = -59.9948	T ₆ = 3.5052	S ₆ = 38.4048 at W/A 2.5857 at T/P 14.2570 at MID	1.785	25.8	
R ₁₃ = 58.9280 R ₁₄ = -21.7424	T ₇ = .8890	S ₇ = 0	1.805	25.4	
R ₁₅ = 21.7424 R ₁₆ = 30.2260	T ₈ = 5.6388	S ₈ = .1016	1.641	60.1	
R ₁₇ = 22.7203 R ₁₈ = 93.1672	T ₉ = 3.1496	S ₉ = 1.6002 at W/A 12.1514 at T/P 7.6403 at MID	1.691	54.9	
R ₁₉ = -45.5168 R ₂₀ = -12.8016	T ₁₀ = .7112	S ₁₀ = 2.2352	1.691	54.9	
R ₂₁ = 16.6431 R ₂₂ = -27.0256	T ₁₁ = 2.0574	S ₁₁ = 11.0490 STOP S ₁₂ = 3.5560	1.805	25.4	
R ₂₃ = 18.0848 R ₂₄ = 32.8168	T ₁₂ = 3.6576	S ₁₃ = 1.6002	1.744	44.8	
R ₂₅ = -21.9202 R ₂₆ = -16.8656	T ₁₃ = .7112	S ₁₄ = .7336	1.805	25.4	
R ₂₇ = 61.2140 R ₂₈ = -14.5288	T ₁₄ = 4.3180	S ₁₅ = 0	1.805	25.4	
R ₂₉ = 14.5288 R ₃₀ = 26.9494	T ₁₅ = 3.2512	S ₁₆ = .1270	1.744	44.8】	

TABLE 2-continued

SYSTEM EFL		HALF ANGLE OF FIELD			
at W/A = 7.61mm (.2997 in.)		25.35°			
at T/P = 56.98mm (2.2433 in.)		3.31°			
at MID = 25.67mm (1.0105 in.)		7.58°			
LENS	RADII (mm.)	THICKNESS (mm.)	SPACINGS (mm)	N _D	V
16	R ₃₁ = 14.7320 R ₃₂ = -463.9259	T ₁₆ = 2.5654	S ₁₇ = 11.4529	1.734	51.7

What I claim is:

1. An optical system for a variable focal length lens of large effective aperture, which is focusable over an extended range, having substantially the following 15 specification:

SYSTEM EFL		HALF ANGLE OF FIELD			
at W/A = 7.22mm (.2835 in.)		27.36°			
at T/P = 43.86mm (1.7268 in.)		4.46°			
at MID = 19.25mm (.7579)		10.02°			
Lens	Radii(mm.)	Thickness (mm.)	Spacings(mm)	N _D	V
1	R ₁ = 166.0901 R ₂ = -45.7200	T ₁ = 1.702	S ₁ = 0	1.755	27.6
2	R ₃ = 45.7200 R ₄ = 233.4001	T ₂ = 11.430	S ₂ = .1016	1.623	56.9
3	R ₅ = 50.3428 R ₆ = -301.7523	T ₃ = 7.112	S ₃ = 1.4910 at W/A 27.1882 at T/P 17.7851 at MID	1.651	56.2
4	R ₇ = 70.3580 R ₈ = -16.8656	T ₄ = 0.800	S ₄ = 6.584	1.639	55.4
5	R ₉ = -24.0030 R ₁₀ = -10.1008	T ₅ = 0.800	S ₅ = 0	1.620	60.3
6	R ₁₁ = 19.1008 R ₁₂ = -59.9948	T ₆ = 3.556	S ₆ = 38.3210 at W/A 2.7508 at T/P 17.1018 at MID	1.785	25.7
7	R ₁₃ = 53.9750 R ₁₄ = -21.3106	T ₇ = 0.800	S ₇ = 0	1.805	25.4
8	R ₁₅ = 21.3106 R ₁₆ = 31.6230	T ₈ = 5.121	S ₈ = .1016	1.640	60.2
9	R ₁₇ = 23.2664 R ₁₈ = -101.5237	T ₉ = 3.150	S ₉ = 1.7348 at W/A 11.6103 at T/P 6.6573 at MID	1.691	54.8
10	R ₁₉ = -45.5168	T ₁₀ = 0.711		1.691	54.8

-continued

SYSTEM EFL		HALF ANGLE OF FIELD			
at W/A = 7.22mm (.2835 in.)		27.36°			
at T/P = 43.86mm (1.7268 in.)		4.46°			
at MID = 19.25mm (.7579)		10.02°			
Lens	Radii(mm.)	Thickness (mm.)	Spacings(mm)	N _D	V
20	R ₂₀ = -12.8016 R ₂₁ = 14.6431 R ₂₂ = -27.4320	T ₁₁ = 2.091	S ₁₀ = 2.2758 S ₁₁ = 10.668 --- STOP --- S ₁₂ = 2.556	1.805	25.4
12	R ₂₃ = 17.2720 R ₂₄ = 30.4292	T ₁₂ = 3.226	S ₁₃ = 1.6764	1.774	44.8
25	R ₂₅ = -19.3040 R ₂₆ = -17.1196	T ₁₃ = 0.711	S ₁₄ = .8890	1.805	25.4
14	R ₂₇ = 173.1519 R ₂₈ = -16.5100	T ₁₄ = 4.496	S ₁₅ = 0	1.805	25.4
15	R ₂₉ = 16.5100 R ₃₀ = 21.8034	T ₁₅ = 2.794	S ₁₆ = .1270	1.744	44.8
30	R ₃₁ = 14.9758 R ₃₂ = -424.1817	T ₁₆ = 3.023	S ₁₇ = 11.277 BFL	1.734	51.5

wherein the first column lists the lens elements numerically starting at the ray entrance side of the system; the second column lists the respective base radii R₁ to R₃₂; the third column lists the thicknesses T₁-T₁₆ of the respective elements; the fourth column lists the axial spacings S₁ to S₁₇ between the respective elements, and stop, and the image plane; and the fifth and sixth columns respectively list the index of refraction for the Sodium D line N_D and the dispersive index V of the optical materials of the respective elements.

2. An optical system for a variable focal length lens of large effective aperture, which is focusable over an extended range, having substantially the following specification:

SYSTEM EFL		HALF ANGLE OF FIELD			
at W/A = 7.61mm (.2997 in.)		25.35°			
at T/P = 56.98mm (2.2433 in.)		3.31°			
at MID = 25.67mm (1.0105 in.)		7.58°			
LENS	RADII (mm.)	THICKNESS (mm.)	SPACINGS (mm)	N _D	V
1	R ₁ = 240.7589 R ₂ = -51.1988	T ₁ = 1.6510	S ₁ = 0	1.755	27.6
2	R ₃ = 51.1988 R ₄ = 152.7810	T ₂ = 12.7000	S ₂ = .1016	1.620	60.4
3	R ₅ = 43.6880 R ₆ = -139.7000	T ₃ = 7.7978	S ₃ = 4.2875 at W/A 29.5554 at T/P 22.3952 at MID	1.651	55.9
4	R ₇ = 71.7550 R ₈ = -16.5100	T ₄ = .8128	S ₄ = 6.6294	1.639	55.4
5	R ₉ = -24.0030 R ₁₀ = -19.1008	T ₅ = .8382	S ₅ = 0	1.620	60.4
6	[R ₁₁ 19.1008]				

-continued

[SYSTEM EFL		HALF ANGLE OF FIELD			
at W/A = 7.61mm (.2997 in.)		25.35°			
at T/P = 56.98mm (2.2433 in.)		3.31°			
at MID = 25.67mm (1.0105 in.)		7.58°			
LENS	RADII (mm.)	THICKNESS (mm.)	SPACINGS (mm)	N _D	V
	R ₁₂ = -59.9948	T ₆ = 3.5052	S ₆ = 38.4048 at W/A 2.5857 at T/P 14.2570 at MID	1.785	25.8
7	R ₁₃ = 58.9280 R ₁₄ = -21.7424	T ₇ = .8890	S ₇ = 0	1.805	25.4
8	R ₁₅ = 21.7424 R ₁₆ = 30.2260	T ₈ = 5.6388	S ₈ = .1016	1.641	60.1
9	R ₁₇ = 22.7203 R ₁₈ = 93.1672	T ₉ = 3.1496	S ₉ = 1.6002 at W/A 12.1514 at T/P 7.6403 at MID	1.691	54.9
10	R ₁₉ = -45.5168 R ₂₀ = -12.8016	T ₁₀ = .7112	S ₁₀ = 2.2352	1.691	54.9
11	R ₂₁ = 16.6431 R ₂₂ = -27.0256	T ₁₁ = 2.0574	S ₁₁ = 11.0490 STOP S ₁₂ = 3.5560	1.805	25.4
12	R ₂₃ = 18.0848 R ₂₄ = 32.8168	T ₁₂ = 3.6576	S ₁₃ = 1.6002	1.744	44.8
13	R ₂₅ = -21.9202 R ₂₆ = -16.8656	T ₁₃ = .7112	S ₁₄ = .7336	1.805	25.4
14	R ₂₇ = 61.2140 R ₂₈ = -14.5288	T ₁₄ = 4.3180	S ₁₅ = 0	1.805	25.4
15	R ₂₉ = 14.5288 R ₃₀ = 26.9494	T ₁₅ = 3.2512	S ₁₆ = .1270	1.744	44.8
16	R ₃₁ = 14.7320 R ₃₂ = -463.9259	T ₁₆ = 2.5654	S ₁₇ = 11.4529	1.734	51.7

wherein the first column lists the lens elements numerically starting at the ray entrance side of the system; the second column lists the respective base radii R₁ to R₃₂; the third column lists the thicknesses T₁-T₁₆ of the respective elements; the fourth column lists the axial spacings S₁ to S₁₇ between the respective elements, and stop, and the image plane; and the fifth and sixth columns respectively list the index of refraction for the Sodium D line N_D and the dispersive index V of the optical materials of the respective elements.】

3. An optical system for a variable focal length lens which is focusable over an extended range defined by a first range portion for normal object distances and a second range portion for shorter object distances, said optical system comprising:

- a focusing component including first and second elements arranged into a positive doublet, and a positive third element;
- a variator component including a negative fourth element, and fifth and sixth elements arranged into a negative doublet;
- a compensator component including seventh and eighth elements arranged into a positive doublet, and a positive ninth element;
- a collimator component including

- 40 a negative tenth element, and a positive eleventh element; and
- a prime lens component including a positive twelfth element, a negative thirteenth element, 45 fourteenth and fifteenth elements arranged into a positive doublet, and a positive sixteenth element; all of said elements being located on a common optical axis and following one another in the order set forth; said focusing component being movable for focusing said optical system over said first range portion; said variator component being movable for variation of the focal length of said optical system; said compensator component being movable relative to said variator component for focusing of said 50 optical system over said second range portion.
- 55 4. An optical system for a variable focal length lens which is focusable over an extended range defined by a first range portion for normal object distances and a second range portion for shorter object distances, said optical system comprising:
 - a focusing component including first and second elements arranged into a positive doublet, said first element being a negative meniscus and said second element being biconvex, and a positive meniscus third element;
 - a variator component including a negative meniscus fourth element, and

11

12

fifth and sixth elements arranged into a negative doublet, said fifth element being biconcave and said sixth element being a positive meniscus;

a compensator component including seventh and eighth elements arranged into a positive doublet,

said seventh element being a negative meniscus and said eighth element being biconvex, and a positive meniscus ninth element;

a collimator component including a negative biconcave tenth element, and a positive meniscus eleventh element; and

a prime lens component including a positive biconvex twelfth element, a negative biconcave thirteenth element, fourteenth and fifteenth elements arranged into a positive doublet,

said fourteenth element being a negative meniscus and said fifteenth element being biconvex, and a positive sixteenth element;

all of said elements being located on a common optical axis and following one another in the order set forth; said focusing component being movable for focusing said optical system over said first range portion; said variator component being movable for variation of the focal length of said optical system; said compensator component being movable relative to said variator component for focusing of said optical system over said second range portion.

5. An optical system for a variable focal length lens which is focusable over an extended range defined by a first range portion for normal object distances and a second range portion for shorter object distances, said optical system comprising:

a focusing component including first and second elements arranged into a positive doublet, and

a positive third element;

a variator component including a negative fourth element, and fifth and sixth elements arranged into a negative doublet;

a compensator component including seventh and eighth elements arranged into a positive doublet, and

a positive ninth element;

a collimator component including

5

10

15

20

25

30

35

40

45

50

55

60

65

a negative tenth element, and a positive eleventh element; and a prime lens component including

a positive twelfth element, a negative thirteenth element, fourteenth and fifteenth elements arranged into a positive doublet, and a positive sixteenth element;

all of said elements being located on a common optical axis and following one another in the order set forth.

6. An optical system for a variable focal length lens which is focusable over an extended range defined by a first range portion for normal object distances and a second range portion for shorter object distances, said optical system comprising:

a focusing component including first and second elements arranged into a positive doublet,

said first element being a negative meniscus and said second element being biconvex, and a positive meniscus third element;

a variator component including a negative meniscus fourth element, and fifth and sixth elements arranged into a negative doublet,

said fifth element being biconcave and said sixth element being a positive meniscus;

a compensator component including seventh and eighth elements arranged into a positive doublet,

said seventh element being a negative meniscus and said eighth element being biconvex, and a positive meniscus ninth element;

a collimator component including a negative biconcave tenth element, and a positive meniscus eleventh element; and

a prime lens component including a positive biconvex twelfth element, a negative biconcave thirteenth element, fourteenth and fifteenth elements arranged into a positive doublet,

said fourteenth element being a negative meniscus and said fifteenth element being biconvex, and a positive sixteenth element;

all of said elements being located on a common optical axis and following one another in the order set forth.

* * * * *

UNITED STATES PATENT AND TRADEMARK OFFICE
CERTIFICATE OF CORRECTION

PATENT NO. : Re. 30,592
DATED : April 28, 1981
INVENTOR(S) : Andor A. Fleischman

It is certified that error appears in the above-identified patent and that said Letters Patent are hereby corrected as shown below:

Cover Sheet, Column 2, last line, change "33" to --17--;
Column 6, line 3, change "5893 A" to --5893 Å--;
Column 6, line 4, change "6563 A" to --6563 Å--;
Column 6, line 5, change "4861 A" to --4861 Å--;
Claim 1, Column 7, line 18, change "ELF" to --EFL--;
Claim 1, Column 7, line 21, change "(.7579)" to --(.7579 in.)--;
Claim 1, Column 8, line 13, change "ELF" to --EFL--;
Claim 1, Column 8, line 16, change "(.7579)" to --(.7579 in.)--;
Claim 1, Column 8, line 22, change $S_{12}=2.556$ " to -- $S_{12}=3.556$ --.

Signed and Sealed this

Twelfth Day of January 1982

[SEAL]

Attest:

GERALD J. MOSSINGHOFF

Attesting Officer

Commissioner of Patents and Trademarks