

L. J. KNOWLES.  
Mechanism for Operating Drop-Shuttle Boxes for Looms.

No. 221,237.

Patented Nov. 4, 1879

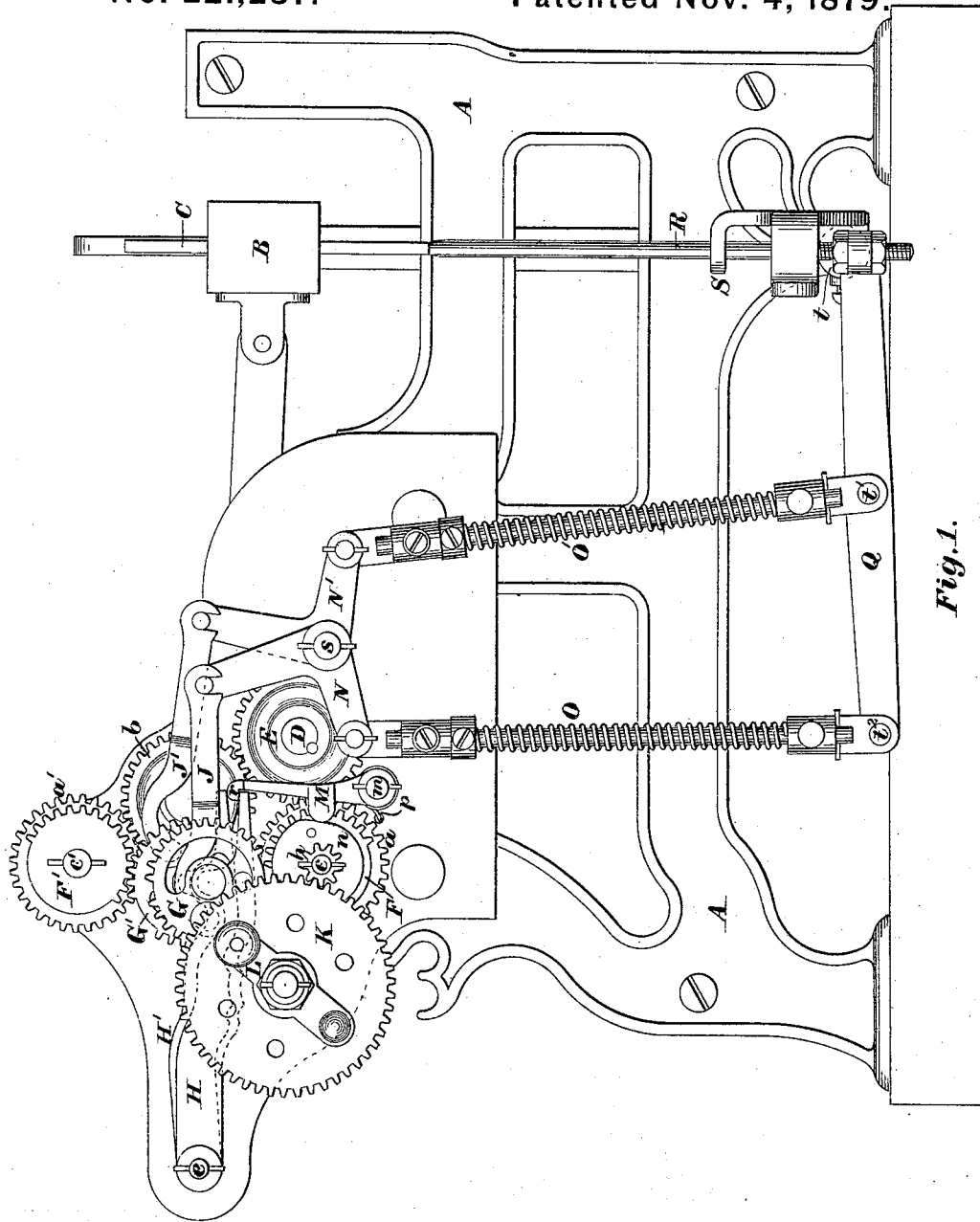

Witnesses:  
M. W. Swan  
H. G. Olmsted

Inventor:  
Lucius J. Knowles

L. J. KNOWLES.  
Mechanism for Operating Drop-Shuttle Boxes for Looms.

No. 221,237.

Patented Nov. 4, 1879.

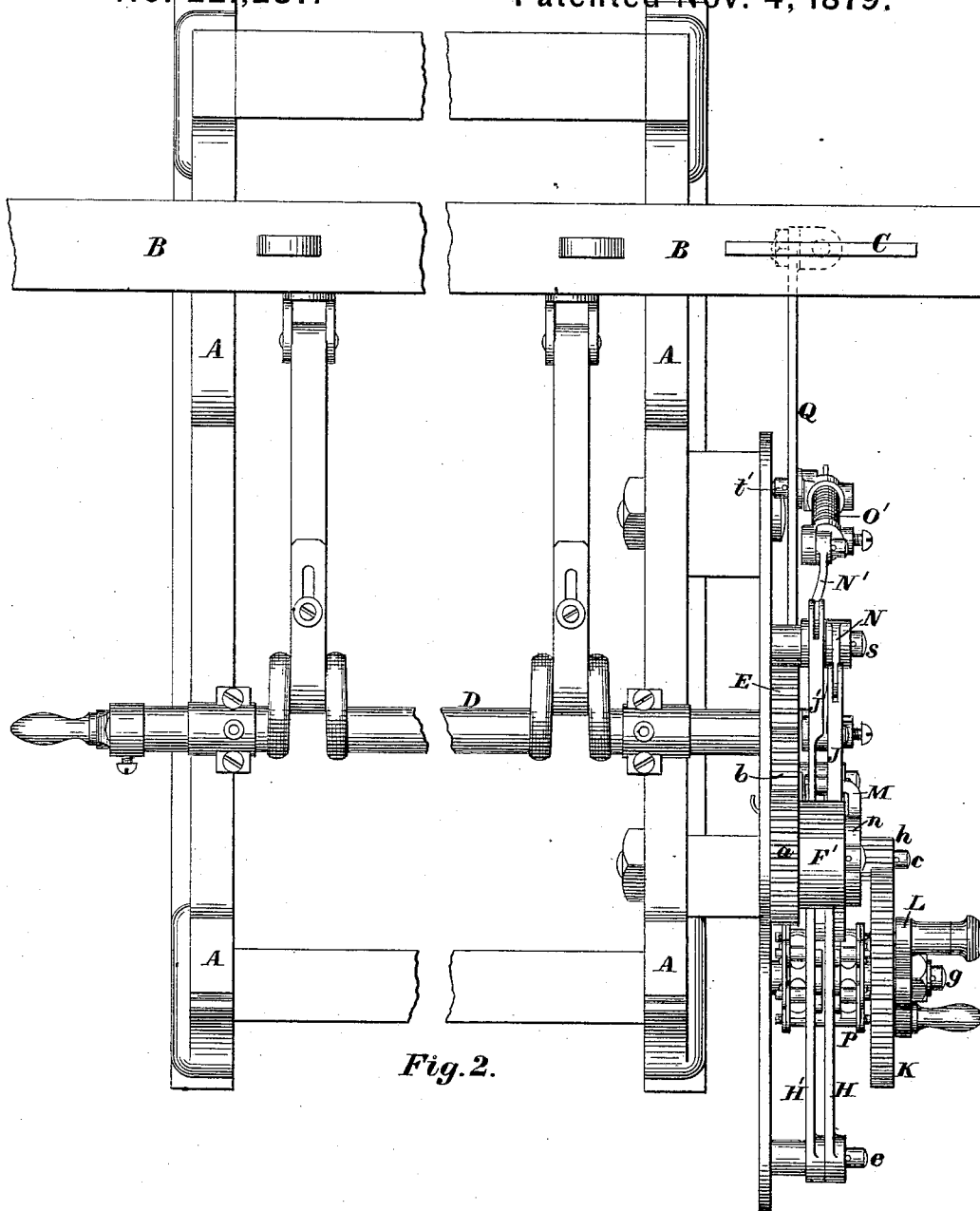

Fig. 2.

Witnesses:

W. W. Swan  
H. A. Olmsted

Inventor:

Lewis J. Knowles

L. J. KNOWLES.  
Mechanism for Operating Drop-Shuttle Boxes for Looms.

No. 221,237.

Patented Nov. 4, 1879.

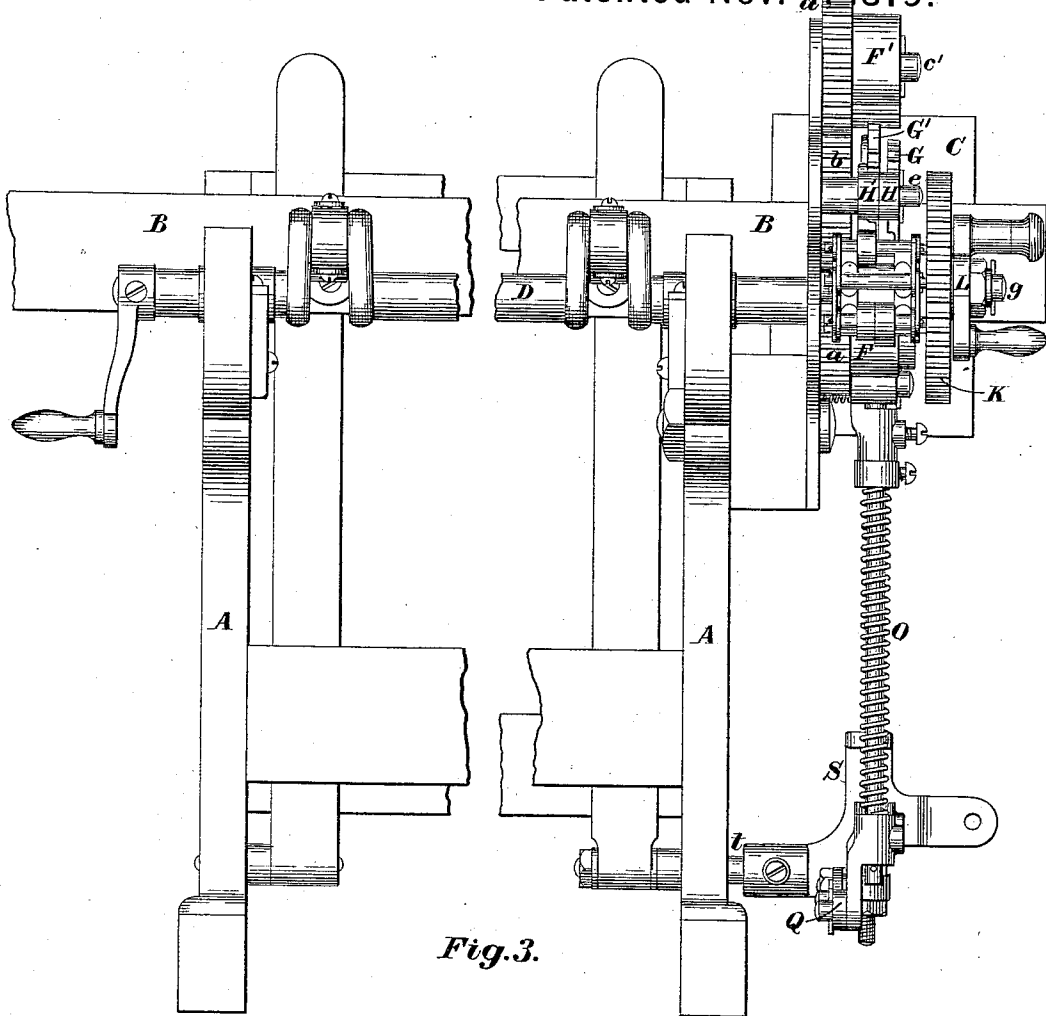

Fig. 3.

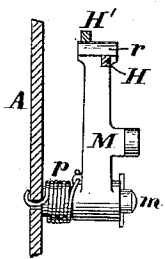

Fig. 6.

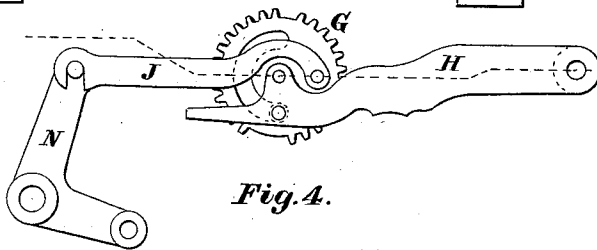

Fig. 4.

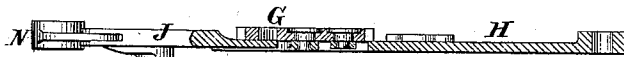

Fig. 5.

Witnesses:  
W. W. Swan  
H. K. Olmsted

Inventor:  
Lucius J. Knowles

# UNITED STATES PATENT OFFICE.

LUCIUS J. KNOWLES, OF WORCESTER, MASSACHUSETTS.

IMPROVEMENT IN MECHANISMS FOR OPERATING DROP SHUTTLE-BOXES FOR LOOMS.

Specification forming part of Letters Patent No. **221,237**, dated November 4, 1879; application filed May 19, 1879.

*To all whom it may concern:*

Be it known that I, LUCIUS J. KNOWLES, of Worcester, in the State of Massachusetts, have invented a new and useful Improvement in Mechanisms for Operating Drop Shuttle-Boxes for Looms, of which the following is a specification.

This invention is one of a number of modifications which I have made of the mechanism formerly employed by me for operating drop shuttle-boxes in the well-known looms bearing my name. These several modifications, being independent each of the others, form the subject-matters of several applications which I am now making for Letters Patent. It is, however, unnecessary for me to here describe the general features of my looms, or of looms to which this invention is applicable, since such looms are well known to those skilled in the art; and therefore in the present description I shall make little or no reference to other portions of the loom than those which are essential to the raising or lowering of the shuttle-boxes.

In the drawings, Figure 1 is an end elevation, showing the frame of a loom and so much of the mechanism as is necessary to illustrate my invention. Fig. 2 is a plan of the same. Fig. 3 is a rear elevation of the same. Figs. 4, 5, and 6 are details, which will be herein-after explained.

A is the frame. B is the lay. C represents a tier of four boxes, working up and down through a slot in the lay in the ordinary manner. D is the crank-shaft, from which motion is communicated to the lay, as shown. It also communicates motion to the shuttle-box mechanism as follows: At one end it carries a gear, E, whose teeth take into teeth upon a gear, *a*, rigidly attached to the lower cylinder-gear, F, which revolves upon a shaft, *c*, projecting from the frame. The teeth upon the gear E also take into teeth upon an intermediate gear, *b*, whose teeth take likewise into a gear, *a'*, rigidly attached to the upper cylinder-gear, F', which revolves on a shaft, *c'*, also projecting from the frame.

The cylinder-gears have teeth, as usual, over about half of their peripheries, and, according to the description just given, revolve constantly in opposite directions. In most instances,

however, I prefer to place the cylinder-gears much higher in the frame relatively to the crank-shaft, and to communicate motion to them from that shaft by means of an upright shaft and bevel-gears.

G G' are the vibrator-gears, loosely riveted to the vibrator-levers H H', which are pivoted to the frame at *e*. P is the pattern-wheel, and J J' are the connectors, all constructed and operated as in the well-known Knowles loom, the vibrator-gears having each two sets of teeth, one to mesh with the teeth of the upper cylinder-gear, and the other to mesh with the teeth of the lower cylinder-gear. The pattern-wheel P runs under the vibrator-levers on a sleeve upon a stud, *g*, in the frame, motion being imparted to it from the lower cylinder-gear, F, by a gear, *h*, rigidly attached to the lower cylinder-gear, and taking into a gear, K, loose on said sleeve, but having holes into which springs a catch-bolt in the end of arm L, which is fast to said sleeve, this contrivance not differing essentially from pattern mechanism shown and described in patent to me No. 134,992.

M is a swinging arm pivoted to the frame at *m*, and operated by the cam *n*, rigidly attached to lower cylinder-gear, F, being held against said cam by force of the spring *p*. At the upper end of the swinging arm M is a projection, *r*, which, by force of the spring *p*, catches over the projecting ends of the vibrator-levers to hold them down, excepting when prevented by cam *n* once in each revolution of said cam. The outer ends of the connectors J J' are, respectively, pivoted, as shown, to two bell-crank levers, N N', which are hinged or fulcrumed in reverse directions, as shown, to a stud, *s*, projecting from the frame. The bell-crank levers N and N' are connected, as shown, by connecting-rods O O' with a bar or lever, Q, which is pivoted to the shuttle-box rod R, which slides up and down in ways S, and carries on its upper end the tier of shuttle-boxes C, the said ways S being pivoted to the frame at *t* and rocking with the lay, as shown.

From the description just given it will be seen that the bar Q acts as a lever of the first or second kind to lift the rod R, accordingly as it is operated by the bell-crank lever N and

connecting-rod O, or the bell-crank lever N' and connecting-rod O'. In the former case the pivot *t'* is the fulcrum upon which the lever moves, while in the latter case the pivot *t* is the fulcrum—that is, the lever, by whichsoever connecting-rod operated, has for its fulcrum the pivot at the bottom of the other connecting-rod; and the two pivots are so placed relatively to each other that when the upper arm of the bell-crank lever N is drawn back toward its vibrator-gear the rod R is lifted a distance equal to one box, and when bell-crank lever N' is drawn back the rod R is lifted a distance equal to two boxes.

The connecting-rods O O' swing on pivots at either end; but the ways S convert their motion into one of a constant direction. It follows that a movement of the shuttle-box rod from any stated position may be obtained for a distance equal to one, two, or three boxes.

I have described the connecting-rods O and O' as pivoted directly to the bell-crank lever and the lever Q. This might be the construction; but as a safeguard against accidents the construction actually shown in the drawings should be followed. As shown in the drawings, the end of each connecting-rod is in a socket which is pivoted to its bell-

crank lever or the lever Q, as the case may be, the connecting-rod being rigidly secured to the socket at the end next the bell-crank lever and slipping freely in the other, although prevented from coming out by a pin, as shown. A spring is coiled around each connecting-rod of sufficient force to cause the pivot below to perform its proper office as a fulcrum, but weak enough to take up any extra resistance offered by the bell-crank lever above through disarrangement of mechanism or otherwise.

It is obvious that the contrivance herein described for raising or lowering the tier of shuttle-boxes at one end of the loom is to be duplicated for the tier of shuttle-boxes at the other end with unimportant modifications.

I claim—

The bell-crank levers N N', connecting-rods O O', bar Q, shuttle-boxes C, lifting-rod R, and ways S, in combination with the connectors J J' and mechanism for operating the latter, substantially as described, for the purpose specified.

LUCIUS J. KNOWLES.

Witnesses:

WILLIAM W. SWAN,  
H. G. OLMSTED.