



US 20130160480A1

(19) **United States**

(12) **Patent Application Publication**  
**Athanasίου et al.**

(10) **Pub. No.: US 2013/0160480 A1**

(43) **Pub. Date: Jun. 27, 2013**

(54) **ICE MAKER COMPRISING SUPPORT MEANS FOR MOLD SHELLS, MOLD SHELL, AND REFRIGERATION APPLIANCE COMPRISING SUCH AN ICE MAKER**

**Publication Classification**

(51) **Int. Cl.**  
*F25C 1/10* (2006.01)  
(52) **U.S. Cl.**  
CPC ..... *F25C 1/10* (2013.01)  
USPC ..... **62/340; 249/203**

(75) Inventors: **Athanasios Athanasiou**, Giengen (DE);  
**Hans-Joachim Koch**, Erlangen (DE)

(73) Assignee: **BSH BOSCH UND SIEMENS HAUSGERATE GMBH**, Munich (DE)

(57) **ABSTRACT**

An ice maker includes a frame, a mold shell having at least one chamber and capable of holding water for formation of ice cubes, and a support device which secures the mold shell in the frame and moves the mold shell between a first position for filling with water and a second position for ejecting ice cubes. The support member is able to rotate the mold shell about a rotation axis from the first position for filling with water into the second position for ejecting ice cubes. A securing device is disposed on the support device and constructed to allow manual removal of the mold shell from the ice maker and manual insertion of the mold shell into the ice maker. The securing device has at least one securing rail for pulling out and pushing in the mold shell, and extends parallel to the rotation axis.

(21) Appl. No.: **13/820,753**

(22) PCT Filed: **Aug. 24, 2011**

(86) PCT No.: **PCT/EP11/64516**

§ 371 (c)(1),  
(2), (4) Date: **Mar. 5, 2013**

(30) **Foreign Application Priority Data**

Sep. 7, 2010 (DE) ..... 10 2010 040 339.3

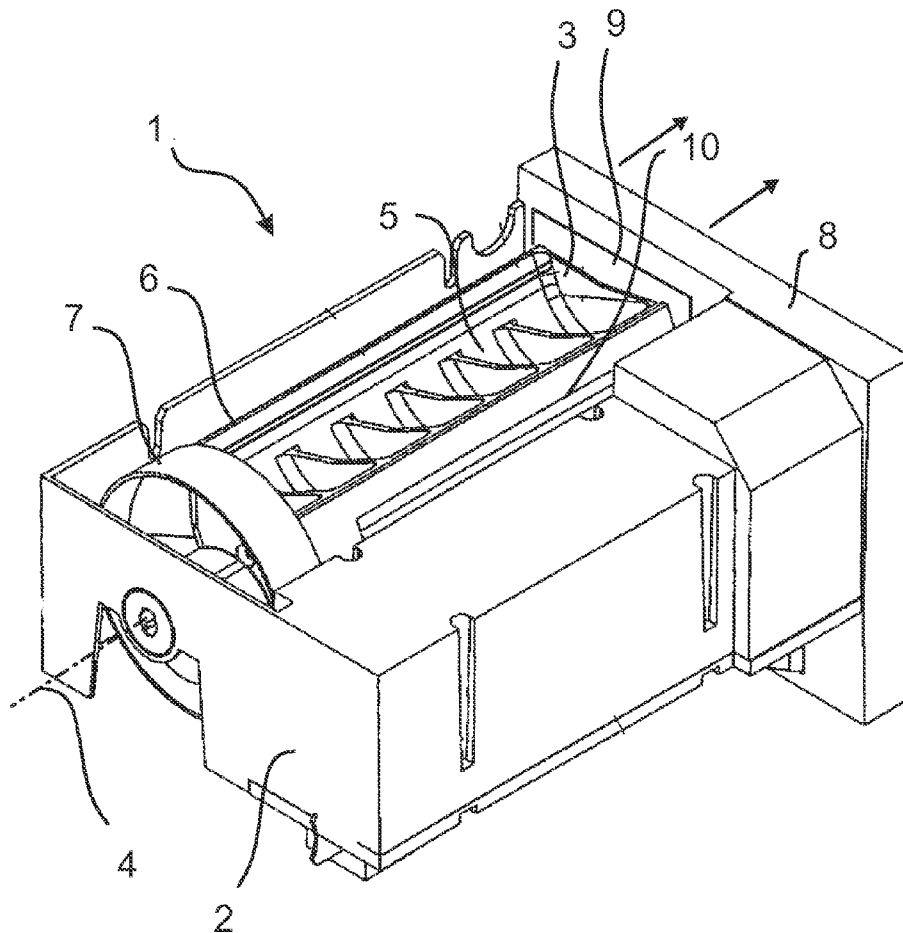

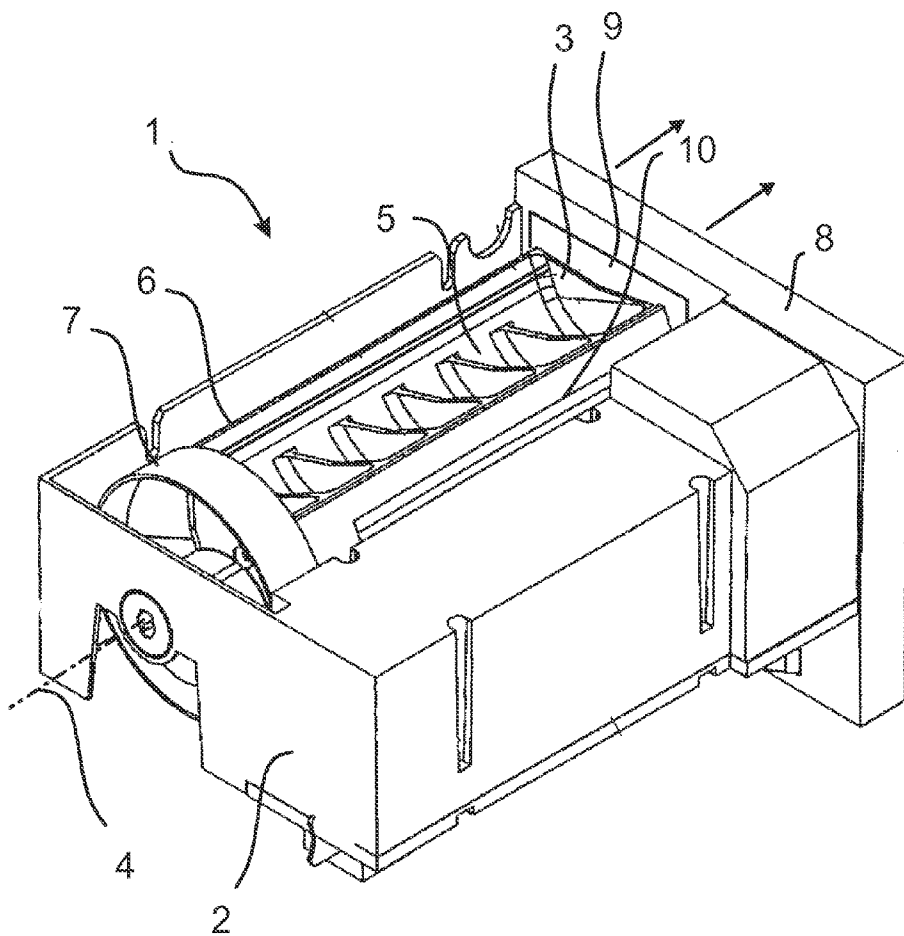

Fig. 1

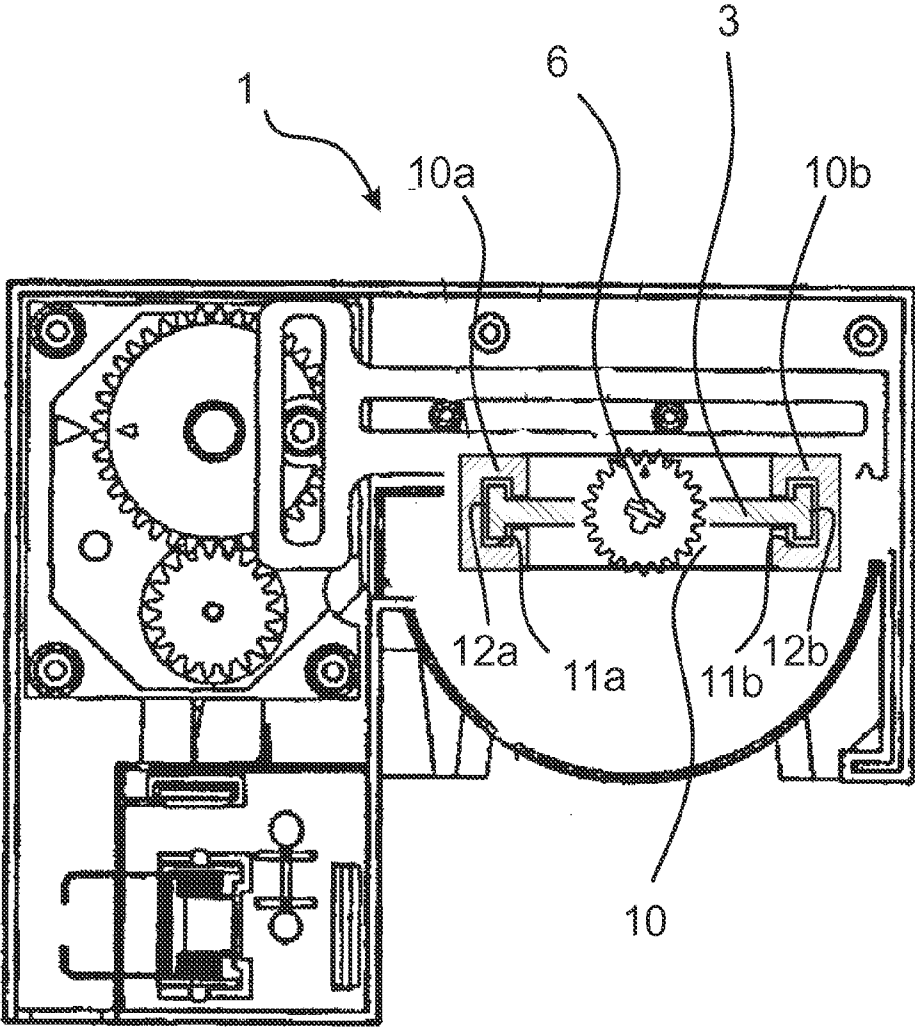
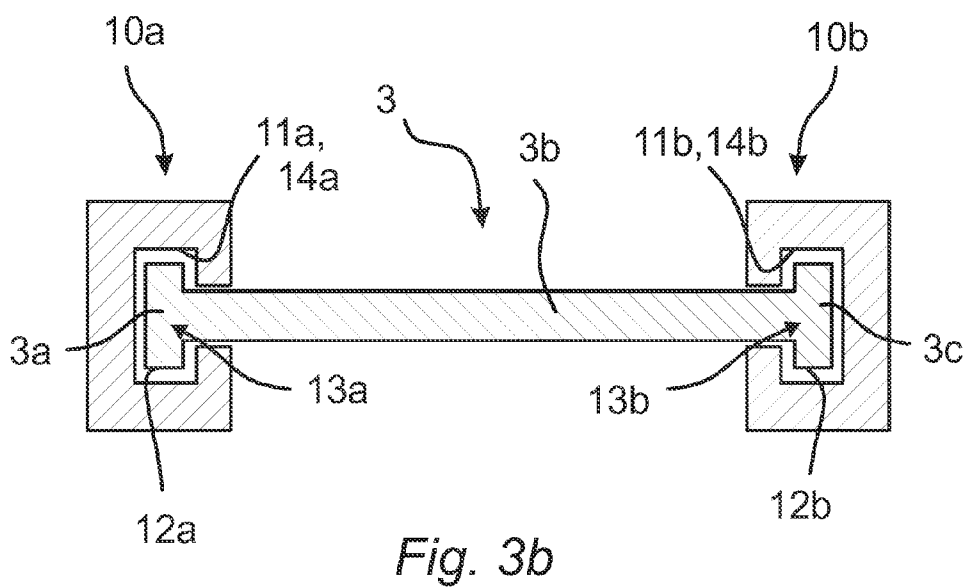
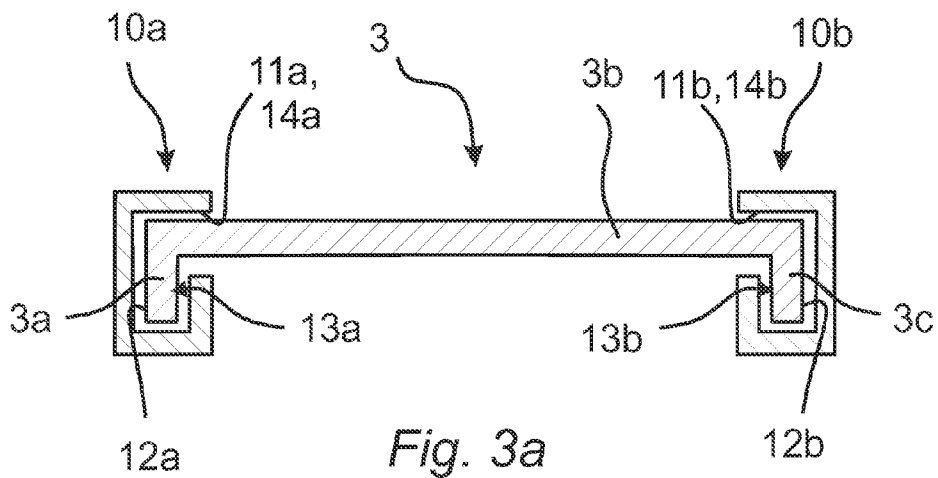
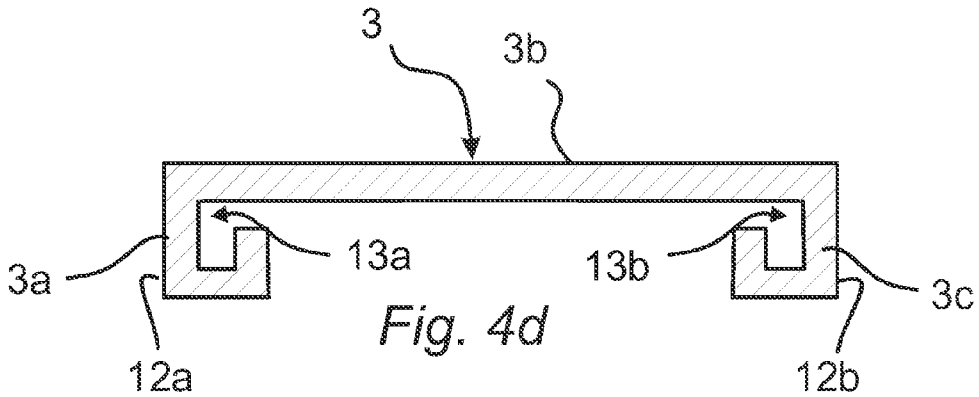
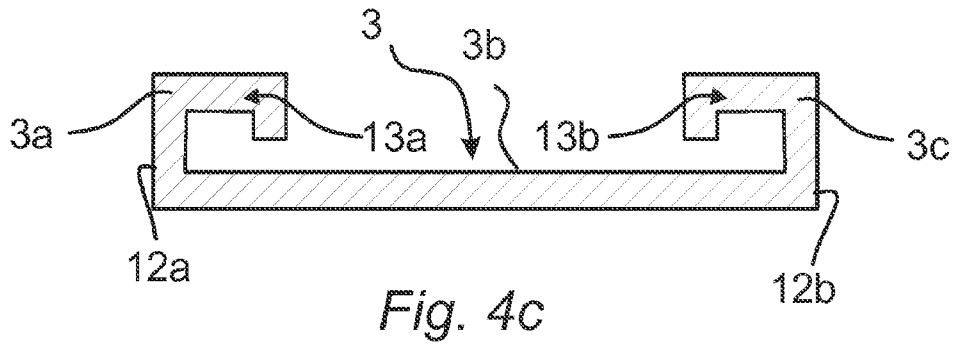
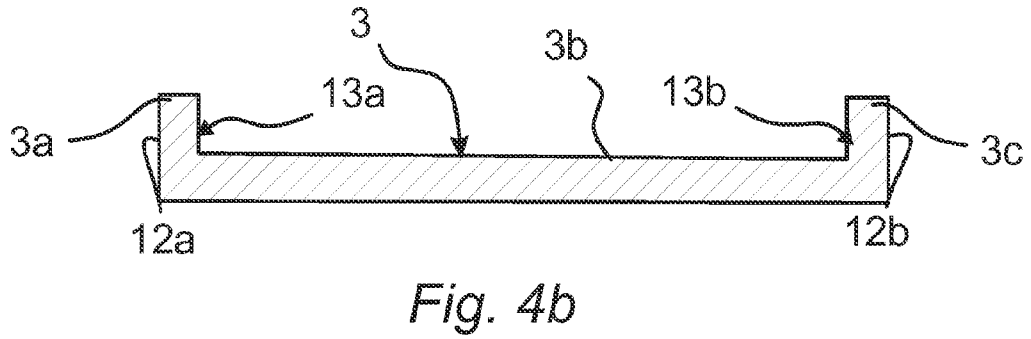
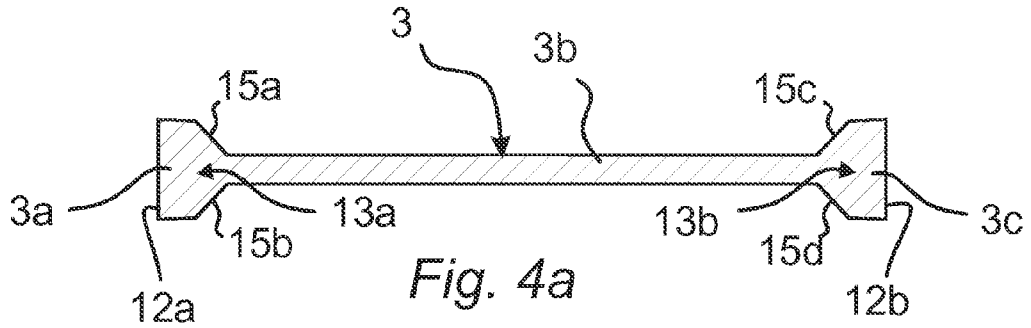

Fig. 2





**ICE MAKER COMPRISING SUPPORT  
MEANS FOR MOLD SHELLS, MOLD SHELL,  
AND REFRIGERATION APPLIANCE  
COMPRISING SUCH AN ICE MAKER**

[0001] The invention relates to an ice maker, having a frame, a mold shell that has at least one chamber and is designed to hold water such that the water can be frozen to form ice cubes, further comprising support means designed to secure the mold shell in the frame and move the mold shell between a first position for filling with water and a second position for ejecting ice cubes.

[0002] The invention also relates to an associated mold shell and a refrigeration appliance, in particular a household refrigeration appliance comprising an inventive ice maker.

[0003] WO 2006/076983 A1 describes an ice maker comprising a frame and a tray that can be pivoted about an axis in the frame, the tray having a plurality of compartments disposed in a number of rows and separated from one another by intermediate walls and being able to be pivoted between an upright position, in which the upper edges of the intermediate walls run horizontally, and an emptying position, in which the openings of the compartments face downward, the tray also being able to be pivoted into a tilted position, in which a predefined quantity of water introduced into a row in the tray partially flows over the upper edges of the intermediate walls between the compartments of the row, while the intermediate walls separate the partial quantities of the quantity of water distributed between the compartments from one another when the tray is returned to the upright position.

[0004] The object of the invention is to create an ice maker with extended usage options.

[0005] Said object is achieved by an ice maker, comprising a frame, a mold shell that has at least one chamber and is designed to hold water, such that the water can be frozen to form ice cubes, further comprising support means designed to secure the mold shell in the frame and move the mold shell between a first position for filling with water and a second position for ejecting ice cubes, with securing means being provided, which are designed to remove the mold shell from the ice maker and insert the mold shell into the ice maker.

[0006] The frame can form a mount-type housing or another base body, in which a mold shell can be secured. The chambers can form shell-like or trough-like recesses in a mold shell, in particular a plate-like mold shell. The chambers form the actual molds for producing ice cubes from water. The chambers can be embodied for example as square, in the shape of spherical segments, star-shaped or heart-shaped or moon-shaped. Also the number of chambers in each mold shell can vary. The support means are designed to secure the mold shell in the frame and to move the mold shell to and fro between the first position for filling with water and the second position for ejecting ice cubes.

[0007] The securing means are designed to allow the mold shell to be removed from the ice maker and to be inserted back into the ice maker. Removal and insertion here refer to the taking out or loading in of a mold shell out of or into the ice maker by a user, who wishes to change the mold shell within the context of the use of the ice maker, for example of a household refrigeration appliance, in particular to be able to use a mold shell with differently shaped chambers. The user therefore changes the mold shell for the purpose of extended usage options. Said user does not change the mold shell primarily for the purpose of maintaining or repairing the ice maker. The user can also replace a damaged mold shell in the

same manner. Removal and insertion here refer to the taking out or loading in of a mold shell out of or into the ice maker by a user, with no tool being required for the purpose.

[0008] The securing means can be designed for the manual removal of the mold shell from the ice maker and for the manual insertion of the mold shell into the ice maker. In one embodiment the securing means can be moved out of the ice maker or drawn into the ice maker for example by means of a motor, in particular an electric motor. However provision is made in particular for the mold shell only to be guided passively at the securing means and to be able to be removed or inserted manually, i.e. by a user of the ice maker or a refrigeration appliance having such an ice maker. The mold shell can only be guided passively at the securing means in a railed manner.

[0009] The securing means can be disposed on the support means. When the securing means are disposed on the support means, the securing means move with a movement, in particular a rotation and/or turning of the support means. This means that the mold shell inserted detachably into the securing means is rotated or turned at the same time. The support means and/or securing means can however also be designed to displace the mold shell in a linear manner. The mold shell can also perform a superimposed translation and rotation movement.

[0010] The securing means can have at least one securing rail for pulling out and pushing in the mold shell. The securing rails can be designed to guide or support the mold shell along a linear movement, i.e. a translational movement. In other words the mold shell can be inserted into the ice maker or removed from the ice maker, for example in the manner of an electronic plug-in card, a chip card or a compact music disk (CD). The mold shell can be inserted into the ice maker from the outside by way of an opening in a housing wall.

[0011] The support means can be designed to rotate the mold shell about a rotation axis from the first position for filling with water into the second position for ejecting ice cubes, with the at least one securing rail being able to extend parallel to the rotation axis. The mold shell can therefore be rotated or pivoted from the first position for filling with water into the second position for ejecting ice cubes. In the second position for ejecting ice cubes the mold shell can be rotated through 180 degrees in relation to the illustrated position, in other words turned on its head, so that the chambers face downward and the ice cubes can drop out. The ice maker can be designed so that the mold shell can only be removed from the ice maker or inserted therein in the first position, in which it is provided for filling with water. Alternatively the ice maker can be designed so that the mold shell can only be removed from the ice maker or inserted therein in the second position, in which it is provided for ejecting ice cubes.

[0012] Two securing rails can in particular be disposed at a distance from one another and running parallel to one another, so that the mold shell is secured between the two securing rails. This allows the mold shell to be secured by the two securing rails at two opposing edges.

[0013] At least one securing rail can have an undercut groove running in the longitudinal extension of the securing rail, in which groove at least one projection of the mold shell engages. The undercut groove and the at least one projection of the mold shell can have corresponding cross sections. The undercut groove and the at least one projection of the mold shell can have corresponding cross sections with an L-shaped, T-shaped, C-shaped or polygonal contour segment.

[0014] In all the inventive embodiments the ice maker can have a housing wall with an opening, which is designed for the removal and insertion, in particular the pulling out and pushing in of the mold shell from the ice maker, in particular being matched to a contour of the mold shell.

[0015] The invention also relates to a refrigeration appliance, in particular a household refrigeration appliance, comprising an ice maker according to one of the described embodiments.

[0016] The invention also relates to a mold shell comprising at least one chamber, which is designed to hold water such that the water can be frozen to form ice cubes, and comprising at least one projection, which is formed in particular by an L-shaped, T-shaped, C-shaped or polygonal lateral segment of the mold shell, the mold shell being designed to be able to be pushed into a corresponding groove in a securing rail of an ice maker.

[0017] The ice maker here can be designed in particular according to one of the described embodiments.

[0018] The mold shell can have a projection extending longitudinally in the manner of a rail on each of two opposing lateral segments.

[0019] To summarize and in other words, the invention therefore provides inter alia an ice maker, with which it is possible to change the mold shell. This allows different mold shells to be inserted as desired into the ice maker, with the result that ice cubes of different configurations, in particular of different sizes and/or shapes, can be produced in the ice maker. It is thus possible to produce for example large, medium-sized or small ice cubes. The ice cubes can also have any selected geometric shape. The inventive mold shells can be changed manually in particular by a user. The mold shells can in particular be changed without tools. The user can make a selection from a plurality of different mold shells with differently configured chambers. As a specific secondary effect the user also has the option of standing the mold shells not inserted into the ice maker in a separate freezer compartment of a refrigeration appliance, in order to be able to produce ice cubes statically just due to the cold inside the freezer compartment without an ice maker. The invention allows a user of the ice maker to configure ice cubes to his/her personal taste, for drinks such as cocktails for example.

[0020] Further features and advantages of the inventive ice maker will emerge from the description of different exemplary embodiments which follows, with reference to the accompanying figures. Specific features of these exemplary embodiments can represent general features of the invention. In the figures:

[0021] FIG. 1 shows a perspective view of an ice maker comprising an inventive securing means for interchangeable mold shells;

[0022] FIG. 2 shows a cross-sectional view of the ice maker according to FIG. 1 with the inventive securing means for interchangeable mold shells;

[0023] FIG. 3a shows a cross-sectional view of a first embodiment of the inventive securing means with a first embodiment of the mold shell;

[0024] FIG. 3b shows a cross-sectional view of a second embodiment of the inventive securing means with a second embodiment of the mold shell;

[0025] FIG. 4a shows a cross-sectional view of a third embodiment of the mold shell;

[0026] FIG. 4b shows a cross-sectional view of a fourth embodiment of the mold shell;

[0027] FIG. 4c shows a cross-sectional view of a fifth embodiment of the mold shell;

[0028] FIG. 4d shows a cross-sectional view of a sixth embodiment of the mold shell.

[0029] FIG. 1 shows an ice maker 1 comprising a frame 2. The frame 2 forms a mount-type housing. A mold shell 3 is supported in a movable manner in the frame 2. In the illustrated exemplary embodiment the mold shell 3 is supported in the frame 2 in such a manner that it can be rotated or pivoted about a rotation axis 4. In the position illustrated in FIG. 1 the mold shell 3 is in a first position for filling with water. To this end the mold shell 3 has at least one chamber 5, in the illustrated example several or six chambers 5. An ice cube can be produced in each chamber 5. The mold shell 3 is secured in a support means 6. The support means 6 is connected to a flange 7, which is supported in the frame 2 in such a manner that it can be rotated or pivoted about the longitudinal axis 4. When the support means 6 is rotated or pivoted by driving the flange 7, the mold shell 3 rotates or pivots with it. This allows the mold shell 3 to be rotated or pivoted from the illustrated first position for filling with water to a second position for ejecting ice cubes. In the second position for ejecting ice cubes the mold shell 3 can be rotated through 180 degrees in relation to the illustrated position, in other words turned on its head, so that the chambers 5 face downward and the ice cubes can drop out.

[0030] The ice maker 1 has a front housing wall 8, shown in FIG. 1 on a rear plane. The housing wall 8 is connected to the frame 2 or forms part of the frame 2. The housing wall 8 has an opening 9. The mold shell 3 can be pulled out of the ice maker 1 and pushed back in again in the direction of the arrow by way of the opening 9. To this end securing means 10 are provided, which are connected to the support means 6. The securing means 10 are designed to allow the mold shell 3 to be removed from the ice maker 1 and to be inserted back into the ice maker 1. Removal and insertion here refer to the taking out or loading in of a mold shell 3 out of or into the ice maker 1 by a user, who wishes to change the mold shell 3 within the context of the use of the ice maker 1, for example of a household refrigeration appliance, in particular to be able to use a mold shell 3 with differently shaped chambers 5. The user therefore changes the mold shell 3 for the purpose of extended usage options. Said user does not change the mold shell 3 primarily for the purpose of maintaining or repairing the ice maker. The user can also replace a damaged mold shell 3 in the same manner. Removal and insertion here refer to the taking out or loading in of a mold shell 3 out of or into the ice maker 1 by a user, with no tool being required for the purpose.

[0031] FIG. 2 shows a cross-sectional view of the ice maker 1. The securing means 10 is disposed on or fastened to the support means 6. In the illustrated exemplary embodiment in FIG. 2 the securing means 10 has two opposing securing rails 10a, 10b. The securing rails 10a, 10b have inner contours 11a, 11b, which enclose outer contours 12a, 12b of the mold shell 3. When the support means 6 rotates, the securing rails 10a, 10b of the securing means 10 also rotate and carry with them the mold shell 3, the outer contours 12a, 12b of which are enclosed by the inner contours 11a, 11b of the securing rails 10a, 10b. The mold shell 3 can be pulled out or pushed in by a user in a direction perpendicular to the plane of the drawing in FIG. 2.

[0032] FIGS. 3a and 3b show two exemplary variants of contour configurations for the outer contours 12a, 12b of the mold shell 3 and the inner contours 11a, 11b of the securing rails 10a, 10b.

[0033] FIGS. 4a to 4d show further exemplary variants of contour configurations for the outer contours 12a, 12b of the mold shell 3. These can be assigned inner contours 11a, 11b of securing rails 10a, 10b, which are configured in a correspondingly congruent manner.

[0034] FIG. 3a shows a first embodiment of the mold shell 3. The mold shell 3 has a middle segment 3b, which supports the chambers 5. On two opposing lateral faces of the mold shell 3 the middle segment 3b is delimited by a first lateral segment 3a shown on the left in FIG. 3a and a second lateral segment 3c shown on the right in FIG. 3a. The first lateral segment 3a and the second lateral segment 3c are formed by arms, which extend at a right angle away from the plane of the middle segment 3b of the mold shell 3. The first lateral segment 3a and the second lateral segment 3c have right-angled outer contours 12a, 11b. The two securing rails 10a, 10b have corresponding or congruent inner contours 11a, 11b, i.e. right-angled contour cross sections, corresponding to the outer contours 12a, 12b of the mold shell 3. The outer contours 12a, 12b of the lateral segments 3a and 3c form projections 13a, 13b with L-shaped cross-sectional contours. The inner contours 11a, 11b form grooves 14a, 14b in the securing rails 10a, 10b, in which the projections 13a, 13b of the mold shell 3 engage.

[0035] FIG. 3b shows a second embodiment of the mold shell 3. The mold shell 3 has a middle segment 3b, which supports the chambers 5. On two opposing lateral faces of the mold shell 3 the middle segment 3b is delimited by a first lateral segment 3a shown on the left in FIG. 3a and a second lateral segment 3c shown on the right in FIG. 3a. The first lateral segment 3a and the second lateral segment 3c project down and up at a right angle from the plane of the middle segment 3b of the mold shell 3. The first lateral segment 3a and the second lateral segment 3c have right-angled outer contours 12a, 11b. The two securing rails 10a, 10b have corresponding or congruent inner contours 11a, 11b, i.e. right-angled contour cross sections, corresponding to the outer contours 12a, 12b of the mold shell 3. The outer contours 12a, 12b of the lateral segments 3a and 3c form projections 13a, 13b with T-shaped cross-sectional contours. The inner contours 11a, 11b form the grooves 14a, 14b in the securing rails 10a, 10b, in which the projections 13a, 13b of the mold shell 3 engage.

[0036] FIG. 4a shows a third embodiment of the mold shell 3. The mold shell 3 has a middle segment 3b, which supports the chambers 5. On two opposing lateral faces of the mold shell 3 the middle segment 3b is delimited by a first lateral segment 3a shown on the left in FIG. 3a and a second lateral segment 3c shown on the right in FIG. 3a. The first lateral segment 3a and the second lateral segment 3c have outer contours 12a, 12b, which in contrast to a T-shaped cross-sectional contour have transition inclines 15a, 15b, 15c, 15d, which extend in particular at a 45 degree angle outward from the plane of the middle segment 3b, widening as they do so. The two securing rails 10a, 10b can have corresponding or congruent inner contours 11a, 11b corresponding to the outer contours 12a, 12b of the mold shell 3.

[0037] FIG. 4b shows a fourth embodiment of the mold shell 3. The mold shell 3 has a middle segment 3b, which supports the chambers 5. On two opposing lateral faces of the

mold shell 3 the middle segment 3b is delimited by a first lateral segment 3a shown on the left in FIG. 3a and a second lateral segment 3c shown on the right in FIG. 3a. The first lateral segment 3a and the second lateral segment 3c have outer contours 12a, 12b, which extend with L-shaped cross-sectional contours upward at a right angle from the plane of the middle segment 3b. The two securing rails 10a, 10b can have corresponding or congruent inner contours 11a, 11b corresponding to the outer contours 12a, 12b of the mold shell 3.

[0038] FIG. 4c shows a fifth embodiment of the mold shell 3. The mold shell 3 has a middle segment 3b, which supports the chambers 5. On two opposing lateral faces of the mold shell 3 the middle segment 3b is delimited by a first lateral segment 3a shown on the left in FIG. 3a and a second lateral segment 3c shown on the right in FIG. 3a. The first lateral segment 3a and the second lateral segment 3c have outer contours 12a, 12b, which enclose the outside of the securing rails 10a, 10b completely on three sides, so that the mold shell 3 does not engage in grooves in the securing rails 10a, 10b but the outer contours 12a, 12b of the mold shell 3 engage around projecting peripheral segments of the securing rails 10a, 10b. The outer contours 12a, 12b of the mold shell 3 according to this fifth embodiment thus form grooves in the mold shell 3, in which projections of the securing rails 10a, 10b engage. The two securing rails 10a, 10b can have corresponding or congruent inner contours 11a, 11b corresponding to the outer contours 12a, 12b of the mold shell 3. The projections of the securing rails 10a, 10b here are enclosed from bottom to top by the outer contours 12a, 12b of the mold shell 3.

[0039] FIG. 4d shows a sixth embodiment of the mold shell 3. The mold shell 3 has a middle segment 3b, which supports the chambers 5. On two opposing lateral faces of the mold shell 3 the middle segment 3b is delimited by a first lateral segment 3a shown on the left in FIG. 3a and a second lateral segment 3c shown on the right in FIG. 3a. The first lateral segment 3a and the second lateral segment 3c have outer contours 12a, 12b, which enclose the outside of the securing rails 10a, 10b completely on three sides, so that the mold shell 3 does not engage in grooves in the securing rails 10a, 10b but the outer contours 12a, 12b of the mold shell 3 engage around projecting peripheral segments of the securing rails 10a, 10b. The outer contours 12a, 12b of the mold shell 3 according to this sixth embodiment thus correspond to those of the fifth embodiment and also form grooves in the mold shell 3, in which projections of the securing rails 10a, 10b engage, with the outer contours 12a, 12b enclosing the securing rails 10a, 10b from top to bottom not from bottom to top. The two securing rails 10a, 10b can have corresponding or congruent inner contours 11a, 11b corresponding to the outer contours 12a, 12b of the mold shell 3.

1-13. (canceled)

14. An ice maker, comprising:

a frame,

a mold shell having at least one chamber and capable of holding water for formation of ice cubes,

a support device constructed to secure the mold shell in the frame and to move the mold shell between a first position for filling with water and a second position for ejecting ice cubes, said support member being constructed to rotate the mold shell about a rotation axis from the first position for filling with water into the second position for ejecting ice cubes, and

a securing device disposed on the support device and constructed to allow manual removal of the mold shell from the ice maker and manual insertion of the mold shell into the ice maker, said securing device having at least one securing rail for pulling out and pushing in the mold shell, said securing rail extending parallel to the rotation axis.

**15.** The ice maker of claim **14**, wherein the securing device has two of said securing rail disposed in parallel relationship at a distance from one another such that the mold shell is secured between the two securing rails.

**16.** The ice maker of claim **14**, wherein the at least one securing rail has an undercut groove running in a longitudinal extension of the securing rail for engagement of at least one projection of the mold shell.

**17.** The ice maker of claim **16**, wherein the undercut groove and the at least one projection of the mold shell have corresponding cross sections.

**18.** The ice maker of claim **17**, wherein the undercut groove and the at least one projection of the mold shell have corresponding cross sections with an L-shaped, T-shaped, C-shaped or polygonal contour segment.

**19.** The ice maker of claim **14**, further comprising a housing wall having an opening configured to allow insertion and removal of the mold shell into and from the ice maker.

**20.** The ice maker of claim **19**, wherein the opening has a contour which matches a contour of the mold shell.

**21.** A refrigeration appliance, having an ice maker which includes a frame, a mold shell having at least one chamber and capable of holding water for formation of ice cubes, a support device constructed to secure the mold shell in the frame and to move the mold shell between a first position for filling with water and a second position for ejecting ice cubes, said support member being constructed to rotate the mold shell about a rotation axis from the first position for filling with water into the second position for ejecting ice cubes, and a securing device disposed on the support device and constructed to allow manual removal the mold shell from the ice maker and manual insertion of the mold shell into the ice maker, said

securing device having at least one securing rail for pulling out and pushing in the mold shell, said securing rail extending parallel to the rotation axis.

**22.** The refrigeration appliance of claim **21**, constructed in the form of a household refrigeration appliance.

**23.** The refrigeration appliance of claim **21**, wherein the securing device has two of said securing rail disposed in parallel relationship at a distance from one another such that the mold shell is secured between the two securing rails.

**24.** The refrigeration appliance of claim **21**, wherein the at least one securing rail has an undercut groove running in a longitudinal extension of the securing rail for engagement of at least one projection of the mold shell.

**25.** The refrigeration appliance of claim **24**, wherein the undercut groove and the at least one projection of the mold shell have corresponding cross sections.

**26.** The refrigeration appliance of claim **25**, wherein the undercut groove and the at least one projection of the mold shell have corresponding cross sections with an L-shaped, T-shaped, C-shaped or polygonal contour segment.

**27.** The refrigeration appliance of claim **21**, wherein the ice maker includes a housing wall having an opening configured to allow insertion and removal of the mold shell into and from the ice maker.

**28.** The refrigeration appliance of claim **27**, wherein the opening has a contour which matches a contour of the mold shell.

**29.** A mold shell, comprising at least one chamber capable of holding water for formation of ice cubes, and a segment member supporting the chamber and having two opposing lateral segments configured to form projections extending longitudinally in a manner of a rail for disengagement from and engagement into corresponding grooves in a securing rail of an ice maker.

**30.** The mold shell of claim **29**, wherein the lateral segments have each an L-shaped, T-shaped, C-shaped or polygonal configuration.

\* \* \* \* \*