

⑫ **EUROPEAN PATENT APPLICATION**

⑰ Application number: 89301400.1

⑮ Int. Cl. 4: **B61D 27/00**

⑱ Date of filing: 15.02.89

⑳ Priority: 05.08.88 JP 194411/88

㉓ Date of publication of application:  
07.02.90 Bulletin 90/06

㉔ Designated Contracting States:  
**DE FR GB IT**

㉖ Applicant: **HITACHI, LTD.**  
**6, Kanda Surugadai 4-chome**  
**Chiyoda-ku Tokyo 101(JP)**

㉗ Inventor: **Kimura, Kenji**  
**Koyodai 177-12, Nishitoyoi**  
**Kudamatsu-shi Yamaguchi-ken(JP)**  
Inventor: **Matsuda, Toshiharu**  
**4-6-19, Hataoka**  
**Kudamatsu-shi Yamaguchi-ken(JP)**  
Inventor: **Matsumoto, Masakazu**  
**Suemitsu Apartment 5-47 1598-35, Nishitoyoi**  
**Kudamatsu-shi Yamaguchi-ken(JP)**  
Inventor: **Hanada, Shozo**  
**21-15, Usuidai**  
**Sakura-shi Chiba-ken(JP)**  
Inventor: **Sakamoto, Masayoshi**  
**1805-4, Shimoinayoshi Chiyodamura**  
**Niihari-gun Ibaraki-ken(JP)**

㉘ Representative: **Calderbank, Thomas Roger et al**  
**MEWBURN ELLIS 2 Cursitor Street**  
**London EC4A 1BQ(GB)**

㉙ **Ventilating equipment for vehicle.**

㉚ The present invention relates to a ventilating equipment for a vehicle. In the vehicles in recent years, the space allowed to dispose equipments for the vehicle is subjected to a tendency of being limited since the comfort of the vehicle has been improved. Therefore, the size of ventilating equipments has been required to be reduced. The present invention is characterized by that a supply-air equipment (20) and an exhaust-air equipment (30) are connected to one driving device (11) for the purpose of reducing the overall size of the equipment and thereby minimizing the space in which this equipment is located. Furthermore, the driving device of the equipment structured as described above is arranged to be effectively cooled by utilizing air to be supplied or air to be exhausted.

**EP 0 353 832 A1**

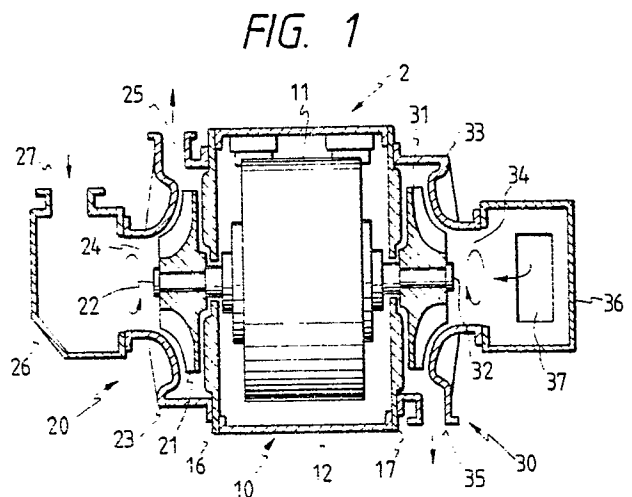

## VENTILATING EQUIPMENT FOR VEHICLE

The present invention relates to a ventilating equipment for a vehicle, and, more particularly, to a ventilating equipment for a vehicle preferably used in the vehicle which is caused to be subjected to a sudden ambient air pressure change when it runs, for example, the vehicles which runs through tunnels at a high speed.

A vehicle which runs through a tunnel at a high speed is subjected to a sudden ambient air pressure change in particular when vehicles pass each other. Therefore, the ambient air pressure can be transmitted to the vehicle inside, making the passengers feel uncomfortable, for example, a phenomenon occurs that the passengers have an earache. Conventionally, such vehicles employ, as the supply-air equipment and exhaust-air equipment of the ventilating equipment which communicates the outside and inside of the car body, the supply-air equipment having an air quantity which cannot be changed by the change of the ambient air pressure. As a result, the transmission of the pressure change to the vehicle inside is restricted, and the passengers can be prevented from the uncomfortable pressure change.

As an equipment of the above-described type, for example, an equipment disclosed in U.S.P. 3, 563, 155 is known. In this equipment, a supply-air equipment is provided on the roof of the car body, while, the under floor of the car body is provided with an exhaust-air equipment. The supply-air equipment and the exhaust-air equipment are arranged to be a supply-air equipment represented by a high pressure supply-air equipment displaying small air quantity change with respect to a static pressure change, that is, the change of the ambient air pressure change, and as well exhibiting high static pressure characteristics.

As a related equipment to the above-described type equipment, an equipment disclosed in Japanese Patent Laid-Open No. 62-227851 is known, in which an supply-air equipment is provided on the roof of the vehicle, while, an exhaust-air equipment is provided in the under floor of the vehicle. In addition, a air flow passage adjustable means is provided in the vicinity of the inlet port of the supply-air equipment and the outlet port of the exhaust-air equipment. This pressure absorbing mechanism acts to restrict the pressure change on the vehicle inside by preventing the inverse flow of air even if the atmospheric pressure is suddenly changed.

In addition, an equipment disclosed in Japanese Patent Publication No. 58-9022 and that disclosed in Japanese Patent Laid-Open No. 62-234777 are known.

The equipment disclosed in Japanese Patent Publication No. 58-9022 is arranged in such a manner that an supply-air equipment is provided on the roof of the vehicle, while, an exhaust-air equipment is provided in the under floor of the vehicle. At least one of the supply-air equipment and the exhaust-air equipment is adjusted in their air quantity in accordance with the temperature difference between the vehicle inside and the vehicle outside. As a result, the pressure change in the vehicle inside caused from the difference in the temperature between the vehicle inside and outside can be prevented.

The equipment disclosed in Japanese Patent Laid-Open No. 62-234777 is arranged in such a manner that a ventilating unit is provided on the roof of the car body. This ventilating unit is arranged in such a manner that a ventilating blower is respectively provided at two ends of the motor shaft of the electric motor and the ventilating fan thereof and the air supply duct thereof are respectively connected by a duct. In addition, an electric heater is provided in the air supply duct. Air discharged from the ventilating blower is heated by this heater as to be sent to the vehicle inside. Air in the vehicle is taken by the ventilating blower as to be again discharged through the ventilating blower.

In the above-described conventional equipments, there are equipments arranged in such a manner that two ventilating blowers (supply-air blowers) are made to form a unit to serve as the ventilating unit, and to be secured to one electric motor. However, in a case wherein individual type equipments are provided, that is, in a case where the equipment is constituted by a supply-air equipment and an exhaust-air equipment, these supply-air equipment and exhaust-air equipment are individually provided as to be respectively disposed on the roof and the under floor of the vehicle. Therefore, the vehicle needs to be provided with the spaces for these equipments respectively. Recently, the vehicles are needed to enlarge the passenger room space and to improve the equipments such as the air conditioner and so forth in accordance with the trend of arisen necessity of improving the comfortability. As a result, the spaces allowed to position the equipments are restricted in the vehicles. Therefore, the compact supply-air equipment and exhaust-air equipment are needed to be realized.

An object of the present invention is to provide a ventilating equipment for a vehicle whose size can be minimized and thereby the space for it can be reduced.

A second object of the present invention is to provide a ventilating equipment for a vehicle whose size can be minimized and thereby the space for it can be reduced and capable of effectively cooling the driving motor for the ventilating equipment.

The above-described first object can be realized by connecting a supply-air equipment and an exhaust-air equipment to a driving device.

The above-described second object can be realized by connecting a supply air equipment and an exhaust-air equipment to a driving device and by cooling the driving device by air in the vehicle to be exhausted to the outside the vehicle.

In addition, the above-described second object can be realized by connecting a supply-air equipment and an exhaust-air equipment to a driving device and by cooling the driving device by air to be supplied to the vehicle inside from outside the vehicle.

In the drawings:

Fig. 1 is a vertical cross-sectional view of a ventilating equipment for a vehicle according to the present invention;

Fig. 2 is a plan view of Fig. 1;

Fig. 3 is a front view taken along line A-A shown in Fig. 2;

Fig. 4 is a front view taken along line B-B shown in Fig. 2;

Fig. 5 is a plan view illustrating the position at which the ventilating equipment for a vehicle shown in Fig. 1 is disposed;

Fig. 6 is a front view of Fig. 5;

Fig. 7 is a plan view illustrating a ventilating equipment for a vehicle according a second embodiment of the present invention;

Fig. 8 is a front view of Fig. 7;

Fig. 9 is a vertical cross-sectional view illustrating a ventilating equipment for a vehicle according to a third embodiment of the present invention;

Fig. 10 is a side-elevational view taken along line C-C in Fig. 9;

Fig. 11 is a vertical cross-sectional view illustrating a ventilating equipment for a vehicle according to a fourth embodiment of the present invention;

Fig. 12 is a plan view of Fig. 11;

Fig. 13 is a plan view illustrating the driving means and examples of the combination of the blowers in the ventilating equipment according to the present invention.

An embodiment of the present invention will now be described with reference to Fig. 1 to 6.

As shown in Fig. 1, a motor 11 is disposed in a case 12 having two opening ends. This case 12 is provided with a mount base 15. The motor 11 is, at its two ends, provided with driving shafts. Partition walls 16 and 17 each having an opening portion in the central portion thereof are secured to the two

ends of the case 12. The driving shafts of the motor 11 are projected over the opening portions at the central portions of the partition walls 16 and 17. The central portions of the partition walls 16 and 17 and the driving shafts of the motor 17 are sealed up for the purpose of securing airtightness. A driving device 10 comprises the motor 11, the case 12, and the partition walls 16 and 17.

A blower 21 is mounted on an end of the driving shaft of the motor 11. A stopper plate 22 is fastened to the driving shaft. This stopper plate 22 acts to stop the blower 21 from being separated from the driving shaft. A case 23 is fastened to the partition wall 16 as to cover the blower 21. This case 23 performs a role of a guide plate when air is supplied by the rotation of the blower 21. An inlet port 24 is provided in the central portion of the case 23 at the position corresponding to the blower 21. An outlet port 25 is provided in the outer portion of the case 23. The outlet port 25 is provided in the upper portion of the case 23. The inlet port 24 in the case 23 is provided with a duct 26. An opening 27 is formed in the upper portion of the duct 26. A supply-air equipment 20 is thus constituted by the partition wall 16, blower 21 and the case 23.

A blower 31 is mounted on the other end of driving shaft of the motor 11. A stopper plate 32 is fastened to this driving shaft. This stopper plate 32 acts to stop separation of the blower 31 from the driving shaft. This stopper plate 32 acts to stop the blower 31 from being separated from the driving shaft. A case 33 is fastened to the partition wall 17 as to cover the blower 31. This case 33 performs a role of a guide plate when air is supplied by the rotation of the blower 31. An inlet port 34 is provided in the central portion of the case 33 at the position corresponding to the blower 31. An outlet port 35 is provided in the case 33. The outlet port 35 is provided in the lower portion of the case 33. A duct 36 is secured to the inlet port 34 in the case 33. As shown in Fig. 2, an opening 37 is provided in the duct 36. An exhaust-air equipment 30 is constituted by the partition wall 17, the blower 31 and the case 33.

The thus-formed supply-air equipment 20 and the exhaust-air equipment 30 are arranged to be a high pressure blower having a pressure characteristics greater than the ambient air pressure generated when the vehicle runs through a tunnel. Therefore, change in the air quantity can be reduced with respect to the change in the ambient air pressure and a high static pressure characteristics can be realized.

The side surfaces of the case 12 are, as shown in Fig. 2, provided with an inlet port 13 or an exhaust 14. As shown in Figs. 2 and 3, a duct 41 is provided in the portion in the vicinity of the inlet

port 13 in the case 12. This duct 41 is provided with openings 42 and 43 at the two ends thereof. The opening 43 in the duct 41 is secured to the inlet port 13 in the case 12. A duct 44 is, as shown in Figs. 2 and 4, fastened to the portion in the vicinity of the outlet 14 in the case 12. This duct 44 is provided with opening 45 and 46 at two ends thereof. This opening 45 in the duct 44 is fastened to the outlet port 14 in the case 12. An opening 46 in the duct 44 is fastened to the opening 37 in the duct 36.

An ventilating equipment 2 is constituted, in this case, by the driving device 10, the supply-air equipment 20, the exhaust-air equipment 30, and ducts 26, 36, 41 and 44.

The thus-formed ventilating equipment 2 is, as shown in Figs. 5 and 6, positioned by, for example, a base 15 in the lower surface of the frame portion in the bottom portion of the vehicle 1 for the purpose of being fastened and located. In the under floor of the vehicle, in this case, in the space between the floor and the under frame, room ventilating ducts 54 and 55, and exhaust-air ducts 52 and 53 and supply-air duct 51 are disposed in the longitudinal direction of the vehicle 1. A supply-air duct 50 is disposed under the floor of the vehicle 1. The spaces formed in this body structure are used as ducts 56 to 59. The lower surface of the body structure forming the ducts 57 to 59 is provided with an air conditioner 3.

An end of the supply-air duct 50 disposed in the under floor structured as described above starts at the end portion of the vehicle 1. Supply-air duct 50 provided on the end is opened downwards. Another end of the supply-air duct 50 is bent downwards and is provided with an opening 60. The opening 60 in the supply-air duct 50 and the opening 27 in the duct 26 of the ventilating equipment 2 are connected to each other. An end of the supply-air duct 51 is bent downwards, and is provided with an opening 61. An opening 61 of the supply-air duct 51 and the outlet port 25 in the case 23 of the ventilating equipment 2 are connected to each other. The supply-air duct 51 and the duct 58 are connected to each other by an opening 62. A duct 58 and the air conditioner 3 are connected to each other by an opening 65. The duct 58, exhaust-air ducts 52 and 53 are connected to each other by opening 63 and 64. The exhaust-air ducts 52, 53, and duct 56 are connected to each other by openings 72 and 73. The duct 56 is provided with an opening 74. The opening 74 of the duct 56 and an opening 42 of the duct 41 of the ventilating equipment 2 are connected to each other. The air conditioner 3, ducts 57 and 59 are connected to each other by openings 66 and 67. The duct 57, conditioned air ducts 54 and 55 are connected to each other by openings 68 and 69.

The duct 59, conditioned air ducts 54 and 55 are connected to each other by openings 70 and 71.

In the ventilating equipment constituted as described above, an operation of the same is as follows: that is, the motor 11 shown in Fig. 1 is first rotated. As a result, the blowers 21 and 31 are rotated. By virtue of the rotation of the blower 21, air is taken in through the inlet port 24, this air being then compressed and raised in the pressure thereof as to be discharged through the outlet port 25. As a result of rotation of the blower 31, air is taken in through the inlet port 34, this air being then compressed and raised in the pressure thereof as to be discharged through the outlet port 35. In this state, air to be taken in through the inlet port 34 is introduced through the opening 42 in the duct 41, and reaches the inlet port 34 via the duct 41, case 12, duct 44 and the duct 36 in this sequential order.

As a result of the above-described operation of the ventilating equipment 2, ambient air, as shown in Figs. 5 and 6, taken in the supply-air duct 50 through the end of the vehicle 1. Air introduced into the supply-air duct 50 is then introduced into the duct 26 via the openings 60 and 27. The ambient air in the duct 26 is taken into the supply-air duct 51 by the supply-air equipment 20 via the opening 61, ambient air taken into the supply-air duct 51 is introduced into the air conditioner 3 through the openings 62 and 65. In a cooling mode, air cooled by the air conditioner 3, while air heated by the same in a heating mode, that is, air whose temperature has been conditioned, is introduced into the ducts 57 and 59 via the openings 66 and 67. Air introduced into the ducts 57 and 59 is then introduced into the conditioned air ducts 54 and 55 via the openings 68, 70, 69 and 71. Air introduced into the conditioned air ducts 54 and 55 is supplied to the room inside of the vehicle 1.

Air in the room of the vehicle 1 is taken in the exhaust-air ducts 52 and 53. Air which has been introduced into the exhaust-air ducts 52 and 53, that is, a part or exhaust, is introduced into the duct 58 via the openings 63 and 64. Exhaust air introduced into the duct 58 is introduced again into the air conditioner 3 via the opening 65 together with ambient air which has been sent by the ventilating equipment 2. A residue of exhaust introduced into the exhaust-air ducts 52 and 53 is introduced into the duct 56 via the openings 72 and 73. Exhaust air introduced into the duct 56 is introduced into the duct 44 of the ventilating equipment 2 via the opening 74. Exhaust air introduced into the duct 44 is exhausted outside the vehicle 1 through the outlet port 35 via the case 12, ducts 44 and 36, and the exhaust-air equipment 30.

The ventilation for the vehicle room as described above is characterized as follows: first, the

blower 21 is surrounded by the partition wall 16 and the case 23 so that the air passage space for the supply-air equipment 20 is individually separated. As a result, this space is separated from the air passage for the driving device 10. As a result, fresh air on the vehicle outside, that is, ambient air, is taken in the supply-air equipment 20 via the supply-air duct 50 and the duct 26, and is supplied to the air conditioner 3 directly from the supply-air equipment 20 via the supply-air duct 51 and the duct 58 in this sequential order. Therefore, ambient air introduced from outside the vehicle is not caused to be supplied to the air conditioner after it has passed the driving motor portion of the supply-air equipment of the conventional structure. That is, heat generated by the motor 11 does not heat ambient air to be supplied to the duct 51, the cooling load of the air conditioner 3 is prevented from being increased.

In addition, room air whose temperature has been always conditioned at a constant level by the air conditioner 3 is taken in the case 12 by the exhaust-air equipment 30 via the exhaust-air ducts 52 and 53, the ducts 56 and 41 in this sequential order. Air which has been thus-introduced into the case 12, that is, exhaust air, is made pass through the case 12 by the exhaust-air equipment 30, and is exhausted to the outside the vehicle via the duct 44 and the exhaust-air equipment 30 in this sequential order. In this state, when room air is exhausted outside the vehicle after it has passed through the driving device 10, exhaust air which passes through the case 12 absorbs heat generated by the motor 11. As a result, since the motor 11 is cooled down by the exhaust air to be exhausted from car inside to the outside by the exhaust-air equipment 30, this motor 11 can be effectively cooled down. The structure described above is advantageous when a vehicle is operated with a cooling operation in a high temperature regions. The reason for this lies that the motor 11 can be cooled down by air in the room whose temperature is lower than that of the ambient air. Since exhaust air to be introduced into the case 12 contains the dust in the car room, it is preferable for the same to be introduced into the case 12 via a filter or the like. In addition, since exhaust air to be exhausted from car room to the outside the vehicle is air which is before being compressed and the pressure thereof is raised by the blower 31, the temperature thereof is the same level as that in the car room. The exhaust air which has been compressed and whose pressure has been raised by the blower 31 raises its temperature. Therefore, the motor 11 can be further effectively cooled down with respect to the efficiency of cooling the motor 11 by exhaust air which has passed through the blower 31.

The ventilating equipment for a vehicle structured as described above exhibits the following characteristics. That is, a supply-air equipment 20 is provided on one side of the driving device 10, while an exhaust-air equipment 30 is provided on the other side of the driving device 10. As a result of this, the supply-air equipment 20 and the exhaust-air equipment 30 can be integrated in one unit and thereby displaced in one place. Therefore, individually disposing the supply-air equipment and the exhaust-air equipment on the roof of the vehicle and the under floor of the same becomes unnecessarily. As a result, the space needed to locate the ventilating equipment, that is, the size of the ventilating equipment can be minimized. In addition, since respectively providing a driving motor for the supply-air equipment and for the exhaust-air equipment becomes unnecessarily, the size of the ventilating equipment can be reduced. Furthermore, since the partition walls 16 and 17 are used commonly as the individually separating the air passage spaces between the motor 11 and the blower 21 and between the motor 11 and the blower 31, it is further advantageous for reducing the size of the ventilating equipment.

In addition, since the frame in the bottom portion of the vehicle 1 is as well used as the duct, the space under the floor of the vehicle can be effectively utilized. In addition, by combining the above-described effect and the thus-size reduced ventilating equipment, the ventilating equipment can be disposed under the floor of the vehicle 1. As a result, the conventional necessity of providing the supply-air equipment on the roof of the vehicle becomes needless.

In the space starting from the exhaust-air blower 31 and reaching the room, the ducts 36 and 44, case 12, ducts 41, 56 and 53 are interposed. Therefore, the distance from the exhaust-air blower to the car room is longer than the conventional ones. Therefore, the noise caused from the exhaust-air blower is made difficult to be transmitted to the car room. In addition, by providing a sound absorbing material in the ducts 26 and 36, a further improved sound absorption effect can be obtained.

In the above-described embodiment, a case in which no component is added to the ducts 26 and 36 is described. However, a structure may be employed that a air flow passage adjustable means is provided in the duct 26 and at the outlet port 35 as to adjust the pressure change which is transmitted by the ambient air pressure change to the car inside. As a result, the level of the pressure which can be endured by the supply-air equipment 20 and the exhaust-air equipment 30 can be lowered. In addition, the position at which the pressure absorbing device may be determined at any position

on the intake side of the supply-air equipment 20 as an alternative to the position in the duct 26. In a case where the air flow passage adjustable means is provided on the intake side of the supply-air equipment 20 and on the discharge side of the exhaust-air equipment 30 respectively, required pressure level for ventilating equipment can be lowered. As the air flow passage adjustable means, there is a type as disclosed in Japanese Patent Laid-Open No. 62-299475, and arranged in such a manner that a plurality of plate-like elastic members cantilevered are arranged alternately, and these plate-like elastic members are arranged to be deflected by the pressure change so that the air flow is restricted for the purpose of adjusting the pressure change.

The high pressure blower used for the supply-air equipment 20 according to the first embodiment and the exhaust-air equipment 30 are determined by the ambient air pressure change to which the vehicle is subjected.

In the above-described first embodiment, the outlet port 35 of the exhaust-air equipment 30 is faced downward. However, the outlet port 35 of the exhaust-air equipment 30 is not limited by this description. In addition, if a structure is employed that room air to be exhausted through the outlet port 35 is made to be sent to the heat exchanging portion of the air conditioner 3, the heat exchange efficiency of the air conditioner 3 can be improved, and thereby the load to be applied to the air conditioner can be reduced. In this state, since the room air to be exhausted through the outlet port 35 has been dusty, it is preferable for air to be cleaned by using a filter or the like.

In the first embodiment, the supply-air port for taking ambient air is provided in the end of the vehicle 1. However, it is not limited to this position, it may be located at any position in the outer wall of the vehicle. If the supply-air port is provided in the end of the vehicle 1, dust or snow which is raised during running can be prevented from being taken in.

In this first embodiment, the ventilating equipment is disposed under the floor of the vehicle 1. However, the position at which the ventilating equipment is disposed is not limited to this description. It may be disposed on the roof of the vehicle or in a partial portion of the inside of the vehicle. If the ventilating equipment is disposed under the floor of the vehicle 1, the center of gravity of the vehicle 1 can be, to a certain degree, lowered, causing an advantage when the vehicle is operated at a high speed.

In the above-described first embodiment, air to be exhausted from the car room, that is, exhaust air, is arranged to cool the motor 11. However, the above-described structure of the duct in which the

ducts 41 and 44 secured between the exhaust-air equipment 30 and the driving device 10 may be alternatively disposed between the supply-air equipment 20 and the driving device 10 for the purpose of having the motor 11 cooled down by the air on the outside the vehicle, that is by the ambient air. The supply-air equipment to take air from the car outside sends the ambient air to the car inside via the duct 41, case 12, ducts 44 and 26, blower 21 and the outlet port 25 in this sequential order. The exhaust-air equipment to exhaust air from the car room exhausts air to the outside of the vehicle via the duct 36, blower 31, and the outlet port 35 in this sequential order. According to this structure, since the motor 11 is not cooled by exhaust air, the motor 11 can be protected from adhesion of dust or the like, so that the cleaning work at the time of maintaining the equipment can be made easier. When the air conditioner is operated in the heating mode, air to be taken in the air conditioner is, to a certain degree, heated by the motor 11, and the load to be applied to the air conditioner can be reduced. The structure described above is advantageous when a vehicle is operated with a heating operation in a low temperature regions. The reason for this lies in that the motor 11 can be cooled down by ambient air whose temperature is lower than that of the room.

As described above, according to the first embodiment, an effect can be obtained that the size of the equipment can be reduced so that the space needed to locate it can be also reduced.

In addition, effects can be obtained that the space needed to locate the equipment can be reduced, and the driving motor for the ventilating equipment can be effectively cooled.

Next, a second embodiment of the present invention will be described with reference to Figs. 7 and 8.

Referring to Figs. 7 and 8, the same referential numerals as those in Figs. 1 to 3 represent the same components. Since the structure and the operation of these components are the same as those in the first embodiment, the description upon them is omitted.

The first difference between this embodiment and the first embodiment lies in that the inlet port 13 of the case 12 and the outlet port 35 of the case 33 are connected to each other by a duct 47. The outlet port 35 of the case 33 is arranged to face the same direction as that of the inlet port 13 of the case 12. The direction of the outlet port 35 can be changed by changing the direction of the case 33 in which the same is secured to the partition wall 17. An end of the duct 47 is provided with an opening 48, while another end of the same is provided with an opening 49. The duct 47 is secured in such a manner that the opening 48 and

the outlet port 35 are connected to each other, and the opening 49 and the inlet port 13 are connected to each other. The second difference lies in that a air flow passage adjustable means 80 is connected to the outlet port 14 of the case 12. The third difference lies in that a air flow passage adjustable means 81 is provided in the duct 26. The air flow passage adjustable means 80 and 81 comprise the air flow passage adjustable means disclosed in Japanese Patent Laid-Open No. 62-299475 and described in the aforementioned embodiment. The fourth difference lies in that the opening 37 of the duct 36 is faced upward. The direction of the opening 37 can be changed by changing the direction in which the duct 33 is secured to the duct 36.

According to thus-structured ventilating equipment, air can be flow as follows by the operation of the driving device 10. On the supply-air equipment 20 side, air is first introduced into the duct 26 through the opening 27 of the duct 26 via the air flow passage adjustable means 81. Air introduced into the duct 26 is discharged through the outlet port 25 of the case 23 via the supply-air equipment 20. On the exhaust-air equipment 30 side, air is first introduced into the duct 36 through the opening 37 of the duct 36. Air introduced into the duct 36 is discharged through the outlet port 35 into the duct 47 via the exhaust-air equipment 30. Air introduced into the duct 47 through the opening 48 is introduced into the case 12 via the opening 49 and the inlet port 13. Air introduced into the case 12 is then exhausted through the outlet port 14. Air exhausted from the outlet port 14 is exhausted to the outside the vehicle via the air flow passage adjustable means 80.

The thus-structured ventilating equipment is, similarly to the first embodiment, and as shown in Figs. 5 and 6, disposed under the floor of the vehicle 1, and is connected to the duct disposed in this under floor portion. In this state, an opening 74 disposed in the duct 56 which as well serves as the body structure of the vehicle 1 is connected to the opening 37 after the position thereof has been changed to the position above the opening 37 of the duct 36 of the ventilating equipment.

With the ventilating equipment structured as described above, the ventilation is conducted as follows: the process starting from that ambient fresh air is supplied through the duct 50 of the vehicle 1 to that air in the room is exhausted to the duct 56 of the vehicle 1 is the same as that of the first embodiment, therefore, the description upon it is omitted. Air from the room, that is, exhaust air, which has been introduced into the duct 56, is exhausted after it has cooled the motor 11 in the driving device 10 via the exhaust-air equipment 30.

In this second embodiment, air to be exhausted from the room, that is, exhaust air, is arranged

to cool the motor 11. However, the structure of the duct according to this second embodiment may be replaced by a structure in which the dust 47 disposed between the exhaust-air equipment 30 and the driving device 10 may be disposed between the supply-air equipment 20 and the driving device 10 so that the motor 11 is cooled by the air from the outside the vehicle, that is, by the ambient air. The supply-air equipment which takes air from the car outside sends ambient air to the room via the duct 26, blower 21, outlet port 25, duct 47, case 12, and the outlet port 14 in this sequential order. The exhaust-air equipment which exhausts air from the room exhausts exhaust air to the outside of the vehicle via the duct 36, blower 31, outlet port 35, and the air flow passage adjustable means 80 in this sequential order. As a result of the thus-formed structure, since the exhaust air does not cool the motor 11 as described above, the motor 11 can be prevented from adhesion of dust or the like, so that the cleaning work at the time of performing equipment maintenance can be made easier. Furthermore, since air to be introduced into the air conditioner can be, to a certain degree, heated by the motor 11 when the air conditioner is operated in the heating mode, the lead to be applied to the air conditioner can be reduced. The structure described above is advantageous when a vehicle is operated with a heating operation in a low temperature regions. The reason for this lies in that the motor 11 is cooled by ambient air whose temperature is lower than that of the room.

As described above, according to the second embodiment, the similar operation and effect can be obtained to the above-described embodiment. In addition, the size of the duct to be secured to the ventilating equipment can be reduced, causing for the duct to be constituted with a simple structure. Consequently, an effect can be obtained that the overall ventilating equipment can be formed with a simple structure.

Next, a third embodiment of the present invention will be described with reference to Figs. 9 and 10.

The ventilating equipments according to the first and second embodiments are arranged to accommodate the motor 11 in an air passage space which is arranged individually and separated by the case 12, partition walls 16 and 17 as shown in Fig. 1. The present invention is, as shown in Figs. 9 and 10, a motor 11a with greater size flanges 18 and 19 and case 12a can form an air passage space. In this case, a mount base 15a is provided above the flanges 18 and 19. Between the flanges 18 and 19, a case 12a is secured as to surround the motor 11a. On a side surface of the case 12a, an inlet port 13a is provided, while on the other side surface of the case 12a, an outlet port 14 a is pro-

vided. In an end portion of the driving shaft which passes through the flange 18, a blower 21a is inserted and thereby secured. In an end portion of the driving shaft which passes through the flange 19, a blower 31a is inserted and is thereby secured. At an extreme end of the driving shaft, a stopper plate 22 is secured. In another end portion of the driving shaft, a stopper plate 32 is secured. In an end surface of the flange 18, a case 23a is secured as to cover the blower 21. In the central portion of the case 23a, an inlet port 24a is provided. In the periphery of the case 23a, an outlet port 25a is provided. In an end surface of the flange 19, a case 33a is secured as to cover the blower 31a. In the central portion of the case 33a, an inlet port 34a is provided. In the periphery of the case 33a, an outlet port 35a is provided. In this case, a driving device 10a comprises the motor 11a and the case 12a. A supply-air equipment 20a comprises the flange 18, blower 21a and the case 23a. A exhaust-air equipment 30a comprises the flange 19, blower 31a and the case 33a.

The ventilating equipment structured as described above can be operated similarly to that describe in the above-described first embodiment by rotating the motor 11a. This ventilating equipment can be similarly operated to that described in the first embodiment or the second embodiment by changing the combination of the connection.

As described above, according to the third embodiment, the similar effect to that obtained by the first and second embodiments can be obtained. In addition, since the driving device 10a of this ventilating device is arranged in such a manner that the flanges 18 and 19 of the motor 11a as well serves as the partition walls 16 and 17 described in the first and second embodiments, an effect can be obtained that the width of the driving device 10a can be further reduced, so that the size of the ventilating equipment can be further reduced.

Then, the fourth embodiment of the present invention will be described with reference to Figs. 11 and 12.

Referring to Figs. 11 and 12, the same reference numerals as those in Figs. 1 and 7 represent the same components. Since the same components has the same structure and operates similarly to each other, the description is omitted. The first difference from the second embodiment lies in that a fan 31b inserted into the other shaft is arranged to supply air in the axial direction. The second difference lies in that only one opening is formed in the side surface of the case 12b surrounding the motor 11. In this case, this opening comprises the outlet port 14. The third difference lies in that a case 33b surrounding the lower 31b is secured to an end of the other opening in the case 12b. The case 12b and the case 33b are commu-

5 nicated to each other. A duct 36b is secured to the inlet port 34 of the case 33b. The opening 37 disposed in the upper portion of the duct 36b and the outlet port 14 of the case 12b is connected to each other. In this case, this driving device 10b, together with the exhaust-air equipment, forms an exhaust-air equipment 30b.

10 With the ventilating equipment structured as described above, air is passed by the operation of the motor 11 as follows: on the supply-air equipment 20 side, air is first introduced through the opening 27 of the duct 26 into the duct 26. Air introduced into the duct 26 is exhausted through the outlet port 25 of the case 23 via the supply-air equipment 20. On the exhaust-air equipment 30b side, air is first introduced into the duct 36b through the opening 37 of the duct 36b. Air introduced into the duct 36b is sent to the case 12b inside via the fan 31b. Air introduced into the case 12b is exhausted from the outlet port 14 after it has passed though the case 12b. Air exhausted from the outlet port 14 is discharged outside via the air flow passage adjustable means 80. In this case, if the pressure of the exhaust-air equipment including the blower 31b can be raised up to the level similar to that of the change of the ambient air pressure, the air flow passage adjustable means 80 may be omitted.

30 The thus-formed ventilating equipment is, similarly to that described in the first embodiment, and as shown in Fig. 5 and 6, disposed under the floor of the vehicle 1, and is connected to the duct under the floor. In this case, the opening 74 formed in the duct 56 which as well serves as the structure body of the vehicle 1 is connected to the opening 37 after it has changed its position to the position above the opening 37 of the duct 36a of the ventilating equipment.

40 The ventilation is conducted as follows with the thus-formed ventilating equipment for a vehicle: since the process starting from that fresh ambient air is supplied to the room through the duct 50 of the vehicle 1 to that the air in the room is exhausted to the duct 56 of the vehicle 1 is the same as that in the first embodiment, therefore, the description is omitted. The air from the room introduced into the duct 56 is exhausted via the exhaust-air equipment 30b. In this state, the motor 11 is cooled when air passes through the exhaust-air equipment 30b.

50 In this fourth embodiment, the route through which air in the room is exhausted is arranged to be exhausted after it has cooled the motor 11 via the blower 31b. However, it may alternatively arranged in such a manner that it is exhausted via the blower 31b after it has cooled the motor 11.

55 In this fourth embodiment, air to be exhausted from the vehicle inside, that is, the exhaust air, is

arranged to cool the motor 11. However, a structure may be employed that the supply-air equipment 20 of the fourth embodiment is made the exhaust-air equipment, while the exhaust-air equipment 30b of the same is made the supply-air equipment, so that the motor 11 is arranged to be cooled by air from outside the vehicle, that is, by ambient air. The supply-air equipment side which takes air from outside the vehicle sends ambient air to the room via the duct 36b, blower 31b, case 12b and the outlet port 14 in this sequential order. The exhaust-air side which discharges air from the room exhausts air via the duct 26, blower 21, and the outlet port 25 in this sequential order. As a result, the operation and effect obtained in the above-described discriptions can be obtained.

According to the fourth embodiment, the similar effects and operation can be obtained, and the duct for sending cooling air for the motor 11 becomes needless, causing the structure to be made simple. Consequently, the overall structure of the ventilating equipment can be arranged in a significantly simple manner.

Further embodiments of the present invention will be described with reference to Fig. 13.

The ventilating equipments described above are, as shown in Fig. 13 (a), structured in such a manner that the supply-air equipment 20 is disposed to an end of the driving device 10, while the exhaust-air equipment 30 is disposed to the other end of the same, they being connected to each other. In addition, the arrangements as shown in from Fig. 13 (b) to 13 (f) may be employed. Fig. 13 (b) illustrates a structure arranged in such a manner that the supply-air equipment 20 and the exhaust-air equipment 30 are connected to an end of the driving device 10. Figs. 13 (c) illustrates a structure arranged in such a manner that the supply-air equipment 20 is disposed to one side to the driving device 10, while the exhaust-air equipment 30 is disposed to the other side to the driving device 10, they respectively being connected to the corresponding driving shafts at ends of the driving device 10 with a transmission device 90. Fig. 13 (d) illustrates a structure arranged in such a manner that the supply-air equipment 20 and the exhaust-air equipment 30 are disposed to one side to the driving device 10, they being respectively connected to the driving shafts at ends of the driving device 10 with the transmission device 90. Fig. 13 (e) illustrates a structure arranged in such a manner that the supply-air equipment 20 and the exhaust-air equipment 30 are respectively disposed on one side to the driving device 10, the supply-air equipment 20 being connected to the driving shaft at an end of the driving device 10 with a transmission device 91, and the exhaust-air equipment 30 being connected to the driving shaft at the other

end of the driving device 10 with the transmission device 91. Fig. 13 (f) illustrates a structure arranged in such a manner that the supply-air equipment 20 is disposed on one side to the driving device 10, while the exhaust-air equipment 30 is disposed on the other side to the same, the supplying-air equipment 20 being connected to the driving shaft at an end of the driving device 10 with the transmission device 91, and the exhaust-air equipment 30 being connected to the driving shaft at the other end of the driving device 10 with the transmission device 91.

In this case, in the ventilating equipments described above, the partition wall between the air passage space in the supply-air equipment 20 and the air passage space in the driving device 10, or the partition wall between the air passage space in the exhaust-air equipment 30 and the air passage space in the driving device 10 is separated by a common wall. However, referring to Fig. 13, these partition walls may be individually separated.

According to the present invention, and as described above, the overall size of the ventilating equipment can be minimized and the space needed to locate it can thereby be reduced by connecting the supply-air equipment and the exhaust-air equipment to one driving device.

Furthermore, the overall size of the ventilating equipment can be minimized, the space needed to locate it can thereby be reduced, and the driving motor for the ventilating equipment can be effectively cooled by connecting the supply-air equipment and the exhaust-air equipment to one driving device and by cooling the driving device by room air to be exhausted to the outside of the vehicle.

In addition, the overall size of the ventilating equipment can be minimized, the space needed to locate it can thereby be reduced, and the driving motor for the ventilating equipment can be effectively cooled by connecting the supply-air equipment and the exhaust-air equipment to one driving device and by cooling the driving device by ambient air to be supplied to the room of the vehicle.

## Claims

1. A ventilating equipment for a vehicle provided for a vehicle whose ambient air pressure is suddenly changed when this vehicle runs, and acts to supply ambient air to the inside of the vehicle and as well exhaust room air to the outside of the vehicle, said ventilating equipment for a vehicle characterized by:  
a supply-air equipment (20) and an exhaust-air equipment (30) connected to one driving device (11).

2. A ventilating equipment for a vehicle according to claim 1, characterized in that a blower (21) of said supply-air equipment (20) is secured to one side of a driving shaft of said driving device (11), while a blower (31) of said exhaust-air equipment (30) is secured to the other side of said driving shaft.

3. A ventilating equipment for a vehicle according to claim 1, characterized in that the air passage space for said supply-air equipment (20) and the same of said exhaust-air equipment (30) are formed individually.

4. A ventilating equipment for a vehicle according to claim 1, characterized in that the air passage space for said driving device (11) and the same for said exhaust-air equipment (30) are made continuous, and the air passage space for said supply-air equipment (20) is formed individually.

5. A ventilating equipment for a vehicle according to claim 1, characterized in that the air passage space for said driving device (11) and the same for said supply-air equipment (20) are made continuous, and the air passage space for said exhaust-air equipment (30) is formed individually.

6. A ventilating equipment for a vehicle according to claim 1, characterized in that said ventilating equipment for a vehicle is disposed under the floor of said vehicle (1).

7. A ventilating equipment for a vehicle provided for a vehicle whose ambient air pressure is suddenly changed when this vehicle runs, and acts to supply ambient air to the inside of the vehicle and as well exhaust room air to the outside of the vehicle,

said ventilating equipment for a vehicle characterized by:

a supply-air equipment (20) and an exhaust-air equipment (30) connected to one driving device (11), wherein said driving device (11) is cooled by room air to be exhausted to the outside of the vehicle.

8. A ventilating equipment for a vehicle according to claim 7, characterized in that air to cool said driving device (11) is air which is then to be introduced into said exhaust-air equipment (30).

9. A ventilating equipment for a vehicle according to claim 7, characterized in that air to cool said driving device (11) is air which has been discharged from said exhaust-air equipment (30).

10. A ventilating equipment for a vehicle disposed in the vehicle whose ambient air pressure is suddenly changed when this vehicles runs, and acts to supply ambient air to the room of the vehicle, and as well acts to exhaust room air to the outside of the vehicle,

said ventilating equipment for a vehicle characterized by:

a supply-air equipment (20) and an exhaust-air

equipment (30) to be connected to one driving device (11), wherein said driving device (11) is cooled by ambient air to be supplied to said room of said vehicle.

11. A ventilating equipment for a vehicle according to claim 10, characterized in that air to cool said driving device (11) is air which is then to be introduced into said supply-air equipment (20).

12. A ventilating equipment for a vehicle according to claim 10, characterized in that air to cool said driving device (11) is air which has been discharged from said supply-air equipment (20).

5

10

15

20

25

30

35

40

45

50

55

FIG. 1

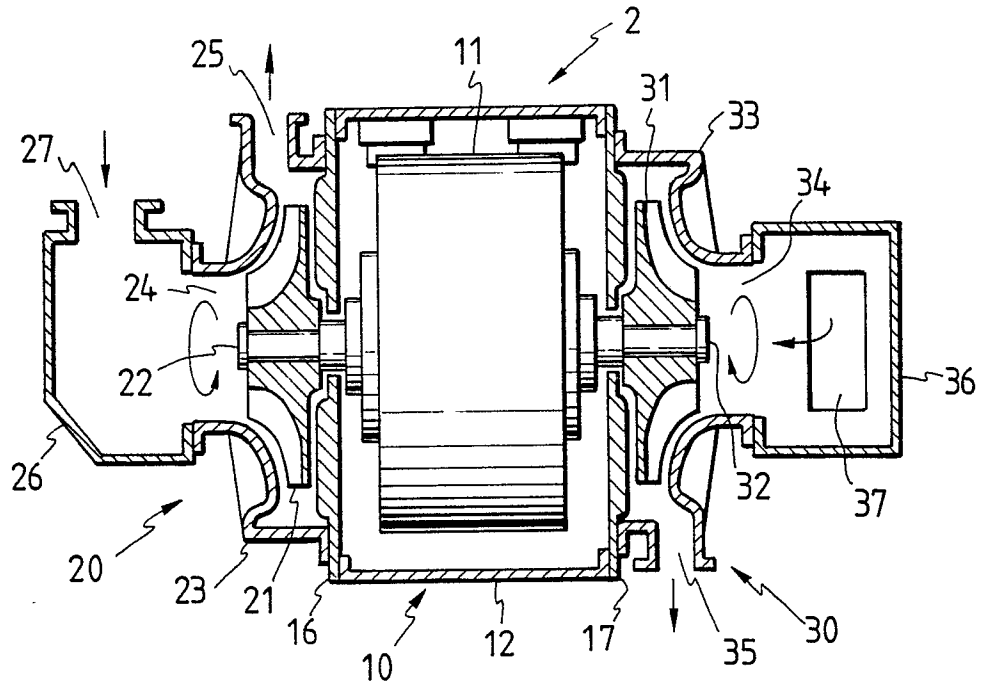

FIG. 2

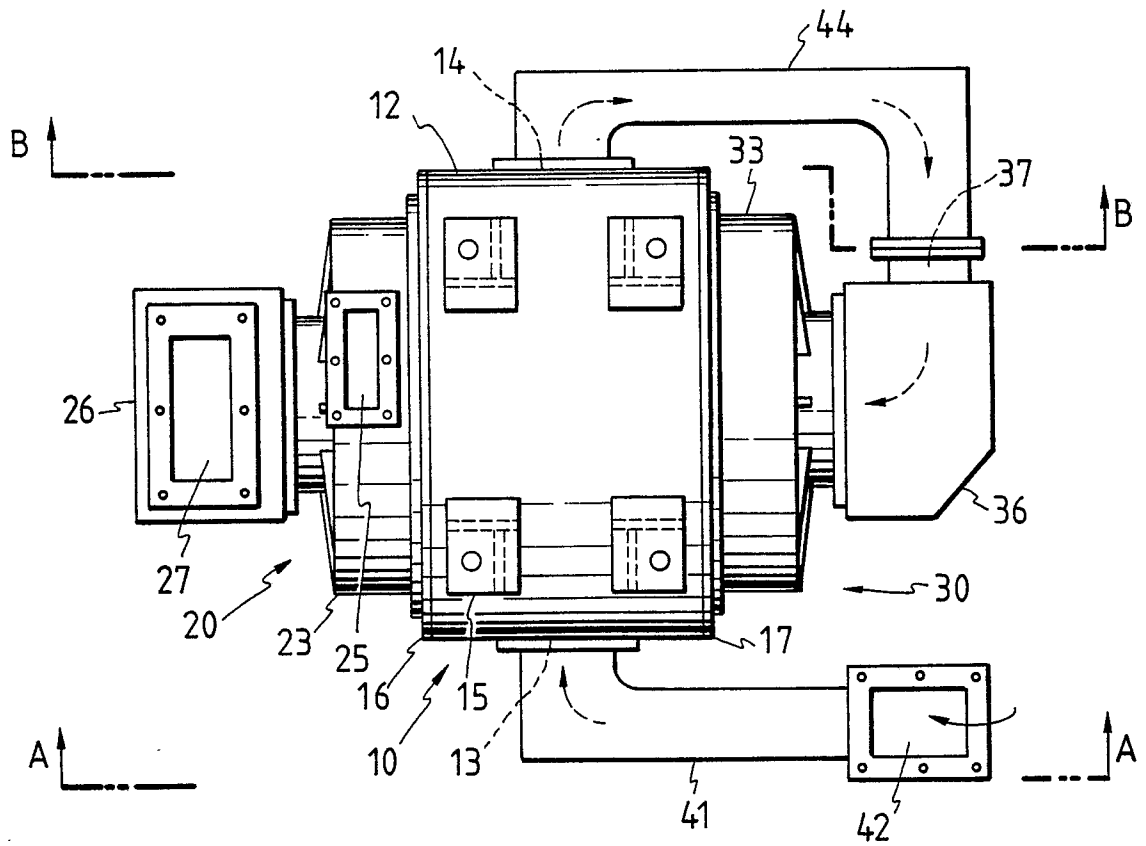

FIG. 3



FIG. 4

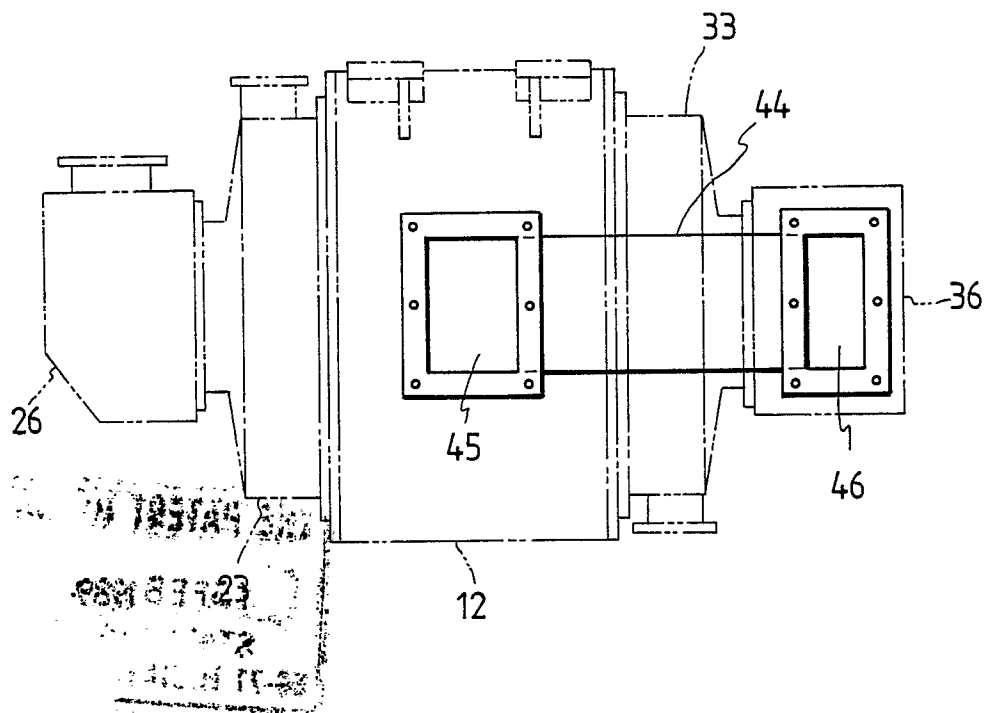

FIG. 5

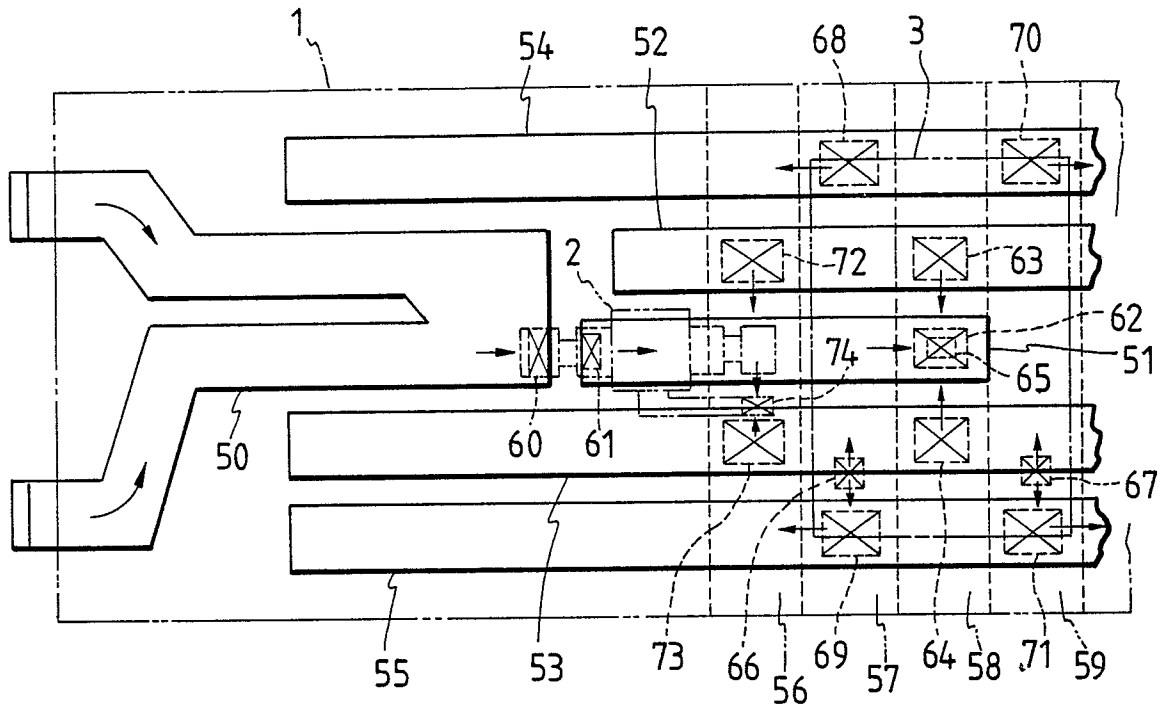

FIG. 6

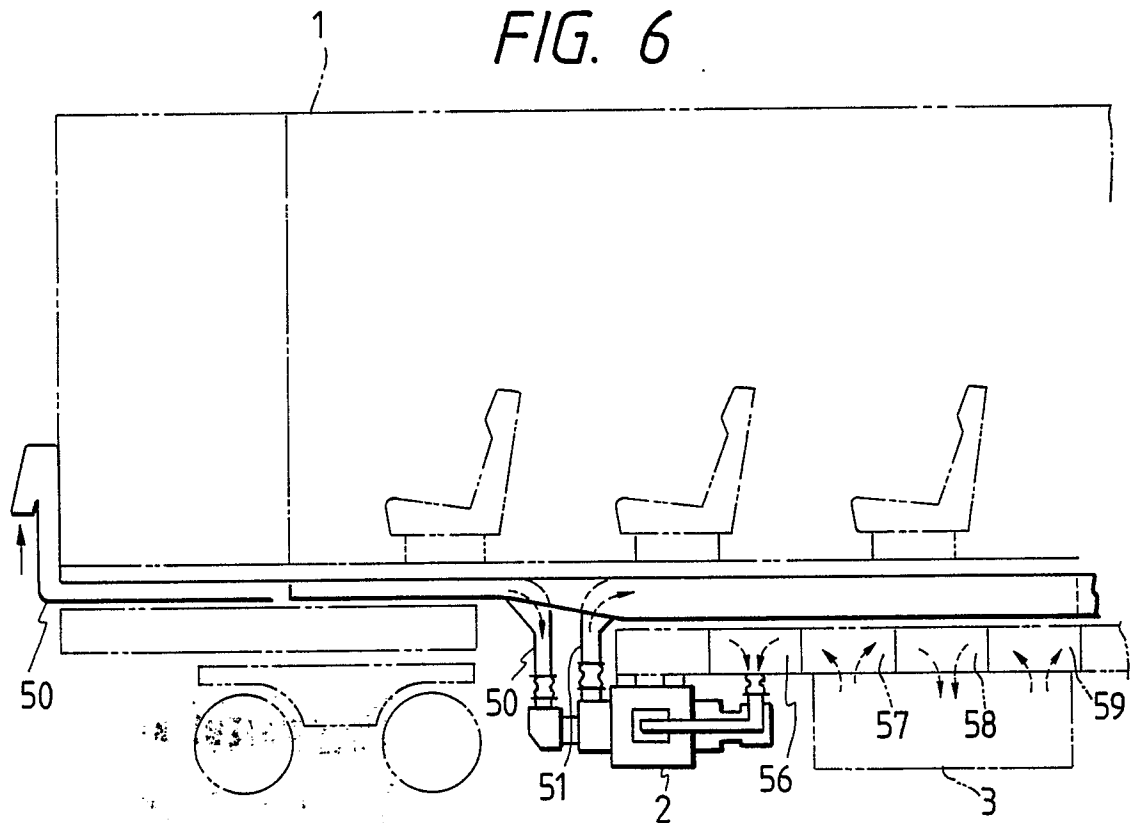

FIG. 7

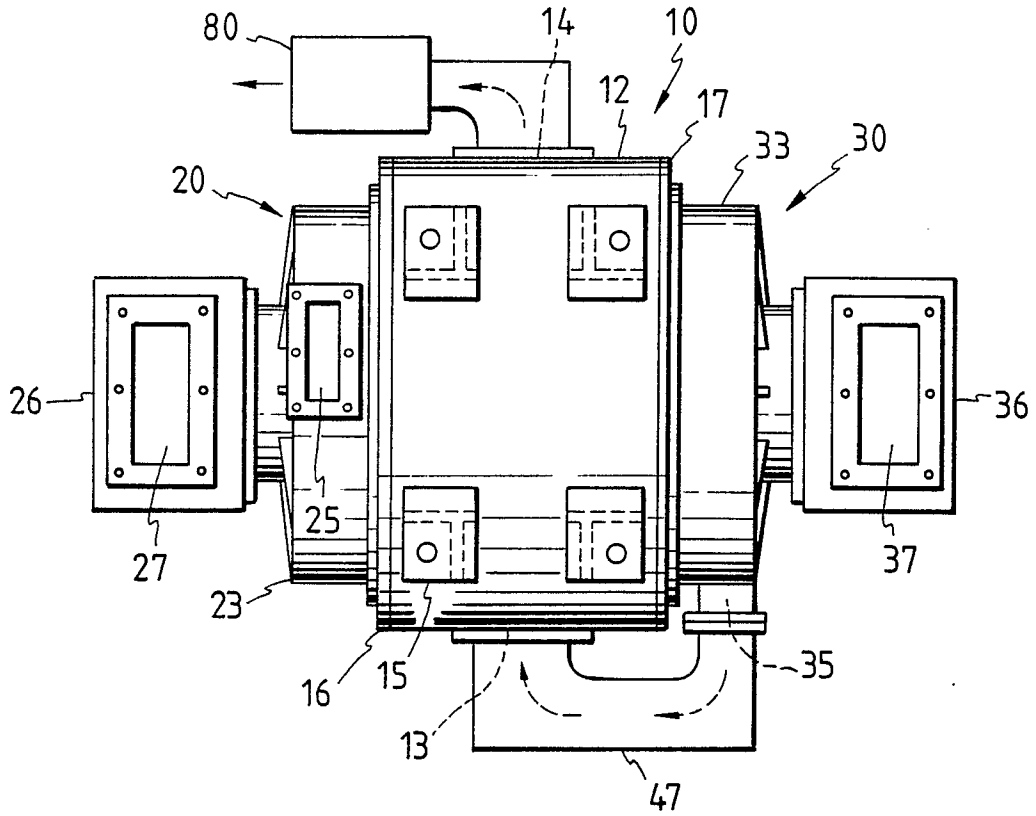

FIG. 8

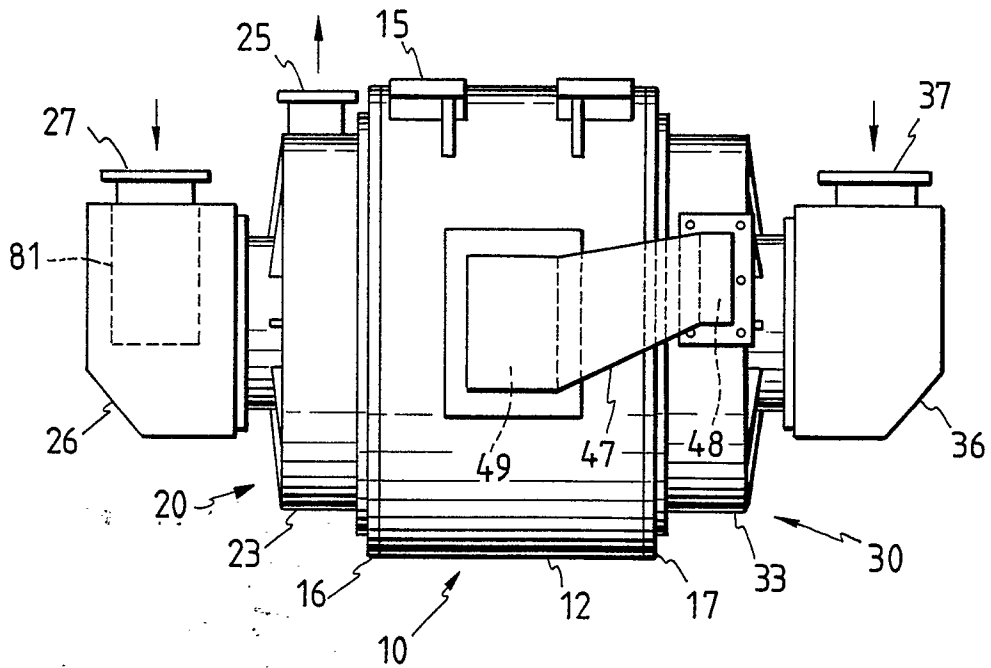

FIG. 9

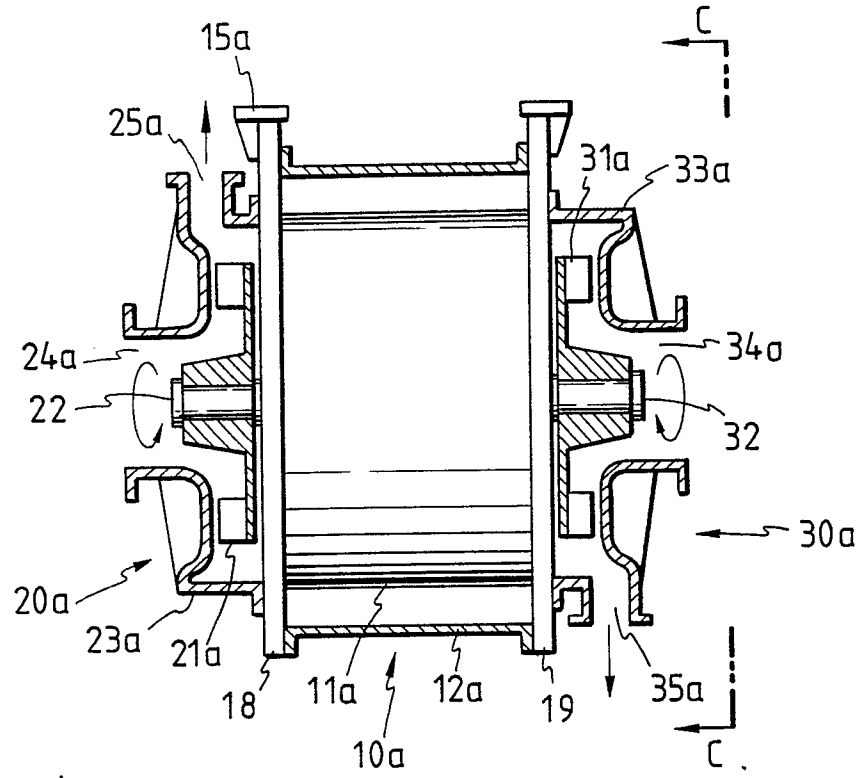

FIG. 10

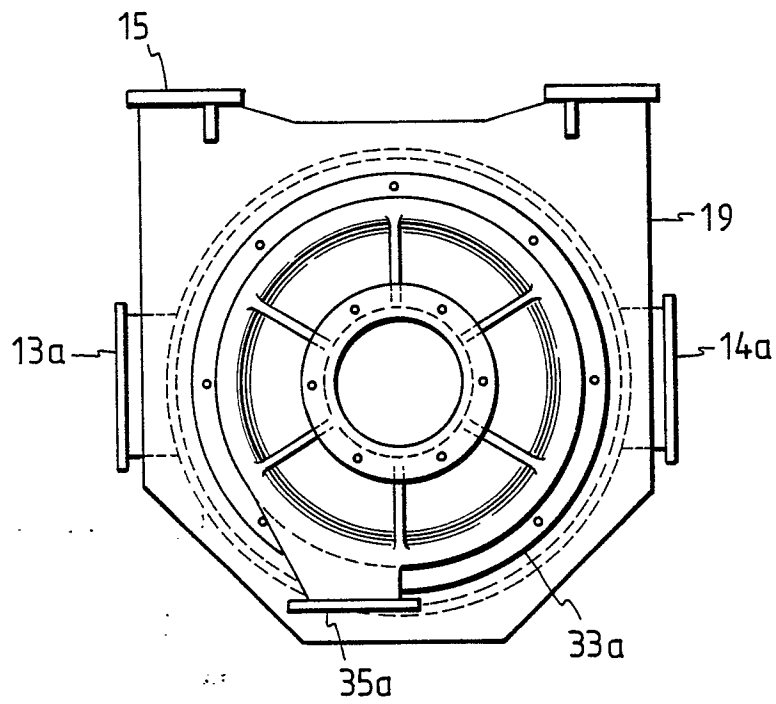

FIG. 11

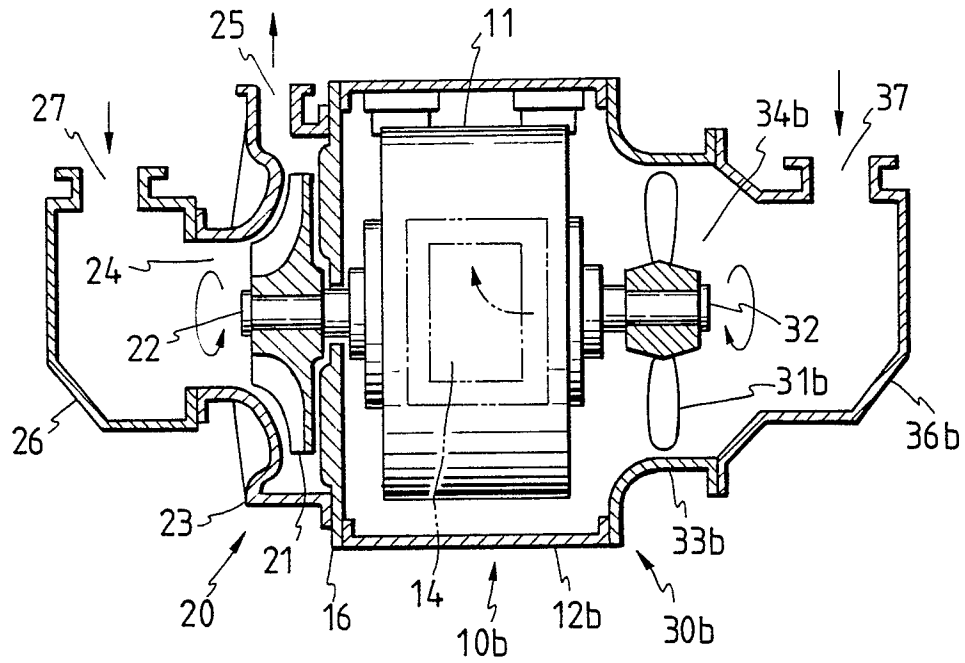

FIG. 12

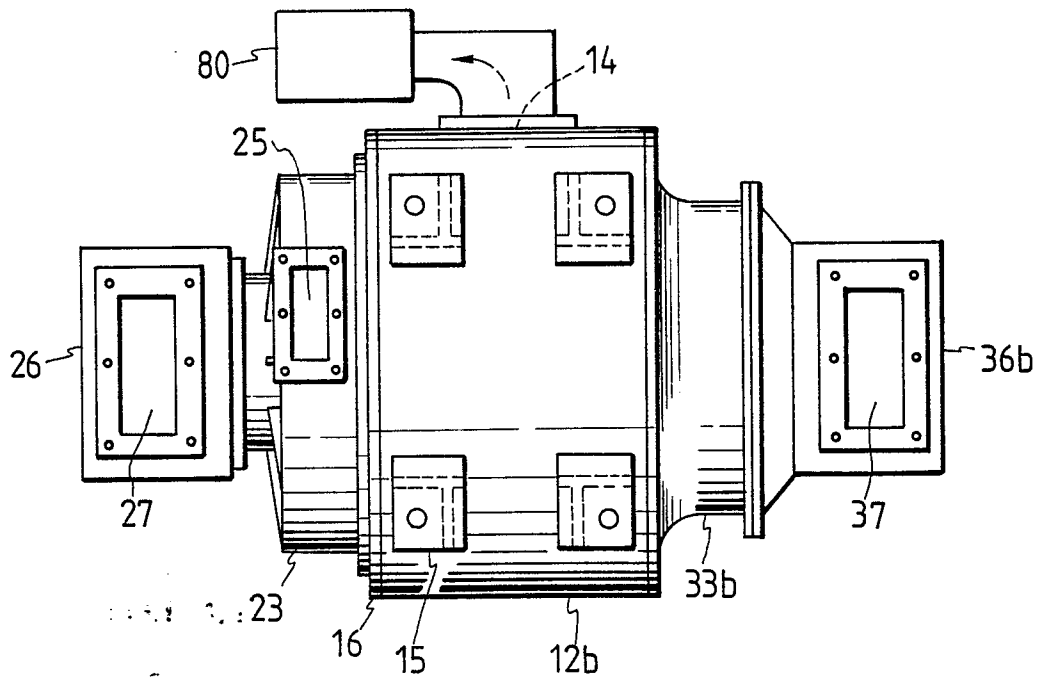

FIG. 13(a)

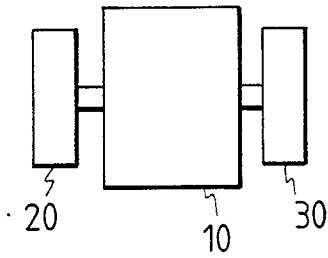

FIG. 13(b)

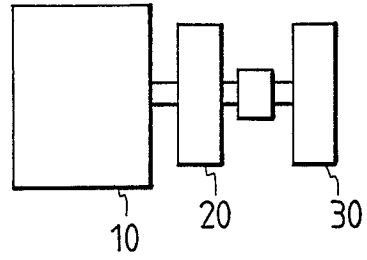

FIG. 13(c)

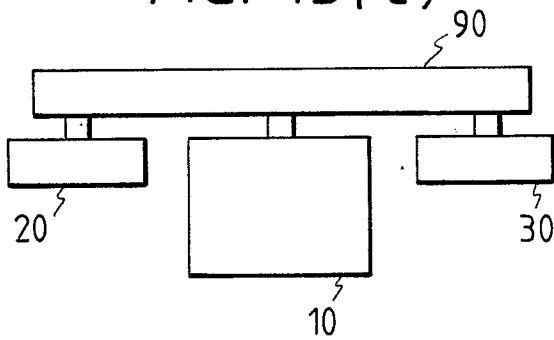

FIG. 13(d)

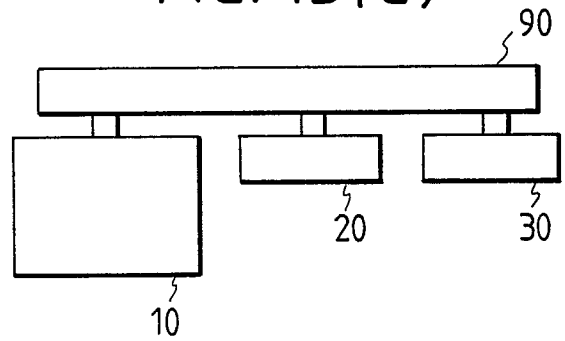

FIG. 13(e)

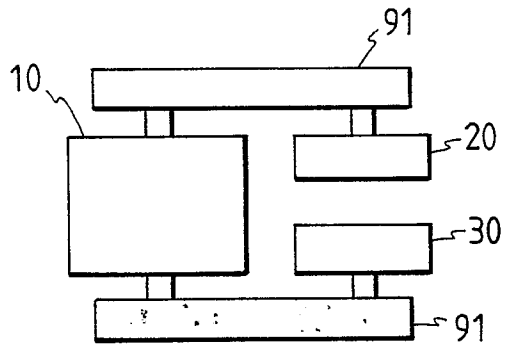
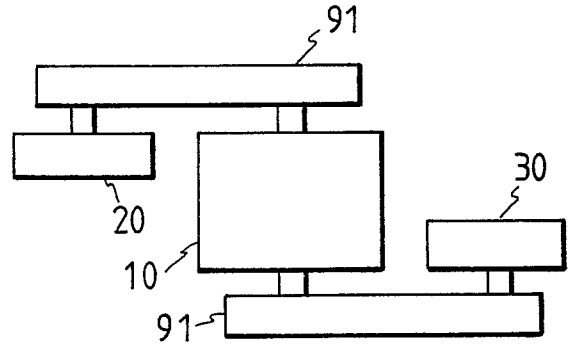

FIG. 13(f)





DOCUMENTS CONSIDERED TO BE RELEVANT			
Category	Citation of document with indication, where appropriate, of relevant passages	Relevant to claim	CLASSIFICATION OF THE APPLICATION (Int. Cl. 4)
A	US-A-2 000 841 (W.H. HERDLEIN) * Figures 1-3; column 2, lines 34-49 * ----	1,5,10	B 61 D 27/00
A	DE-B-1 108 099 (O. FRITSCH) * Figure 1; column 1, line 43 - column 2, line 23 * ----	1,5,10	
A	DE-C- 669 667 (BROWN, BOVERI & CIE AG) * Figures 1-3; page 1, line 48 - page 2, line 31 * -----	1,5,10	
The present search report has been drawn up for all claims			TECHNICAL FIELDS SEARCHED (Int. Cl.4)
			B 61 D B 60 H
Place of search	Date of completion of the search	Examiner	
THE HAGUE	26-10-1989	CHLOSTA P.	
CATEGORY OF CITED DOCUMENTS		T : theory or principle underlying the invention E : earlier patent document, but published on, or after the filing date D : document cited in the application L : document cited for other reasons ..... & : member of the same patent family, corresponding document	
X : particularly relevant if taken alone Y : particularly relevant if combined with another document of the same category A : technological background O : non-written disclosure P : intermediate document			