



(11) **EP 1 808 929 A1**

(12) **EUROPEAN PATENT APPLICATION**

(43) Date of publication:
18.07.2007 Bulletin 2007/29

(51) Int Cl.:
H01Q 1/24 (2006.01) H01Q 19/28 (2006.01)
H01Q 19/22 (2006.01)

(21) Application number: **06250180.4**

(22) Date of filing: **13.01.2006**

(84) Designated Contracting States:
AT BE BG CH CY CZ DE DK EE ES FI FR GB GR HU IE IS IT LI LT LU LV MC NL PL PT RO SE SI SK TR
Designated Extension States:
AL BA HR MK YU

- **Cooke, Adrian**
Kitchener, Ontario N2A 4B5 (CA)
- **Man, Ying Tong**
Waterloo, Ontario N2V 2V8 (CA)
- **Jarmuszewski, Perry**
Waterloo, Ontario N2L 2N7 (CA)

(71) Applicant: **Research In Motion Limited**
Waterloo, Ontario N2L 3W8 (CA)

(74) Representative: **Fennell, Gareth Charles et al**
Kilburn & Strode
20 Red Lion Street
London WC1R 4PJ (GB)

(72) Inventors:
• **Qi, Yihong**
St. Agatha, Ontario N0B 2L0 (CA)

Remarks:
Amended claims in accordance with Rule 86 (2) EPC.

(54) **Mobile wireless communications device including an electrically conductive director element and related methods**

(57) A mobile wireless communications device may include a portable housing, a printed circuit board (PCB) carried by the portable housing, a wireless transceiver carried by the PCB, and an antenna connected to the transceiver and carried by the PCB. The mobile wireless communications device may further include at least one director element (30) for directing a beam pattern of the antenna. More particularly, the at least one director element may include an electrically conductive main branch carried by the portable housing, and an electrically conductive connector portion extending between the main branch and the PCB.

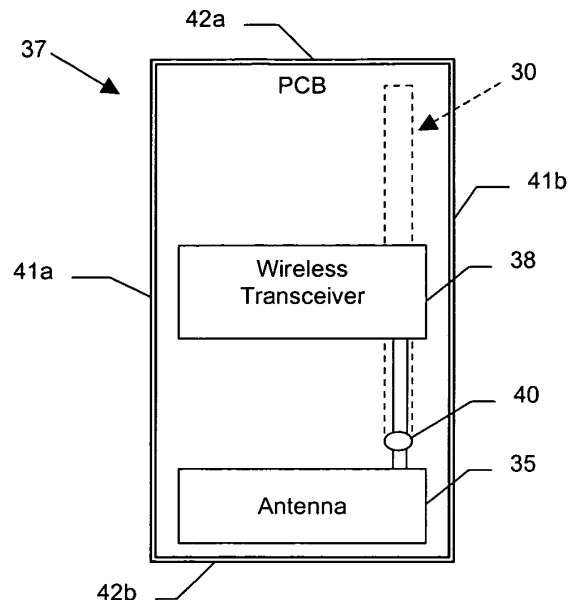

FIG. 2

EP 1 808 929 A1

Description

Field of the Invention

[0001] The present invention relates to the field of communications devices, and, more particularly, to mobile wireless communications devices and related methods.

Background of the Invention

[0002] Cellular communications systems continue to grow in popularity and have become an integral part of both personal and business communications. Cellular telephones allow users to place and receive voice calls most anywhere they travel. Moreover, as cellular telephone technology has increased, so too has the functionality of cellular devices and the different types of devices available to users. For example, many cellular devices now incorporate personal digital assistant (PDA) features such as calendars, address books, task lists, etc. Moreover, such multi-function devices may also allow users to wirelessly send and receive electronic mail (email) messages and access the Internet via a cellular network and/or a wireless local area network (WLAN), for example.

[0003] Even so, as the functionality of cellular communications devices continues to increase, so too does the demand for smaller devices which are easier and more convenient for users to carry. One challenge this poses for cellular device manufacturers is designing antennas that provide desired operating characteristics within the relatively limited amount of space available for the antenna.

[0004] One exemplary cellular antenna structure is disclosed in U.S. Patent No. 6,897,817 to Jo et al. The antenna includes a conductive top plate formed in the shape of a spiral. In one embodiment a sidewall meanderline extends from an edge of the top plate in the direction of a ground plane. A shorting meanderline connects the top plate and the ground plane. A first region of the top plate overlies the ground plane. A second region of the top plate extends beyond the ground plane. Tuning is provided by adjusting the length and other dimensions of the meanderlines.

[0005] For internal antennas such as the one described above which are carried within the housing of a cellular device, it is typically difficult for such devices to comply with applicable specific absorption rate (SAR) and hearing aid compatibility (HAC) requirements due in part to the relatively close proximity of the antenna to the user's ear. As such, further improvements may be desirable to help achieve desired SAR and/or HAC requirements.

Brief Description of the Drawings

[0006] FIG. 1 is a perspective view of a mobile wireless communications device in accordance with the invention

next to a user wearing an electronic hearing aid.

[0007] FIG. 2 is a schematic front view of the PCB and director element of the mobile wireless communications device of FIG. 1.

5 [0008] FIG. 3 is a schematic rear view of the PCB and director element of the mobile wireless communications device of FIG. 1.

[0009] FIG. 4 is schematic side view of the PCB, director element, and housing of the mobile wireless communications device of FIG. 1.

[0010] FIG. 5 is a schematic side view of an alternative embodiment of the PCB, director element, and housing of the mobile wireless communications device of FIG. 1.

10 [0011] FIG. 6 is a schematic front view of an alternative embodiment of the PCB and director elements of the mobile wireless communications device of FIG. 1.

[0012] FIGS. 7 through 9 are two-dimensional beam pattern diagrams for a mobile wireless communications device antenna at three respective operating frequencies without an associated director element and with an associated director element in accordance with the invention.

20 [0013] FIG. 10 is a schematic block diagram of the mobile wireless communications device of FIG. 1 illustrating additional exemplary components thereof.

Detailed Description of the Preferred Embodiments

[0014] The present description is made with reference to the accompanying drawings, in which preferred embodiments are shown. However, many different embodiments may be used, and thus the description should not be construed as limited to the embodiments set forth herein. Rather, these embodiments are provided so that this disclosure will be thorough and complete. Like numbers refer to like elements throughout, and prime and multiple prime notation are used to indicate similar elements in alternative embodiments.

[0015] Generally speaking, a mobile wireless communications device is disclosed herein which may include a portable housing, a printed circuit board (PCB) carried by the portable housing, a wireless transceiver carried by the PCB, and an antenna connected to the transceiver and carried by the PCB. The mobile wireless communications device may further include at least one director element for directing a beam pattern of the antenna. More particularly, the at least one director element may include an electrically conductive main branch carried by the portable housing, and an electrically conductive connector portion extending between the main branch and the PCB. The director element(s) may advantageously be used to direct the beam pattern of the antenna to reduce interference with a hearing aid of a user, for example, to advantageously improve hearing aid compatibility of the mobile wireless communications device, for example.

[0016] The PCB may include a top portion and a bottom portion, and the antenna may be carried by the bottom portion of the PCB. Moreover, the PCB may have a gen-

erally rectangular shape with opposing sides and opposing ends, and the electrically conductive main branch may extend parallel with a side of the PCB. The at least one director element may also be a pair thereof, with a respective electrically conductive main branch of each director element extending parallel to a respective side of the PCB. Furthermore, the electrically conductive main branch may extend parallel with the rear surface of the PCB.

[0017] The electrically conductive main branch may be carried within the portable housing or externally of the portable housing. In addition, the PCB may include an antenna feed area connected to the antenna, and the electrically conductive connector portion may contact the PCB adjacent the antenna feed area. Also, the antenna may have an operating wavelength, and the electrically conductive main branch may have a length of about $\frac{1}{4}$ to $\frac{1}{2}$ of the operating wavelength, for example. The electrically conductive main branch may be an electrically conductive bar, for example. Moreover, the electrically conductive connector portion may extend transversely from a medial portion of the electrically conductive main branch. Additionally, the wireless transceiver may be a cellular transceiver, for example.

[0018] A method aspect is for improving hearing aid compatibility (HAC) of a mobile wireless communications device, such as the one discussed briefly above, for a user with an electronic hearing aid. The method may include positioning at least one director element for directing a beam pattern of the antenna to reduce interference with the hearing aid. The at least one director element may include an electrically conductive main branch carried by the portable housing, and an electrically conductive connector portion extending between the main branch and the PCB.

[0019] Referring initially to FIGS. 1 through 4, a mobile wireless communications device, such as a cellular telephone **20**, is for a user **21** wearing an electronic hearing aid **22** in an ear **23** of the user. The cellular telephone **20** illustratively includes a portable housing **24** and an audio output transducer **28** (e.g., a speaker) carried by the housing and accessible to the electronic hearing aid **22** of the user **21** adjacent the top of the housing as shown. An audio input transducer (i.e., microphone) is also carried by the housing **24** and accessible to a mouth **31** of the user **21** adjacent the bottom of the housing. Although described herein with reference to a cellular device, it should be noted that the present disclosure may be applicable to other wireless communications devices such as wireless LAN devices, etc.

[0020] Furthermore, an antenna **35** is illustratively positioned adjacent the bottom of the housing **24** so that the electronic hearing aid **22** of the user **21** is advantageously separated from the antenna when the cellular telephone **20** is held adjacent the user's ear **23**. Because of the increased separation thus achieved between the antenna **35** and the electronic hearing aid **22**, the cellular telephone **20** advantageously reduces undesired cou-

pling from the antenna to the electronic hearing aid without the need for special shielding arrangements. As a result, this configuration is beneficial from a hearing aid compatibility (HAC) standpoint. Moreover, this also helps reduce SAR, as will be appreciated by those skilled in the art.

[0021] The cellular telephone **20** further illustratively includes a printed circuit board (PCB) **37** carried by the housing **24**, and the antenna **35** and a wireless (e.g., cellular) transceiver **38** are carried by the PCB. Of course, these components may be carried on the back surface or in positions other than those shown in other embodiments.

[0022] The PCB **37** illustratively includes an antenna feed area **40** where the antenna **35** connects to the wireless transceiver **38**. The antenna **35** may include a plurality of conductive traces on the PCB **37**, for example, as will be appreciated by those skilled in the art. As noted above, the positioning of the antenna **35** adjacent a bottom of the housing **24** advantageously reduces coupling to the electronic hearing aid **22** of the user **21**, however the antenna may be located elsewhere in different embodiments. The cellular telephone **20** may further include other components connected to the PCB **37** such as a display, battery, keypad, processing circuitry, etc., as will be discussed further below.

[0023] The cellular telephone **20** further illustratively includes one or more director elements **30** for directing a beam pattern of the antenna **35**. More particularly, the director element **30** illustratively includes an electrically conductive main branch **32** carried by the housing **24**, and an electrically conductive connector portion **33** extending between the main branch and the PCB **37**. The director element **30** is advantageously used to direct the beam pattern of the antenna **35** to further reduce interference with the electronic hearing aid **22** of the user **21**, for example, to advantageously improve hearing aid compatibility of the cellular telephone **20**. That is, by directing the beam pattern of the antenna **35** such that the main lobe gain is directed away from the ear **23**, and thus the electronic hearing aid **22**, of the user **21**, this advantageously reduces the interference with the electronic hearing aid, as will be appreciated by those skilled in the art.

[0024] As seen in FIGS. 2 and 3, the PCB **37** illustratively has a generally rectangular shape with opposing sides **41 a**, **41 b** and opposing ends **42 a**, **42 b**, and the electrically conductive main branch **32** extends parallel with a rear surface of the PCB. The electrically conductive connector portion **33** extends transversely from a medial portion **45** of the electrically conductive main branch **32** and connects the main branch to a ground plane **46** on the back surface of the PCB **37**. While the electrically conductive connector portion **33** is shown as a relatively short and straight connector bar in the illustrated example, the connector portion may take various shapes, such as a sawtooth shape, etc. Moreover, the electrically conductive connector portion **33** may be a mechanical con-

nectors such as a spring connector, etc.

[0025] The electrically conductive main branch **32** is an electrically conductive bar in the illustrated example, although other shapes may be used in different embodiments. By way of example, the electrically conductive main branch **32** may include curved or sawtooth meanders, loops, or other features used to affect the electrical length of the main branch, as will be appreciated by those skilled in the art. The electrically conductive main branch **32** may have a width of about 5 to 7 mm, for example, although other widths may also be used depending upon the given implementation.

[0026] The length of the electrically conductive main branch **32** is preferably about $\frac{1}{4}$ to $\frac{1}{2}$ of the operating wavelength of the antenna **35**, for example, to provide desired beam steering for SAR reduction and HAC improvement, but here again other lengths may also be used. Moreover, positioning the electrically conductive connector portion **33** to contact the PCB **37** adjacent the antenna feed area **40** may also assist in this regard by providing greater influence over the direction of beam pattern of the antenna **35**.

[0027] By way of comparison, FIGS. 7 through 9 each illustrate a measured two-dimensional beam pattern **70**, **80**, **90** for the antenna **35** without an associated director element **30**, as well as beam patterns **71**, **81**, **91** for the antenna with two associated director elements **30**, respectively. More particularly, the two director elements **30** were positioned on the back side of the PCB **37** (i.e., similar to the embodiment illustrated in FIGS. 1-4 but with two spaced apart director elements instead of a single director element). The beam patterns **70**, **71** correspond to an operating frequency of 1850 MHz, the beam patterns **80**, **81** correspond to an operating frequency of 1880 MHz, and the beam patterns **90**, **91** correspond to an operating frequency of 1910 MHz.

[0028] In the present example, the electrically conductive main branch **32** is carried within the housing **24** on an inside sidewall thereof, as seen in FIG. 4. As such, in this embodiment rather than a bar the electrically conductive main branch **32** could be implemented by metalizing the sidewall of the housing **24**, for example. Moreover, an air gap **47** is shown between the PCB **37** and the electrically conductive main branch **32**, but in some embodiments this space may be filled with a solid dielectric, for example. The electrically conductive main branch **32** may also be partially or completely enclosed within the sidewall of the housing **24**.

[0029] Turning now additionally to FIG. 5, in an alternative embodiment the electrically conductive main branch **32'** may be carried externally of the portable housing **24'**, i.e., on an outside surface thereof, as shown. In another alternative embodiment, a pair of director elements **30a'**, **30b'** are included with respective electrically conductive main branches **32a'**, **32b'** extending parallel to a respective side **41a'**, **41b'** of the PCB **37** (FIG. 6).

[0030] A method aspect is for improving hearing aid compatibility (HAC) of a mobile wireless communications

device **20** for a user with an electronic hearing aid **22**. The method may include positioning at least one director element **30** for directing a beam pattern of the antenna **35** to reduce interference with the electronic hearing aid **22**. As noted above, the at least one director element **30** may include an electrically conductive main branch **32** carried by the portable housing **24**, and an electrically conductive connector portion **33** extending between the main branch and the PCB **37**.

[0031] Other exemplary components of a hand-held mobile wireless communications device **1000** are now described in the example below with reference to FIG. 10. The device **1000** illustratively includes a housing **1200**, a keypad **1400** and an output device **1600**. The output device shown is a display **1600**, which is preferably a full graphic LCD. Other types of output devices may alternatively be utilized. A processing device **1800** is contained within the housing **1200** and is coupled between the keypad **1400** and the display **1600**. The processing device **1800** controls the operation of the display **1600**, as well as the overall operation of the mobile device **1000**, in response to actuation of keys on the keypad **1400** by the user.

[0032] The housing **1200** may be elongated vertically, or may take on other sizes and shapes (including clamshell housing structures). The keypad may include a mode selection key, or other hardware or software for switching between text entry and telephony entry.

[0033] In addition to the processing device **1800**, other parts of the mobile device **1000** are shown schematically in FIG. 10. These include a communications subsystem **1001**; a short-range communications subsystem **1020**; the keypad **1400** and the display **1600**, along with other input/output devices **1060**, **1080**, **1100** and **1120**; as well as memory devices **1160**, **1180** and various other device subsystems **1201**. The mobile device **1000** is preferably a two-way RF communications device having voice and data communications capabilities. In addition, the mobile device **1000** preferably has the capability to communicate with other computer systems via the Internet.

[0034] Operating system software executed by the processing device **1800** is preferably stored in a persistent store, such as the flash memory **1160**, but may be stored in other types of memory devices, such as a read only memory (ROM) or similar storage element. In addition, system software, specific device applications, or parts thereof, may be temporarily loaded into a volatile store, such as the random access memory (RAM) **1180**. Communications signals received by the mobile device may also be stored in the RAM **1180**.

[0035] The processing device **1800**, in addition to its operating system functions, enables execution of software applications **1300A-1300N** on the device **1000**. A predetermined set of applications that control basic device operations, such as data and voice communications **1300A** and **1300B**, may be installed on the device **1000** during manufacture. In addition, a personal information manager (PIM) application may be installed during man-

ufacture. The PIM is preferably capable of organizing and managing data items, such as e-mail, calendar events, voice mails, appointments, and task items. The PIM application is also preferably capable of sending and receiving data items via a wireless network **1401**. Preferably, the PIM data items are seamlessly integrated, synchronized and updated via the wireless network **1401** with the device user's corresponding data items stored or associated with a host computer system.

[0036] Communication functions, including data and voice communications, are performed through the communications subsystem **1001**, and possibly through the short-range communications subsystem. The communications subsystem **1001** includes a receiver **1500**, a transmitter **1520**, and one or more antennas **1540** and **1560**. In addition, the communications subsystem **1001** also includes a processing module, such as a digital signal processor (DSP) **1580**, and local oscillators (LOs) **1601**. The specific design and implementation of the communications subsystem **1001** is dependent upon the communications network in which the mobile device **1000** is intended to operate. For example, a mobile device **1000** may include a communications subsystem **1001** designed to operate with the Mobitex™, Data TAC™ or General Packet Radio Service (GPRS) mobile data communications networks, and also designed to operate with any of a variety of voice communications networks, such as AMPS, TDMA, CDMA, PCS, GSM, etc. Other types of data and voice networks, both separate and integrated, may also be utilized with the mobile device **1000**.

[0037] Network access requirements vary depending upon the type of communication system. For example, in the Mobitex and DataTAC networks, mobile devices are registered on the network using a unique personal identification number or PIN associated with each device. In GPRS networks, however, network access is associated with a subscriber or user of a device. A GPRS device therefore requires a subscriber identity module, commonly referred to as a SIM card, in order to operate on a GPRS network.

[0038] When required network registration or activation procedures have been completed, the mobile device **1000** may send and receive communications signals over the communication network **1401**. Signals received from the communications network **1401** by the antenna **1540** are routed to the receiver **1500**, which provides for signal amplification, frequency down conversion, filtering, channel selection, etc., and may also provide analog to digital conversion. Analog-to-digital conversion of the received signal allows the DSP **1580** to perform more complex communications functions, such as demodulation and decoding. In a similar manner, signals to be transmitted to the network **1401** are processed (e.g. modulated and encoded) by the DSP **1580** and are then provided to the transmitter **1520** for digital to analog conversion, frequency up conversion, filtering, amplification and transmission to the communication network **1401** (or net-

works) via the antenna **1560**.

[0039] In addition to processing communications signals, the DSP **1580** provides for control of the receiver **1500** and the transmitter **1520**. For example, gains applied to communications signals in the receiver **1500** and transmitter **1520** may be adaptively controlled through automatic gain control algorithms implemented in the DSP **1580**.

[0040] In a data communications mode, a received signal, such as a text message or web page download, is processed by the communications subsystem **1001** and is input to the processing device **1800**. The received signal is then further processed by the processing device **1800** for an output to the display **1600**, or alternatively to some other auxiliary I/O device **1060**. A device user may also compose data items, such as e-mail messages, using the keypad **1400** and/or some other auxiliary I/O device **1060**, such as a touchpad, a rocker switch, a thumb-wheel, or some other type of input device. The composed data items may then be transmitted over the communications network **1401** via the communications subsystem **1001**.

[0041] In a voice communications mode, overall operation of the device is substantially similar to the data communications mode, except that received signals are output to a speaker **1100**, and signals for transmission are generated by a microphone **1120**. Alternative voice or audio I/O subsystems, such as a voice message recording subsystem, may also be implemented on the device **1000**. In addition, the display **1600** may also be utilized in voice communications mode, for example to display the identity of a calling party, the duration of a voice call, or other voice call related information.

[0042] The short-range communications subsystem enables communication between the mobile device **1000** and other proximate systems or devices, which need not necessarily be similar devices. For example, the short-range communications subsystem may include an infrared device and associated circuits and components, or a Bluetooth™ communications module to provide for communication with similarly-enabled systems and devices.

[0043] Many modifications and other embodiments will come to the mind of one skilled in the art having the benefit of the teachings presented in the foregoing descriptions and the associated drawings. Therefore, it is understood that various modifications and embodiments are intended to be included within the scope of the appended claims.

Claims

1. A mobile wireless communications device comprising:
 - a portable housing;
 - a printed circuit board (PCB) carried by said port-

- able housing;
 a wireless transceiver carried by said PCB;
 an antenna connected to said transceiver and carried by said PCB; and
 at least one director element for directing a beam pattern of said antenna and comprising
- an electrically conductive main branch carried by said portable housing, and
 an electrically conductive connector portion extending between said main branch and said PCB.
2. The mobile wireless communications device of Claim 1 wherein said PCB has a generally rectangular shape with opposing sides and opposing ends; and wherein said electrically conductive main branch extends parallel with a side of said PCB.
 3. The mobile wireless communications device of Claim 1 wherein said PCB comprises a top portion and a bottom portion; and wherein said antenna is carried by the bottom portion of said PCB.
 4. The mobile wireless communications device of Claim 1 wherein said PCB has a generally rectangular shape with opposing sides and opposing ends; wherein said at least one director element comprises a pair thereof; and wherein a respective electrically conductive main branch of each director elements extends parallel to a respective side of said PCB.
 5. The mobile wireless communications device of Claim 1 wherein said PCB has a generally rectangular shape with opposing front and rear surfaces; and wherein said electrically conductive main branch extends parallel with the rear surface of said PCB.
 6. The mobile wireless communications device of Claim 1 wherein said electrically conductive main branch is carried within said portable housing.
 7. The mobile wireless communications device of Claim 1 wherein said electrically conductive main branch is carried externally of said portable housing.
 8. The mobile wireless communications device of Claim 1 wherein said PCB comprises an antenna feed area connected to said antenna; and wherein said electrically conductive connector portion contacts said PCB adjacent said antenna feed area.
 9. The mobile wireless communications device of Claim 1 wherein said antenna has an operating wavelength; and wherein said electrically conductive main branch has a length of about $\frac{1}{4}$ to $\frac{1}{2}$ the operating wavelength.
10. The mobile wireless communications device of Claim 1 wherein said electrically conductive main branch comprises an electrically conductive bar.
 11. The mobile wireless communications device of Claim 1 wherein said electrically conductive connector portion extends transversely from a medial portion of said electrically conductive main branch.
 12. The mobile wireless communications device of Claim 1 wherein said wireless transceiver comprises a cellular transceiver.
 13. The mobile wireless communications device of Claim 1 further comprising a ground plane carried by said PCB; and wherein said electrically conductive connector portion extends between said electrically conductive main branch and said ground plane.
 14. A method for improving hearing aid compatibility (HAC) of a mobile wireless communications device for a user with an electronic hearing aid and comprising a portable housing, a printed circuit board (PCB) carried by the portable housing, a wireless transceiver carried by the PCB, an antenna connected to the transceiver and carried by the PCB, the method comprising:
 - positioning at least one director element for directing a beam pattern of the antenna to reduce interference with the electronic hearing aid, the at least one director element comprising an electrically conductive main branch carried by the portable housing and an electrically conductive connector portion extending between the main branch and the PCB.
 15. The method of to Claim 14 wherein the PCB has a generally rectangular shape with opposing sides and opposing ends; and wherein the electrically conductive main branch extends parallel with a side of the PCB.
 16. The method of Claim 14 wherein the PCB comprises a top portion and a bottom portion; and wherein the antenna is carried by the bottom portion of the PCB.
 17. The method of Claim 14 wherein the PCB has a generally rectangular shape with opposing front and rear surfaces; and wherein the electrically conductive main branch extends parallel with the rear surface of the PCB.
 18. The method of Claim 14 wherein the PCB comprises an antenna feed area connected to the antenna; and wherein the electrically conductive connector portion contacts the PCB adjacent the antenna feed area.

- 19. The method of Claim 14 wherein the antenna has an operating wavelength; and wherein the electrically conductive main branch has a length of about ¼ to ½ the operating wavelength.
- 20. The method of Claim 14 wherein the electrically conductive connector portion extends transversely from a medial portion of the electrically conductive main branch.

Amended claims in accordance with Rule 86(2) EPC.

1. A mobile wireless communications device (20) comprising:

- a portable housing (24);
- a printed circuit board PCB (37) carried by said portable housing having a top portion (42a) and a bottom portion (42b);
- a wireless transceiver (38) carried by said PCB; and
- an antenna (35) connected to said transceiver and carried by the bottom portion of said PCB and within the housing; and
- at least one director element (30) for directing a beam pattern of said antenna, said at least one director element comprising
- an electrically conductive main branch (32) carried by said portable housing, and
- an electrically conductive connector portion (33) extending between said main branch and said PCB.

2. The mobile wireless communications device (20) of Claim 1 wherein said PCB (37) has a generally rectangular shape with opposing sides (41a, 41b) and opposing ends (42a, 42b); and wherein said electrically conductive main branch (32) extends parallel with a side of said PCB.

3. The mobile wireless communications device (20) of Claim 1 wherein said PCB (37) has a generally rectangular shape with opposing sides (41a, 41b) and opposing ends (42a, 42b); wherein said at least one director element (30) comprises a pair thereof; and wherein a respective electrically conductive main branch (32) of each director elements extends parallel to a respective side of said PCB (37).

4. The mobile wireless communications device (20) of Claim 1 wherein said PCB (37) has a generally rectangular shape with opposing front and rear surfaces; and wherein said electrically conductive main branch extends parallel with the rear surface of said PCB.

5. The mobile wireless communications device (20)

of Claim 1 wherein said electrically conductive main branch (32) is carried within said portable housing (24).

6. The mobile wireless communications device (20) of Claim 1 wherein said electrically conductive main branch (32) is carried externally of said portable housing (24).

7. The mobile wireless communications device (20) of Claim 1 wherein said PCB (37) comprises an antenna feed area (40) connected to said antenna (35); and wherein said electrically conductive connector portion (33) contacts said PCB adjacent said antenna feed area.

8. The mobile wireless communications device (20) of Claim 1 wherein said antenna (35) has an operating wavelength; and wherein said electrically conductive main branch (32) has a length of about ¼ to ½ the operating wavelength.

9. The mobile wireless communications device (20) of Claim 1 wherein said electrically conductive main branch (32) comprises an electrically conductive bar.

10. The mobile wireless communications device (20) of Claim 1 wherein said electrically conductive connector portion (33) extends transversely from a medial portion of said electrically conductive main branch (32).

11. The mobile wireless communications device (20) of Claim 1 wherein said wireless transceiver (38) comprises a cellular transceiver.

12. The mobile wireless communications device (20) of Claim 1 further comprising a ground plane carried by said PCB (37); and wherein said electrically conductive connector portion (33) extends between said electrically conductive main branch (32) and said ground plane.

13. A method for improving hearing aid compatibility (HAC) of a mobile wireless communications device (20) for a user (21) with an electronic hearing aid (22) and comprising a portable housing, a printed circuit board PCB (37) carried by the portable housing and having a top portion (42a) and a bottom portion (42b), a wireless transceiver (38) carried by the PCB, an antenna (35) connected to the transceiver and carried by the bottom portion of the PCB and within the housing, the method comprising:

positioning at least one director element (30) for directing a beam pattern of the antenna to reduce interference with the electronic hearing aid, the at least one director element comprising

an electrically conductive main branch (32) carried by the portable housing and an electrically conductive connector portion (33) extending between the main branch and the PCB.

5

14. The method of to Claim 13 wherein the PCB (37) has a generally rectangular shape with opposing sides (41a, 41b) and opposing ends (42a, 42b); and wherein the electrically conductive main branch (32) extends parallel with a side of the PCB.

10

15. The method of Claim 13 wherein the PCB (37) has a generally rectangular shape with opposing front and rear surfaces; and wherein the electrically conductive main branch (32) extends parallel with the rear surface of the PCB.

15

16. The method of Claim 13 wherein the PCB (37) comprises an antenna feed area (40) connected to the antenna (35); and wherein the electrically conductive connector portion (33) contacts the PCB adjacent the antenna feed area.

20

17. The method of Claim 13 wherein the antenna (35) has an operating wavelength; and wherein the electrically conductive main branch (32) has a length of about $\frac{1}{4}$ to $\frac{1}{2}$ the operating wavelength.

25

18. The method of Claim 13 wherein the electrically conductive connector portion (33) extends transversely from a medial portion of the electrically conductive main branch (32).

30

35

40

45

50

55

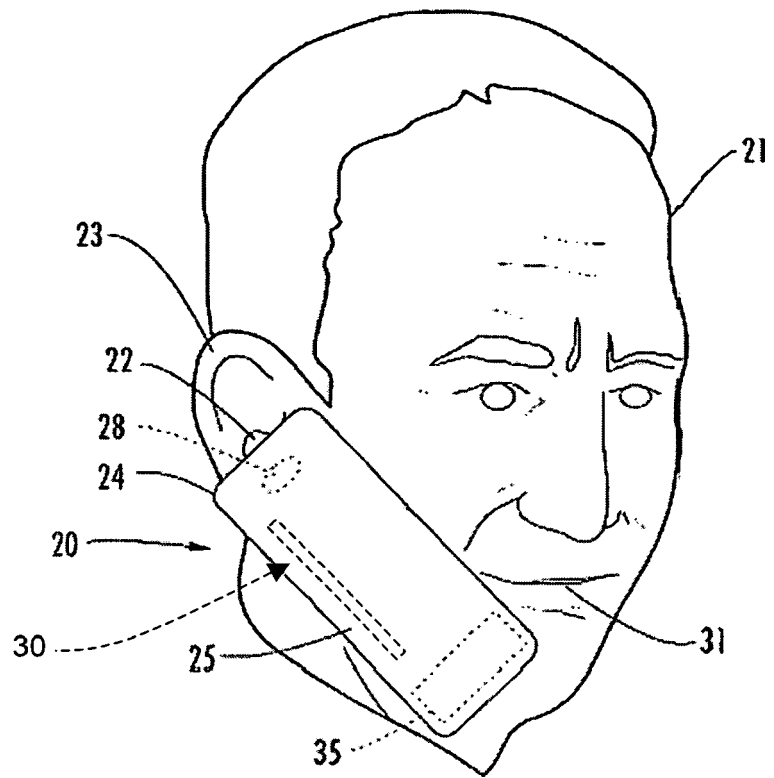

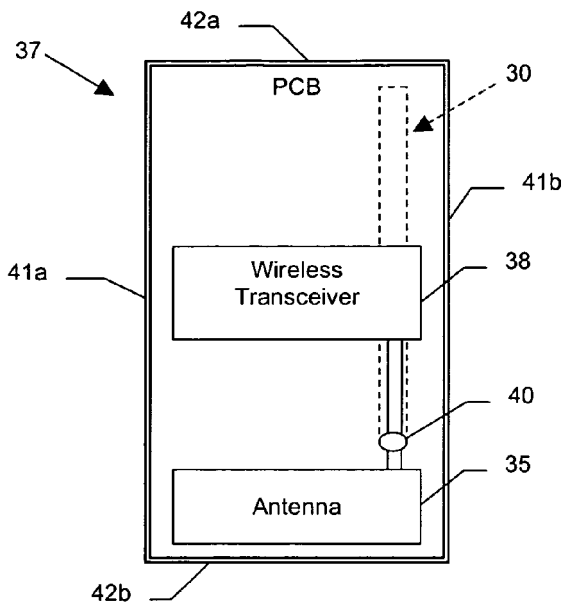

FIG. 2

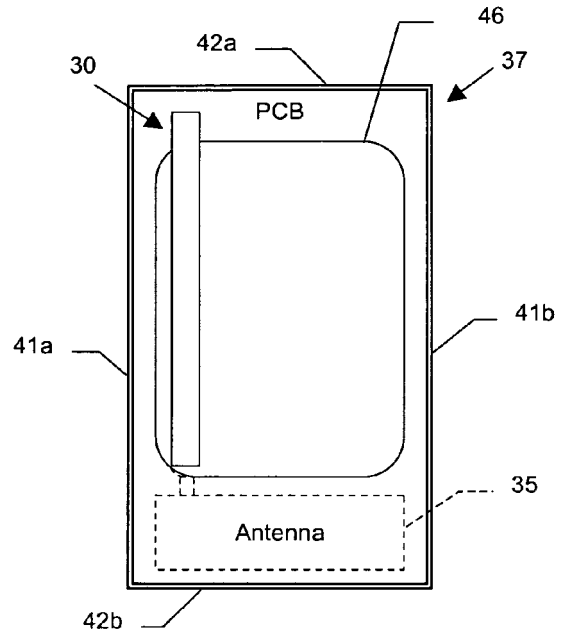

FIG. 3

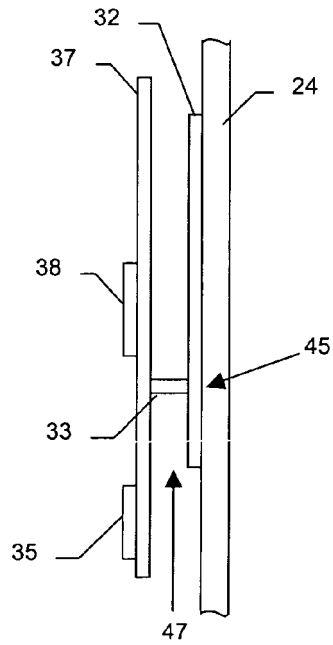

FIG. 4

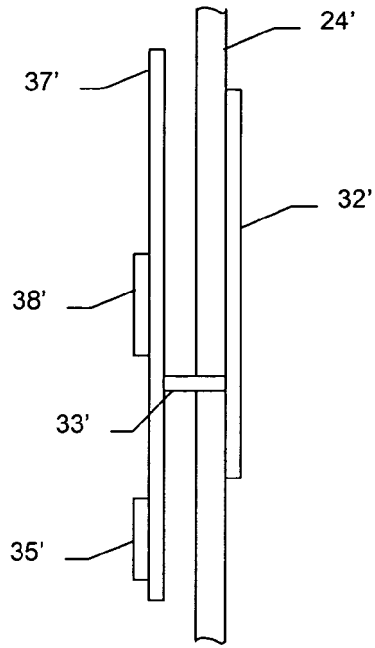

FIG. 5

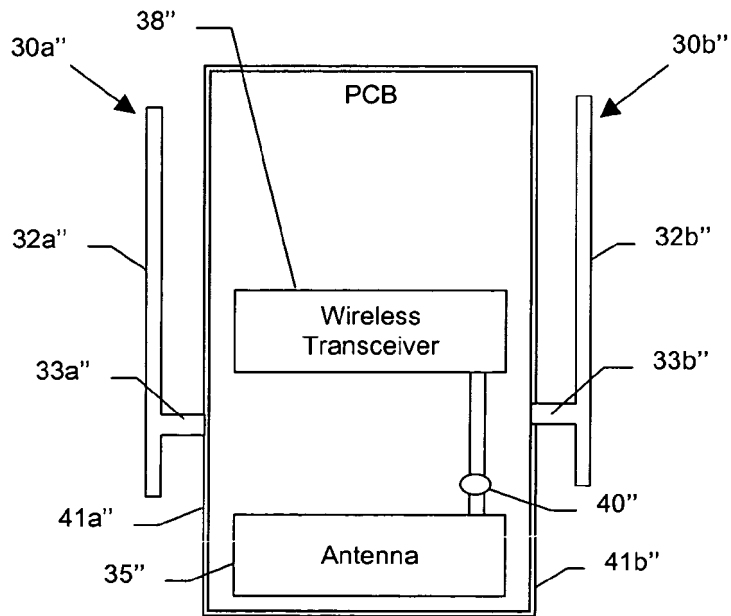

FIG. 6

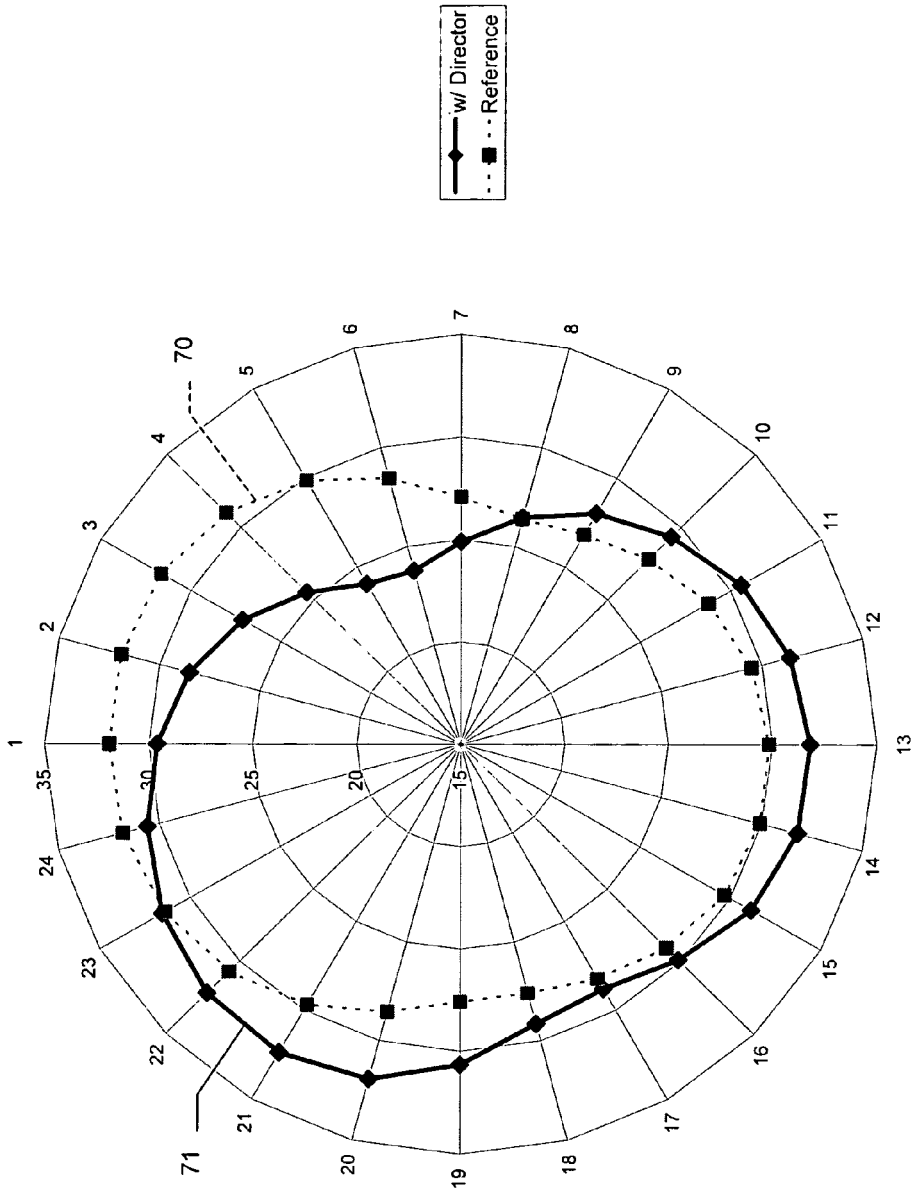

FIG. 7

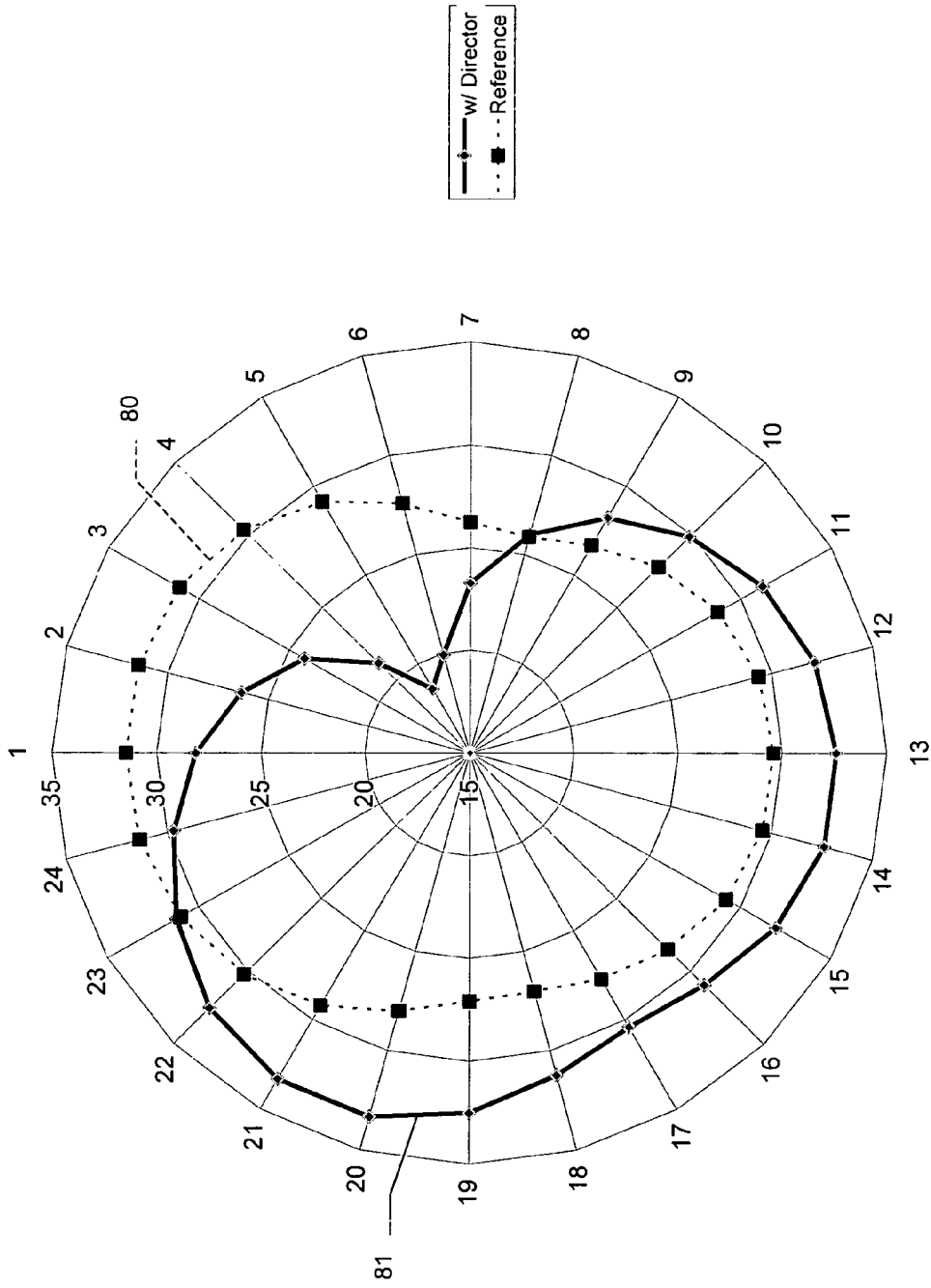

FIG. 8

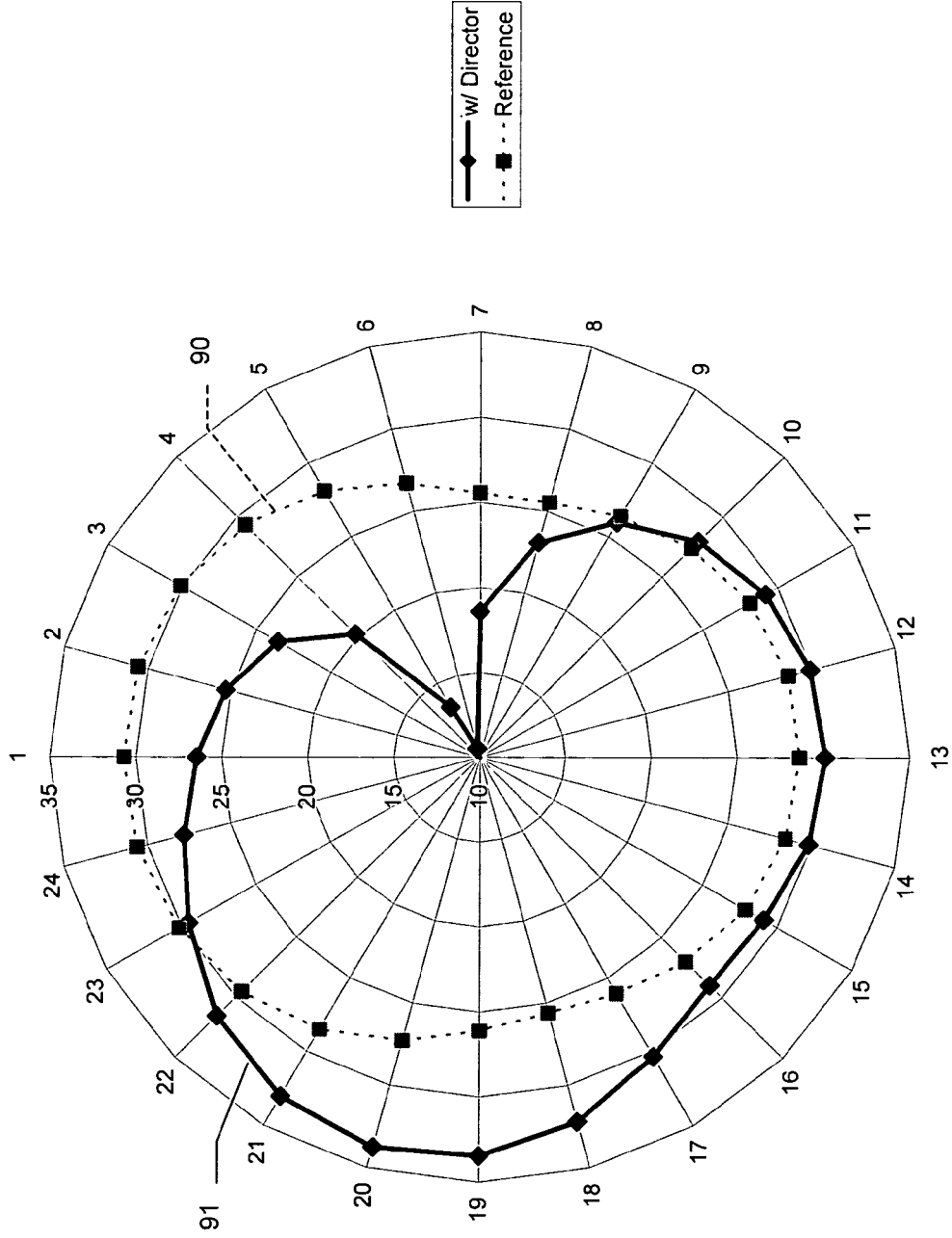

FIG. 9

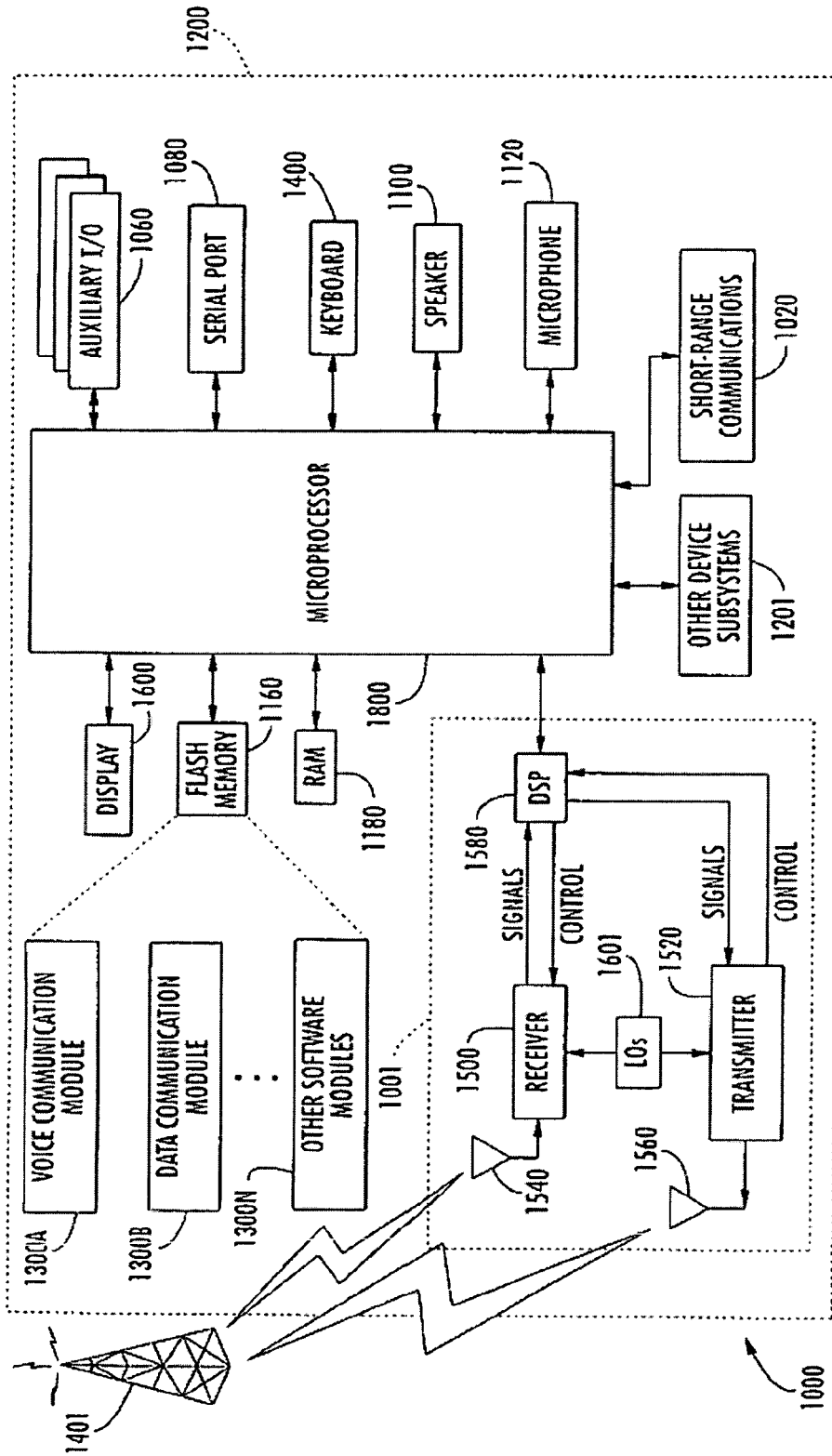

FIG. 10



DOCUMENTS CONSIDERED TO BE RELEVANT			
Category	Citation of document with indication, where appropriate, of relevant passages	Relevant to claim	CLASSIFICATION OF THE APPLICATION (IPC)
X	EP 1 271 688 A (KABUSHIKI KAISHA TOSHIBA) 2 January 2003 (2003-01-02)	1,2,4-6, 8-10, 12-15, 17-19	INV. H01Q1/24 H01Q19/28 H01Q19/22
Y	* paragraph [0006] - paragraph [0063]; figures 1,2,7,8,12C * -----	3,7,16	
X	DE 102 48 756 A1 (SIEMENS AG) 18 March 2004 (2004-03-18) * paragraph [0031] - paragraph [0033]; figures 1,2,5,6 * -----	1,2,4-6, 8,11-15, 17,18,20	
X	EP 1 353 401 A (FILTRONIC LK OY) 15 October 2003 (2003-10-15) * paragraph [0010] - paragraph [0011]; figures 2-4 * -----	1,2,4-6, 8-15, 17-20	
Y	US 2004/046694 A1 (CHIANG BING ET AL) 11 March 2004 (2004-03-11) * figure 1C * -----	3,16	TECHNICAL FIELDS SEARCHED (IPC)
Y	WO 2005/004277 A (SK TELECOM CO., LTD; SKYCROSS, INC) 13 January 2005 (2005-01-13) * abstract * -----	7	H01Q
A	US 2003/151557 A1 (JOHNSON GREGORY F) 14 August 2003 (2003-08-14) * abstract * -----	14	
The present search report has been drawn up for all claims			
Place of search Munich		Date of completion of the search 14 June 2006	Examiner Kaleve, A
CATEGORY OF CITED DOCUMENTS X : particularly relevant if taken alone Y : particularly relevant if combined with another document of the same category A : technological background O : non-written disclosure P : intermediate document		T : theory or principle underlying the invention E : earlier patent document, but published on, or after the filing date D : document cited in the application L : document cited for other reasons & : member of the same patent family, corresponding document	

2
EPO FORM 1503 03.02 (P04C01)

**ANNEX TO THE EUROPEAN SEARCH REPORT
ON EUROPEAN PATENT APPLICATION NO.**

EP 06 25 0180

This annex lists the patent family members relating to the patent documents cited in the above-mentioned European search report. The members are as contained in the European Patent Office EDP file on the European Patent Office is in no way liable for these particulars which are merely given for the purpose of information.

14-06-2006

Patent document cited in search report		Publication date	Patent family member(s)	Publication date
EP 1271688	A	02-01-2003	CN 1392673 A	22-01-2003
			DE 60202243 D1	20-01-2005
			DE 60202243 T2	22-12-2005
			JP 2003069442 A	07-03-2003
			US 2002193138 A1	19-12-2002

DE 10248756	A1	18-03-2004	NONE	

EP 1353401	A	15-10-2003	CN 1450686 A	22-10-2003
			FI 20020674 A	10-10-2003
			US 2003189523 A1	09-10-2003

US 2004046694	A1	11-03-2004	US 2005156797 A1	21-07-2005

WO 2005004277	A	13-01-2005	CN 1577958 A	09-02-2005
			JP 2005027278 A	27-01-2005

US 2003151557	A1	14-08-2003	AU 2003211001 A1	04-09-2003
			CN 1647314 A	27-07-2005
			EP 1476919 A1	17-11-2004
			JP 2005518125 T	16-06-2005
			WO 03069729 A1	21-08-2003

REFERENCES CITED IN THE DESCRIPTION

This list of references cited by the applicant is for the reader's convenience only. It does not form part of the European patent document. Even though great care has been taken in compiling the references, errors or omissions cannot be excluded and the EPO disclaims all liability in this regard.

Patent documents cited in the description

- US 6897817 B, Jo [0004]