

(19) World Intellectual Property  
Organization  
International Bureau



(43) International Publication Date  
8 July 2004 (08.07.2004)

PCT

(10) International Publication Number  
**WO 2004/057307 A1**

(51) International Patent Classification<sup>7</sup>: G01N 1/31, 1/30

80526 (US). **KEY, Marc** [US/US]; 290 Saddle Lane, Ojai, CA 93023 (US). **LATHROP, Bob** [US/US]; 1667 Glenrock Court, San Jose, CA 95124 (US). **WELCHER, Rosanne** [US/US]; 1175 Church Street, Ventura, CA 93001 (US).

(21) International Application Number:

PCT/DK2003/000877

(22) International Filing Date:

15 December 2003 (15.12.2003)

(74) Agent: **LARSEN, Anna**; Dakocytomation Denmark A/S, Produktionsvej 42, DK-2600 Glostrup (DK).

(25) Filing Language:

English

(26) Publication Language:

English

(30) Priority Data:

60/435,601 20 December 2002 (20.12.2002) US

(81) Designated States (*national*): AE, AG, AL, AM, AT (utility model), AT, AU, AZ, BA, BB, BG, BR, BY, BZ, CA, CH, CN, CO, CR, CU, CZ (utility model), CZ, DE (utility model), DE, DK (utility model), DK, DM, DZ, EC, EE (utility model), EE, EG, ES, FI (utility model), FI, GB, GD, GE, GH, GM, HR, HU, ID, IL, IN, IS, JP, KE, KG, KP, KR, KZ, LC, LK, LR, LS, LT, LU, LV, MA, MD, MG, MK, MN, MW, MX, MZ, NI, NO, NZ, OM, PG, PH, PL, PT, RO, RU, SC, SD, SE, SG, SK (utility model), SK, SL, SY, TJ, TM, TN, TR, TT, TZ, UA, UG, US, UZ, VC, VN, YU, ZA, ZM, ZW.

(71) Applicant (*for all designated States except US*): **DAKOCYTOMATION DENMARK A/S** [DK/DK]; Produktionsvej 42, DK-2600 Glostrup (DK).

(72) Inventors; and

(75) Inventors/Applicants (*for US only*): **FAVUZZI, John** [US/US]; 5086 San Bernardo Place, Santa Barbara, CA 93111 (US). **GUGGENHEIMER, Benno** [US/US]; 608 Park Street, Fort Collins, CO 80521 (US). **RAU, Jeff** [US/US]; 2960 W. Stuart St., Apt. 303, Fort Collins, CO

(84) Designated States (*regional*): ARIPO utility model (BW), ARIPO patent (BW), ARIPO utility model (GH), ARIPO patent (GH), ARIPO utility model (GM), ARIPO patent (GM), ARIPO utility model (KE), ARIPO patent (KE), ARIPO utility model (LS), ARIPO patent (LS), ARIPO

[Continued on next page]

(54) Title: METHOD AND APPARATUS FOR PRETREATMENT OF BIOLOGICAL SAMPLES

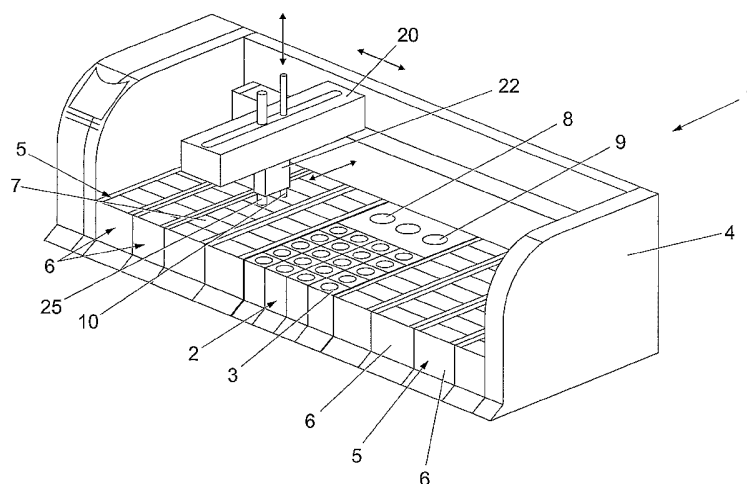

(57) Abstract: The present invention concerns a method and an apparatus for automatic staining at least one biological sample, such as a tissue, accommodated on a carrier, e.g. a microscope slide (7) by applying a predetermined amount of reagents in a sequence according to a staining protocol, wherein at least one carrier is provided in a carrier rack assembly, wherein the carrier rack assembly comprises means for pretreatment of the biological sample on a carrier after the carrier is provided in the carrier rack assembly, said means for pretreatment of biological samples includes a tank (10) which is provided in the carrier rack assembly (6), a carrier rack (61); and means for pivoting the carriers (7) provided in the carrier rack (61) to a vertical position and means for immersing the vertical carrier (7v) into the tank (10). By pivoting the carriers (7) from a horizontal to a vertical position, an automated method and apparatus for carrying out the pretreatment in the automated staining apparatus is provided. This pivoting of carriers (7) ensures an appropriate orientation of the carriers for both the pretreatment and the staining processes.

WO 2004/057307 A1



utility model (MW), ARIPO patent (MW), ARIPO utility model (MZ), ARIPO patent (MZ), ARIPO utility model (SD), ARIPO patent (SD), ARIPO utility model (SL), ARIPO patent (SL), ARIPO utility model (SZ), ARIPO patent (SZ), ARIPO utility model (TZ), ARIPO patent (TZ), ARIPO utility model (UG), ARIPO patent (UG), ARIPO utility model (ZM), ARIPO patent (ZM), ARIPO utility model (ZW), ARIPO patent (ZW), Eurasian patent (AM, AZ, BY, KG, KZ, MD, RU, TJ, TM), European patent (AT, BE, BG, CH, CY, CZ, DE, DK, EE, ES, FI, FR, GB, GR, HU, IE, IT, LU, MC, NL, PT, RO, SE, SI,

SK, TR), OAPI patent (BF, BJ, CF, CG, CI, CM, GA, GN, GQ, GW, ML, MR, NE, SN, TD, TG).

**Published:**

- *with international search report*
- *before the expiration of the time limit for amending the claims and to be republished in the event of receipt of amendments*

*For two-letter codes and other abbreviations, refer to the "Guidance Notes on Codes and Abbreviations" appearing at the beginning of each regular issue of the PCT Gazette.*

## METHOD AND APPARATUS FOR PRETREATMENT OF BIOLOGICAL SAMPLES

The present invention relates to a method and an apparatus for automatic staining at least one biological sample accommodated on a carrier, such as a slide by applying a predetermined amount of reagents in a sequence according to a staining protocol, wherein at least one carrier is provided in a carrier rack assembly.

This application relates to the field of sample processing systems and methods of processing biological samples. The present invention may be directed to the automated processing, treatment, or even staining of samples arranged on carriers, such as microscope slides, and in some embodiments, directed to the continuous or batch processing of samples and carriers, as well as washing elements of a sampling system. Embodiments may further relate to control systems for sample processing and data acquisition, data maintenance, and data retrieval for sample processing. Applications to which the present invention may especially relate include immunohistochemistry, in-situ hybridization, fluorescent in-situ hybridization, special staining, and microarrays, as well as potentially other chemical and biological applications.

Sample processing in immunohistochemical (IHC) applications and in other chemical and biological analyses may require one or a number of various processing sequences or protocols as part of an analysis of one or more samples. The sample processing sequences or protocols may be defined by the individual or organization requesting an analysis, such as a pathologist or histologist of a hospital, and may be further defined by the dictates of a particular analysis to be performed.

In preparation for sample analysis, a biological sample may be acquired by known sample acquisition techniques and may comprise, for example in IHC applications, tissues generally or even in some applications one or a plurality of isolated cells, such as in microarray samples, and may be presented on a sample carrier such as a microscope slide. Furthermore, the sample may be presented on the carrier variously and potentially in some form of preservation. As one example, a sample such as a

layer or slice of skin may be preserved in formaldehyde and presented on a carrier with one or more paraffin or other chemical layers overlying the sample.

Immunologic applications, for example, may require processing sequences or protocols that comprise steps such as deparaffinization, target retrieval, and staining, especially for in-situ hybridization (ISH) techniques. Previously, in some applications, these steps may have been performed manually, potentially creating a time-intensive protocol and necessitating personnel to be actively involved in the sample processing. Attempts have been made to automate sample processing to address the need for expedient sample processing and a less manually burdensome operation. However, such previous efforts may have not fully addressed the needs for an automated sample processing system. Previous efforts to automate sample processing may be deficient in several aspects that prevent more robust automated sample processing, such as: the lack of sufficient computer control and monitoring of sample processing; the lack of information sharing for processing protocol and processing status, especially for individual samples; the lack of diagnostic capabilities; and the lack of real-time or adaptive capabilities for multiple sample batch processing.

Past efforts at automated sample processing for samples presented on carriers such as slides, such as US Patent No. 6,352,861 and US Patent No. 5,839,091, have not afforded the various advantages and other combinations of features as presented herein.

The biological samples, such as tissue samples, must be prepared before the staining can be performed. The tissue slides are subjected to a pretreatment process depending on the type of staining process is to be performed on the tissue. This pretreatment could include a deparaffinization or a target retrieval. The preparation of the tissues on the slides is often carried out manually in the laboratory before they are loaded into the automatic staining instrument. This pretreatment includes immersing the slide in a buffer or other types of processing liquid for a predetermined amount of time and temperature.

However, this manual preparation is cumbersome and the pretreatment may be insufficient, since it is critical that the amount of time and the temperature of the liquid must be observed very precisely in order to achieve the correct pretreatment  
5 result.

On this background, it is an object of the invention to provide an automatic pretreatment of the biological samples on carriers such as slides, in the automatic staining apparatus so that the entire processing of the biological samples may be  
10 performed in a single automatic apparatus.

The invention consists of a method of treatment of at least one biological sample accommodated on a carrier in an automated staining apparatus, said method comprising the steps of: providing at least one carrier carrying a biological sample in  
15 a predetermined carrier location, said carrier being provided in a substantially horizontal position; pivoting said at least one carrier to a substantially vertical position; immersing said substantially vertically oriented carrier into a tank for a predetermined processing time. Preferably, the carrier location is a carrier rack, wherein a plurality of carriers may be provided in a carrier holder, wherein the  
20 carriers are individually pivotable.

The object is also achieved by an apparatus for automatic staining at least one biological sample accommodated on a carrier by applying a predetermined amount of reagents in a sequence according to a staining protocol, wherein at least one carrier is  
25 provided in a carrier rack assembly, wherein the carrier rack assembly comprises means for pretreatment of the biological sample on a carrier after the carrier is provided in the carrier rack assembly, said means for pretreatment of biological samples includes a tank which is provided in the carrier rack assembly; a carrier holder; and means for pivoting the carriers provided in the carrier holder to a vertical  
30 position and means for immersing the vertical carrier into the tank.

By pivoting the carriers from a horizontal to a vertical position, an automated method and apparatus for carrying out the pretreatment in the automated staining apparatus is provided. This pivoting of carriers ensures an appropriate orientation of the carriers for both the pretreatment and the staining processes.

5

By the present invention, the preparation of the biological samples on the carriers is integrated in the automatic staining apparatus, so that a biological sample once it is accommodated on a carrier can be loaded into a staining apparatus wherein both the pretreatment and the staining protocols may be performed automatically in the apparatus.

10

Preferably, a selected processing liquid is supplied from at least one supply tank into a tank. The steps of filling and draining the tank are controlled by the control system of the apparatus, which ensures that the carriers are subjected to the appropriate pretreatment steps according to information concerning this in the staining protocol.

15

Preferably, the liquid is transferred from a supply tank to a transfer tank and onwards to a tank. Accordingly, the apparatus preferably comprises pneumatic means for transferring processing liquid from a supply tank to a transfer tank and from the transfer tank to the tank and draining liquid from the tank to the transfer tank and from said transfer tank to a waste collection tank. An advantage achieved by transferring the liquids by a pneumatic system is that the at least one transfer tank, the supply tank and the waste tank may be positioned outside the apparatus, hereby allowing for an increased capacity as there are no dimensional constraints on the tank sizes. Furthermore, by this embodiment of the invention it is possible to subject the immersed carrier to a series of fluids which are sequentially filled and drained from the tank, since the system may easily be adapted to contain several supply tanks containing different liquids and similarly also several waste tanks so that it is possible to sort the waste.

20

25

30

Preferably, said tank is provided with a heating member for heating the processing liquid contained in the tank, and the heating member may advantageously be capable

of heating the tank content to an elevated temperature of at least 60, more preferably at least 95°C, and even more preferably at least 115°C. Hereby, the temperature of the fluid in the tank may be heated up to 120°C or even as high as 150°C and kept at this temperature for between 10 to 20 minutes without any sign of boiling. In an  
5 embodiment, the heating member is adapted to heat the fluid to a temperature of 95°C for 40 minutes or more for performing a target retrieval process.

According to an embodiment of the invention, the at least one vertical carrier is immersed into the tank by lowering the carrier holder and immersing the carrier into  
10 the tank after at least one carrier is pivoted to a vertical position. Hereby, a compact tank arrangement and carrier holder lay out is achieved.

The method of treatment of tissue could be a pretreatment of the tissue sample. However, by the invention it is realised that other types of treatment may be  
15 performed on the tissue sample on the carrier in a vertical position, such as rinsing the carriers. Other processes that may be performed by an apparatus according to the invention include deparaffinization or target retrieval processes of the tissue sample.

According to the invention, the tank is an elongated tank having an upper opening  
20 slot allowing the vertically oriented carriers to be inserted into the container for treatment. Hereby, the volume of the tank and thereby the amount of processing fluid needed is minimized.

Preferably, the apparatus includes means for recycling the drained liquid for re-use in  
25 a later pre-treatment process of carriers. Hereby, the amount of fluids used for the operation of the apparatus, i.e. the pretreatment and the rinsing of the tissue carriers, may be minimized resulting in an easier waste handling and a reduction in costs.

In the preferred embodiment of the invention, the carrier rack assembly is provided  
30 in a drawer assembly, wherein the rack may be retracted from the apparatus for loading and unloading of carriers. The drawer assembly cooperates with a tank in the drawer receiving means of the apparatus, said tank being capable of simultaneous

processing of a plurality of carriers accommodated in a plurality of carrier holders in the carrier rack assembly. The drawer assembly provides the apparatus with a great flexibility in use, as carriers may be loaded or unloaded from one drawer while the carriers in the other drawers may be processed independent thereof. Furthermore, the use of drawers makes it easy to operate the automatic staining apparatus. The tanks for each of the drawers may preferably be connected to common supply and waste tanks which advantageously may be arranged outside the apparatus.

The invention is described with reference to a preferred embodiment with reference to the drawings, in which:

- Fig. 1 is a schematic perspective view of a staining apparatus according to the preferred embodiment of the invention;
- Fig. 2 is a top view of the work area in the staining apparatus shown in fig. 1;
- 15 Fig. 3 is a schematic front view of a drawer assembly including a slide rack assembly and a tank in an apparatus according to the invention;
- Fig. 4 is a perspective view of a drawer assembly in a closed position;
- Fig. 5 is the drawer assembly of fig. 4 in an open position;
- Fig. 6 is a perspective top view of a slide rack according to a preferred embodiment of the invention;
- 20 Fig. 7 is a detailed view of the slide rack holder and the tank arranged in a drawer assembly;
- Fig. 8 is a perspective view of a tank according to the preferred embodiment of the invention;
- 25 Fig. 9 is a front view of the tank of fig. 8; and
- Fig. 10 is a fluidic diagram of the handling of processing liquid for the tank.

Figure 1 shows one schematic embodiment of a sample processing system 101 in accordance with the present invention. Cabinet sections 4 form outer portions of the system and serve to address general structural considerations of the system (a top cabinet section is not shown in Figure 1). The sample processing system may comprise a plurality of drawers 6 used for the handling and processing of samples



and sample carriers such as slides, potentially microscope slides. Other sample carriers may be accommodated consistent with the present invention. Each drawer may be configured to accommodate sample carrier retainment assemblies, such as slide retainment assemblies, carrier racks, modules, or magazines.

5

One embodiment of a sample carrier retainment assembly may comprise a slide retainment assembly 6 as shown in Figure 7. The slide retainment assembly may comprise a slide rack, module, or magazines. Slide retainment assembly 6 is configured to accommodate a plurality of slides in at least one configuration in  
10 corresponding sample carrier retention devices. The sample carrier retainment assemblies, are utilized in the processing of samples as further described below. It should be further noted that the sample carrier retainment assembly can be removably configured with the drawers, and may be stackable or nested within other retainment assemblies.

15

In preferred embodiments, slides are configurable in both vertical and horizontal positions as required for the pretreatment and staining process, as shown in Figures 3 and 6. This allows for the automation of the pretreatment and staining of slides in various manners, including pretreatment and staining as accepted in conventional  
20 manual laboratory methods. The slides are initially loaded into the carrier retention assemblies, such as slide racks, and drawers in the horizontal position. The slides may be horizontally supported by adjustable carrier supports (shown in Figure 7). If pretreatment is required, such as deparaffinization, the system rotates the slide into the vertical position and lowers these samples into a dip processing tank, further  
25 described below, filled with the required fluids. In some embodiments, the slide rack is lowered to affect lowering of the slides (see Figure 3 and Figure 7). To perform the staining process on the slides, as described below, the System rotates the slide to the horizontal position and a syringe or probe applies fluid to the sample. Each slide can be rotated independently allowing for the independent processing of different  
30 samples with different requirements.

The sample processing system may automate processing steps of samples such as histological tissue sections or cell preparations presented on slides by pre-treatment processing, such as deparaffinization. The System provides onboard pretreatment of the slides. Examples of two types of pretreatment that are usually performed are -  
5 but not limited to - deparaffinization and target retrieval. In some embodiments, these processes must be performed with the slides in a vertical orientation, immersed in tanks of various fluids. Deparaffinization involves immersing the slides sequentially in a series of fluids for short periods of time (potentially for about 5 or 10 minutes). The process is intended to first remove from the sample the paraffin in  
10 which it was mounted or otherwise presented, remove the paraffin solvent, and then slowly rehydrate the sample. Target retrieval, and in some embodiments epitope unmasking, involves immersing the slides in a processing tank of heated buffer, and in some embodiments, immersing for about 20 minutes, and then allowing the slides to cool for about 20 minutes. Temperature in preferred embodiments is maintained  
15 at about 95 °C. In target retrieval, a marker or other identifier is used to mark a sample portion of interest, such as a cell or structure thereof.

The system automates, and in some embodiments mimics or otherwise corresponds to the procedure and physical attributes of the supplies used manually to perform  
20 these same pre-treatment processes. Accordingly, a processing tank 101 may be provided (as best shown in Figures 3, 7 and 8). In some embodiments, components of each processing tank 101, as shown in Figures 4 and 5, are configured within a drawer 100. In some preferred embodiments, the fluids volume needed to perform pre-treatment processes are maintained but instead of the slide orientation with each  
25 other being face-to-face, as in conventional systems, they are side-to-side, although other slide configurations are not disclaimed. The processing tanks provide even distribution of fluids across the face of the slide.

In some embodiments, the processing tanks have the ability to heat the slides. This  
30 heat is applied evenly across the face of each individual slide by a thermal element/device. The precision and physical application of the heat can result in standardization and repeatability of process steps. Filling and heating tasks are

performed by a computer controlled scheduler, as further described below. Fluid volume may be adjusted to account for the presence or absence of any number of slides.

5 A preferred embodiment of a staining apparatus 1 according to the invention is shown in figures 1 and 2. The staining apparatus 1 comprises a rectangular frame 4 surrounding a reagent station 2 comprising an array of reagent bottle compartments wherein each compartment a reagent vial 3 is placed, and a first and second slide sections 5 wherein a number of separate rack assemblies 6 is placed, and where each  
10 rack assembly 6 accommodates a number of microscope slides 7 mounted side by side in the rack assembly 6. In the embodiment shown, each rack may hold up to 8 slides, but the rack may be designed to hold any suitable number of slides. With eight racks arranged side by side, the shown embodiments may hold up to 64 slides 7 each having a sample, e.g. a tissue mounted on the upper side of the slide, so that reagent  
15 may be applied from above to the sample on each slide.

A robot arm 20 for moving a probe 10 in X and Y (as well as Z) direction as indicated by the arrows X and Y is arranged above the frame 4 of the staining apparatus. The robot arm 20 may therefore position the probe 10 above all reagent  
20 vials 3 as well as above all the microscope slides 7, and may further operate the probe 10 to aspirate portions of reagent contained in any of the vials 3, to transfer the portion of reagent and apply it to any of the slides 7 in order to provide a selected staining or treatment of the sample on each slide 7. By use of suitable control means e.g. a computer (not shown) having the appropriate software and input data for the  
25 purpose, this staining apparatus 1 is able to automatically staining or treating samples requiring different staining or treatment reagents and processes.

As shown in fig. 1, the probe 10 is accommodated in a robotic head 22 and is manipulated by the robot arm 20. The probe 10 is raised to an upper position (in a Z  
30 direction) where it is clear of the vials 3 underneath the probe 10, but the robot comprises means in the robotic head 22 for lowering the probe 10 in order to dip the probe tip into the content of a selected reagent vial 3 and to aspirate a selected

amount of reagent for the selected staining or treatment process. The robotic head 22 is also provided with a CCD camera 25 pointing downwards. The camera is utilised to determine status information of the slides and the reagent bottles and other features of the apparatus in the work area, for example reading a code provided on a reagent container to determine the reagent type and the reagent location within the system. The camera may also determine status of the tissue sample carriers, for example the location of a particular slide, informational indicia, such as a code, that indicate information about the tissue sample presented on the slide or the processing protocol to be performed.

10

The staining apparatus 1 of the present embodiment further comprises a probe washing station 8 and a reagent mixer 9, and the robot arm 20 is furthermore arranged to transfer the probe to the washing station 8 as well as to the reagent mixer 9.

15

The slides 7 in the slide rack assembly 6 are loaded and unloaded in a horizontal position when the slide rack assembly 6 is in an upper position, as shown in fig. 3. The slide rack assembly 6 is arranged in a slide elevator 63 and the slide holder 62 is adapted to pivot the slide 7 between a horizontal position to a vertical position 7v, when the slide rack 6 is in its upper position. The slide rack assembly 6 including the slide rack elevator 63 is arranged as a moving part 100a of a drawer assembly 100. In a corresponding stationary part 100b of the drawer assembly 100, a tank 101 is provided.

25

The apparatus preferably comprises eight drawer assemblies, as shown in figure 1. However, it is realised that any other number may also be provided depending on the design preferences. Each drawer assembly 100 includes a drawer slide, a slide elevator 63, a slide rack assembly 6 including slide temperature control members 64, a tank 101, a drip tray 65 for collecting staining fluids and control means including indicators for various user information and process surveillance purposes.

30

The slide rack assembly 6 is shown in fig. 6. The slide rack assembly 6 includes a slide rack 61 preferably with a capacity of eight slides 7 in individual slide receiving compartments 68, as shown in fig. 6. In connection with each compartment 68, a slide holder 62 is provided. The slide holders 62 include pivoting means including slide clips 69 which are pivotable between a horizontal slide position and a vertical slide position and activation means 67. The slides 7, 7v are individually pivotable in their slide holders 62, as the slide holder clips 69 may be pivoted by a pushing of a nesting tab 67, of which two are provided, one for pivoting from a horizontal to a vertical position and one for returning the slide from a vertical to a horizontal position.

The slide rack is in an upper position when the drawer 100 is loaded with one or more slides 7 and also during the staining process. After the slides 7 have been loaded, the slides 7 may be pivoted to a vertical position 7v and then the slide rack 6 is lowered by the slide elevator 63, such that the vertically disposed slides 7v are immersed into the underlying tank 101. The drawer assembly is also shown in the figures 4, 5 and 7. The slide elevator 63 may be adapted to agitate the slides 7v while they are immersed in the tank fluid.

The tank 101 is filled with a predetermined amount of a processing fluid from a transfer tank 110 (see fig. 10). The relevant processing fluid has prior to that been transferred from a supply tank 111 to the transfer tank 110 via pneumatic pressure means. By using a transfer tank 110 and controlling the fluid transfer by a pneumatic system including a vacuum pump 113, the pumping may be carried out without fluids coming into contact with pumping components. This is advantageous since the risk of residues of fluids in the components is hereby minimized.

A total of eight drawers are preferably provided. Accordingly, this means that eight tanks are also provided in the apparatus. Each tank 101 accommodates up to eight immersed slides 7v at the time. A primary function of the tank is to heat the fluid in the tank up from ambient temperature to a predetermined temperature, in a certain amount of time, e.g. 15 minutes and maintain the predetermined temperature, e.g. up

to about 120°C without any sign of boiling for a pretreatment processing time, e.g. 10 to 20 minutes after the slides have been lowered into the tank. Typically the preferred temperature is in the interval from about 40°C to about 120°C, as determined by the requested treatment. Very often the preferred temperature is in the interval from 80°C to 100°C, and more preferable from 95°C to 98°C. For some special treatments the preferred interval can be from 110°C to 130°C and even up to about 150°C.

After this process time is passed, the heat is turned off and the slides 7v are removed by raising the slide rack assembly 6 and thereby lifting the vertical slides 7v out of the tank 101. The tank 101 may be used for deparaffinization, re-hydration as well as heat induced target retrieval. These processes are performed onboard the apparatus with the slides in a vertical orientation, immersed in individual tanks that can be filled with and emptied of various required reagents. For the target retrieval process, the fluid level in the tank may raise onto the label on the slide. The heating member may be adapted to heat up and maintain a temperature of approx. 95°C for a period of up to 40 to 60 minutes. The pretreatment process carried out in the tank, may involve immersing the slides in a series of fluids for short periods of time, e.g. 5 to 10 minutes. The process of deparaffinization is intended to first remove from the tissue sample the paraffin in which it was mounted, then remove the paraffin solvent, and then through a series of reagents progressively re-hydrate the sample.

As shown in e.g. figures 8 and 9, the tank 101 is elongated with an opening slot 102 through which the slides 7v may be inserted. This results in a relative small tank volume, which in turn allows for relatively rapid heating of the fluid in the tank and/or relatively low power consumption for heating up and maintaining the temperature of the fluid in the tank. The tank 101 is filled and drained via a fluid connection tube 103 and the heating member 104 is preferably located in the lower section of the tank. The tank 101 is moreover provided with insulating sidewall members on both sides to accelerate the heating thereby decreasing the heating times. The tank 101 is also provided with sensor means (not shown) for registering the fluid

level in the tank and a sensor for registering the temperature of the fluid, and feeding these data to the control system of the apparatus.

5 The pretreatment fluids or reagents may be stored in a number of individual containers, where some containers store fluids that are dedicated for deparaffinization, some for target retrieval and containers with 100% alcohol, distilled water and buffers. The containers are advantageously provided with different volumes corresponding to the required amounts of the specific fluids for the performance of the pretreatment processes on the apparatus.

10

The fluid transfer between the supply containers 111 and the tanks 101 are via a transfer tank 110, as shown in fig. 10. The fluid transfer is accomplished through positive and negative air pressure applied to the transfer tank 110. Preferably two separate, dedicated transfer tanks (not shown) are provided, one for aqueous solutions and a second for organic solutions. Similarly, for emptying the tanks, the waste fluid is transferred via the transfer tank 110 to the waste containers 112. Preferably dedicated waste tanks are provided, e.g. one for hazardous waste fluids and one for non-hazardous waste fluids.

20 Fluids may be transferred in both directions between any container and any tank. The operational sequence of the fluid transfers is determined by the control system of the apparatus. The deparaffinization reagents may be reused and periodically cycled from clean to dirty. Used dirty deparaffinization fluids and tank rinse fluids may be discarded by the user or by the control system as hazardous waste. Target retrieval buffer and water are labelled "single use" fluids in the control system and transferred to waste after use.

30 Preferably, the method according to the invention may include temporary storage of at least one biological sample on a carrier in an appropriate liquid in the tank, e.g. after finishing the requested treatment until the biological sample on the carrier can be removed for further off-instrument processing. Typically, this use of the tank is

specifically advantageous in relation to an overnight staining, e.g. completed in the middle of the night.

5 Above, the apparatus and the method according to the invention are described according to some preferred explanatory embodiments. However, it is realised by the invention that many other variations and equivalents of the method and the apparatus may be carried out without departing from the scope of the invention as specified in the accompanying claims.



## PATENT CLAIMS:

1. A method of treatment of at least one biological sample accommodated on a carrier (7) in an automated staining apparatus, said method comprising the steps of:

5

providing at least one carrier (7) carrying a biological sample in a predetermined carrier location, said carrier (7) being provided in a substantially horizontal position;

pivoting said at least one carrier (7) to a substantially vertical position;

10 immersing said substantially vertically oriented carrier (7) into a tank for a predetermined processing time.

2. A method according to claim 1, whereby said carrier location is a carrier rack, wherein a plurality of carriers (7) may be provided in a carrier rack assembly (6),

15 wherein the carriers (7) are individually pivotable.

3. A method according to claim 1 or 2, including the step of supplying a selected processing liquid from at least one supply tank into a tank.

20 4. A method according to any of claims 1 to 3, including the steps of filling and draining the tank (101).

5. A method according to claim 4, whereby liquid is transferred from a supply tank to a transfer tank and onwards to a tank (101).

25

6. A method according to any of claims 1 to 5, including the step of subjecting the immersed carrier (7) to a series of fluids which are sequentially filled and drained from the tank (101).

30 7. A method according to any of claims 1 to 6, including the step of heating the liquid contained in the tank (101) to a predetermined temperature, preferably to an

elevated temperature of at least 60°C, more preferably at least 95°C, and even more preferably at least 115°C.

8. A method according to any of claims 1 to 7, including the step of inserting the at  
5 least one vertical carrier (7v) into the tank (101) by lowering the carrier rack and  
thereby immersing the at least one vertically disposed carrier (7v) into the tank (101).

9. A method according to any of claims 1 to 8, whereby said method of treatment of  
biological sample is a pretreatment of the biological sample.

10

10. A method according to any of claims 1 to 9, whereby the biological sample is  
tissue and said method of treatment of tissue is a deparaffinization treatment of the  
tissue sample.

15 11. A method according to any of claims 1 to 10, whereby said method of treatment  
sample of biological is a target retrieval processing of the biological sample.

12. A method according to any of claims 1 to 11, whereby said method comprises  
short term storage of the samples on the carriers (7v) in the vertical position lowered  
20 into a liquid in the tank (101).

13. An apparatus for automatic staining at least one biological sample accommodated  
on a carrier (7) by applying a predetermined amount of reagents in a sequence  
according to a staining protocol, wherein at least one carrier (7) is provided in a  
25 carrier rack assembly (6),

characterised in that

the carrier rack assembly (6) comprises

means for pretreatment of the biological sample on a carrier (7) after the carrier (7) is  
provided in the carrier rack assembly (6), said means for pretreatment of biological

30 samples includes a tank (101), which is provided in the carrier rack assembly (6),  
a carrier rack (61); and

means for pivoting the carriers (7) provided in the carrier rack (61) to a vertical position and means for immersing the vertical carrier (7v) into the tank (101).

14. An apparatus according to claim 13, wherein said means for pretreatment of carriers (7) include means for lowering the vertically disposed carriers (7v) of the carrier rack (61) into the tank (101).

15. An apparatus according to claim 13 or 14, wherein the tank (101) is an elongated tank having an upper opening slot allowing the vertically oriented carriers (7v) to be inserted into the container for treatment.

16. An apparatus according to any of claims 13 to 15, wherein said tank (101) is provided with a heating member for heating the processing liquid contained in the tank (101).

15

17. An apparatus according to claim 16, wherein the heating member is capable of heating the tank (101) content to an elevated temperature of at least 60°C, more preferably at least 95°C, and even more preferably at least 115°C.

18. An apparatus according to any of claims 13 to 16, wherein the apparatus comprises pneumatic means for transferring processing liquid from a supply tank (111) to a transfer tank (110) and from the transfer tank (110) to the tank (101) and draining liquid from the tank to the transfer tank and from said transfer tank to a waste collection tank (112).

25

19. An apparatus according to any of claims 13 to 18, wherein said apparatus includes means for recycling the drained liquid for re-use in a later pre-treatment process of carriers.

20. An apparatus according to any of claims 13 to 18, wherein the carrier rack assembly is provided in a drawer assembly which may be retracted from the apparatus for loading and unloading of carriers (7).

30

21. An apparatus according to claim 20, wherein the drawer assembly cooperates with a tank (101) in the drawer receiving means of the apparatus, said tank (101) being capable of simultaneous processing of a plurality of carriers (7) accommodated in a plurality of carrier holders in the carrier rack assembly (6).  
5

22. An apparatus according to claim 21, wherein a plurality of drawer assemblies are provided in the apparatus, each cooperating with a tank (101) and at least one transfer tank (110) and supply (111) and waste tanks (112).  
10

23. An apparatus according to claim 22, wherein fluid transfer between tank (101) and supply or waste tanks (111, 112) are via the at least one transfer tank (110), and that said transfer tank (110) is provided with pneumatic pressure control, including means for applying positive respective negative air pressure to the transfer tank (110).  
15

24. An apparatus according to any of claims 20 to 23, wherein the carriers (7) when accommodated in the carrier holders (62) are individually pivotable, and that the carrier rack assembly (6) is provided with pivoting means that may be activated by a robotic head (22), carrying out the staining processes according to the staining protocol.  
20

1/8

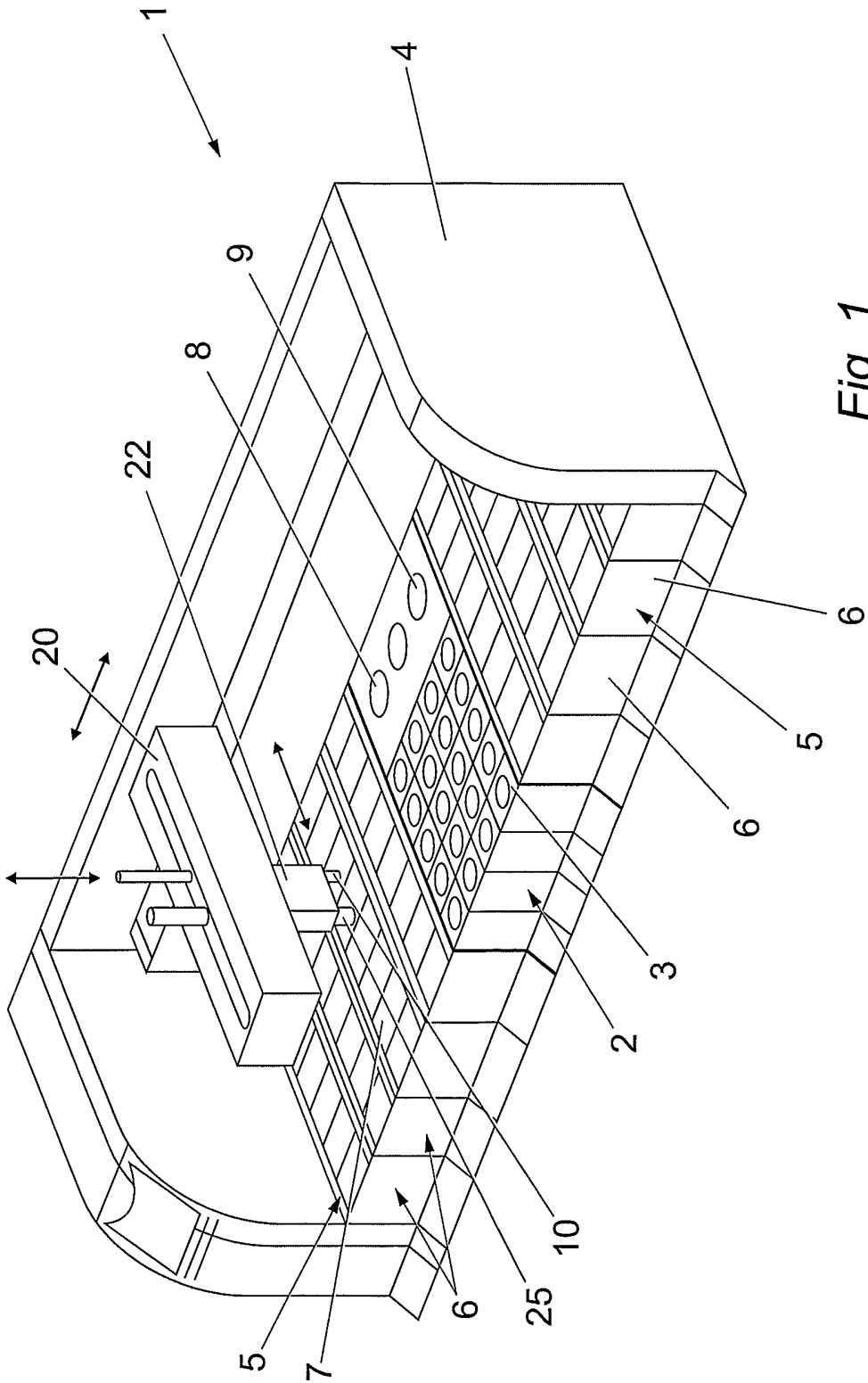

Fig. 1

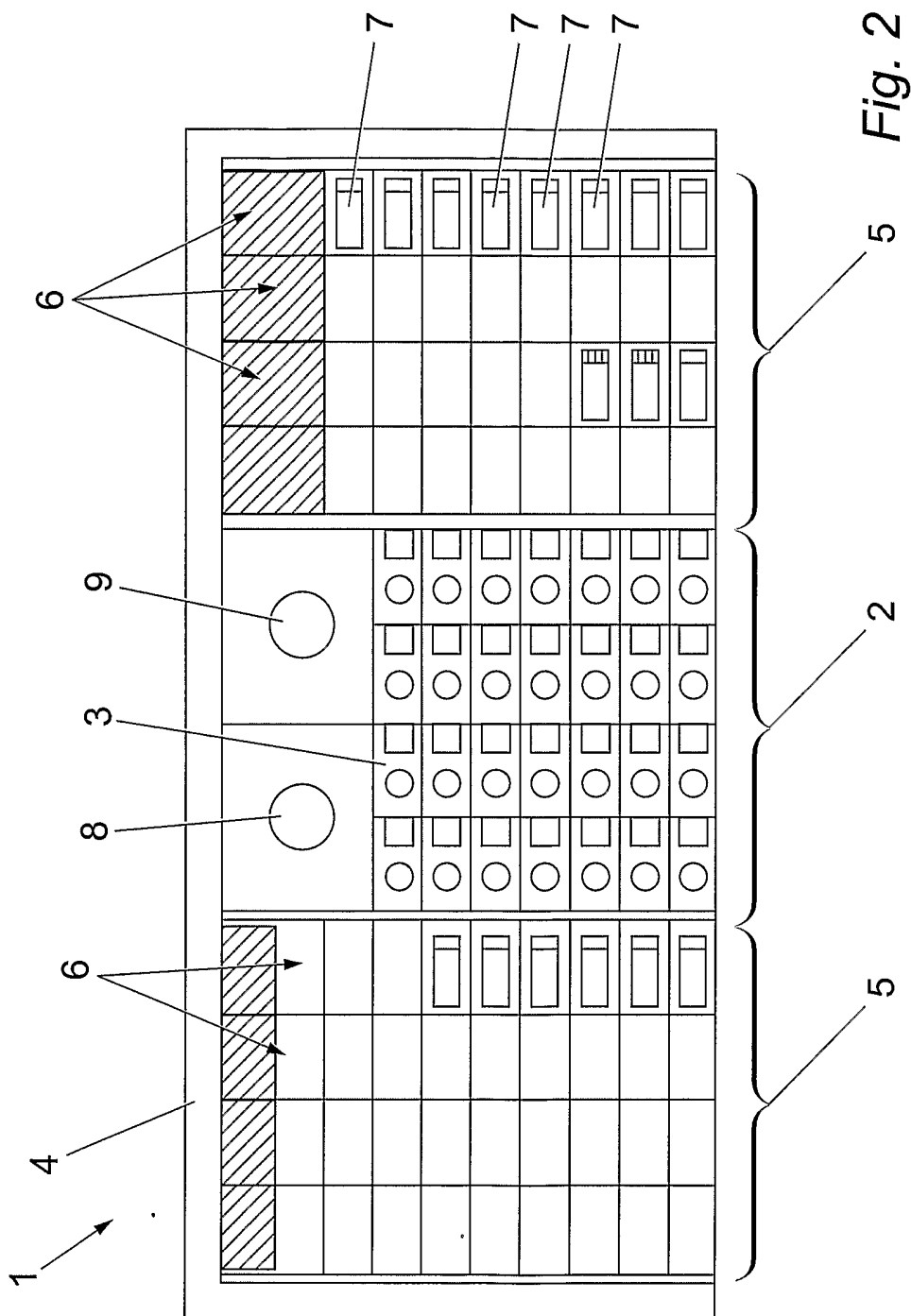

Fig. 2

3 / 8

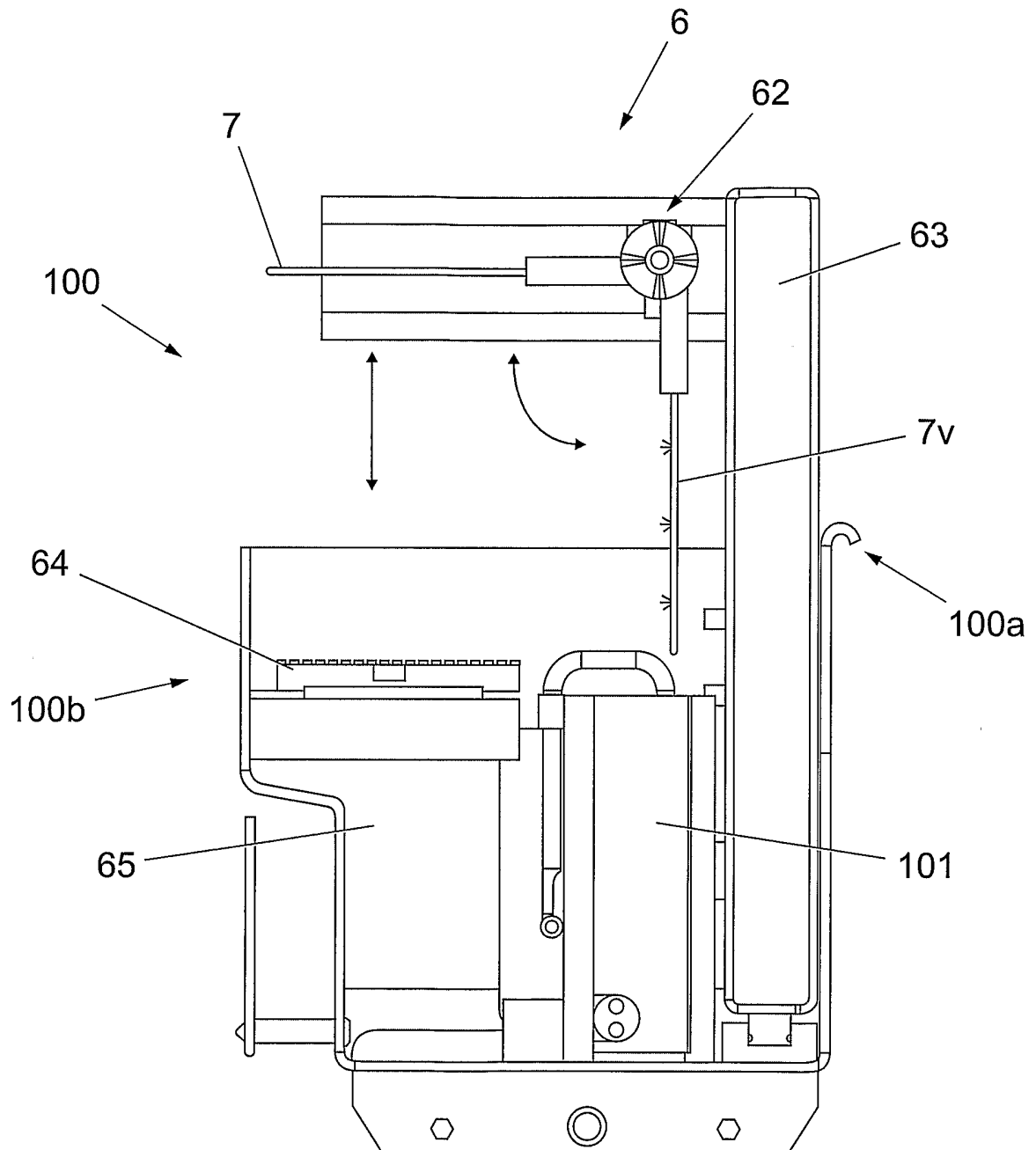

Fig. 3

4 / 8

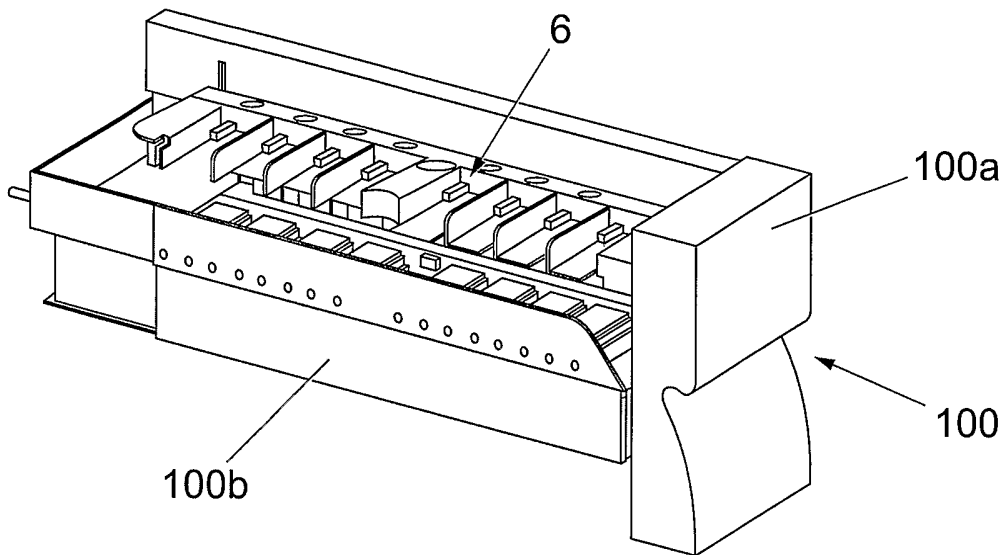

Fig. 4

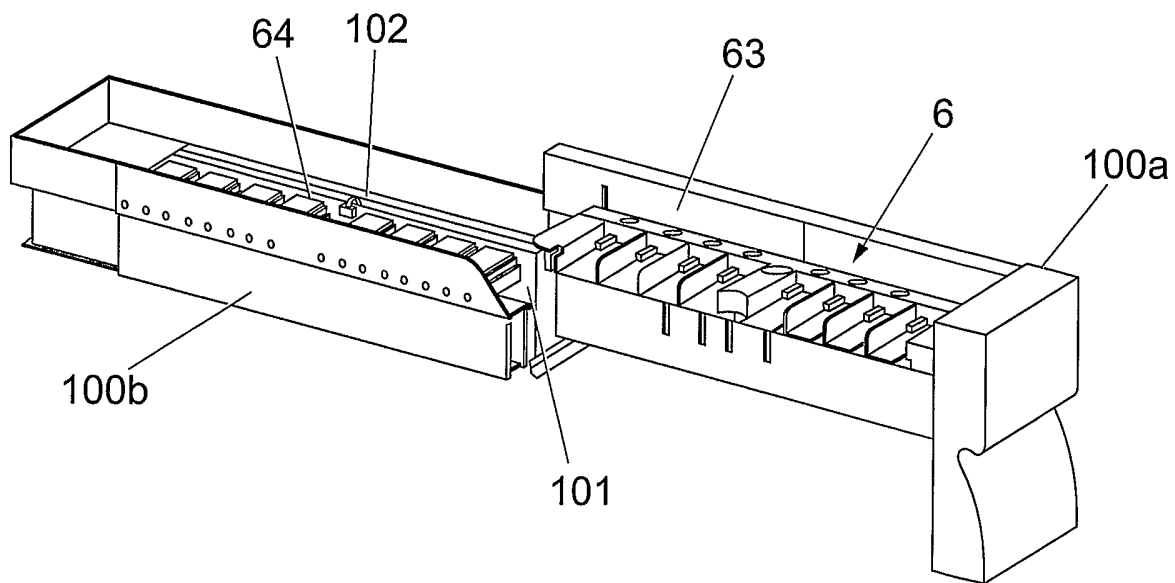

Fig. 5



5 / 8

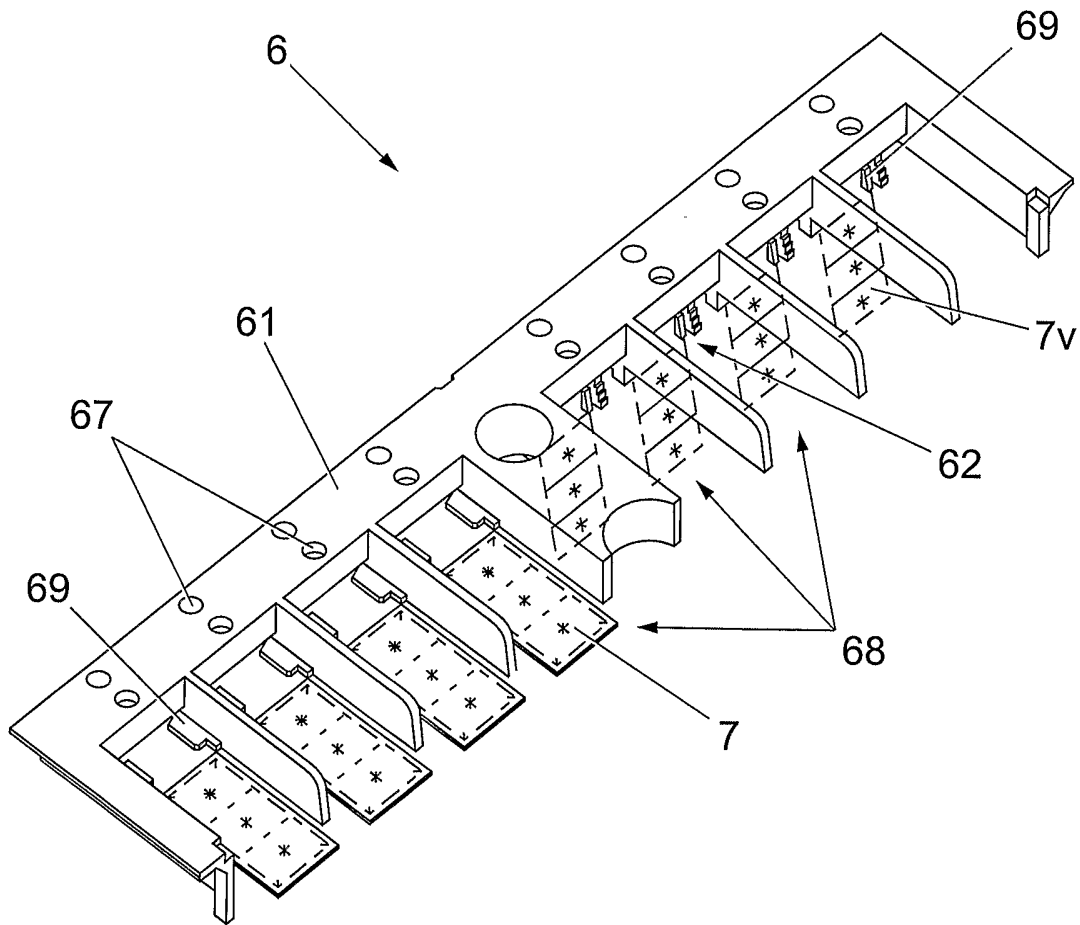

Fig. 6

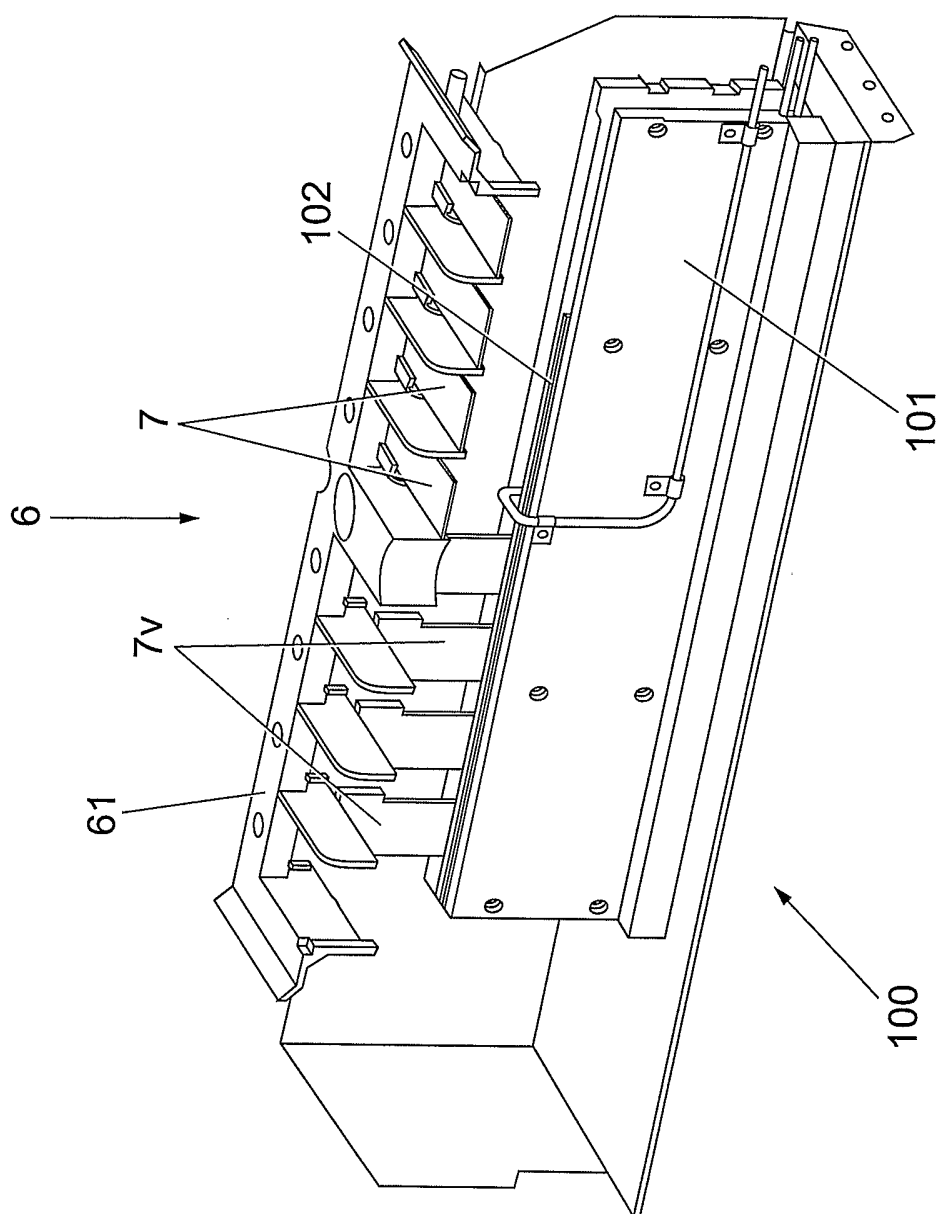
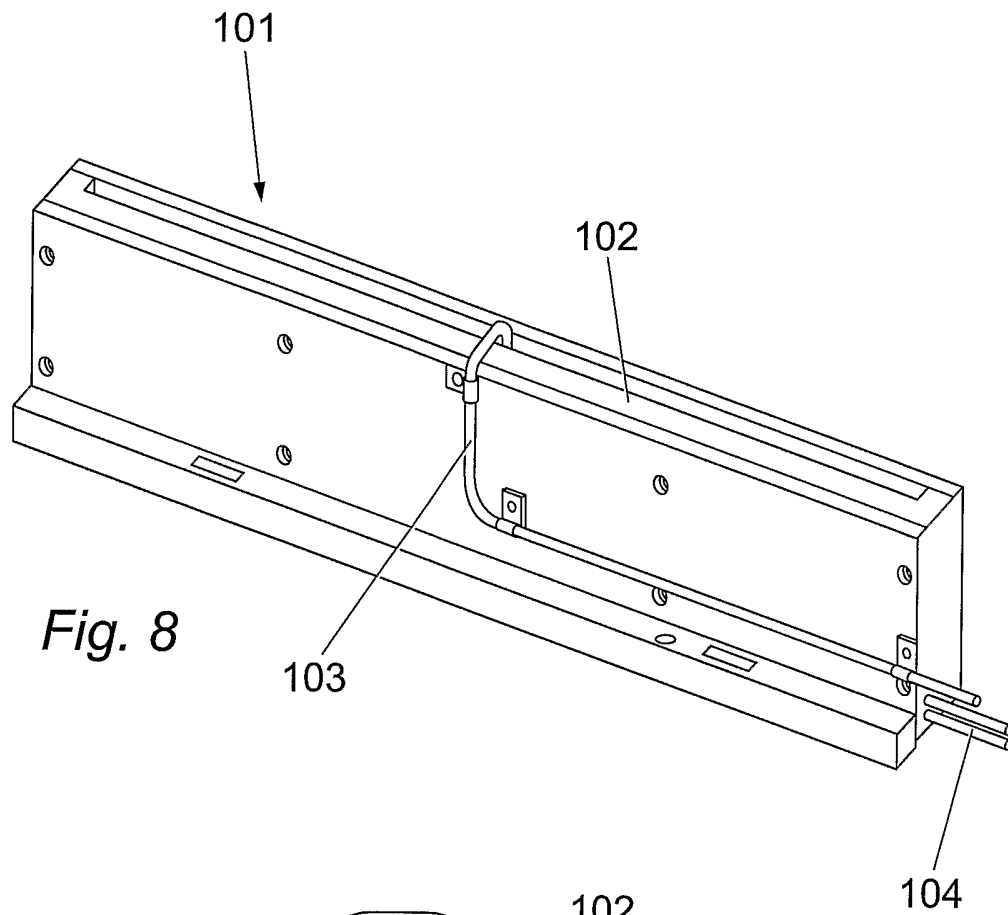
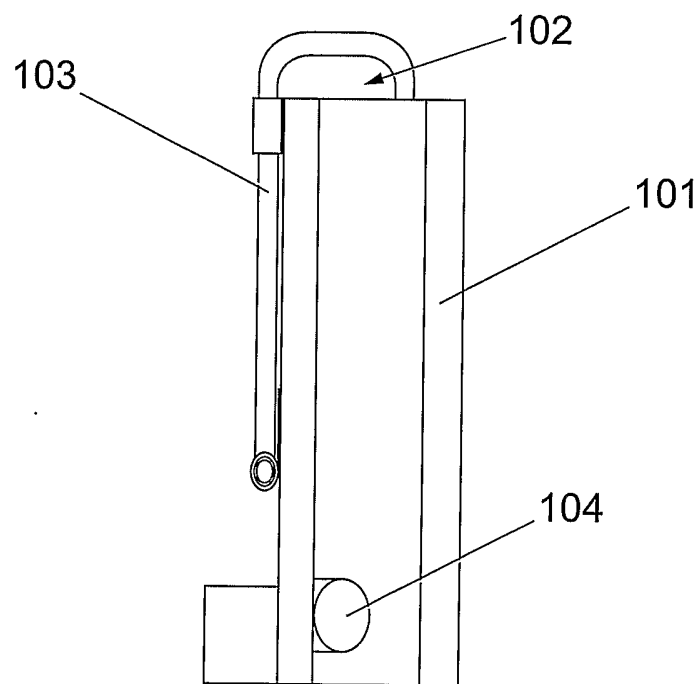

Fig. 7

7 / 8



*Fig. 8*



*Fig. 9*

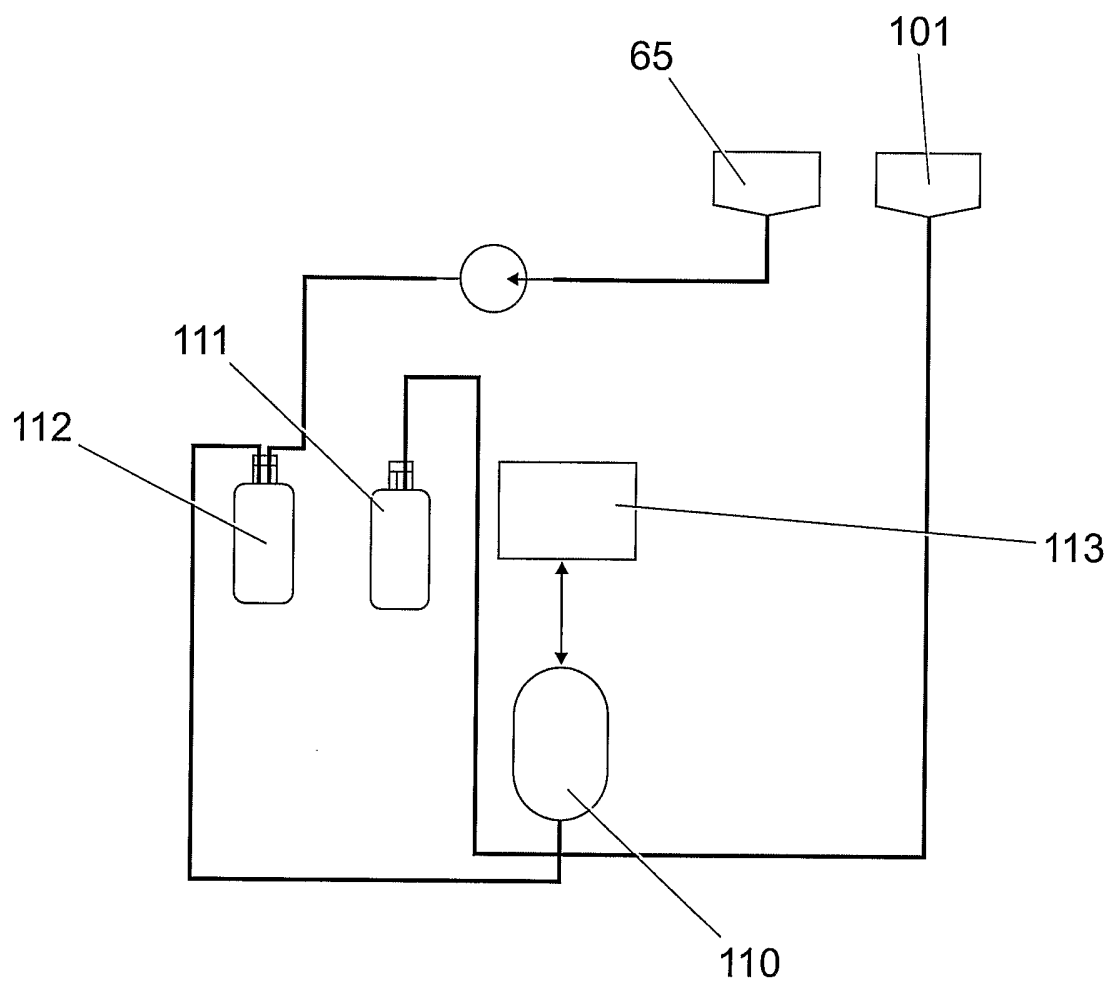

Fig. 10

# INTERNATIONAL SEARCH REPORT

Intern. Application No  
PCT/DK 03/00877

**A. CLASSIFICATION OF SUBJECT MATTER**  
IPC 7 G01N1/31 G01N1/30

According to International Patent Classification (IPC) or to both national classification and IPC

**B. FIELDS SEARCHED**

Minimum documentation searched (classification system followed by classification symbols)  
IPC 7 G01N B01F

Documentation searched other than minimum documentation to the extent that such documents are included in the fields searched

Electronic data base consulted during the international search (name of data base and, where practical, search terms used)

EPO-Internal, WPI Data, PAJ, INSPEC

**C. DOCUMENTS CONSIDERED TO BE RELEVANT**

Category °	Citation of document, with indication, where appropriate, of the relevant passages	Relevant to claim No.
Y	US 2002/072122 A1 (SHOWALTER WAYNE A ET AL) 13 June 2002 (2002-06-13) page 1, paragraph 9 -page 2, paragraph 20; figures 10,14 ---	1-24
Y	US 6 110 425 A (GAO DANIEL DASHUI ET AL) 29 August 2000 (2000-08-29) column 1, line 45 -column 2, line 9; claim 1; figures 5-7 ---	1-24
Y	WO 01 06255 A (BYK GULDEN LOMBERG CHEM FAB ;ISE WOLFGANG (DE)) 25 January 2001 (2001-01-25) claim 1; figures 1,4 ---	1-24
Y	US 4 738 824 A (TAKEUCHI TOSHIYASU) 19 April 1988 (1988-04-19) column 2, line 21 - line 50; figures 1,2 ---	1-24
-/--		

Further documents are listed in the continuation of box C.

Patent family members are listed in annex.

° Special categories of cited documents :

- "A" document defining the general state of the art which is not considered to be of particular relevance
- "E" earlier document but published on or after the international filing date
- "L" document which may throw doubts on priority claim(s) or which is cited to establish the publication date of another citation or other special reason (as specified)
- "O" document referring to an oral disclosure, use, exhibition or other means
- "P" document published prior to the international filing date but later than the priority date claimed

- "T" later document published after the international filing date or priority date and not in conflict with the application but cited to understand the principle or theory underlying the invention
- "X" document of particular relevance; the claimed invention cannot be considered novel or cannot be considered to involve an inventive step when the document is taken alone
- "Y" document of particular relevance; the claimed invention cannot be considered to involve an inventive step when the document is combined with one or more other such documents, such combination being obvious to a person skilled in the art.
- "&" document member of the same patent family

Date of the actual completion of the international search

23 April 2004

Date of mailing of the international search report

1. 05. 04

Name and mailing address of the ISA

European Patent Office, P.B. 5818 Patentlaan 2  
NL - 2280 HV Rijswijk  
Tel. (+31-70) 340-2040, Tx. 31 651 epo nl,  
Fax: (+31-70) 340-3016

Authorized officer

GORDANA NINKOVIC/MN

## INTERNATIONAL SEARCH REPORT

International Application No

PCT/DK 03/00877

## C.(Continuation) DOCUMENTS CONSIDERED TO BE RELEVANT

Category °	Citation of document, with indication, where appropriate, of the relevant passages	Relevant to claim No.
A	US 3 976 028 A (HOWELLS FRANCIS THOMAS ET AL) 24 August 1976 (1976-08-24) abstract; figure 8 ---	1-24
A	US 6 444 170 B1 (HEID HANS ET AL) 3 September 2002 (2002-09-03) column 4, line 16 - line 46; figures 1,2 ---	1-24
A	US 5 338 358 A (MIZUSAWA YOSHITADA ET AL) 16 August 1994 (1994-08-16) abstract ---	1-24
A	US 4 084 541 A (ITO HIROMI) 18 April 1978 (1978-04-18) abstract -----	1-24

# INTERNATIONAL SEARCH REPORT

Information on patent family members

Intern    Application No  
PCT/DK 03/00877

Patent document cited in search report	Publication date	Patent family member(s)	Publication date	
US 2002072122	A1	13-06-2002	US 6352861 B1	05-03-2002
			US 5654200 A	05-08-1997
			US 5595707 A	21-01-1997
			US 2002114733 A1	22-08-2002
			US 2002001849 A1	03-01-2002
			US 2003022391 A1	30-01-2003
			US 6472217 B1	29-10-2002
			US 5650327 A	22-07-1997
			US 5654199 A	05-08-1997
			CA 2077452 A1	03-09-1991
			CA 2299118 A1	03-09-1991
			DE 69117052 D1	21-03-1996
			DE 69117052 T2	14-11-1996
			DK 517835 T3	10-06-1996
			EP 0517835 A1	16-12-1992
			ES 2085471 T3	01-06-1996
			JP 5504627 T	15-07-1993
JP 3186764 B2	11-07-2001			
WO 9113335 A1	05-09-1991			
-----				
US 6110425	A	29-08-2000	NONE	
-----				
WO 0106255	A	25-01-2001	DE 19933153 A1	08-02-2001
			AT 258684 T	15-02-2004
			AU 3659300 A	05-02-2001
			DE 50005148 D1	04-03-2004
			WO 0106255 A1	25-01-2001
			EP 1203235 A2	08-05-2002
-----				
US 4738824	A	19-04-1988	GB 2196428 A	27-04-1988
			DE 3634976 A1	21-04-1988
			FR 2605105 A1	15-04-1988
-----				
US 3976028	A	24-08-1976	GB 1453226 A	20-10-1976
-----				
US 6444170	B1	03-09-2002	NONE	
-----				
US 5338358	A	16-08-1994	JP 3320444 B2	03-09-2002
			JP 5285401 A	02-11-1993
			CA 2078938 A1	07-10-1993
			DE 4233794 A1	14-10-1993
			FR 2689634 A1	08-10-1993
			GB 2265981 A ,B	13-10-1993
			IT 1255718 B	10-11-1995
-----				
US 4084541	A	18-04-1978	JP 1217082 C	17-07-1984
			JP 52088095 A	22-07-1977
			JP 58051220 B	15-11-1983
			JP 52088096 A	22-07-1977
			JP 1169746 C	17-10-1983
			JP 51123690 A	28-10-1976
			JP 58002377 B	17-01-1983
			JP 1237992 C	31-10-1984
			JP 52069692 A	09-06-1977
			JP 59011862 B	19-03-1984
			DE 2617367 A1	04-11-1976
			-----	