

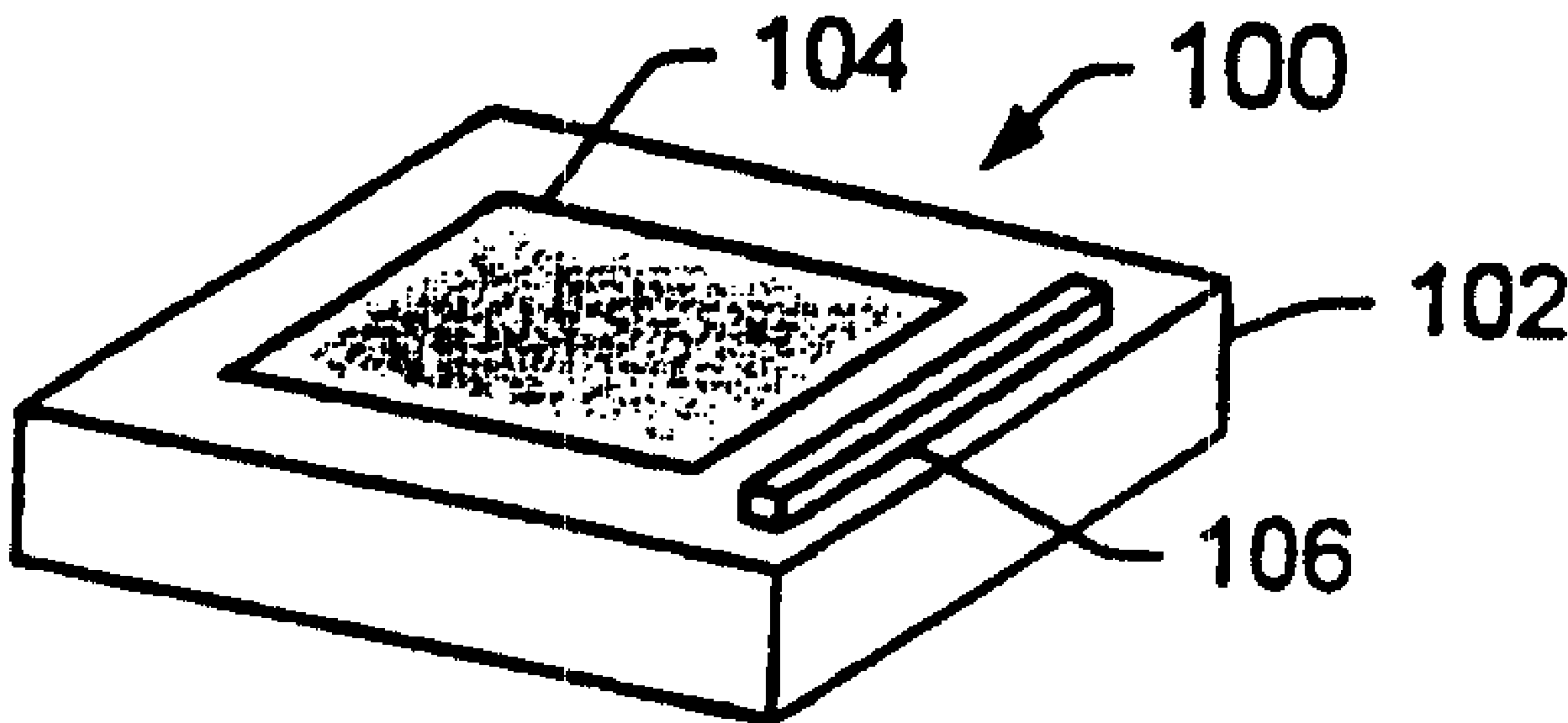

(86) Date de dépôt PCT/PCT Filing Date: 1999/12/14
 (87) Date publication PCT/PCT Publication Date: 2000/06/29
 (45) Date de délivrance/Issue Date: 2005/02/08
 (85) Entrée phase nationale/National Entry: 2001/06/18
 (86) N° demande PCT/PCT Application No.: US 1999/029653
 (87) N° publication PCT/PCT Publication No.: 2000/038217
 (30) Priorités/Priorities: 1998/12/18 (60/112,880) US;
 1999/11/09 (09/437,328) US

(51) Cl.Int.⁷/Int.Cl.⁷ H01J 40/14
 (72) Inventeurs/Inventors:
 WADSWORTH, MARK, US;
 ATLAS, GENE, US
 (73) Propriétaires/Owners:
 CALIFORNIA INSTITUTE OF TECHNOLOGY, US;
 ATLAS, GENE, US
 (74) Agent: SMART & BIGGAR

(54) Titre : FABRICATION D'UN DISPOSITIF D'IMAGERIE HYBRIDE
 (54) Title: FABRICATING A HYBRID IMAGING DEVICE



(57) Abrégé/Abstract:

A hybrid detector or imager includes two substrates fabricated vander incompatible processes. An array of detectors, such as charged-coupled devices, are formed on the first substrate using a CCD fabrication process, such as a buried channel or peristaltic process. One or more charge-converting amplifiers are formed on a second substrate using a CMOS fabrication process. The two substrates are then bonded together to form a hybrid detector.

PCT

WORLD INTELLECTUAL PROPERTY ORGANIZATION
International Bureau

INTERNATIONAL APPLICATION PUBLISHED UNDER THE PATENT COOPERATION TREATY (PCT)

(51) International Patent Classification ⁷ :

H01L

A2

(11) International Publication Number:

WO 00/38217

(43) International Publication Date:

29 June 2000 (29.06.00)

(21) International Application Number: PCT/US99/29653

(22) International Filing Date: 14 December 1999 (14.12.99)

(30) Priority Data:

60/112,880	18 December 1998 (18.12.98)	US
09/437,328	9 November 1999 (09.11.99)	US

(71) Applicant (for all designated States except US): CALIFORNIA INSTITUTE OF TECHNOLOGY [US/US]; 1200 East California Boulevard, Mail Code 201-85, Pasadena, CA 91125 (US).

(72) Inventors; and

(75) Inventors/Applicants (for US only): WADSWORTH, Mark [US/US]; 520 Manzanita Avenue, Serra Madre, CA 91024 (US). ATLAS, Gene [US/US]; 2188 Camino Robledo, Carlsbad, CA 92009 (US).

(74) Agent: HARRIS, Scott, C.; Fish & Richardson, P.C., Suite 1400, 4225 Executive Square, La Jolla, CA 92037 (US).

(81) Designated States: AE, AL, AM, AT, AU, AZ, BA, BB, BG, BR, BY, CA, CH, CN, CR, CU, CZ, DE, DK, DM, EE, ES, FI, GB, GD, GE, GH, GM, HR, HU, ID, IL, IN, IS, JP, KE, KG, KP, KR, KZ, LC, LK, LR, LS, LT, LU, LV, MA, MD, MG, MK, MN, MW, MX, NO, NZ, PL, PT, RO, RU, SD, SE, SG, SI, SK, SL, TJ, TM, TR, TT, TZ, UA, UG, US, UZ, VN, YU, ZA, ZW, ARIPO patent (GH, GM, KE, LS, MW, SD, SL, SZ, TZ, UG, ZW), Eurasian patent (AM, AZ, BY, KG, KZ, MD, RU, TJ, TM), European patent (AT, BE, CH, CY, DE, DK, ES, FI, FR, GB, GR, IE, IT, LU, MC, NL, PT, SE), OAPI patent (BF, BJ, CF, CG, CI, CM, GA, GN, GW, ML, MR, NE, SN, TD, TG).

Published*Without international search report and to be republished upon receipt of that report.*

(54) Title: FABRICATING A HYBRID IMAGING DEVICE

(57) Abstract

A hybrid detector or imager includes two substrates fabricated under incompatible processes. An array of detectors, such as charged-coupled devices, are formed on the first substrate using a CCD fabrication process, such as a buried channel or peristaltic process. One or more charge-converting amplifiers are formed on a second substrate using a CMOS fabrication process. The two substrates are then bonded together to form a hybrid detector.

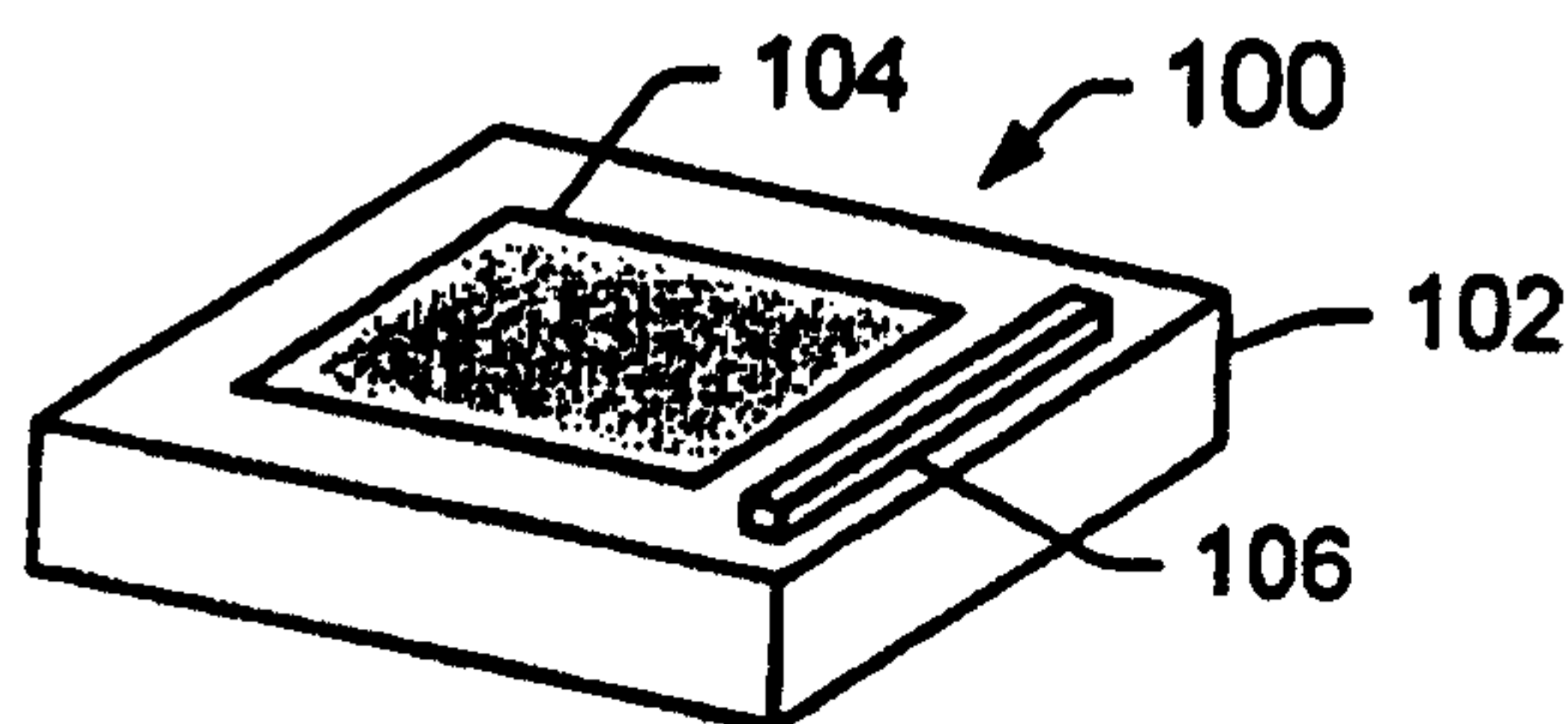

76307-54

1

FABRICATING A HYBRID IMAGING DEVICEStatement as to Federally Sponsored Research

The invention described herein was made in the performance of work under a NASA contract, and is subject to the provisions of Public Law 96-517 (35 USC 202) in which the Contractor has elected to retain title.

Technological Field

This application relates to fabricating a device for use in detecting or imaging electromagnetic radiation, such as photons of light.

Background

Many scientific endeavors, especially space exploration and astronomical measurement applications, require highly sensitive electromagnetic radiation.

detectors, such as photon detectors. Charge-coupled detectors (CCDs) provide high quantum efficiency, broad spectral response, low readout noise, and high resolution. Therefore, CCD devices have been used extensively in scientific applications.

To be effective for most scientific applications, CCD devices must exhibit nearly perfect charge-transfer efficiency. Therefore, CCD devices are fabricated using specialized processes, such as the buried channel and peristaltic fabrication processes, which leave little, if any, imperfections in the semiconductor materials from which the CCD devices are formed. The CCD devices produced by these processes are generally characterized by high power consumption.

Other imaging devices, such as charge injection devices (CIDs) and active pixel sensors (APSs), are formed using conventional complementary metal-oxide semiconductor (CMOS) processes. CMOS devices typically exhibit much lower power consumption than CCD devices. Moreover, CMOS fabrication processes allow other imaging components, such as signal-processing circuitry, to be formed on the detector chip. As a result, CMOS imagers are preferred over CCDs in some scientific applications.

76307-54

3

The use of CMOS imagers has been limited, however, by characteristically low quantum efficiencies and high levels of fixed pattern noise in captured images.

In general, the fabrication processes used to produce CCD and CMOS imagers are incompatible. Conventional CMOS fabrication processes occur, at least in part, at temperatures that produce imperfections in the underlying semiconductor materials. While generally acceptable in CMOS devices, these imperfections typically reduce the efficiency of CCD devices to unacceptable levels.

Summary

In one aspect of the present invention, there is provided a method comprising: forming an array of optical detectors on a first substrate using a first fabrication process; forming at least one charge-converting amplifier on a second substrate using a second fabrication process that is incompatible with the first fabrication process; connecting the first and second substrates together and coupling signals from the first substrate to the second substrate; and acquiring an image of pixels on the first substrate and coupling said pixels to the second substrate in groups less than a total number of pixels in the image.

In a second aspect, there is provided a method comprising: forming an array of optical detectors on a first substrate using a first fabrication process; forming at least one charge-converting amplifier on a second substrate using a second fabrication process that is incompatible with the first fabrication process; and connecting the first and second substrates together and coupling signals from the first substrate to the second substrate; forming a non-destructive sense node on the first substrate for each line

76307-54

3a

of detectors in the array; and reading out each pixel in the array multiple times for each sensed image from said non-destructive sense node to reduce noise in the read-out image.

5 In a third aspect, there is provided a radiation detecting device comprising: a first substrate having a first outer perimeter, with an array of detectors formed on a surface of the substrate forming a top of said first substrate, said array of detectors formed using a first
10 fabrication process; and a second substrate bonded mechanically to the first substrate and physically on top of said first substrate, said second substrate having a second outer perimeter, smaller than said first outer perimeter, and having at least one charge-converting amplifier coupled
15 to receive signals from the detector array, where the charge converting amplifier has a structure that results from a second fabrication process that is incompatible with the first fabrication process.

 In a fourth aspect, there is provided a radiation
20 detecting device comprising: a first substrate having an array of detectors formed on a surface of the substrate with a structure that results from a first fabrication process; a second substrate bonded mechanically to the first substrate and having at least one charge-converting amplifier coupled
25 to receive signals from the detector array, where the amplifier has a structure that results from a second fabrication process that is incompatible with the first fabrication process; and a non-destructive sense node formed on the first substrate for each line of detectors in the
30 array.

 In a fifth aspect, there is provided a radiation imaging device comprising: a first substrate having: an

76307-54

3b

array of charge-coupled detectors (CCDs); and a serial output register coupled electrically to the CCDs in the array; and a second substrate bonded mechanically to the first substrate and having: a complementary metal-oxide semiconductor (CMOS) charge-converting amplifier coupled electrically to the serial output register to convert charge collected in the CCDs into a voltage-mode signal; CMOS processing circuitry coupled to receive the voltage-mode signal from the charge-converting amplifier and to change some aspect of the voltage-mode signal; and CMOS timing and control circuitry coupled electrically to the CCDs to control charge transfer from the CCDs to the charge-converting amplifier.

In a sixth aspect, there is provided a radiation imaging device comprising: a first substrate having: an array of charge-coupled detectors (CCDs) arranged into parallel lines; and for each of the lines in the array, a nondestructive sense node coupled to the CCDs in the line and configured to sense charge collected by the CCDs in the line; and a second substrate bonded mechanically to the first substrate and having: for each of the lines in the array, a complementary metal-oxide semiconductor (CMOS) averaging circuit coupled to the sense node and configured to average an amount of charge collected by each of the CCDs in the line at multiple sampling instants; for each of the lines in the array, a CMOS charge-converting amplifier coupled to the averaging circuit and configured to convert, for each of the CCDs in the line, the charge collected by the CCD over the multiple sampling instants into a voltage-mode signal; a CMOS multiplexer connected to receive the voltage-mode signal from each charge-converting amplifier; CMOS image processing circuitry coupled to receive the voltage-mode signal from the multiplexer; and CMOS timing

76307-54

3c

and control circuitry coupled to the CCDs in the array and configured to control charge transfer from the CCDs.

In a seventh aspect, there is provided a method comprising: detecting incoming radiation with an array of
5 detectors formed on a first substrate; delivering a charge-mode signal generated by the detector array in response to the radiation from the first substrate to a second substrate; and converting the charge-mode signal into a voltage-mode signal, using an amplifier formed on the second
10 substrate.

The techniques described here combine benefits of CCD and CMOS devices without integrating CCD and CMOS fabrication process technologies. The resulting detectors and imagers exhibit the performance benefits of CCD devices,
15 including high quantum efficiency, high fill factor, broad spectral response, and very low noise levels, as well as the low power consumption and ease of component integration associated with CMOS devices.

Because the CCD and CMOS portions of an imaging
20 device are manufactured in separate processes using

separate substrates, the CCD and CMOS portions can be tuned separately for optimum noise performance.

Moreover, fabricating the CCD and CMOS components from separate substrates allows the use of backside thinning and illumination techniques, as well as backside passivation techniques such as delta doping.

In some aspects, the invention features techniques for fabricating a radiation detector, such as an imaging device. An array of detectors, such as charged-coupled devices, are formed on a first substrate using a CCD fabrication process, such as a buried channel or peristaltic process. One or more charge-converting amplifiers are formed on a second substrate, typically using a CMOS fabrication process. The two substrates are then bonded together to form a hybrid detector.

Other embodiments and advantages will become apparent from the following description and from the claims.

20

Description of the Drawings

FIG. 1 is a perspective view of a hybrid radiation imaging chip that includes both CCD and CMOS components.

FIG. 2 is a schematic diagram of a hybrid radiation imaging chip that includes both CCD and CMOS components.

FIG. 3 is a flow chart of a process for fabricating a hybrid radiation imaging chip using both CCD and CMOS processes.

FIG. 4 is a schematic diagram of another hybrid radiation imaging chip that includes both CCD and CMOS components.

FIG. 5 is a flow chart of a process for calibrating a hybrid imaging chip.

Detailed Description

FIG. 1 shows a perspective view of a hybrid CCD-CMOS imaging chip 100. The imaging chip includes a substrate 102 that has a CCD array 104 formed on one surface by a conventional CCD fabrication process, such as a buried channel or peristaltic process. A conventional CCD device includes a buried-channel amplifier in the CCD substrate that converts charge collected in the CCD array into voltage-mode signals. The CCD portion of the hybrid chip 100 does not include such an amplifier.

A CMOS-based gain stage is formed on another substrate 106 by a conventional CMOS fabrication process.

This gain stage replaces the buried-channel amplifier normally formed on a CCD chip. As described below, the two substrates 102, 106 are bonded together after the CCD and CMOS circuits are formed. This eliminates any need
5 to integrate the CCD and CMOS fabrication processes together. In many implementations, signal processing electronics can be formed on the CMOS substrate 106 to provide full imaging capability on the hybrid chip 100.

FIG. 2 shows a block diagram of the hybrid imaging
10 chip 100. The CCD substrate 102 includes individual detector elements 115A-L, or "pixels," arranged as a CCD array 104. As in a conventional CCD imaging device, the array 104 includes one or more lines 110A-D (rows or columns) of CCDs coupled to a high-speed serial register
15 112. Upon exposure to electromagnetic radiation, the pixels 115A-L collect charge in capacitively coupled potential wells formed in a semiconductor layer, such as an epitaxial silicon layer. Optically transparent control gates formed on the image area hold the collected
20 charge in the potential wells. The pixels 115A-L transfer the collected charge along the lines 110A-D to the high-speed serial register 112 in response to a series of pulses applied to the control gates.

The high-speed serial register 112 on the CCD substrate 102 is coupled to a CMOS charge-mode amplifier 114 formed on the CMOS substrate 106. In one implementation, the charge-mode amplifier 114 is an operational amplifier configured as a charge integrator. This amplifier 114 can lower the noise during charge collection. Because the CMOS charge-mode amplifier 114 is not formed on the substrate 102 on which the imaging array 104 is formed, the amplifier 114 is not subject to size constraints. As a result, the amplifier 114 can include components that are sized to yield optimum 1/f and thermal noise performance. Thus, the amplifier 114 can outperform amplifiers found in conventional CMOS imaging devices, such as CID and APS devices. Because the amplifier 114 is a CMOS device, it also consumes very little power, typically an order of magnitude less than conventional CCD amplifiers.

In some implementations, the CMOS substrate 106 also includes CMOS signal processing circuitry, such as a double-sampling circuit 116, an analog-to-digital converter (ADC) 118, and a digital signal processor (DSP) 120. These components provide noise reduction and image processing capability on the hybrid imaging chip 100.

The CMOS substrate 106 also includes timing and control circuitry 122 that controls the transfer of charge from the pixels 115A-L in the array 104 to the high-speed serial register 112. In a conventional CCD imaging device, the timing and control circuitry is often formed on a separate chip.

In some implementations, the CCD and CMOS components are coupled by electrically conductive pads 124A-F formed on the CCD substrate 102 and the CMOS substrate 106. These pads 124A-F are aligned to allow mechanical and electrical interconnection of the substrates 102, 106. A conventional flip-chip technique using an infrared (IR) microscope and alignment marks on the CCD and CMOS substrates can be used to align the substrates.

FIG. 3 illustrates an overview of a technique for fabricating the hybrid imaging chip 100. The imaging array is formed on one substrate using a conventional CCD fabrication process, such as the buried channel and peristaltic CCD fabrication processes (step 130). Likewise, the charge-mode amplifier, the signal processing circuitry, and the timing and control circuitry are formed on another substrate using a conventional CMOS fabrication process (step 132).

Bonding pads are formed on each substrate during these fabrication processes. The fabrication processes are optimized individually to produce circuits capable of the highest performance quality.

5 Once the substrates have been fabricated, a bonding material is placed on the bonding pads (step 134), and the CMOS substrate is positioned on the CCD substrate (step 136). The two substrates are then bonded together using any of a variety of techniques (step 138).

10 Examples of such techniques include conventional bump-bonding techniques.

FIG. 4 shows another structure for a hybrid CCD-CMOS imaging chip 150. This imaging chip 150 includes a non-destructive sense node 152A-D, implemented in this

15 example as a floating polysilicon gate, for each line 154A-D in the CCD array 156. These sense nodes 152A-D replace the usual high-speed serial register. The non-destructive sense nodes 152A-D are typically formed on the CCD substrate 155 and operate as described below.

20 The imaging chip 150 includes CMOS charge-mode amplifiers 158A-D formed on the CMOS substrate 165. Each is coupled to one of the non-destructive sense nodes 152A-D. Each of the amplifiers 158A-D also is coupled to

a corresponding averaging circuit 160A-D. In many implementations, a double-sampling circuit 164A-D is formed between each pair of amplifiers 158A-D and averaging circuits 160A-D.

5 A high-speed CMOS multiplexer 162 receives voltage-mode signals from the averaging circuits 160A-D and delivers a single signal to an analog-to-digital converter (ADC) 166. The ADC 166 digitizes the signal and delivers it to a digital signal processor (DSP) 168.
10 A look-up table 174 is stored in a storage device, such as a writable read-only memory (ROM) device, for use by the DSP 168, as described below.

 A timing and control circuit 170 on the CMOS substrate 165 delivers control signals to the CCD array
15 156, the non-destructive sense nodes 152A-D, the averaging circuits 160A-D, and the CMOS multiplexer 162. Optional bonding pads 172A-J are formed on the CCD and CMOS substrates 155, 165 to allow mechanical and electrical interconnection between the substrates.

20 The non-destructive sense nodes 152A-D, the CMOS amplifiers 158A-D, and the averaging circuits 160A-D together provide parallel channels for converting the charge collected in each of the lines 154A-D of the CCD

array 156. In general, the CCD array 156 is capable of transferring charge at a rate much higher than that required in scientific applications. For example, a typical application might require transferring data from a 128 x 128 array to the signal processing circuitry at an effective rate of 10 frames per second, or 1.28 kHz per line. A typical CCD array, however, can support a much higher line transfer rate, e.g., 128 kHz.

Therefore, the CCD array 156 in this example can support 100 samples from each detector in the array 156 between each transfer to the digital signal processor 168.

Since the sense nodes 152A-D are non-destructive, the charge in those nodes can be repeatedly measured. The averaging circuits 160A-D connected to the CMOS amplifiers 158A-D average or accumulate the samples measured during successive sampling periods of, for example, 100 samples. At the end of each sampling period, the averaging circuits 160A-D deliver the stored charge to the high-speed multiplexer 162.

This type of parallel charge measurement reduces readout noise by a factor approximately equivalent to the square root of the number of samples taken for each pixel. For a 128 x 128 array operating at a transfer

rate of 10 frames per second, readout noise is reduced from approximately 4 electrons rms to approximately 0.4 electrons rms.

FIG. 5 illustrates a technique for use in
5 calibrating the parallel hybrid imaging chip 150 of FIG. 4 to improve image quality. In general, this technique allows for correction of column-to-column offset and gain variations that often result from minor differences in CMOS amplifier geometries. This technique is carried out
10 in the digital signal processor 168 (FIG. 4) or in other processing circuitry, such as a programmable processor, in the imaging chip or another chip.

The signal processing circuitry first reads all or a portion of a uniform image, such as a dark current
15 generated by pixels in an optically opaque portion of the imaging field (step 180). The DSP or other processing circuitry calculates an average image value in the uniform image (step 182). For each line in the array, a variance between the measured charge and the average
20 value is calculated (step 184). The processing circuitry normalizes the variances (step 186). The normalized variances represent the amount of gain variation among

the CMOS amplifiers. These normalized variances are stored in the look-up table described above (step 188).

The processing circuitry retrieves and applies the normalized variances during normal operation of the imaging chip (step 190). In general, applying the normalized variances involves multiplying the values stored in the look-up table with the real-time measurements of corresponding pixels in the array. Normalizing the measured values in this manner eliminates the effects of gain variations among the amplifiers.

The invention has been described in terms of particular embodiments. Various modifications can be made without departing from the spirit and scope of the invention. For example, while the invention has been described in terms of photon detection and imaging, it is also useful in detecting and imaging other types of radiation, including charged particles. Also, the imaging circuit often varies among implementations. For example, some implementations do not include dedicated averaging circuits for each line of the array, but rather implement the averaging function in the digital signal processor 168 (FIG. 4). Likewise, other types of capacitively coupled detectors, such as "bucket-brigade"

detectors implemented with bipolar junction transistors, can be used. Also, while electrical connection between the substrates is described, other forms of signal coupling, such as optical coupling, is contemplated.

5 Accordingly, other embodiments are within the scope of the following claims.

76307-54

15

CLAIMS:

1. A method comprising:

forming an array of optical detectors on a first substrate using a first fabrication process;

5 forming at least one charge-converting amplifier on a second substrate using a second fabrication process that is incompatible with the first fabrication process;

connecting the first and second substrates together and coupling signals from the first substrate to
10 the second substrate; and

acquiring an image of pixels on the first substrate and coupling said pixels to the second substrate in groups less than a total number of pixels in the image.

2. The method of claim 1, further comprising forming
15 bonding pads on the first and second substrates.

3. The method of claim 2, further comprising placing a bonding material between the bonding pads before bonding the substrates together.

4. The method of claim 1, wherein forming at least
20 one charge-converting amplifier includes forming one amplifier for each line of detectors in the array.

5. A method comprising:

forming an array of optical detectors on a first substrate using a first fabrication process;

25 forming at least one charge-converting amplifier on a second substrate using a second fabrication process that is incompatible with the first fabrication process; and

76307-54

16

connecting the first and second substrates together and coupling signals from the first substrate to the second substrate;

forming a non-destructive sense node on the first
5 substrate for each line of detectors in the array; and

reading out each pixel in the array multiple times for each sensed image from said non-destructive sense node to reduce noise in the read-out image.

6. The method of claim 5, wherein each non-
10 destructive sense node includes a floating gate device.

7. The method of claim 5, further comprising averaging a plurality of values of the multiple pixels that were read out multiple times to represent the same information.

15 8. The method as in claim 1, further comprising serially reading out values from a serial output register on the first substrate.

9. The method of claim 1, wherein forming at least one charge-converting amplifier includes forming the
20 amplifier as a complementary metal-oxide semiconductor (CMOS) device.

10. The method of claim 1, further comprising forming noise and signal processing circuitry on the second substrate.

5 11. The method of claim 1, further comprising forming timing and control circuitry on the second substrate.

12. The method of claim 11, further comprising:
10 forming a bonding pad on the first substrate and a mating bonding pad on the second substrate;
coupling the bonding pads formed on the second substrate to the timing and control circuitry;
coupling the bonding pads formed on the first
15 substrate to one or more control gates in the detector array; and
bonding the bonding pads together.

13. The method of claim 12, wherein forming the
20 array of detectors includes forming capacitively coupled charge wells on the first substrate.

76307-54

18

14. A radiation detecting device comprising:

a first substrate having a first outer perimeter, with an array of detectors formed on a surface of the substrate forming a top of said first substrate, said array
5 of detectors formed using a first fabrication process; and

a second substrate bonded mechanically to the first substrate and physically on top of said first substrate, said second substrate having a second outer perimeter, smaller than said first outer perimeter, and
10 having at least one charge-converting amplifier coupled to receive signals from the detector array, where the charge converting amplifier has a structure that results from a second fabrication process that is incompatible with the first fabrication process.

15 15. The device of claim 14, further comprising a bonding pad formed on the first substrate and a mating bonding pad formed on the second substrate.

16. The device of claim 15, further comprising a bonding material placed between the bonding pads.

20 17. The device of claim 14, wherein the second substrate includes at least one charge-converting amplifier for each line of detectors in the array.

18. A radiation detecting device comprising:

a first substrate having an array of detectors
25 formed on a surface of the substrate with a structure that results from a first fabrication process;

a second substrate bonded mechanically to the first substrate and having at least one charge-converting amplifier coupled to receive signals from the detector

76307-54

19

array, where the amplifier has a structure that results from a second fabrication process that is incompatible with the first fabrication process; and

5 a non-destructive sense node formed on the first substrate for each line of detectors in the array.

19. The device of claim 18, wherein each non-destructive sense node includes a floating gate device.

20. The device of claim 18, further comprising an averaging circuit formed on the second substrate for each
10 line of detectors in the array, operating to average plural readout signals, representing the same information.

21. The device of claim 14, further comprising a serial output register formed on the first substrate and coupled to the detector array.

15 22. The device of claim 14, wherein each charge-converting amplifier includes a complementary metal-oxide semiconductor (CMOS) amplifier.

23. The device of claim 14, further comprising signal processing circuitry formed on the second substrate.

24. The device of claim 14, further comprising timing and control circuitry formed on the second substrate.

5 25. The device of claim 24, further comprising a bonding pad formed on the second substrate and coupled to the timing and control circuitry, and a bonding pad formed on the first substrate and coupled to one or more control gates in the detector array.

10

26. A radiation imaging device comprising:
a first substrate having:

an array of charge-coupled detectors

(CCDs); and

15

a serial output register coupled

electrically to the CCDs in the array; and

a second substrate bonded mechanically to the first substrate and having:

a complementary metal-oxide semiconductor

20

(CMOS) charge-converting amplifier coupled

electrically to the serial output register to

convert charge collected in the CCDs into a

voltage-mode signal;

CMOS processing circuitry coupled to receive the voltage-mode signal from the charge-converting amplifier and to change some aspect of the voltage-mode signal; and

5 CMOS timing and control circuitry coupled electrically to the CCDs to control charge transfer from the CCDs to the charge-converting amplifier.

10 27. A radiation imaging device comprising:

a first substrate having:

an array of charge-coupled detectors (CCDs) arranged into parallel lines; and

15 for each of the lines in the array, a non-destructive sense node coupled to the CCDs in the line and configured to sense charge collected by the CCDs in the line; and

a second substrate bonded mechanically to the first substrate and having:

20 for each of the lines in the array, a complementary metal-oxide semiconductor (CMOS) averaging circuit coupled to the sense node and configured to average an amount of charge

collected by each of the CCDs in the line at multiple sampling instants;

for each of the lines in the array, a CMOS charge-converting amplifier coupled to the averaging circuit and configured to convert, for each of the CCDs in the line, the charge collected by the CCD over the multiple sampling instants into a voltage-mode signal;

a CMOS multiplexer connected to receive the voltage-mode signal from each charge-converting amplifier;

CMOS image processing circuitry coupled to receive the voltage-mode signal from the multiplexer; and

CMOS timing and control circuitry coupled to the CCDs in the array and configured to control charge transfer from the CCDs.

28. A method comprising:

detecting incoming radiation with an array of detectors formed on a first substrate;

76307-54

23

delivering a charge-mode signal generated by the detector array in response to the radiation from the first substrate to a second substrate; and

5 converting the charge-mode signal into a voltage-mode signal, using an amplifier formed on the second substrate.

29. The method of claim 28, further comprising delivering charge from the detector array to a serial register on the first substrate.

10 30. The method of claim 29, when delivering the charge-mode signal from the first substrate to the second substrate includes delivering the charge-mode signal from the serial register to a charge-mode amplifier on the second substrate.

15 31. The method of claim 28, wherein delivering the charge-mode signal includes delivering charge from each line of detectors in the array to a corresponding charge-mode amplifier on the second substrate.

32. The method of claim 31, further comprising delivering a voltage-mode signal from each charge-mode amplifier to an averaging circuit on the second substrate.

5

33. The method of claim 31, wherein delivering charge from each line of detectors includes sensing charge from each line of detectors at a corresponding non-destructive sense node.

10

34. The method of claim 28, further comprising delivering timing and control signals from the second substrate to the detector array.

76307-54

25

35. A device as in claim 18, further comprising a control circuit, controlling readout of values in said optical detectors, said control controlling said optical detectors to be read out a plurality of times for each
5 desired readout image to read the same information said plurality of times.

36. A device as in claim 26, further comprising a plurality of output nodes respectively associated with the array of charge coupled detectors, each of said output nodes
10 being nondestructive sense nodes which can be read out a plurality of times for the same information, while retaining the information therein.

37. A device as in claim 36, further comprising an averaging circuit, receiving a plurality of values
15 representing the same information about the same image, and providing an averaged version of said plurality of values.

SMART & BIGGAR
OTTAWA, CANADA

PATENT AGENTS

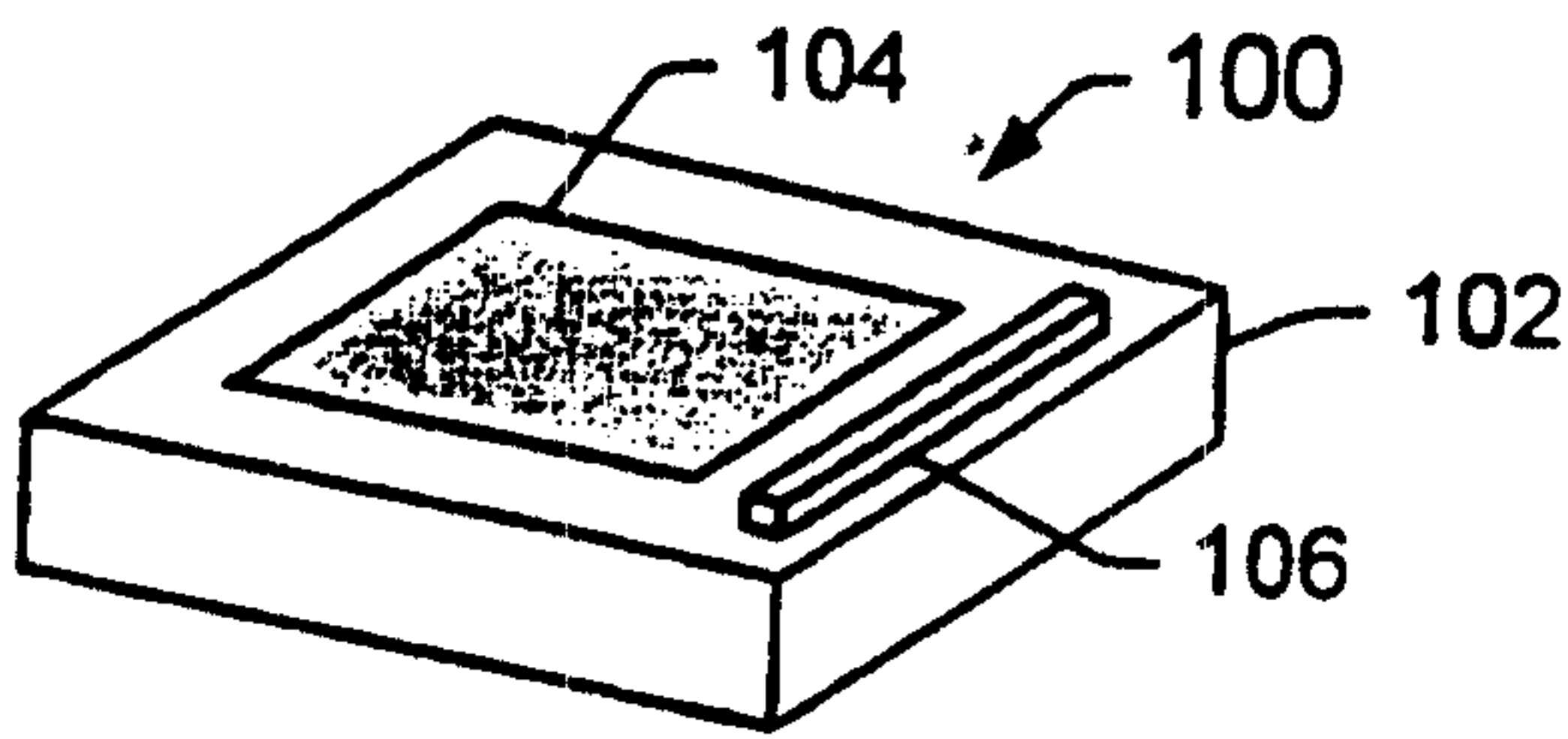

FIG. 1

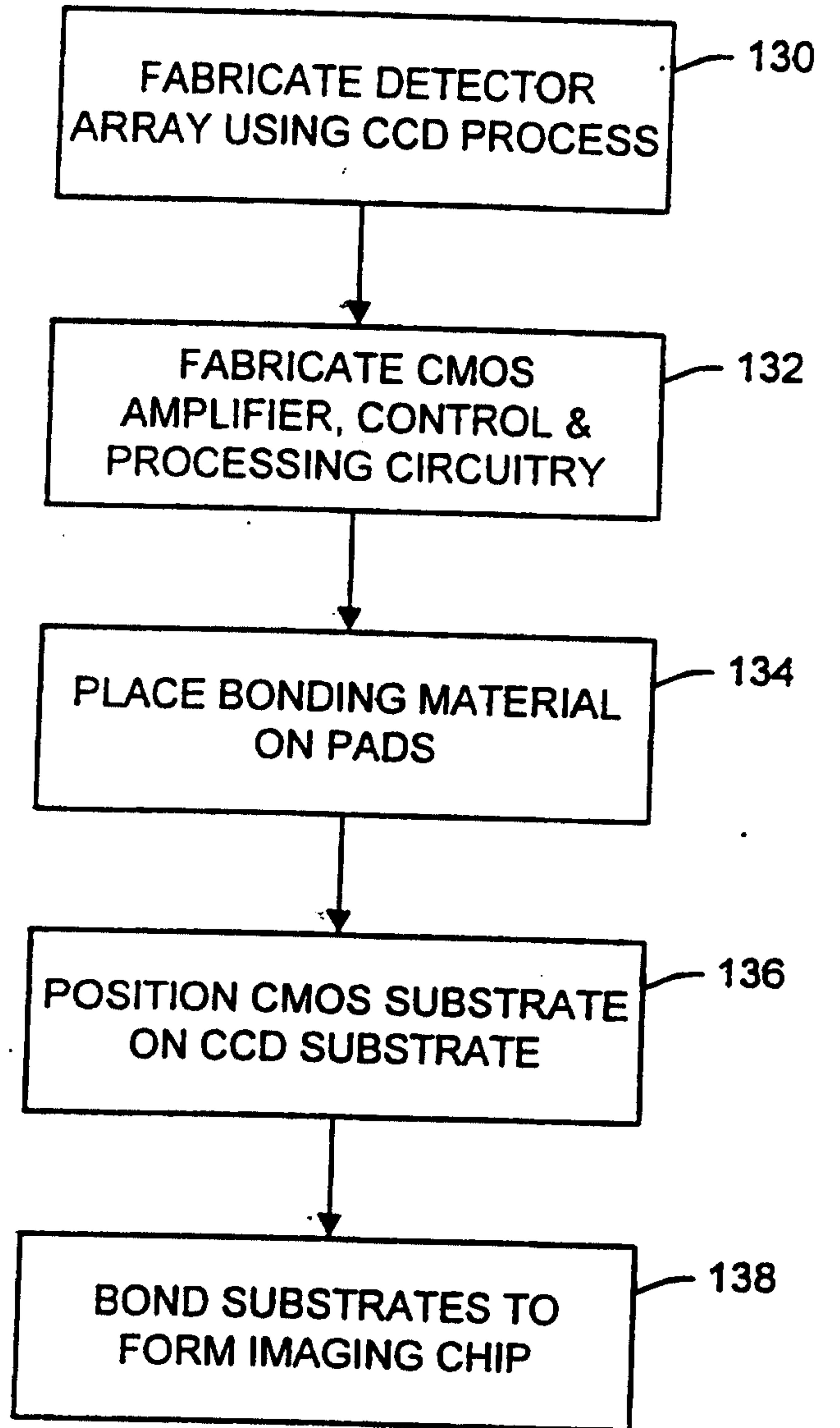

FIG. 3

2/4

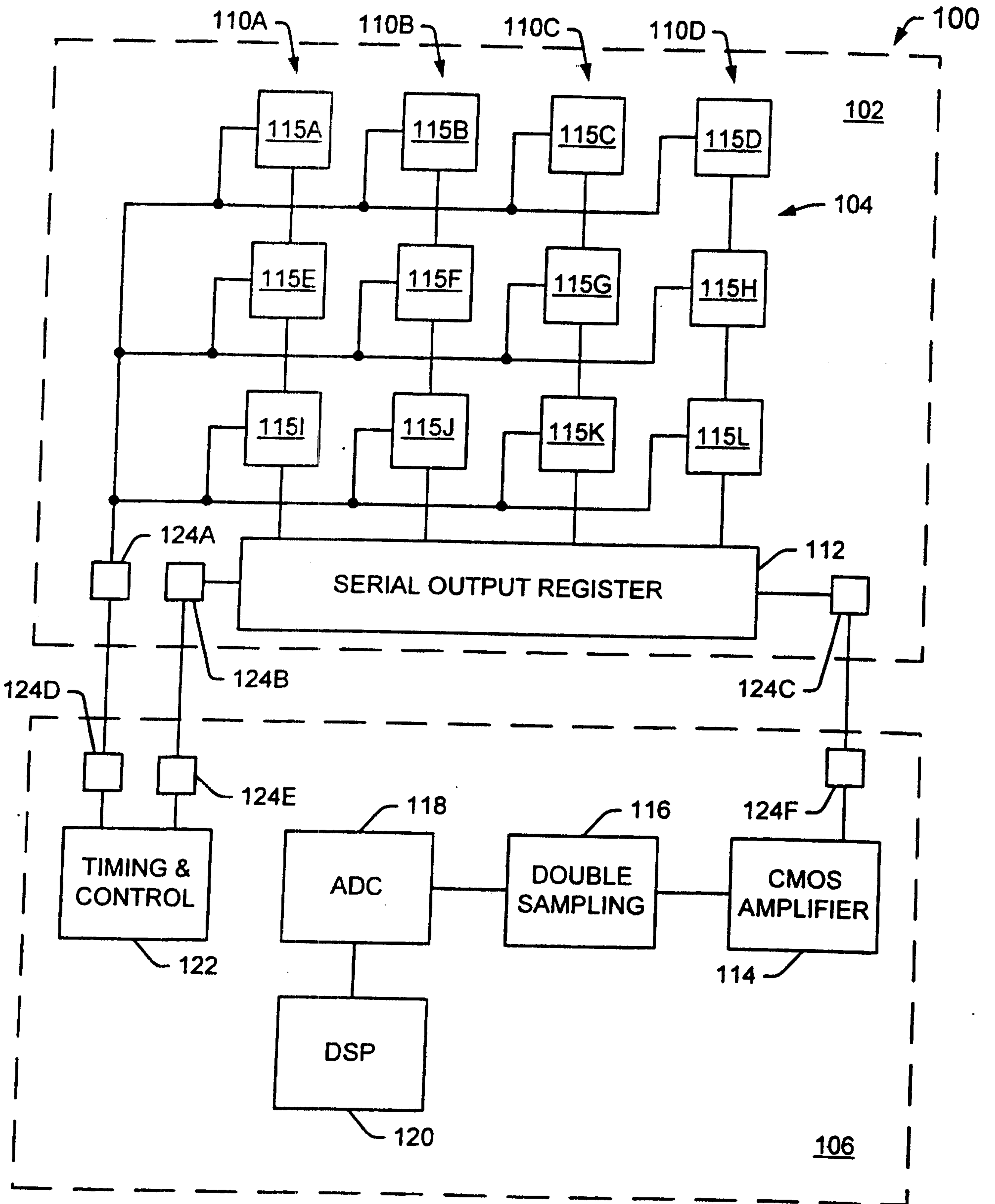

FIG. 2

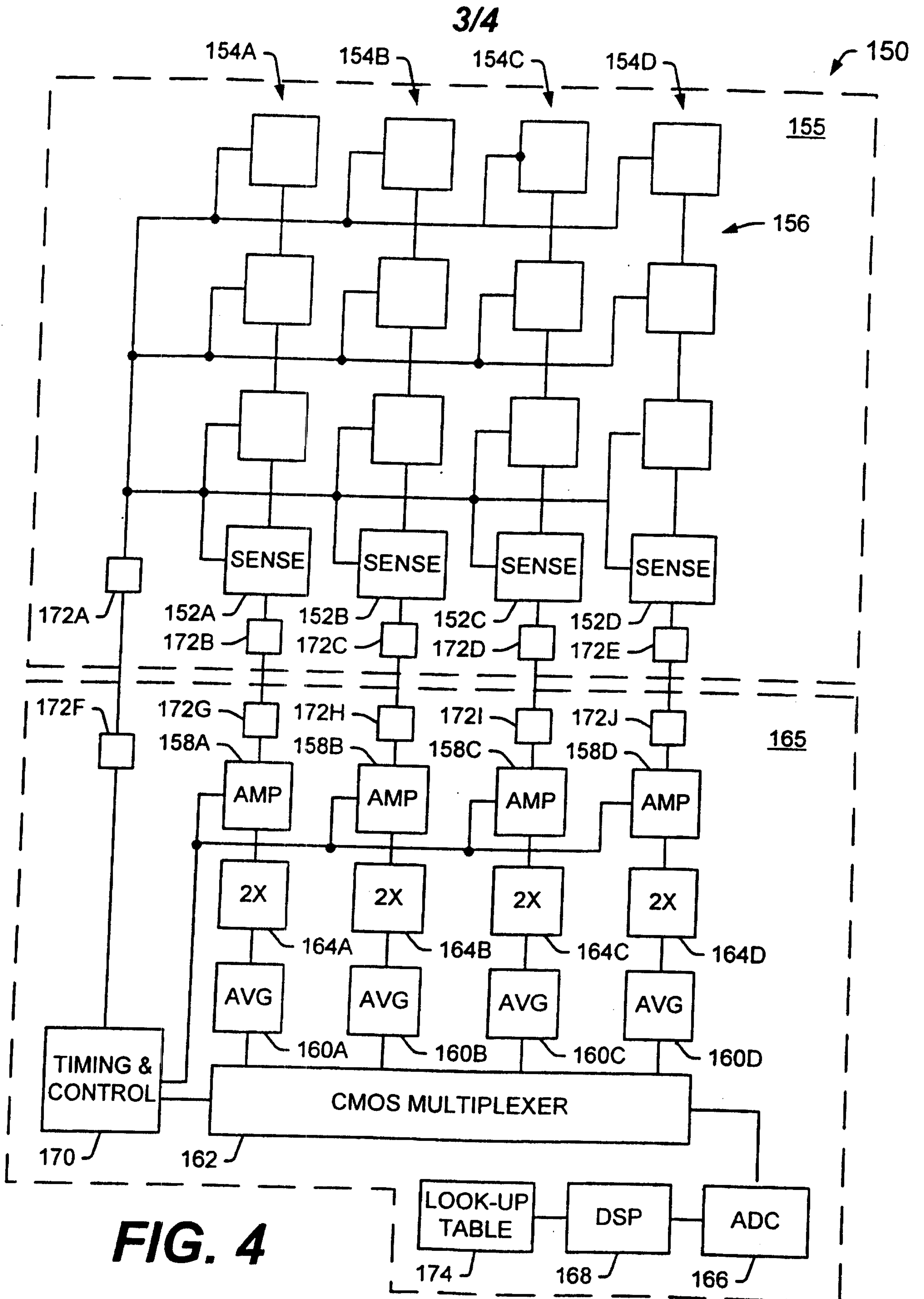
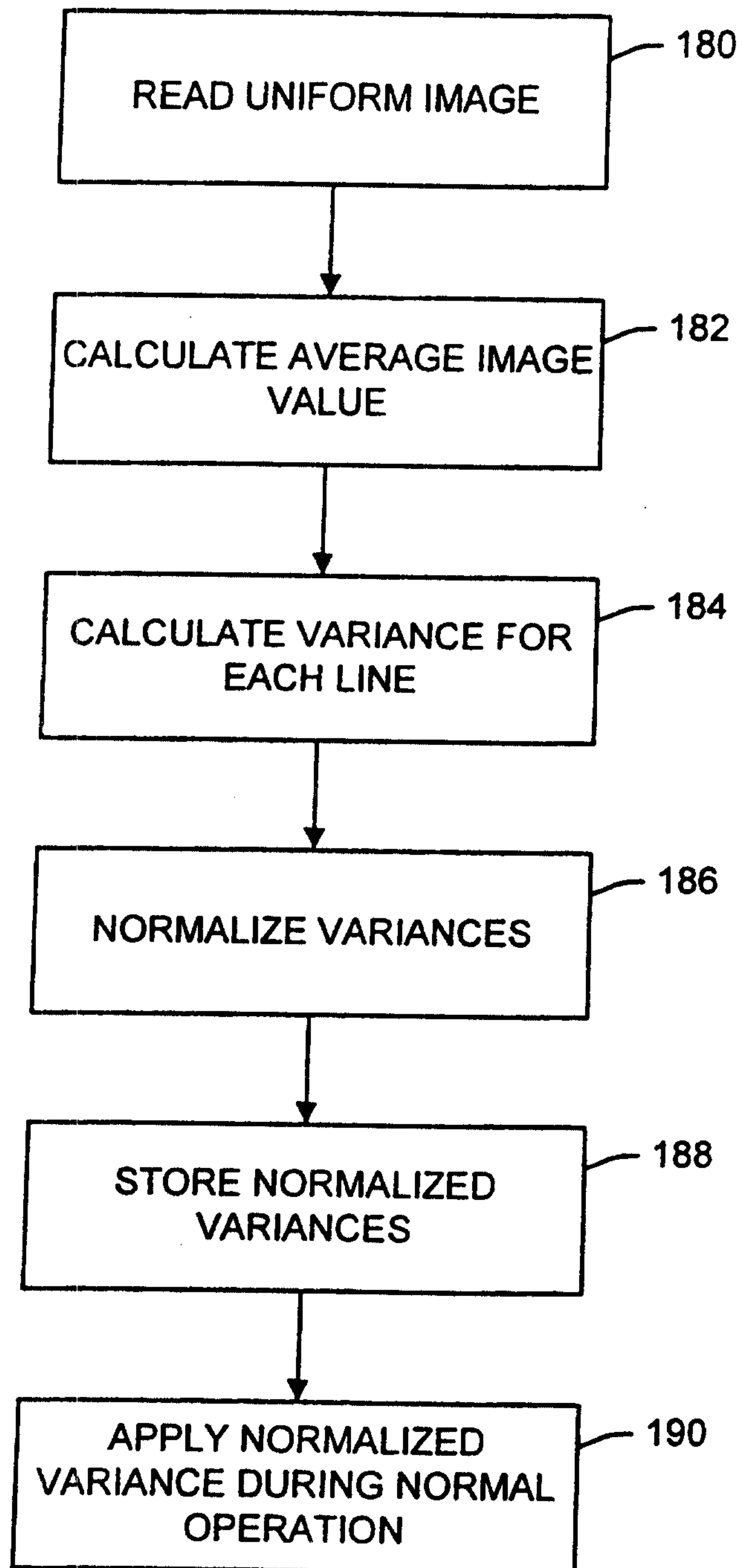

FIG. 4

4/4

**FIG. 5**

