



(51) International Patent Classification:

F04C 2/40 (2006.01) F01C 1/40 (2006.01)
F04C 18/40 (2006.01) F03C 2/30 (2006.01)

17310 Meria Coves Drive, Houston, Texas 77095 (US).
BURNS, Timothy Donald Sr. [US/US]; 437 Shannon Road, McAlester, Oklahoma 74501 (US).

(21) International Application Number:

PCT/AU2012/000822

(74) Agent: **GRIFFITH HACK**; Level 19, 109 St Georges Terrace, Perth, Western Australia 6000 (AU).

(22) International Filing Date:

6 July 2012 (06.07.2012)

(81) Designated States (unless otherwise indicated, for every kind of national protection available): AE, AG, AL, AM, AO, AT, AU, AZ, BA, BB, BG, BH, BR, BW, BY, BZ, CA, CH, CL, CN, CO, CR, CU, CZ, DE, DK, DM, DO, DZ, EC, EE, EG, ES, FI, GB, GD, GE, GH, GM, GT, HN, HR, HU, ID, IL, IN, IS, JP, KE, KG, KM, KN, KP, KR, KZ, LA, LC, LK, LR, LS, LT, LU, LY, MA, MD, ME, MG, MK, MN, MW, MX, MY, MZ, NA, NG, NI, NO, NZ, OM, PE, PG, PH, PL, PT, QA, RO, RS, RU, RW, SC, SD, SE, SG, SK, SL, SM, ST, SV, SY, TH, TJ, TM, TN, TR, TT, TZ, UA, UG, US, UZ, VC, VN, ZA, ZM, ZW.

(25) Filing Language:

English

(26) Publication Language:

English

(30) Priority Data:

61/505,625 8 July 2011 (08.07.2011) US
61/608,844 9 March 2012 (09.03.2012) US

(71) Applicant (for all designated States except US): **GREY-STONE TECHNOLOGIES PTY LTD** [AU/AU]; Unit 2, 39 Colin Jamieson Drive, Welshpool, Western Australia 6106 (AU).

(72) Inventors; and

(75) Inventors/Applicants (for US only): **WHEELER, Daryl** [AU/AU]; Unit 2, 7 Rocklea Place, Silver Sands, Western Australia 6210 (AU). **ERWIN, Justin Wade** [US/US];

(84) Designated States (unless otherwise indicated, for every kind of regional protection available): ARIPO (BW, GH, GM, KE, LR, LS, MW, MZ, NA, RW, SD, SL, SZ, TZ, UG, ZM, ZW), Eurasian (AM, AZ, BY, KG, KZ, RU, TJ, TM), European (AL, AT, BE, BG, CH, CY, CZ, DE, DK, EE, ES, FI, FR, GB, GR, HR, HU, IE, IS, IT, LT, LU, LV,

[Continued on next page]

(54) Title: ROTARY FLUID MACHINE

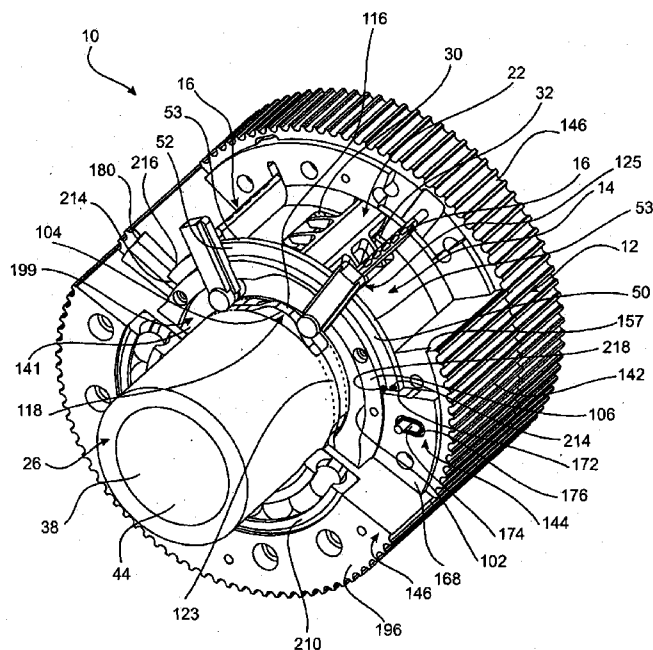

Fig 1

(57) Abstract: A rotary fluid machine (10) has a rotor (12), a stator (14), and a plurality of gates. The rotor (12) and stator (14) are rotatable relative to each other and arranged one inside the other to define a working chamber (18) there between. Gates (16) are supported in radial gate slots (20) formed in the rotor (12) and cyclically extend from and retract into the gate (slots 20) as the rotor (12) rotates about stator (14). A plurality of demountable lobes is supported on an outer circumferential surface (24) of stator (14). The surface (24) forms a surface of the working chamber (18). Circumferential surface (24) is composed of an intermediate surface (48) which extends in an axial direction and opposite curved surfaces (46). The gate (16) has opposite rounded corners (130) separated by an axial planar surface (132). The shape and configuration of the gate (16) and corresponding is made to match that of the outer circumferential surface (24) so that when the axial surface (132) lies substantially adjacent and parallel to intermediate surface (48) each of the curved surfaces (130) lie closely adjacent to and substantially parallel with the concavely curved surfaces (46).

WO 2013/006902 A1



MC, MK, MT, NL, NO, PL, PT, RO, RS, SE, SI, SK,
SM, TR), OAPI (BF, BJ, CF, CG, CI, CM, GA, GN, GQ,
GW, ML, MR, NE, SN, TD, TG).

— before the expiration of the time limit for amending the
claims and to be republished in the event of receipt of
amendments (Rule 48.2(h))

Published:

— with international search report (Art. 21(3))

- 1 -

ROTARY FLUID MACHINE

Field of the Invention

- 5 The present invention relates to a rotary fluid machine, and in particular, but not exclusively to a rotary fluid machine that may be operated as either a pump or a motor.

Background of the Invention

- 10 One type of rotary fluid machine comprises a rotor and a stator which together defined a working chamber. A number of lobes are formed on one of the rotor and the stator, with a plurality of gates being supported by the other. Inlet and outlet ports are provided on opposite sides of each lobe to allow fluid to flow into and out of the working chamber. When the machine acts a motor, high pressure fluid is fed into the machine
15 and enters the working chamber through the inlet ports. The working chamber is divided into sub-chambers between adjacent gates. The fluid exerts pressure on the gates causing the rotor to rotate. As this rotation occurs, eventually the fluid in a sub chamber is brought into fluid communication with an outlet port and vented through the machine. While this is occurring, high pressure fluid continues to enter the working
20 chamber through the inlet ports and exerts pressure on other gates to maintain relative rotation between the rotor and stator.

- When used as a pump, another machine provides torque to the rotor to cause relative rotation between the rotor and stator. As this occurs, the gates displace fluid in the
25 pump forcing the fluid to flow through outlet ports and create a relative lower pressure state drawing further fluid through inlet ports into the working chamber.

- Numerous factors govern the efficiency and reliability of fluid rotary machines. Machine performance and reliability is also substantially affected by the nature of the
30 fluid passing through the machine. For example, fluids passing through the machine which contain abrasive products and/or corrosive substances are often problematic.

Summary of the Invention

- 35 In one aspect there is provided a rotary fluid machine comprising:
first and second bodies, the bodies being rotatable relative to each other and arranged one inside the other to define at least one working chamber there between;
at least one gate supported by the first body, each gate having: a planar axial surface and respective rounded corners at each end of the axial surface;
40 the second body comprising a circumferential surface forming a surface of the working chamber, the circumferential surface having an intermediate surface extending in an axial direction and contiguous curved surfaces on each side of the intermediate surface and extending in a radial direction to form with the intermediate surface a U

- 2 -

shaped channel, wherein when the planar axial surface is adjacent the intermediate surface, the rounded corners and the curved surfaces lie closely adjacent to and substantially parallel with each other.

5 In one embodiment each gate is arranged to cyclically extend from and retract into the first body in a radial direction as one body rotates relative to the other body.

In one embodiment each of the curved surfaces and the rounded corners smoothly curve through 90 degrees.

10

In one embodiment the rounded corners of the gate are convexly curved and the curved surfaces of the second body are concavely curved.

15 In one embodiment the second body comprises a stator of the machine and is rotationally fixed and the first body comprises a rotor of the machine and rotates relative to the stator.

In one embodiment the second body is disposed inside the first body.

20 In one embodiment the or each gate comprises a wiper and a gate seal system supported by the wiper, the gate seal system arranged to form a dynamic seal against the circumferential surface of the second body.

25 In one embodiment the wiper is provided with the planar axial surface and the respective rounded corners and the gate seal system comprises one or more sealing bands supported in the wiper and extendable from the planar axial surface and respective rounded corners.

30 In one embodiment the or each sealing band is resilient biased to extend from the planar axial surface and respective rounded corners.

In one embodiment the or each sealing band is axially and radially movable relative to the wiper.

35 In one embodiment each sealing band comprises a flexible strip of material.

40 In one embodiment each sealing band comprise a straight length and curved portions at each end of the straight length, and a plurality of slots formed in the curved portions to facilitate flexing of the curved portions in a plane containing a corresponding sealing band.

In one embodiment each sealing band comprise a plurality of slots formed in the straight length.

- 3 -

5 In one embodiment the gate seal system comprise at least two sealing bands juxtaposed face to face, each sealing band being provided with a plurality of slots to facilitate flexing of the sealing bands, and wherein the sealing bands and slots are arranged so that there is no direct fluid flow path between opposite sides of the gate seal system through the slots.

10 In one embodiment gate is provided with one or more radially extending channels to enable fluid flow between radially opposite ends of the gate.

In one embodiment the radially extending channels extend through the gate and open onto the radially opposite ends of the gate.

15 In one embodiment the radially extending channels are formed on one side surface of the gate.

In one embodiment the rotary fluid machine comprises a gate displacement system operable to displace the gate in a radial direction upon rotation of the first body relative to the second body.

20 In one embodiment the gate displacement system comprises for each gate, two gate links coupled one on each side of the gate, and cam surfaces arranged to guide the gate links to move in the radial direction as the first and second bodies rotate relative to each other, the gate links and the cam surfaces being disposed outside of the working chamber.

In one embodiment each gate link comprises two cam followers arranged to engage respective cam surfaces.

30 In one embodiment each gate link is slidably retained within the first body and coupled by a pin to a corresponding gate.

35 In one embodiment the first body comprises a radially extending pin slot for each pin, each pin extending axially through a corresponding pin slot to couple with a corresponding link, and a pin slot sealing arrangement operable to form a substantially seal about the pin slot.

40 In one embodiment each gate link comprises a leg coupled at one end to corresponding pin and wherein the cam followers are co-axially coupled near an opposite end of the leg.

- 4 -

In one embodiment the first body is provided with a link recess for each leg, each link recess being closed at one end and opened at an opposite end, wherein each leg is slidably retained in a respective link recess.

- 5 In one embodiment the cam surfaces comprise, on each side of the working chamber, first and second cam surfaces fixed to the second body and axially offset relative to each other.

10 In one embodiment the first body is provided with a link recess for each link, each link recess being formed inboard of a radially inner most and a radially outer most edge of the first body, wherein each link is slidably retained in a respective link recess.

In one embodiment two cam followers are rotatably coupled on respective axles on a same side of the link.

- 15 In one embodiment the pin slot sealing arrangement comprises first and second seal plates arranged face to face wherein the first seal plate is coupled to and moves with the link, the first seal plate further provided with a hole through which the pin extends; and the second seal plate is coupled to and fixed relative to the first body, the second seal plate being provided with a slot being in registration with a respective pin slot formed in the first body.

20 In one embodiment the cam surfaces comprise, on each side of the working chamber, opposite sides of a continuous cam rail.

- 25 In one embodiment the wherein the first body comprises an intermediate housing provided with a plurality of blind gate slots within which respective gates reciprocate.

30 In one embodiment the rotary fluid machine comprises first and second end caps coupled at axially opposite ends of the intermediate housing, wherein the gate links are disposed in the end caps.

35 In one embodiment the rotary fluid machine comprises a mechanical fluid seal on each side of the working chamber to provide a substantial fluid seal between the working chamber and the end caps.

40 In one embodiment the mechanical fluid seal comprises on each side of the working chamber a first ring fixed to first body and a second ring fixed to the second body, the rings being provided with polished surfaces biased into contact with each other.

In one embodiment the second body comprises one or more pairs of ports, each pair of ports comprising a fluid inlet port and a fluid outlet port and, one or more lobes demountable coupled to the second body and configured to project from the

- 5 -

circumferential surface of the second body, each lobe: located between the inlet and outlet ports in a pair of ports; and, comprising a central portion and at least one ramp extending from each side of the central portion to the circumferential surface, the at least one ramp having a ramp surface that provides a transition between the circumferential surface to an upper surface of the central portion.

In one embodiment the ports are provided with chamfered surfaces leading to the circumferential surface and the ramps seat on the chamfered surfaces.

10 In one embodiment each lobe comprises two ramps extending from each side of the central portion.

In one embodiment the central portion and the ramps are formed as separate parts and interfitted with each other when a corresponding lode is coupled to the body.

15 In one embodiment the central portion extends in an axial direction across the circumferential surface.

20 In one embodiment the lobes are disposed in an axial direction between the contiguous curved surfaces.

In one embodiment the rotary fluid machine comprises a coupling mechanism for demountably coupling each of the lobes to the body, the coupling mechanism comprising a locking member that engages a corresponding lobe at a location radially inside of the circumferential surface.

In one embodiment each lobe comprises one or more lugs extending in a radial inward direction and configured for engagement with the locking member.

30 In one embodiment wherein each gate slot comprises two spaced apart and parallel flat surfaces which face each other and extend at one end to an inner circumferential surface of the intermediate housing, and a contiguous arcuate portion extending between respective distant ends of the flat surfaces forming a blind end of the gate slot.

35 In one embodiment the contiguous arcuate surface has a diameter greater than a transverse distance between the flat surfaces.

In one embodiment the flat surfaces are separated by a transverse distance W and the arcuate portion has a diameter D and $W \leq D \leq 5W$.

40 In a second aspect the invention provides a body for a fluid rotary machine, the body comprising:

- 6 -

one or more pairs of ports, each pair of ports comprising a fluid inlet port and a fluid outlet port; and,

5 one or more lobes demountable coupled to the body and configured to project from a circumferential surface of the body, each lobe: being located between the inlet and outlet ports in a pair of ports; and, comprising a central portion and at least one ramp extending from each side of the central portion to the circumferential surface, the at least one ramp having a ramp surface that provides a transition between the circumferential surface to an upper surface of the central portion.

10 In one embodiment portions of the circumferential surface of the body on either side of a lobe have a constant radius.

In one embodiment a portion of the circumferential surface underlying the central portion is flat.

15 In one embodiment the ports are provided with chamfered surfaces leading to the circumferential surface and the at one ramps seat on the chamfered surfaces.

20 In one embodiment each lobe comprises two ramps extending from one side of the central portion and two ramps extending from an opposite side of the central portion.

In one embodiment respective ramps bridge across the inlet and outlet ports in a pair of ports.

25 In one embodiment the central portion and the ramps are formed as separate parts and interfitted with each other when a corresponding lobe is coupled to the body.

In one embodiment the central portion extends in an axial direction across the circumferential surface.

30 In one embodiment the upper surface of central portion is a continuous surface.

35 In one embodiment the circumferential surface of the body comprises an intermediate surface extending in an axial direction and contiguous curved surfaces, one on each side of the intermediate surface and extending in a radial direction, and wherein the lobes are disposed in an axial direction between the contiguous curved surfaces.

In one embodiment the contiguous curved surfaces are provided on flanges extending radially of and about the body.

40 In one embodiment the continuous surface on the central portion has a curvature the same as that of an outer circumferential surface of the flanges.

- 7 -

In one embodiment the body comprises a coupling mechanism for demountably coupling each of the lobes to the body, the coupling mechanism comprising a locking member that engages a corresponding lobe at a location radially inside of the circumferential surface.

5

In one embodiment each lobe comprises one or more lugs extending in a radial inward direction and configured for engagement with the locking member.

10 In one embodiment each lug comprises a hole through which the locking member passes to engage the lobe.

In a third aspect the invention provides a rotary fluid machine comprising:

a first body;

15 a second body comprising the body accordance with the second aspect, the first and second bodies being rotatable relative to each other and arranged one inside the other to define at least one working chamber there between; and,

at least one gate, the or each gate movable within respective gate slots formed in the first body, each gate being movable to wipe across the circumferential surface of the second body and the lobes when the bodies rotate relative to each other.

20

In one embodiment the second body is a stator of the machine and lies inside of the first body.

25 In one embodiment each gate comprises a planar axial surface and respective rounded corners at each end of the planar axial surface and wherein when the planar axial surface is adjacent the intermediate surface, the rounded corners and the curved surfaces lie closely adjacent to and substantially parallel with each other.

30 In a fourth aspect the invention provides a body for a fluid rotary machine, the body forming a rotor or a stator of the machine and comprising:

35 one or more radially extending blind gate slots that open onto a circumferential surface of the body, each gate slot having two spaced apart and parallel flat surfaces which face each other and extend at one end to the circumferential surface and a contiguous arcuate portion extending between respective distant ends of the flat surfaces forming a blind end of the gate slot.

In one embodiment the contiguous arcuate surface has a diameter greater than a transverse distance between the flat surfaces.

40 In one embodiment the flat surfaces are separated by a transverse distance W and the arcuate portion has a diameter D and $W \leq D \leq 5W$.

- 8 -

In one embodiment the body comprises: an intermediate housing provided with the blind gate slots; and, two face plates one disposed on either side of the intermediate housing, each face plate provided with a plurality of pin slots formed inboard of radial inner and radial outer edges of the face plates and passing through a thickness of the face plates, the pin slots in the face plates positioned to register with the blind slots in the intermediate housing.

In one embodiment each face plate is provided with a plurality of seals, each seal circumscribing a corresponding pin slot in the face plate on a side distant the intermediate housing.

In one embodiment the body comprises two end caps, one adjacent each face plate, and wherein an outer circumferential surface of the face plates is located radially inward of respective outer circumferential surfaces of the intermediate housing and the end caps.

In one embodiment wherein each end cap is provided with a plurality of radially extending link recesses on a side adjacent the face plates, the radially extending link recesses being closed at a radial outer end and open at a radial inner end.

In one embodiment the body comprises an intermediate housing provided with the blind gate slots and first and second end caps coupled at axially opposite ends to the intermediate housing, each end cap being provided a plurality of link recesses formed inboard of a radially inner most and a radially outer most edge of a corresponding end cap.

In one embodiment each end cap is provided with a plurality of pin slots formed inboard of radial inner and radial outer edges of a corresponding end cap, the pin slots in the end caps positioned to register with the blind slots in the intermediate housing and opening onto respective link recesses.

In one embodiment the body comprises a respective sealing arrangement associate with each link recess and respective pin slot, each sealing arrangement comprising first and second seal plates arranged face to face wherein the first seal plate arranged to move within a corresponding link recess, the first seal plate further provided with a through hole configured to receive a pin, and the second seal plate is fixed within the corresponding link recess, the second seal plate being provided with a slot in registration with a respective pin slot of the corresponding link recess.

In a fifth aspect the invention provides a rotary fluid machine comprising:
first and second bodies, the first body being provided with one or more radial gate slots, the bodies being rotatable relative to each other and arranged one inside the other to define there between: at least one working chamber;

- 9 -

at least one gate movable in a radial direction within a respective radial gate slot; and,

5 a gate displacement mechanism operable to displace the or each gate in a radial direction within a corresponding gate slot upon rotation of the first body relative to the second body;

10 wherein the gate displacement mechanism comprises, for each gate: two gate links coupled one on each side of the gate; and, cam surfaces arranged to guide the gate links to move in the radial direction as the first and second bodies rotate relative to each other, the gate links and the cam surfaces being disposed outside of the working chamber.

In one embodiment each gate link comprises two cam followers arranged to engage respective cam surfaces.

15 In one embodiment each gate link is slidably retained within the first body and coupled by a pin to a corresponding gate.

20 In one embodiment the first body comprises a radially extending pin slot for each pin, each pin extending axially through a corresponding pin slot to couple with a corresponding link, and a sealing arrangement operable to form a substantially seal about the pin slot.

25 In one embodiment each gate link comprises a leg coupled at one end to corresponding pin and wherein the cam followers are co-axially coupled near an opposite end of the leg.

30 In one embodiment the first body is provided with a link recess for each leg, each link recess being closed at one end and opened at an opposite end, wherein each leg is slidably retained in a respective link recess.

In one embodiment the cam surfaces comprise, on each side of the working chamber, first and second cam surfaces fixed to the second body and axially offset relative to each other.

35 In one embodiment the first body is provided with a link recess for each link, each link recess being formed inboard of a radially inner most and a radially outer most edge of the first body, wherein each link is slidably retained in a respective link recess.

40 In one embodiment two cam followers are rotatable coupled on respective axles on a same side of the link.

In one embodiment the sealing arrangement comprises first and second seal plates arranged face to face wherein a the first seal plate is coupled to and moves with the

- 10 -

link, the first seal plate further provided with a hole through which the pin extends; and a the second seal plate is coupled to and fixed relative to the first body, the second seal plate being provided with a slot being in registration with a respective pin slot formed in the first body.

5

In one embodiment the cam surfaces comprise, on each side of the working chamber, opposite sides of a continuous cam rail.

10

In one embodiment the first body comprises an intermediate housing provided with the one or more gate slots.

15

In one embodiment the rotary fluid machine comprises first and second end caps coupled at axially opposite ends of the intermediate housing, wherein the gate links are disposed in the end caps.

20

In one embodiment the rotary fluid machine comprises a mechanical fluid seal on each side of the working chamber to provide a substantial fluid seal between the working chamber and the end caps.

25

In one embodiment the mechanical fluid seal comprises on each side of the working chamber a first ring fixed to first body and a second ring fixed to the second body, the ring provided with polished surfaces biased into contact with each other.

30

In a sixth aspect the invention provides a gate for a rotary fluid machine having first and second bodies, the first body being provided with one or more radial gate slots, the bodies being rotatable relative to each other and arranged one inside the other to define a working chamber there between, the working chamber having a circumferential surface, the gate comprising:

a wiper and a sealing system supported by the wiper and arranged to form a dynamic seal against the circumferential surface of the second body.

35

In one embodiment the wiper is provided with a planar axial surface and respective rounded corners at opposite ends of the planar axial surface and the sealing system comprises one or more sealing bands supported in the wiper and extendable from the planar axial surface and respective rounded corners.

40

In one embodiment the or each sealing band is resilient biased to extend from the planar axial surface and respective rounded corners.

In one embodiment the or each sealing band is axially and radially movable relative to the wiper.

In one embodiment each sealing band comprises a flexible strip of material.

- 11 -

5 In one embodiment each sealing band comprise a straight length and curved portions at each end of the straight length, and a plurality of slots formed in the curved portions to facilitate flexing of the curved portions in a plane containing a corresponding sealing band.

In one embodiment each sealing band comprises a plurality of slots formed in the straight length.

10 In one embodiment the sealing system comprise at least two sealing bands juxtaposed face to face, each sealing band being provided with a plurality of slots to facilitate flexing of the sealing bands, and wherein the sealing bands and slots are arranged so that there is no direct fluid flow path between opposite sides of the sealing system through the slots.

15 In one embodiment each gate is provided with one or more radially extending channels to enable fluid flow between radially opposite ends of the gate.

20 In one embodiment the radially extending channels extend through the gate and open onto the radially opposite ends of the gate.

In one embodiment the radially extending channels are formed on one side surface of the gate.

25 In a seventh aspect the invention provides a rotary fluid machine comprising:
first and second bodies, the first body being provided with one or more radial slots, the bodies being rotatable relative to each other and arranged one inside the other to define a working chamber there between;
at least one gate movable in a radial direction within a respective radial slot,
30 each gate having a wiper disposed in the working chamber and being supported at opposite ends on respective lifters, each lifter disposed outside, and on mutually opposite sides, of the working chamber; and arranged to cooperate with one or more cam surfaces to effect reciprocating radial motion of a corresponding the gate in an associated slot; and
35 a fluid sealing system providing a fluid seal between the working chamber and the cam surfaces.

Brief Description of the Drawings

40 Embodiments of the present invention will now be described by way of example only with reference to the accompanying drawings in which:

Figure 1 is a partial cut away view of an embodiment of the machine in accordance

- 12 -

with the present invention;

Figure 2 is a radial section view of the machine shown in Figure 1;

Figure 3 is an axial cross section view of the machine shown in Figure 1;

5 Figure 4 is an isometric view of a stator incorporated in the machine shown in Figures 1 – 3;

Figure 5 is a side view of the stator shown in Figure 4;

Figure 6a – 6f are views from alternate angles and ends of a manifold incorporated in the machine shown in Figure 1;

10 Figure 7a is a perspective view from a first angle of a demountable lobe incorporated in the machine shown in Figure 1;

Figure 7b is a further isometric view of the lobe shown in Figure 7a but from an alternate angle;

Figure 8a – 8e are views from alternate angles of a cam ring incorporated in the machine shown in Figure 1;

15 Figures 9a – 9c are isometric views from alternate angles of a cam shoe incorporated in the machine shown in Figure 1;

Figure 10 is a perspective view of the gate assembly incorporated in the machine shown in Figure 1;

20 Figure 11a is a perspective view of an intermediate housing incorporated in the machine;

Figure 11b is an elevation view of the intermediate housing shown in Figure 11a;

Figure 11c is an enlarged view of a portion of the intermediate housing and stator showing a configuration of a gate slot;

25 Figure 11d is an enlarged view of a portion of the intermediate housing and stator showing an alternate configuration of a gate slot;

Figures 12a – 12c provide alternate views of a face plate incorporated in the machine;

Figures 13a – 13e illustrate from alternate angles, an end cap incorporated in the machine;

30 Figure 14 is a schematic representation of a sealing and pressure equalisation arrangement that may be incorporated in an embodiment of the machine;

Figure 15 is a schematic representation of a possible arrangement for construction of a portion of a gate displacement mechanism incorporated in the machine;

Figure 16 is a cut away schematic representation of a second embodiment of a machine in accordance with the present invention;

35 Figure 17a is an exploded view of the machine shown in Figure 16;

Figure 17b is a further exploded view of the machine shown in Figure 16 but showing the stator and some associated components in greater detail;

Figure 18a is a partially exploded view of an integrated end cap incorporated in the second embodiment of the machine shown in Figure 16;

40 Figure 18b is a view of a section through a diameter of the integrated end cap shown in Figure 18a;

Figure 19a is a section view of the second embodiment of the machine;

Figure 19b is a view of detail A of Figure 19a;

- 13 -

- Figure 19c is a view of detail B of Figure 19a;
- Figure 20a is an isometric view of a gate incorporated in the machine shown in Figure 16;
- Figure 20b is a side elevation view of the gate shown in Figure 20a;
- 5 Figure 20c is a bottom elevation of the gate shown in Figure 20a;
- Figure 20d is a top elevation of the gate shown in Figure 20a;
- Figure 20e is a side elevation of the gate shown in Figure 20a;
- Figure 21a is an isometric view of a sealing strip incorporated in the machine shown in Figure 16;
- 10 Figure 21b is a front elevation of the sealing strip shown in Figure 21a;
- Figure 22a is an enlarged portion of the machine shown in Figure 16 depicting its gate in an inactive position;
- Figure 22b is a view of the portion of the machine shown in Figure 22a but with the gate in an active position;
- 15 Figure 23a is an isometric view of a lobe incorporated in the machine shown in Figure 16;
- Figure 23b is an isometric view of a central portion of the lobe shown in Figure 23a;
- Figure 23c is an isometric view of an arm incorporated in lobe shown in Figure 23a;
- Figure 24a is an isometric view of a stator of the machine shown in Figure 16 with a fitted lobe;
- 20 Figure 24b is an isometric view of the stator shown in Figure 24a but with the lobe removed;
- Figure 25a is an exploded view of an alternate form of gate that may be incorporated in other embodiments of the machine;
- 25 Figure 25b is a side view of the gate shown in Figure 25a;
- Figure 25c is an isometric view of the gate shown in Figure 25a;
- Figure 26a is an enlarged view of a portion of an embodiment of the machine incorporating the gate shown in Figure 25a when in an inactive position; and,
- Figure 26b is a view of the portion of the machine shown in Figure 26a but with the gate now in an active position.
- 30

Detailed Description of the Preferred Embodiments

- Referring to the accompanying drawings and in particular Figures 1 – 3, an
- 35 embodiment of a rotary fluid machine 10 comprises a first body 12, a second body 14, and a plurality of gates 16a -16f (hereinafter referred to in general as "gate(s) 16"). In this embodiment, the first body 12 is a rotor while the second body 14 is a stator. The rotor 12 and stator 14 are rotatable relative to each other and arranged one inside the other to define a working chamber 18 there between. Gates 16 are supported in radial
- 40 gate slots 20 formed in the rotor 12 and cyclically extend from and retract into the gate slots 20 as the rotor 12 rotates about stator 14. A plurality of demountable lobes 22a – 22c (hereinafter referred to in general as "lobe(s) 22") is supported on an outer circumferential surface 24 of stator 14. The surface 24 forms a surface of the working

- 14 -

chamber 18. As rotor 12 rotates the gates 16 wipe across the outer circumferential surface 24 and lobes 22. This causes displacement of fluid through the working chamber 18 and machine 10.

5 Fluid is directed through the machine 10 via: a central conduit 26 which forms part of the stator 14; a manifold 28 disposed in the conduit 26; and, a plurality of inlet ports 30a, 30b, 30c (hereinafter referred to in general as "inlet port(s) 30") and outlet ports 32a, 32b, 32c (hereinafter referred to in general as "outlet port(s) 32") provided in stator 14. The gates 16 and lobes 22 are arranged so that at any one time one gate 16 is
10 wiping across the stator 14 at a location between an inlet port 30 and an outlet port 32 located between pairs of adjacent lobes 22. This results in a division of the working chamber 18 into alternating inlet and outlet chambers 34 and 36 respectively.

15 Flow of fluid through the machine 10 is essentially axial. In this regard fluid enters the machine 10 through an inlet end 38 of conduit 26, and is uniformly divided by manifold 28 to provide substantially equal fluid flows in terms of pressure and volume into each of the inlet ports 30. This fluid then flows into the corresponding inlet chambers 34. Assuming that the machine 10 is being operated as a motor, the fluid entering inlet end 38 is at a relative high pressure. This fluid flows into the inlet chambers 34 and acts
20 against the gates 16. The outlet chambers 36 on an opposite side of each of gate 16 are vented via outlet ports 32 to a relative low pressure. Accordingly a pressure differential exists across adjacent inlet and outlet chambers 34 and 36. This causes rotation of rotor 12 in (with reference to Figure 2) an anti-clockwise direction about stator 14. Hose couplings C1 and C2 are screwed into the inlet 38 and outlet 40 to
25 facilitate attachment of fluid hoses (not shown) to the machine 10.

To assist in describing the operation of the machine 10 consider, with reference to Figure 2 a high pressure fluid flowing through inlet port 30a into the chamber 34 and acting on gate 16b. The pressure differential across gate 16b causes rotor 12 to rotate
30 in an anti-clockwise direction moving gate 16b toward outlet port 32a. Thus fluid in advance of gate 16b is vented to the outlet port 32a. Simultaneously gate 16a is rotated toward and indeed past inlet port 30b. By the time gate 16b passes outlet port 32a the gate 16a has been rotated past inlet port 30a. Thus high pressure fluid is now able to act on gate 16a to continue the rotation of rotor 12 while fluid in between gate
35 16a and 16b flows through outlet port 32a.

The above describes the general operation of machine 10 as a motor. Machine 10 is able to operate as a pump by applying torque to the rotor 12 causing it to rotate relative
40 to stator 14.

Each of the components, structures and systems of machine 10 will now be described in greater detail starting with the stator 14. With particular reference to Figures 4 and 5, stator 14 comprises a hub 42 formed coaxial with the central conduit 26. The outer

- 15 -

circumferential surface 24, inlet ports 30 and outlet ports 32 are formed on or in the hub 42. The inlet and outlet ports 30, 32 extend radially and open onto both the circumferential surface 24, and an inner circumferential surface 44 of the conduit 26. Circumferential surface 24 comprises an intermediate surface 48 which extends in an axial direction and opposite curved surfaces 46. Surfaces 46 are concavely curved and extend away from intermediate surface 48. In cross-section, the circumferential surface 24 forms a wide and relatively shallow U shaped channel with the intermediate surface 48 forming a planar bottom of the U shaped channel and the curved surfaces 46 forming rounded corners and arms of the U shaped channel, as seen most clearly in Figure 5.

The curved surfaces 46 are formed on axial inner surfaces of respective radially extending flanges 50. The flanges 50 delimit the axial extent of hub 42. A planar surface 52 is provided on a side of each flange 50 opposite its curved surface 46. A circumferential surface 53 of constant diameter extends about each flange 50 between the curved surface 46 and the planar surface 52.

The intermediate surface 48 is of constant outer diameter between the lobes 22. However surface 48 includes a number of flat lands 54 on which the lobes are mounted. An inlet port 30 is disposed immediately adjacent one side of a corresponding land 54 with an outlet port 32 immediately adjacent an opposite side that land 54. Each land extends in an axial direction between the curved surfaces 46 and is provided with a number of radial inwardly extending holes 56.

Each inlet port 30 has an opening provided with one edge 58 forming a common edge with an adjacent land 54, and an opposite edge 60 opening onto the surface 24. The opening of port 30 adjacent edge 60 is formed with chamfered or bevelled surface 62 that slopes from the edge 60 radially inward toward the adjacent land 54.

Each outlet port 32 is also provided with an opening having a common edge 64 with land 54, and an opposite edge 66 opening onto the surface 48. A chamfered or bevelled surface 68 extends from edge 66 in a radially inward direction toward land 54.

A plurality of evenly spaced seats 70 is formed on an outer circumferential surface 71 of conduit 26 on opposite sides of hub 42. As will be explained in greater detail below, seats 70 are arranged to receive cam surfaces for operating the gates 16.

Flow of fluid through machine 10 is distributed or controlled by the manifold 28 which is installed inside conduit 26. Figures 6a – 6f illustrate one possible form of manifold 28. The manifold 28 is in the form of a solid billet of material having three inlet flutes 72 and three outlet flutes 74. Each of the inlet flutes 72 is of the same shape and configuration and is provided at an axial outer end with an arcuate edge 73 extending for 120°. The flutes 72 reduce in cross-sectional area in a downstream direction D. An axial inward

- 16 -

end 76 of each flute 72 is located immediately below a corresponding inlet port 30. The ends 76 lead to an outer circumferential surface 78 of the manifold 28 which is in sealing contact with the inner circumferential surface 44 of conduit 26.

- 5 The outlet flutes 74 are of identical shape and configuration to the inlet flutes 72 and are circumferentially interleaved with flutes 72. However the outlet flutes 74 are in a reverse orientation so that they increase in cross-sectional area in the downstream direction D from their respective axial inward ends 80 to an arcuate axial outer ends which terminate in arcuate edges 82 extending for 120°. Further the axial inward end
10 80 of each outlet flute 74 is located immediately below a corresponding outlet port 32.

- The lobes 22 are shown coupled with stator 14 in Figures 1, 2 and 3; and, as individual components in Figures 7a and 7b. Each lobe 22 comprises a central portion 84 and, in this instance, two ramps or legs 86 which extend from each side of central portion 84.
15 As shown in Figures 1 and 2, the ramps 86 extend across ports 30 and 32 on either side of a land 56. A surface 88 at a free end of each of the ramps 86 is bevelled or chamfered at a corresponding angle to the chamfered surfaces 60 and 68. Central portion 84 is formed with upper and lower surfaces 90 and 92. Upper surface 90 has the same curvature as the outer circumferential surface 53 on flanges 50. Arcuate end
20 surfaces 96 extend between the upper and lower surfaces 90 and 92. The arcuate surfaces 96 are of a radius substantially the same as the radius of curvature of the curved surfaces 46. Three lugs 94 depend at right angles from surface 92. Mutually aligned holes 97 are formed in the lugs 94

- 25 Lobes 22 are demountably coupled to the stator 14 by inserting the lugs 94 into the holes 56 of respective lands 54. The planar surface 92 sits on the land 54 and the ramps 86 extend across adjacent ports 30 and 32 with the surfaces 88 abutting corresponding chamfered surface 60 or 68 of respective inlet port 30 or outlet port 32. An upper surface 98 of each ramp 86 is smoothly curved and extends from the
30 intermediate surface 48 to the upper surface 90. Thus when a gate 16 wipes across the outer circumferential surface 24 there is a smooth transition between the intermediate surface 48 and lobes 22.

- The lobes 22 are held in place by a mechanical locking device such as a pin that
35 extends through a corresponding axial hole 100 (see Fig. 4) formed through the hub 42. Thus, the pin engages the lobe 22 at a location radially inside of the circumferential surface 24 and outside of the working chamber. As a result of this the pin is not exposed to or contacted by the gates 16 or the fluid in the machine 10.

- 40 The gates 16 are operated external to the working chamber 18 by cam surfaces 102 and 104 (see Figures 1, 8a-9c) provided on each side of the working chamber 18 and coupled to the stator 14. In this embodiment the cam surfaces 102 and 104 on each side of the working chamber 18 are radially spaced from each other. The cam surface

- 17 -

102 is formed as an inner circumferential surface of a cam ring 106. The cam ring 106 is shown by itself in Figures 8a-8e and attached to stator 14 in Figure 1. Each cam ring 106 has an outer circumferential surface 108 of constant diameter and a radial face 110 provided with a number of holes 112 to enable coupling of the rings 106 to the planar surfaces 52 of flanges 50. As shown in Figures 8d and 8e, a small bevelled edge 114 is formed about cam ring 106 adjacent outer circumferential surface 108 on a side opposite radial face 110

The cam surface 104 comprises the combination of: a surface 116 on each of a plurality of cam shoes 118 fixed to the stator 14; and, intervening circumferential bands 123 of the surface of the stator 14. Figure 1 illustrates a cam shoe 118 coupled to the stator 14 while Figures 9a-9c illustrate the cam shoe 118 by itself. Each cam shoe 118 comprises a curved base 120 configured to seat on a corresponding land 70 formed on a stator 14, and an upstanding tongue 122. The surface 116 is the radial outermost surface of tongue 122 and comprises two outer concavely curved portions 117a and an intermediate convexly curved portion 117b. The convexly curved portion has a planar plateau 117c. The surfaces 116 are in axial and radial alignment with the inlet and outlet ports 30 and 32 adjacent a common lobe 22. In this instance, as there are three lobes 22 there are also three shoes 118 demountably fixed to the conduit 26 on each side of the working chamber 18. The cam surfaces 102 and 104 control the extension and retraction of gates 16 from and into their respective slots 20.

Figures 1 and 3 illustrate the gates 16 coupled with an associated displacement mechanisms 125 in situ in machine 10, while Figure 10 illustrates a gate 16 and an associated displacement mechanism 125 by themselves. The gate displacement mechanism is operable to reciprocate the gates 16 along a radius of the machine 10. The gate 16 comprises a wiper or blade 124 configured to run with limited clearance to the circumferential surface 24 in working chamber 18. The displacement mechanism 125 comprises pins 126 extending from each end of wiper 124, and a link 128 attached to each pin 126. As shown in Figures 1 and 3, the links 128 are disposed outside of and on axially opposite sides of the working chamber 18. Further each link 128 is acted upon by the cam surfaces 102 and 104 on each side of working chamber 18.

Wiper 124 has opposite curved surfaces 130 separated by an axial planar surface 132. The curved surfaces 130 extend to a planar radial surface 134 and form rounded corners of the wiper 124. The shape and configuration of the gate 16 and corresponding wiper 124 is made to match that of the outer circumferential surface 24 so that when the axial surface 132 lies substantially adjacent and parallel to intermediate surface 48 each of the curved surfaces 130 lie closely adjacent to and substantially parallel with the concavely curved surfaces 46. Stated another way the rounded corners of the gate 16 and wiper 124 nest in the curved surfaces 46. A small tolerance gap is provided between the surfaces of the gate 16 and the circumferential surface 24 to prevent face to face contact between the gates 16 and the stator 14. A

- 18 -

plurality of radially extending channels 135 is formed in gate 16 to allow fluid flow between radially opposite sides of the wiper 124 as the gate 16 reciprocates within its respective gate slots 20. In this embodiment the channels 135 allow fluid to flow through the wiper 124. However in later described embodiments the channels 135 are
5 formed on a face of the wiper to allow fluid to flow past or over that face.

Each link 128 comprises a leg 136 with cam followers in the form of respective rollers 138 and 140 at a radial inner end; and a radial outer face 141. In this embodiment, rollers 138 and 140 are coaxially supported but independently rotatable. In the
10 assembled machine 10, rollers 138 are acted upon by the cam surface 102 of cam ring 106, while rollers 140 are acted upon by cam surface 104. The cam surfaces 102 and 104 cooperate to form a cam track 141 (see Fig. 1) for the rollers 138 and 140. As rotor 12 rotates relative to the stator 14, the rollers 138 and 140, and thus the displacement mechanism 125, are guided by the cam surfaces 102 and 104 to extend
15 or retract the corresponding gates 16 from or into respective slots 20 to maintain the axial edge 132 of wiper 124/gate 16 close to the circumferential surface 24 leaving only the tolerance gap there between.

The rotor 12 comprises an assembly of components including a central or intermediate housing 142, face plates 144 disposed on either side of the intermediate housing 142, and end caps 146 disposed adjacent each of the face plates 144. These components are shown in an assembled state forming the rotor 12 in Figure 1, and individually in
20 Figures 11a-13d.

With reference to Figures 1, 11a and 11b intermediate housing 142 is in the form of an annulus having a radial inner portion 154 and a contiguous radial outer band 156. The inner portion 154 of the housing has a smooth inner circumferential surface 148 of constant diameter segmented by the gate slots 20. The outer circumferential surface 150 on the outer band 156 is formed with axially extending teeth 152. In use, the teeth
25 152 enable coupling of the rotor 14 via for example a toothed belt to another device or machine to enable transfer of torque.

The outer band 156 over-hangs the inner radial portion 154 by equal amounts on opposite sides creating a circumferential stepped shoulder 157 on either side of
35 housing 142. The shoulders 157 lead to planar radial faces 158 of the radial inner portion each 154.

The gate slots 20 have a depth S and are formed in the radial inner portion 154 at evenly spaced locations opening onto the inner circumferential surface 148. Each gate
40 slot 20 also opens onto each of the radial faces 158 at opposite axial ends, but is closed at its radial outer end 160. Starting from the inner circumferential surface 148, each gate slot 20 comprises a pair of parallel spaced apart planar walls 162 which extend in a radial direction toward the teeth 152, and terminate in a contiguous arcuate

- 19 -

portion 164 which extends between the radial outer edges of walls 162. The arcuate portion is wholly within the body of the intermediate housing 142 and thus the gate slots are blind gate slots. The provision of the arcuate portion 164 markedly reduces stress concentration in the gate slots 20 enabling the intermediate housing 142 to be made of a much smaller diameter than that with a square ended slot for the same load/pressure rating.

Figures 11c and 11d illustrate two possible gate slot configurations when the arcuate portion 164 is in the general shape of a circle. In each of these Figures:

- 10 L: is the lift of a gate 16 which is equal to the difference between the radius of surface 148 of intermediate housing 142 and the radius of surface 48 of stator 14;
- 15 W: is the transverse distance between walls 162;
- X: is the radial length of a wall 162;
- 20 D: is the diameter of the arcuate portion 164; and,
- S: is the total radial length, or depth of a slot 20.

In both configurations $S \approx 2L$. However it is believed that in various embodiments the slot depth may be in the range of $2L < S \leq 2.5L$. In the embodiment shown in Figure 11c the diameter D of the arcuate portion 164 is the same as the slot width W. In the embodiment shown in Figure 11d the diameter D is several times the width W. It is envisaged that for some embodiments of the machine 10 the relationship between diameter D and width W may vary in accordance with: $W \leq D \leq 5W$.

30 The diameter D is dependent on the magnitude of material strain of the rotor 12 and slot width W. The magnitude of material strain is dependent on gauge pressure and strength of material used. So generally, assuming material strain and W are constant: if gauge pressure increases then diameter D must increase; alternately if gauge pressure decreases, D is able to decrease to a minimum of W.

35 Consider the scenario where W is allowed to be variable and gauge pressure and material strain remain constant. The following would hold true: as W increases, D must increase; and, as W decreases, D can decrease.

40 Slot width W is also dependent on magnitude of material strain, therefore strength of material used and fluid pressure (i.e. the differential pressure between inlet and outlet working chambers). W is also dependent on gate lift L. So generally, when holding material strain constant: as the differential pressure increases, W must increase and/or

- 20 -

L must decrease; and as the differential pressure decreases, W can decrease and/or L can increase.

5 With reference to Figures 1 and 12a-12c, each face plate 144 is in the form of a relatively thin annular disc provided with opposite radial faces 168 and 170; an inner circumferential surface 179 and outer circumferential surface 180. Face 170 is recessed forming an inner shoulder 172 and mutually contiguous inner radial face 173 and intermediate circumferential face 175. Six radially extending pin slots 174 formed through the face plates 144. The location of the pin slots 174 coincides with the
10 location of gate slots 20 in the intermediate housing 142. A groove 176 is formed about each of the slots 174 on face 168 for seating respective seals (not shown). A plurality of fastener holes 178 is formed in face plate 144 at locations which register with the holes 166 in intermediate housing 142.

15 With reference to Figure 1, in the assembled rotor 12, the outer circumferential surface 180 of the face plates 144 sit in the circumferential shoulders 157 on each side of intermediate housing 142; while each flange 50 of the stator 14 is received in the inner shoulder 172. This results in the surfaces 173 and 175 being in facing relationship with surfaces 52 and 53 respectively of flange 50.

20 Each end cap 146 shown in Figures 1 and 13a-13d is in the form of an annulus having an outer circumferential band 182 provided with axially extending teeth 184 of the same shape and configuration as teeth 152 on the intermediate housing 142. On an axial inner side 186 the band 182 extends beyond a radial face 188 of end cap 146.
25 This creates a circumferential shoulder 190 between the face 188 and the band 182. Moving in a radial inward direction from face 188, there is a further stepped recess in end cap 146 creating an inner circumferential surface 191 and an adjacent radial inward directed flange 192 having a radial surface 193.

30 With reference to Figures 13b and 13d, it can be seen that on an axial outer side 194 of cap 146 there is a planar radial surface 196 which is co-planar with the axial extent of the outer circumferential band 182. Moving in a radially inward direction along surface 196, there is a stepped recess 197 forming an inner circumferential surface 198 and an outer face 200 of the flange 192.

35 A plurality of evenly spaced radially extending link recesses 202 is formed in the inner face 188 and partially into adjacent portion of outer band 182. The link recesses 202 register with the pin slots 174 and blind gate slots 20 in the assembled rotor 12. Each link recess 202 opens at its radial inner end on to the surface 191, and has a radial
40 face 203. The link recesses 202 are configured to receive the links 128 of the gates 16 so that the legs 136 of links 128 can slide in a radial direction within link recesses 202. In one embodiment the legs 136 and link recesses 202 are relatively dimensioned so

- 21 -

that the radial outer face 141 of each leg is spaced from the radial face 203 of a corresponding link recess 202.

5 When the rotor 12 is assembled, the end caps 146 are orientated so that their radial faces 188 are innermost and face surfaces 168 of respective adjacent face plates 144. Face plate 144 is seated in the shoulder 190 and the teeth 184 axially align with the teeth 152 in the intermediate housing 142. The surface 191 and radial adjacent face 193 of flange 192 creates a recess or space 199 (see Figure 1) with the stator 14 within which are disposed the cam surfaces 102 and 104, and the rollers 138 and 140 of the links 128. The recess 197 of each end cap 146 seat respective bearings 210 which in turn are press fit onto opposite ends the conduit 26 of stator 14.

15 A sealing system is provided to substantially seal the recess 199 which contains the cam surfaces 102, 104 and the cam followers or rollers 138 and 140; from the working chamber 18. The sealing system also seals the bearing 210 from the fluid flowing through the machine. 10. Accordingly portions of the machine 10 that are in physical contact with each other when the machine is in operation (i.e. the cams and cam followers) are isolated from fluid passing through the machine 10. As the fluid may include abrasive particles and/or corrosive substances, this greatly enhances the reliability of the machine 10. It also enables machine 10 to be made with closer tolerances and operate at higher pressures.

25 The working chamber 18 is bound by the following surfaces: intermediate surfaces 48, opposite radial curved surfaces 46, and inner circumferential surface 148 of the intermediate housing 142. Fluid leakage paths from the chamber 18 may exist: through the slots 20 and 174; the interface between facing surfaces of flanges 50 seated in the shoulder 172 of the face plates 144, and the interface between the inner circumferential surface of the face plates 144 and the outer circumferential surface 108 of the cam rings 106.

30 The sealing system incorporated in machine 10 operates to prevent or minimize fluid leakage through one or more of the above mentioned leakage paths. To this end, the sealing system incorporates a number of static and dynamic seals or sealing systems. One of these is comprised of ring seals (not shown) seated in each of the grooves 176 circumscribing the pin slots 174 in face plates 144.

35 A first rotary seal 214 is provided between surface 52 of each flange 50 and surface 173 of an adjacent face plate 144. A further rotary seal 216 may be provided between the outer circumferential surface 53 and circumferential face 175 in recess 172 of each face plate 144. A further rotary seal 218 may be provided between the outer circumferential surface 108 of the cam ring 106 and inner circumferential surface 179 of face plate 144.

- 22 -

As previously described, machine 10 may operate as a motor or a pump. Further, the machine 10 is bidirectional in that it can operate with the rotor 12 rotating either clockwise or anticlockwise relative to the stator 14. This naturally however changes the direction of flow of fluid through the machine 10. When machine 10 is operated as a motor with high pressure fluid entering from inlet end 38 of conduit 26, the fluid is diverted by manifold 28 into each of the inlet ports 30. The fluid then flows into a corresponding inlet chamber 34 and acts against the gate 16 causing rotor 12 to rotate about the stator 14. As the rotor 12 rotates, the gates 16 are mechanically extended from or retracted into their slots 20 by the action of the cam surfaces 102 and 104 and the cam followers/rollers 138 and 140.

The contacting cam surfaces and cam followers within the space 199 are sealed from the working chamber 18 by action of the sealing system described above. The contact between the cam surfaces and cam followers is in substance the only mechanical contact between moving parts in the machine 10 save for the seals 214, 216 and 218, and bearings 210. In the present embodiment within the working chamber 18, the wipers 124 of the gate 16 have minimal or indeed no contact with the surface 24 and the lobes 22. Accordingly there is no or only limited wear arising in chamber 18 as a result of contact between components of the machine 10. The wear is by and large limited to that arising from the fluid passing through the machine 10. The provision of rounded corners on the gate 16 and curved surface portions of the surface 24 provides greater control over the tolerance gap between the gate 16 and surface 24 minimising fluid leakage across the gates 16. Further, the provision of the rounded corners/curved surfaces enables easier and uniform application of surface treatments to the surface of stator 14 within the working chamber 18. The provision of the arcuate portions 164 at the radial outer end of gate slots 20 reduces stress in the stator 12 enabling pump 10 to be run at higher pressures for example up to and in excess of 2000psi.

The structure of stator 14 and rotor 12 and in particular the provision of multiple facing surfaces between the working chamber 18 and the space 199 enables the sealing system to incorporate multiple seals as described above thereby enhancing the sealing of the working chamber 18. However as will be explained in greater detail below, the sealing system may incorporate additional or alternate sealing arrangements to further enhance the sealing of chamber 18.

Forming the stator 14 with demountable (i.e. separate) lobes 22 offers numerous benefits and advantages over a stator with integrally formed lobes. For example, the surface 48 can be machined with a uniform outer diameter with the flat lands 54 being milled or otherwise formed subsequently. Thereafter the lobes 22 can be easily mounted onto the lands 54. This is to be contrasted with the difficulty in machining a circumferential stator surface with one or more integral lobes which will require relative displacement between the centre of the stator 14 and a cutting tool while the stator 14 is being machined. Providing the lobes 22 as separate demountable components also

- 23 -

improves reliability and eases maintenance. Further the option becomes available to improve compatibility in the materials from which the stator 14 and the lobes 22 are made and the fluid passing through the machine 10.

- 5 Figure 14 illustrates an example of an alternate sealing arrangement. In this embodiment, the stator 14 is provided with a circumferential lip 220 protruding in an axial direction from face 52 of each flange 50. The lip 220 is disposed a short distance radially inside of the face 53 of flange 50. Disposed between the lip 220 and cam ring 106 is a double chevron seal 222. The seal 222 sits on outer circumferential surface of cam ring 106. An annular Teflon disc or washer 224 also sits on the cam ring 106 and adjacent both the seal 222 and the lip 220. The washer 224 is retained in place by the face plate 144. A dynamic O-ring seal 230 is seated in a groove formed in face plate 144 and seals against an outer circumferential surface of the washer 224.
- 10
- 15 A number of axially extending pressure relief ports 226 are formed in the flange 50 through the radial curved surface 46 into a space 228 between the seal 222 and lip 220. The ports 226 are in fluid communication with the low pressure chamber(s) of the machine. In a motor application this would be the outlet chamber 36. In a pump application the ports would communicate to the inlet chamber 34 adjacent to the inlet port 30. This relieves high pressure from the seal 222 which can slowly leak through the ports 226.
- 20

- Figure 15 illustrates a further embodiment of, or variation to, machine 10 with the aim of maintaining a near zero gap between the legs 136 of the links 128 and the face 168 of the face plate 144. This maintains the sealing area between these components. In this embodiment pins 126 of the gates 16 are retained on corresponding legs 136 of the links 128 by a piston 232 and a nut 234. Piston 232 is seated within a recess 236 formed in the leg 136. A circumferential seal 238 is provided in a groove 240 formed about the outer circumferential surface of piston 232. A further O-ring seal 242 is seated in an inner circumferential groove 244 in piston 232 and surrounds the pin 126. Nut 234 retains the piston 232 on the pin 126. The nut sits in the radial slot 203 of intermediate housing 146 which accommodates the corresponding leg 136.
- 25
- 30

- A shallow recess 250 is formed on a face 252 of piston 232 facing the leg 136 in the axial direction. In this arrangement, fluid pressure is communicated to the recess 250 between the pins 126 and the holes in the legs 136 through which the pins 126 extend. This pressure is the same as the pressure acting in the working chamber 18 and upon the axially inner most surface 254 of leg 136. Also the surface area of the leg on which the pressure from the piston side acts is the same as the surface area on the surface 254 of the same leg 254 on which the pressure from the adjacent working chamber acts. This provides hydraulic balancing across the links 126 to maintain the near zero gap between legs 136 and face 168 of the face plates 144.
- 35
- 40

- 24 -

In an alternative embodiment the back 141 of each leg 136 can be supported on the face of the end caps 146 inside of slots 203. A piston similar to piston 232 is still required but the gate legs 126 would not extend beyond the back 141 of the legs 136. Instead it too would be supported by the back of the end cap on face 203. This would eliminate the need for seal 242.

Figures 16 – 24b depict a second embodiment of the machine. This embodiment is denoted by the reference number 10s. In describing the machine 10s identical reference numbers are used to denote identical features or similar to the machine 10 shown in Figures 1 – 15 but with addition of the suffix “s”.

The machine 10s has the same basic working components as the machine 10 and operates in the same manner. In this regard machine 10s comprises a rotor 12s, stator 14s with a central conduit 26s. A working chamber 18s is defined between the rotor 12s and stator 14s. Fluid flow through the machine 10s is identical to that in the machine 10. The substantive differences between the machines 10 and 10s reside in the structure and/or configuration of the stator 14s, displacement mechanism 125s, cam ring 106s, gates 16s, lobes 22s, rotor 12s and sealing arrangement between the stator 14s and the rotor 12s.

Figures 16 – 19b show in particular the modified configuration of the displacement mechanism 125s, cam rings 106s, and associated components of the rotor 12s. In the machine 10s, the rotor 12s comprises a central or intermediate housing 142s identical to the housing 142; but in place of the individual face plates 144 and end caps 146, the housing 10s comprises integrated end caps 146s on each side of the intermediate housing 142s. Each of the integrated end caps 146s houses a plurality of displacement mechanisms 125s.

In general terms, the integrated end cap 146s may be considered to be a combination of an end cap 146 and the face plate 144. End cap 146s is in the form of an annulus having: a central opening 280 through which opposite sides of the conduit 26s pass; and, opposite radial surfaces 168s and 196s. The surfaces 168s are directed toward the intermediate housing 142s of the rotor 12s while the radial surfaces 196s face away from the intermediate housing 124s. An outer circumferential shoulder 281 (see Figs. 17a and 18b) is formed about an outer radius of the surface 168s, and an inner circumferential shoulder 282 is formed about an inner radius of the surface 168s. In the assembled rotor 12s, the shoulder 281 engages the shoulder 157s in the intermediate housing 142s and the surface 168s abuts the radial face 158s.

The ball bearings 210s are shown seated in the end caps 146s. O-rings 147 (shown in Figures 17a and 19a) are held in annular grooves formed in the opposite faces 52s of the stator 14s. The O-rings 147 bear against and provide a small bias to the bearings 210s. This assists in maintaining a tight fit of the bearings 210s between stator 14s

- 25 -

and the rotating integrated end caps 146s.

O-rings 277 form a seal between the end caps 146s and respective adjacent faces of the intermediate housing 142s. Each O-ring 277 is formed with a plurality of radial
5 hoop extensions 297. The extensions 279 extend about the ends of respective slots 20s in the end caps 146s. The surfaces 168s are provided with shallow grooves (not shown) to seat the O-rings 277.

With particular reference to Figures 18a and 18b a number of substantially rectangular
10 and evenly spaced apart link recesses 202s are formed in the radial face 196s of integrated end cap 146s. Each link recess 202s terminates in a planar back wall 286. Respective slots 174s open onto the wall 286 of each link recess 202s, and onto the radial surface 168s. The slots 174s correspond with the slots 174 in the machine 10. Four holes 288a, 288b, 288c and 288d (hereinafter referred to in general as "holes
15 288") are formed in the integrated end cap 146s in each link recess 202s. The holes 288a and 288b extend in a generally radial direction from an outer circumferential surface 290 of the integrated end plate 146s opening into a radially outer face of the link recess 202s. The two holes 288c and 288d also extend in a generally radial
20 direction and extend between a radially inner face of the link recess 202s and an inner circumferential surface 292 of the integrated end plate 146s. The surface 292 forms a seat for the ball bearing 210s. Each link recess 202s is located between or inboard of the outer and inner circumferential surface 290, 292.

An annular groove 293 is formed radially outward of the surface 292 on the same side
25 of the integrated end cap 146s. The holes 288a and 288c have a common axis as do holes 288b and 288d. The axes of these respective pairs of holes are parallel to each other. A number of axially extending through holes 294 are provided in the integrated end plate 146s for receiving bolts 296 (see Figure 17a) used to attach the integrated end caps 146s onto opposite sides of the intermediate housing 142s.

30 The links 128s of the displacement mechanisms 125s comprise substantially rectangular blocks 298 which are functionally similar to the legs 136 of the machine 10. Rollers 138s and 140s are rotatably mounted on each block 298 on respective axles 299. The rollers 138s and 140s are on the same side of the block 298 and are radially
35 aligned with each other. A pair of parallel spaced apart holes 300 is formed in each block 298 and extends in a generally radial direction. The holes 300 seat respective cylindrical bearings 302. Each block 298 is mounted in a respective link recess 202s by a pair of parallel guides or rails 304. One of the rails 304 passes through hole 288a, an aligned bearing 302 and hole 288c, while the other passes through the hole 288b,
40 an aligned bearing 302 of the same block 298 and hole 288d. The blocks 298 are dimensioned to be smaller in the radial direction than the link recesses 202s to enable the links 128s to reciprocate in a generally radial direction along the rails 304. The rails 304 are held in place by grub screws 381 which screw into holes 383 formed the radial

- 26 -

surface 196s of integrated end cap 146s.

With particular reference to Figures 18a and 19b, the rollers 138s and 140s are formed with integral axles 299. The axles 299 are received in each of two aligned bearings 5 301 which in turn are seated in respective holes 303 in the block 298. A screw 305 and washer 307 engage each axle 299 to retain them within bearings 303. A plate 309 is attached by screws 311 on a front face of the blocks 294 to hold the bearings 301 in the blocks 298.

10 Still referring to Figures 18a and 19b a blind hole 306 is formed in an axial direction into a back face 308 of block 298. The hole 306 is configured to receive the pin 126s at one end of a respective wiper 124s. The back face 308 is also formed with a shallow wide recess 310. Penetrating further into the back face 308 from the recess 310 are 15 two endless grooves 312 and 314 each in the general configuration of an ellipse. The grooves 312 and 314 seat respective O-rings 315a, 315b. A relatively thin seal plate 316 sits in the recess 310 against the O-rings 315a, 315b and is provided with a hole 317 through which the pin 126s extends. The hole 317 is in alignment with the hole 306.

20 A further seal plate 318 is seated in a shallow recess 320 formed in the back wall 286 of link recess 202s. A pair of endless grooves 322 and 324 penetrates from the recess 320 further into the back wall 286. O-rings 325a and 325b are seated in grooves 322 and 324, respectively. The seal plate 318 is formed with a longitudinal slot 326 which is in registration with (i.e. coincide in location and configuration with) a respective pin 25 slot 174s. As the link 128s reciprocates, the seal plate 316 moves with the block 298 while the seal plate 318 is stationary relative to the integrated end cap 146s. Facing surfaces of the seal plates 316 and 318 are highly polished to the extent of forming a substantial fluid seal there between. This provides a mechanical fluid seal preventing working fluid from leaking from the working chamber through the recesses 202s.

30 Reciprocation of the links 128s and thus the displacement mechanism 125s is caused by the rotation of the rotor 12s and the cooperation of the rollers 138s and 140s with the respective cam rings 106s. Each cam ring 106s replaces the cam surfaces 102 and 104 on each side of the stator 14 in the machine 10. Thus, instead of requiring 35 one cam ring 106 and three cam shoes 118 on each side of the stator 14 as per machine 10, in machine 10s, a single cam ring 106s is used to provide both cam surfaces 102s and 104s (see Figs. 16 and 19b). The cam ring 106s is in the form of a planar annular disc 107 with an axially extending continuous cam rail 109.

40 In place of the seals 214, 216 and 218 shown in Figure 1 and the alternate sealing system shown in Figure 14; the embodiment of Figures 16-24b has a sealing system which comprises mechanical fluid seals. Respective mechanical seals are provided between each end cap 146s and the respective adjacent face 52s of the stator 14s.

- 27 -

With particular reference to Figures 16, 17b, 18a, 19a and 19c each mechanical seal comprises a stator sealing ring R1 and an end cap sealing ring R2.

5 The ring R1 is in the form of a metal ring body 327 which is held by bolts 329 in a circumferential recess 52r formed on face 52s (Figures 17b and 19c). An annulus 331 made from a wear resistant material such as tungsten carbide having a polished axial face 333 is held in the ring body 327. The annulus 331 is biased toward the sealing ring R2 by a spring 313.

10 The ring R2 is held in the groove 293 in the integrated end cap 146s and has a polished face 335 that is arranged to contact the face 333. The polished face 333 may be made from or at least coated with the same wear resistant material as that used for the annulus 331. The two polished faces 333 and 335 are biased into contact by the spring 313 and form a seal against each other preventing the passage of fluid there
15 between.

20 Figures 20a – 22b depict the modified gate 16s of the machine 10s. Each gate 16s performs the same function as the gate 16 in the machine 10. In particular each gate 16s is provided with a central wiper or blade 124s. The pins 126s are formed separately from the wiper 124s and inserted into holes on opposite sides of the wiper 124s. Opposite ends of the pins 126s are seated in respective links 128s. Each wiper 124s is provided with a series of radially extending channels 135s on one side surface 330. The channels 135s perform a similar function to the channels 135 in the wipers 124.
25

A recess 332 is formed in the wiper 124s which opens onto axial planar surface 132s and adjacent opposed curved surfaces 130s of the wiper 124s. The recess 332 seats a gate seal system 334. The gate seal system 334 comprises in combination one or more flexible planar sealing bands 336 and a biasing element 337 which may be in the
30 form of an O-ring or metal spring. The gate seal system 334 forms a dynamic seal against the circumferential surface 24s.

35 The or each band 336 comprises a straight length 338 and respective integrally formed curved portions 340 at each end. Each curved portion 340 terminates in an inwardly directed peg 342. The overall radial outer most shape and configuration of the sealing band 336 is substantially the same as the shape and configuration of the surfaces 130s and 132s of the wiper 124s.

40 The flexibility of the sealing bands may be provided by way of the material used to make the bands. That is, by using a flexible material the bands will have inherent flexibility. Alternately or additionally flexibility can be provided by forming a plurality of transverse slots 344 in the band 336. The slots 344 formed in the curved portions 340 facilitate flexing of the curved portions in a plane containing a corresponding sealing

- 28 -

band. The slots 344 on mutually adjacent sealing band 336 are laterally offset from each other. As a consequence when two or more bands 336 are placed adjacent each other there is no direct fluid flow path across the gate seal system 334 through the slots 344.

5

Two or more of the sealing bands 336 are retained in the recesses 332 by engagement of the pegs 342 in complementary rebates formed inside of the recess 332. The bias mechanism 337 is likewise seated in a complementary groove or recess formed within the recess 332 and positioned to apply a bias on the sealing bands 336 so that they extend beyond the surfaces 130s and 132s of the wiper 124s. Further, the sealing bands 336 are retained in the wiper 124s in a manner to allow axial motion as well as radial motion. In one example, the sealing bands 336 may be made from a metal or alloy such as bronze. The ability of the sealing bands 336 to move axially and radially enables them to maintain contact with surfaces of the stator 14s while allowing for a small degree of relative axial motion between the rotor 12s and the stator 14s arising from engineering tolerance in the manufacture of the machine 10s. Put another way the sealing system 332 enables the manufacture of the machine 10s with less demanding tolerance than machine 10.

10
15
20
25
Figures 22a and 22b illustrate the gate 16s in an inactive position and active position respectively. From these Figures it will also be apparent that the wiper 124s further differs from the wiper 124 in terms of its cross-sectional shape. Specifically, the gate 124s tapers so as to reduce in thickness in a direction from its pins 126s to the surface 132s. These Figures also illustrate a half dovetail slot 350 in slot 20s for seating a sealing strip 352. The sealing strip 352 has a sealing face 353 flush with wall 162s of the slot 20s.

30
In the inactive position the gate 16s is radially aligned with a lobe 22 which in turn is in contact with the inner circumferential surface of the rotor 12s on opposite sides of the slot 20s. When in this configuration the gate 16s is in an uplifted position by virtue of the action of the links 128s and cooperating cam ring 106s. As shown in Figure 22a, the sealing bands 336 are lifted from the lobes 22.

35
40
Figure 22b illustrates the gate 16s in an active position where it seals against the circumferential surface 24 of stator 14s. In this position the wiper 124s is moved radially toward the surface 24 by action of the links 128s and cam rings 106s. The gate 16s is brought to a position where the outer peripheral edges of the sealing bands 336 contact the surface 24s. While the planar surface 132s of the wiper 124s is marginally spaced from the surface 24s, the sealing bands 336 are positioned to contact with the surface 24s by action of the bias mechanism 337. Moreover, the sealing system 334 is in effect a floating mechanical sealing system maintaining contact with the surface 24s while allowing axial displacement between the rotor 14s and stator 12s arising from engineering tolerances in the manufacture of the machine 10.

- 29 -

When in the active position the wiper 124s also contacts and seals against the sealing strip 352. This prevents fluid from the high pressure side (in this instance on the right hand side of the gate 16s in Figure 22b) from leaking into the low pressure side. The seal is affected by the contact between the sealing strip 352 and a surface of the wiper 124s together with a tilting of the gate 16s by action of the high pressure fluid acting on the portion of the wiper 124s within the working chamber. This applies a torque to the gate 16s in a clockwise direction about the pins 126s.

As a gate 16s transitions between the active and inactive positions (i.e. as the gate 16s moves further into slot 20s) the channels 135s allow fluid above the gate 16s in the slot 20s to flow past the wiper 124s into the working chamber. This assists in minimising the risk of hydraulically locking the gates 16s.

Figures 23a – 23c depict an alternate form of lobe 22s which is incorporated in the machine 10s. The substantive difference between the lobe 22s and the lobe 22 resides in the location and configuration of the ramps 86 and the configuration of central portion 84s. The ramps 86s and central portion 84s are made as separate components which are interfitted when assembled on the machine 10s. The central portion 84s has a generally similar configuration to the portion 84 with the main differences being the provision of slots 380 to receive the legs 86s, and the squaring of the upper edges 382. In contrast in the machine 10, the lobes 22 are formed with sloping or cambered longitudinal edges. The ramps 86s are located nearer the longitudinal ends of the central portion 84s so that when the lobe 22s is fitted onto the stator 14s (as shown in Figure 24a) the ramps 86s do not bridge across the ports 30 and 32. Rather the ramps 86s extend across the outer circumferential surface 24s at locations beyond the axial ends of the ports 30 and 32. Additionally, as shown most clearly in Figure 24b, recessed slots 384 are formed in the surface 24s of stator 14s for receiving the respective ramps 86s. Also, an endless groove 386 is formed in a land 54s for receiving an O-ring (not shown) to act as a seal between the lobe 22s and the land 84s.

Figures 25a-26b illustrate a further possible configuration of gates 16' that may be incorporated in alternate embodiments of the rotary fluid machine. The gate 16' differs in several respects to the gate 16s shown in Figures 20a-21b. Gate 16' comprises a wiper 124' pin provided with respective holes 127' formed at opposite ends to receive respective pins 126'. Wiper 124' is formed with: thickened ribs 400 at opposite ends and extending in a radial direction; and, a central thickened rib 402. The side surface 330' between the ribs 400 and 402 is tapered and provided with channels 135' as in the wiper 124s.

The gate 16' is also formed with a recess 332' for seating a gate seal system 334'. The gate seal system 334' comprises: one or more sealing bands 336'; and, biasing

- 30 -

elements 337' which in this embodiment are in the form of lengths of resilient material such as but not limited to rubber. The biasing elements 337' are seated within grooves (not shown) formed within the wiper 124'.

5 Each sealing band 336' is formed at opposite ends with integral pegs 342' similar to the
pegs 342 of the gates 16s. However in the gates 16', each peg 342' is formed with a
through hole 343. Additionally, the sealing band 336' is formed with a central tab 406
which is also formed with a through hole 408. Each sealing band 336' is held within the
10 recess 332' by pins 410 which pass through holes 412 formed in the ribs 400 and 402
as well as through the holes 343 and 406.

The sealing bands 336' are formed with slots 334' but only in the vicinity of the end
curved portions 340'. This provides a degree of flexibility enabling the curved portions
340' to flex inwardly or outwardly in the plane containing the sealing band 336'.

15 However the ability for the sealing band 336' to move radially and axially is provided by
the pins 410 in holes 343 and 406. Specifically, the holes 343 and 406 are formed of a
greater diameter than the pins 410. This provides a degree of clearance between the
pins 410 and the circumferential surfaces of the holes 343 and 406.

20 Figures 26a and 26b depict the operation of the gate 16' when in the inactive and
active positions respectively, which is the same as for the gates 16s. However when
using the gates 16', the rotor 12' is provided with two sealing strips 352'a and 352'b one
in each of the walls 162' of each slot 20'. The sealing strips 352'a and 352'b are
diametrically opposed from each other and engage in respective dovetail slots 350'.
25 The sealing strip 352'a has a sealing face 353'a which is flush with the wall 162' in
which it is seated and contacts the back face of wiper 124'. The sealing strip 352'b has
a sealing face 353'b which is flush with the wall 162' in which it is seated and contacts
the surface of ribs 400 and 402. However fluid is able to flow through the slots 135' on
the tapered side surface 330' between the ribs 400 and 402.

30
Now that an embodiment of the invention has been described in detail it will be
apparent to those skilled in the relevant arts that numerous modifications and variations
may be made without departing from the basic inventive concepts. In particular, it is
envisaged that the sealing system described herein above may be varied to provide
35 alternate sealing mechanisms and/or pressure balancing which assists in sealing and
maintaining of seals.

40 It will be further understood by those skilled in the art that other modifications and
variations may be made to the machine 10. For example in the illustrated embodiment,
the stator 14 is illustrated as being provided with one hub 42. However a number of
co-axial hubs 42 may be formed on the stator 14. A separate rotor may then be
mounted on that hub to in effect provide two machines on a single stator 14. The fluid
flowing out of a first machine is used as the fluid source for the next machine. Also two

- 31 -

types of gate seal system 334s and 334' are described each incorporating different types of sealing bands 336. The illustrated sealing band each has a number of slots 344 although arranged differently in terms of location. It is envisaged that in alternate embodiments the sealing bands could be made without any slots 344 by appropriate selection of the material from which the sealing band are made. In yet a further variation, slots 344 in the straight length 338 of sealing bands may be orientated parallel to the straight length 338, rather than transverse as currently depicted in Figure 21b. Additionally, the different variations and/or modifications described of various features or components that are common to the different embodiments can be interchangeably used and not limited to any specific embodiment. For example any of gates the 16, 16s and 16' may be incorporated in machines 10 and 10s; similarly either of lobes 22 or 22s may be incorporated in machines 10 and 10s. All such modifications and variations together with others that will be obvious to persons or ordinary skill in the art are deemed to be within the scope of the present invention the nature of which is to be determined from the above description and the appended claims.

- 32 -

Claims:

1. A rotary fluid machine comprising:
first and second bodies, the bodies being rotatable relative to each other and
5 arranged one inside the other to define at least one working chamber there between;
at least one gate supported by the first body, each gate having: a planar axial
surface and respective rounded corners at each end of the axial surface;
the second body comprising a circumferential surface forming a surface of the
working chamber, the circumferential surface having an intermediate surface extending
10 in an axial direction and contiguous curved surfaces on each side of the intermediate
surface and extending in a radial direction to form with the intermediate surface a U
shaped channel, wherein when the planar axial surface is adjacent the intermediate
surface, the rounded corners and the curved surfaces lie closely adjacent to and
substantially parallel with each other.
15
2. The rotary fluid machine according to claim 1 wherein each gate is arranged to
cyclically extend from and retract into the first body in a radial direction as one body
rotates relative to the other body.
- 20 3. The rotary fluid machine according to claim 1 or 2 wherein each of the curved
surfaces and the rounded corners smoothly curve through 90 degrees.
4. The rotary fluid machine according to any one of claims 1 - 3 wherein the
rounded corners of the gate are convexly curved and the curved surfaces of the
25 second body are concavely curved.
5. The rotary fluid machine according to claim 4 wherein the second body
comprises a stator of the machine and is rotationally fixed and the first body comprises
a rotor of the machine and rotates relative to the stator.
30
6. The rotary fluid machine according to claim 5 wherein the second body is
disposed inside the first body.
7. The rotary fluid machine according to any one of claims 1 – 6 wherein the or
35 each gate comprises a wiper and a gate seal system supported by the wiper, the gate
seal system arranged to form a dynamic seal against the circumferential surface of the
second body.
8. The rotary fluid machine according to claim 7 wherein the wiper is provided with
40 the planar axial surface and the respective rounded corners and the gate seal system
comprises one or more sealing bands supported in the wiper and extendable from the
planar axial surface and respective rounded corners.

- 33 -

9. The rotary fluid machine according to claim 8 wherein the or each sealing band is resilient biased to extend from the planar axial surface and respective rounded corners.
- 5 10. The rotary fluid machine according to claim 8 or 9 wherein the or each sealing band is axially and radially movable relative to the wiper.
11. The rotary fluid machine according to any one of claims 8 – 10 wherein each sealing band comprises a flexible strip of material.
- 10 12. The rotary fluid machine according to any one of claims 8 – 11 wherein each sealing band comprise a straight length and curved portions at each end of the straight length, and a plurality of slots formed in the curved portions to facilitate flexing of the curved portions in a plane containing a corresponding sealing band.
- 15 13. The rotary fluid machine according to any one of claims 8 – 12 wherein each sealing band comprise a plurality of slots formed in the straight length.
14. The rotary fluid machine according to any one of claims 8 – 11 wherein the gate seal system comprise at least two sealing bands juxtaposed face to face, each sealing band being provided with a plurality of slots to facilitate flexing of the sealing bands, and wherein the sealing bands and slots are arranged so that there is no direct fluid flow path between opposite sides of the gate seal system through the slots.
- 20 15. The rotary fluid machine according to any one of claims 1 – 14 wherein each gate is provided with one or more radially extending channels to enable fluid flow between radially opposite ends of the gate.
- 25 16. The rotary fluid machine according to claim 15 wherein the radially extending channels extend through the gate and open onto the radially opposite ends of the gate.
- 30 17. The rotary fluid machine according to claim 15 wherein the radially extending channels are formed on one side surface of the gate.
- 35 18. The rotary fluid machine according to any one of claims 1 - 17 comprising a gate displacement system operable to displace the gate in a radial direction upon rotation of the first body relative to the second body.
- 40 19. The rotary fluid machine according to claim 18 wherein the gate displacement system comprises for each gate, two gate links coupled one on each side of the gate, and cam surfaces arranged to guide the gate links to move in the radial direction as the first and second bodies rotate relative to each other, the gate links and the cam surfaces being disposed outside of the working chamber.

- 34 -

20. The rotary fluid machine according to claim 19 wherein each gate link comprises two cam followers arranged to engage respective cam surfaces.
- 5 21. The rotary fluid machine according to claim 20 wherein each gate link is slidably retained within the first body and coupled by a pin to a corresponding gate.
22. The rotary fluid machine according to claim 21 wherein the first body comprises a radially extending pin slot for each pin, each pin extending axially through a
10 corresponding pin slot to couple with a corresponding link, and a pin slot sealing arrangement operable to form a substantially seal about the pin slot.
23. The rotary fluid machine according to any one of claims 20 - 22 wherein each
15 gate link comprises a leg coupled at one end to corresponding pin and wherein the cam followers are co-axially coupled near an opposite end of the leg.
24. The rotary fluid machine according to claim 23 wherein the first body is provided
with a link recess for each leg, each link recess being closed at one end and opened at
an opposite end, wherein each leg is slidably retained in a respective link recess.
20
25. The rotary fluid machine according to claim 23 or 24 wherein the cam surfaces
comprise, on each side of the working chamber, first and second cam surfaces fixed to
the second body and axially offset relative to each other.
- 25 26. The rotary fluid machine according to any one of claims 20 - 22 wherein the first
body is provided with a link recess for each link, each link recess being formed inboard
of a radially inner most and a radially outer most edge of the first body, wherein each
link is slidably retained in a respective link recess.
- 30 27. The rotary fluid machine according to claim 26 wherein two cam followers are
rotatable coupled on respective axles on a same side of the link.
28. The rotary fluid machine according to claim 26 or 27 wherein the pin slot sealing
arrangement comprises first and second seal plates arranged face to face wherein a
35 the first seal plate is coupled to and moves with the link, the first seal plate further
provided with a hole through which the pin extends; and a the second seal plate is
coupled to and fixed relative to the first body, the second seal plate being provided with
a slot being in registration with a respective pin slot formed in the first body.
- 40 29. The rotary fluid machine according to claim 26 - 28 wherein the cam surfaces
comprise, on each side of the working chamber, opposite sides of a continuous cam
rail.

- 35 -

30. The rotary fluid machine according to any one of claims 19 - 29 wherein the wherein the first body comprises an intermediate housing provided with a plurality of blind gate slots within which respective gates reciprocate.
- 5 31. The rotary fluid machine according to claim 30 comprising first and second end caps coupled at axially opposite ends of the intermediate housing, wherein the gate links are disposed in the end caps.
- 10 32. The rotary fluid machine according to claim 31 comprising a mechanical fluid seal on each side of the working chamber to provide a substantial fluid seal between the working chamber and the end caps.
- 15 33. The rotary fluid machine according to claim 32 wherein the mechanical fluid seal comprises on each side of the working chamber a first ring fixed to first body and a second ring fixed to the second body, the rings being provided with polished surfaces biased into contact with each other.
- 20 34. The rotary fluid machine according to any one of claims 1 - 33 wherein the second body comprises one or more pairs of ports, each pair of ports comprising a fluid inlet port and a fluid outlet port and, one or more lobes demountable coupled to the second body and configured to project from the circumferential surface of the second body, each lobe: located between the inlet and outlet ports in a pair of ports; and, comprising a central portion and at least one ramp extending from each side of the central portion to the circumferential surface, the at least one ramp having a ramp surface that provides a transition between the circumferential surface to an upper surface of the central portion.
- 25 35. The rotary fluid machine according to claim 33 or 34 wherein the ports are provided with chamfered surfaces leading to the circumferential surface and the ramps seat on the chamfered surfaces.
- 30 36. The rotary fluid machine according to any one of claims 33 - 35 wherein each lobe comprises two ramps extending from each side of the central portion.
- 35 37. The rotary fluid machine according to any one of claims 33 - 36 wherein the central portion and the ramps are formed as separate parts and interfitted with each other when a corresponding lode is coupled to the body.
- 40 38. The rotary fluid machine according to any one of claims 33 - 35 wherein the central portion extends in an axial direction across the circumferential surface.
39. The rotary fluid machine according to any one of claims 33 - 38 wherein the lobes are disposed in an axial direction between the contiguous curved surfaces.

- 36 -

- 5 40. The rotary fluid machine according to any one of claims 33 - 39 comprising a coupling mechanism for demountably coupling each of the lobes to the body, the coupling mechanism comprising a locking member that engages a corresponding lobe at a location radially inside of the circumferential surface.
- 10 41. The rotary fluid machine according claim 40 wherein each lobe comprises one or more lugs extending in a radial inward direction and configured for engagement with the locking member.
- 15 42. The rotary fluid machine according to any one of claims 30 - 41 wherein each gate slot comprises two spaced apart and parallel flat surfaces which face each other and extend at one end to an inner circumferential surface of the intermediate housing, and a contiguous arcuate portion extending between respective distant ends of the flat surfaces forming a blind end of the gate slot.
- 20 43. The rotary fluid machine according to claim 42 wherein the contiguous arcuate surface has a diameter greater than a transverse distance between the flat surfaces.
- 25 44. The rotary fluid machine according to claim 42 or 43 wherein the flat surfaces are separated by a transverse distance W and the acuate portion has a diameter D and $W \leq D \leq 5W$.
- 30 45. A body for a fluid rotary machine, the body comprising:
one or more pairs of ports, each pair of ports comprising a fluid inlet port and a fluid outlet port; and
one or more lobes demountable coupled to the body and configured to project from a circumferential surface of the body, each lobe: being located between the inlet and outlet ports in a pair of ports; and, comprising a central portion and at least one ramp extending from each side of the central portion to the circumferential surface, the at least one ramp having a ramp surface that provides a transition between the circumferential surface to an upper surface of the central portion.
- 35 46. The body according to claim 45 wherein portions of the circumferential surface of the body on either side of a lobe have a constant radius.
47. The body according to claim 46 wherein a portion of the circumferential surface underlying the central portion is flat.
- 40 48. The body according to any one of claims 45 - 47 wherein the ports are provided with chamfered surfaces leading to the circumferential surface and the at one ramps seat on the chamfered surfaces.

- 37 -

49. The body according to any one of claims 45 - 48 wherein each lobe comprises two ramps extending from one side of the central portion and two ramps extending from an opposite side of the central portion.
- 5 50. The body according to any one of claims 45 - 49 wherein respective ramps bridge across the inlet and outlet ports in a pair of ports.
51. The body according to any one of claims 45 - 50 wherein the central portion and the ramps are formed as separate parts and interfitted with each other when a
10 corresponding lobe is coupled to the body.
52. The body according to any one of claims 45 - 51 wherein the central portion extends in an axial direction across the circumferential surface.
- 15 53. The body according to any one of claims 45 - 52 wherein the upper surface of central portion is a continuous surface.
54. The body according any one of claims 45 - 51 wherein the circumferential surface of the body comprises an intermediate surface extending in an axial direction
20 and contiguous curved surfaces, one on each side of the intermediate surface and extending in a radial direction, and wherein the lobes are disposed in an axial direction between the contiguous curved surfaces.
55. The body according to claim 54 wherein the contiguous curved surfaces are
25 provided on flanges extending radially of and about the body.
56. The body according to claim 55 wherein the continuous surface on the central portion has a curvature the same as that of an outer circumferential surface of the
30 flanges.
57. The body according to any one of claims 45 - 56 comprising a coupling mechanism for demountably coupling each of the lobes to the body, the coupling mechanism comprising a locking member that engages a corresponding lobe at a location radially inside of the circumferential surface.
35
58. The body according to claim 57 wherein each lobe comprises one or more lugs extending in a radial inward direction and configured for engagement with the locking member.
- 40 59. The body according to claim 58 wherein each lug comprises a hole through which the locking member passes to engage the lobe.
60. A rotary fluid machine comprising:

- 38 -

a first body;

a second body comprising the body accordance with any one of claims 45 - 59, the first and second bodies being rotatable relative to each other and arranged one inside the other to define at least one working chamber there between; and

5 at least one gate, the or each gate movable within respective gate slots formed in the first body, each gate being movable to wipe across the circumferential surface of the second body and the lobes when the bodies rotate relative to each other.

61. The rotary machine according to claim 60 wherein the second body is a stator
10 of the machine and lies inside of the first body.

62. The rotary machine according to claim 60 or 61 wherein each gate comprises a
planar axial surface and respective rounded corners at each end of the planar axial
surface and wherein when the planar axial surface is adjacent the intermediate surface,
15 the rounded corners and the curved surfaces lie closely adjacent to and substantially
parallel with each other.

63. A body for a fluid rotary machine, the body forming a rotor or a stator of the
machine and comprising:
20 one or more radially extending blind gate slots that open onto a circumferential
surface of the body, each gate slot having two spaced apart and parallel flat surfaces
which face each other and extend at one end to the circumferential surface and a
contiguous arcuate portion extending between respective distant ends of the flat
surfaces forming a blind end of the gate slot.

25 64. The body according to claim 63 wherein the contiguous arcuate surface has a
diameter greater than a transverse distance between the flat surfaces.

65. The body according to claim 63 or 64 wherein the flat surfaces are separated by
30 a transverse distance W and the arcuate portion has a diameter D and $W \leq D \leq 5W$.

66. The body according to any one of claims 63 - 65 comprising: an intermediate
housing provided with the blind gate slots; and, two face plates one disposed on either
side of the intermediate housing, each face plate provided with a plurality of pin slots
35 formed inboard of radial inner and radial outer edges of the face plates and passing
through a thickness of the face plates, the pin slots in the face plates positioned to
register with the blind slots in the intermediate housing.

67. The body according to claim 66 wherein each face plate is provided with a
40 plurality of seals, each seal circumscribing a corresponding pin slot in the face plate on
a side distant the intermediate housing.

- 39 -

68. The body according to claim 66 or 67 comprising two end caps, one adjacent each face plate, and wherein an outer circumferential surface of the face plates is located radially inward of respective outer circumferential surfaces of the intermediate housing and the end caps.

5

69. The body according to claim 68 wherein each end cap is provided with a plurality of radially extending link recesses on a side adjacent the face plates, the radially extending link recesses being closed at a radial outer end and open at a radial inner end.

10

70. The body according to claim 66 comprising an intermediate housing provided with the blind gate slots and first and second end caps coupled at axially opposite ends to the intermediate housing, each end cap being provided a plurality of link recesses formed inboard of a radially inner most and a radially outer most edge of a corresponding end cap.

15

71. The body according to claim 70 wherein each end cap is provided with a plurality of pin slots formed inboard of radial inner and radial outer edges of a corresponding end cap, the pin slots in the end caps positioned to register with the blind slots in the intermediate housing and opening onto respective link recesses.

20

72. The body according to claim 71 comprising a respective sealing arrangement associate with each link recess and respective pin slot, each sealing arrangement comprising first and second seal plates arranged face to face wherein the first seal plate arranged to move within a corresponding link recess, the first seal plate further provided with a through hole configured to receive a pin, and the second seal plate is fixed within the corresponding link recess, the second seal plate being provided with a slot in registration with a respective pin slot of the corresponding link recess.

25

73. A rotary fluid machine comprising:

30

first and second bodies, the first body being provided with one or more radial gate slots, the bodies being rotatable relative to each other and arranged one inside the other to define there between: at least one working chamber;

at least one gate movable in a radial direction within a respective radial gate

35

slot; and

a gate displacement mechanism operable to displace the or each gate in a radial direction within a corresponding gate slot upon rotation of the first body relative to the second body;

wherein the gate displacement mechanism comprises, for each gate: two gate links coupled one on each side of the gate; and, cam surfaces arranged to guide the gate links to move in the radial direction as the first and second bodies rotate relative to each other, the gate links and the cam surfaces being disposed outside of the working chamber.

40

- 40 -

74. The rotary fluid machine according to claim 73 wherein each gate link comprises two cam followers arranged to engage respective cam surfaces.
- 5 75. The rotary fluid machine according to claim 74 wherein each gate link is slidably retained within the first body and coupled by a pin to a corresponding gate.
76. The rotary fluid machine according to claim 75 wherein the first body comprises a radially extending pin slot for each pin, each pin extending axially through a
10 corresponding pin slot to couple with a corresponding link, and a sealing arrangement operable to form a substantially seal about the pin slot.
77. The rotary fluid machine according to any one of claims 73 - 75 wherein each
15 gate link comprises a leg coupled at one end to corresponding pin and wherein the cam followers are co-axially coupled near an opposite end of the leg.
78. The rotary fluid machine according to claim 77 wherein the first body is provided
with a link recess for each leg, each link recess being closed at one end and opened at
20 an opposite end, wherein each leg is slidably retained in a respective link recess.
79. The rotary fluid machine according to claim 77 or 78 wherein the cam surfaces
comprise, on each side of the working chamber, first and second cam surfaces fixed to
the second body and axially offset relative to each other.
- 25 80. The rotary fluid machine according to any one of claims 73 - 75 wherein the first
body is provided with a link recess for each link, each link recess being formed inboard
of a radially inner most and a radially outer most edge of the first body, wherein each
link is slidably retained in a respective link recess.
- 30 81. The rotary fluid machine according to claim 80 wherein two cam followers are
rotatable coupled on respective axles on a same side of the link.
82. The rotary fluid machine according to claim 80 or 81 wherein the sealing
arrangement comprises first and second seal plates arranged face to face wherein a
35 the first seal plate is coupled to and moves with the link, the first seal plate further
provided with a hole through which the pin extends; and a the second seal plate is
coupled to and fixed relative to the first body, the second seal plate being provided with
a slot being in registration with a respective pin slot formed in the first body.
- 40 83. The rotary fluid machine according to claim 80 - 82 wherein the cam surfaces
comprise, on each side of the working chamber, opposite sides of a continuous cam
rail.

- 41 -

84. The rotary fluid machine according to any one of claims 73 - 83 wherein the wherein the first body comprises an intermediate housing provided with the one or more gate slots.
- 5 85. The rotary fluid machine according to claim 84 comprising first and second end caps coupled at axially opposite ends of the intermediate housing, wherein the gate links are disposed in the end caps.
- 10 86. The rotary fluid machine according to claim 85 comprising a mechanical fluid seal on each side of the working chamber to provide a substantial fluid seal between the working chamber and the end caps.
- 15 87. The rotary fluid machine according to claim 86 wherein the mechanical fluid seal comprises on each side of the working chamber a first ring fixed to first body and a second ring fixed to the second body, the ring provided with polished surfaces biased into contact with each other.
- 20 88. A gate for a rotary fluid machine having first and second bodies, the first body being provided with one or more radial gate slots, the bodies being rotatable relative to each other and arranged one inside the other to define a working chamber there between, the working chamber having a circumferential surface, the gate comprising:
a wiper and a sealing system supported by the wiper and arranged to form a dynamic seal against the circumferential surface of the second body.
- 25 89. The gate according to claim 88 wherein the wiper is provided with a planar axial surface and respective rounded corners at opposite ends of the planar axial surface and the sealing system comprises one or more sealing bands supported in the wiper and extendable from the planar axial surface and respective rounded corners.
- 30 90. The gate according to claim 89 wherein the or each sealing band is resilient biased to extend from the planar axial surface and respective rounded corners.
- 35 91. The gate according to claim 89 or 90 wherein the or each sealing band is axially and radially movable relative to the wiper.
92. The gate according to any one of claims 89 – 91 wherein each sealing band comprises a flexible strip of material.
- 40 93. The gate according to any one of claims 89 – 92 wherein each sealing band comprise a straight length and curved portions at each end of the straight length, and a plurality of slots formed in the curved portions to facilitate flexing of the curved portions in a plane containing a corresponding sealing band.

- 42 -

94. The gate according to any one of claims 89 – 93 wherein each sealing band comprises a plurality of slots formed in the straight length.

5 95. The gate according to any one of claims 89 – 94 wherein the sealing system comprise at least two sealing bands juxtaposed face to face, each sealing band being provided with a plurality of slots to facilitate flexing of the sealing bands, and wherein the sealing bands and slots are arranged so that there is no direct fluid flow path between opposite sides of the sealing system through the slots.

10 96. The gate according to any one of claims 88 – 95 wherein each gate is provided with one or more radially extending channels to enable fluid flow between radially opposite ends of the gate.

15 97. The gate according to claim 96 wherein the radially extending channels extend through the gate and open onto the radially opposite ends of the gate.

98. The gate according to claim 96 wherein the radially extending channels are formed on one side surface of the gate.

20

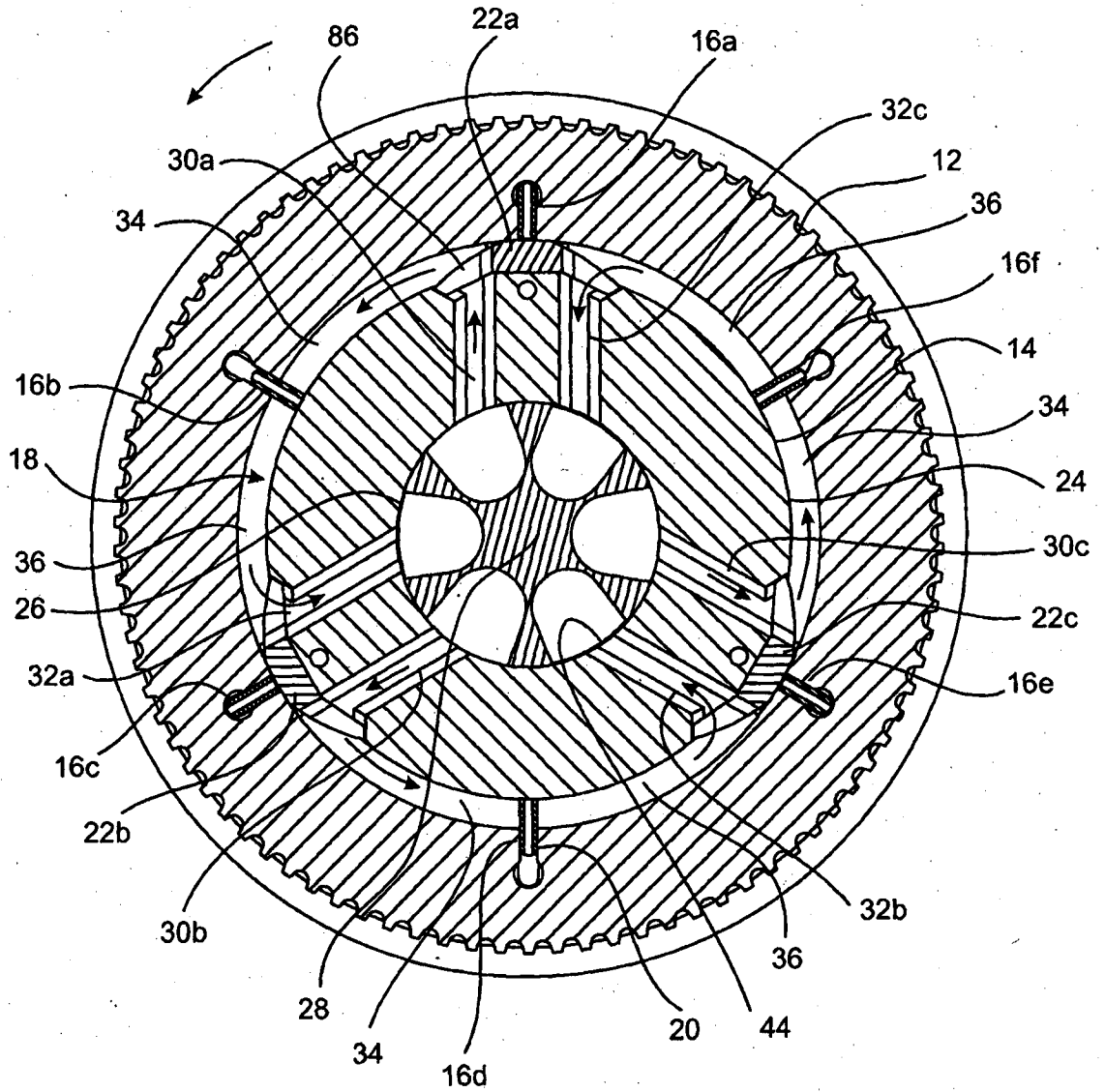

Fig 2

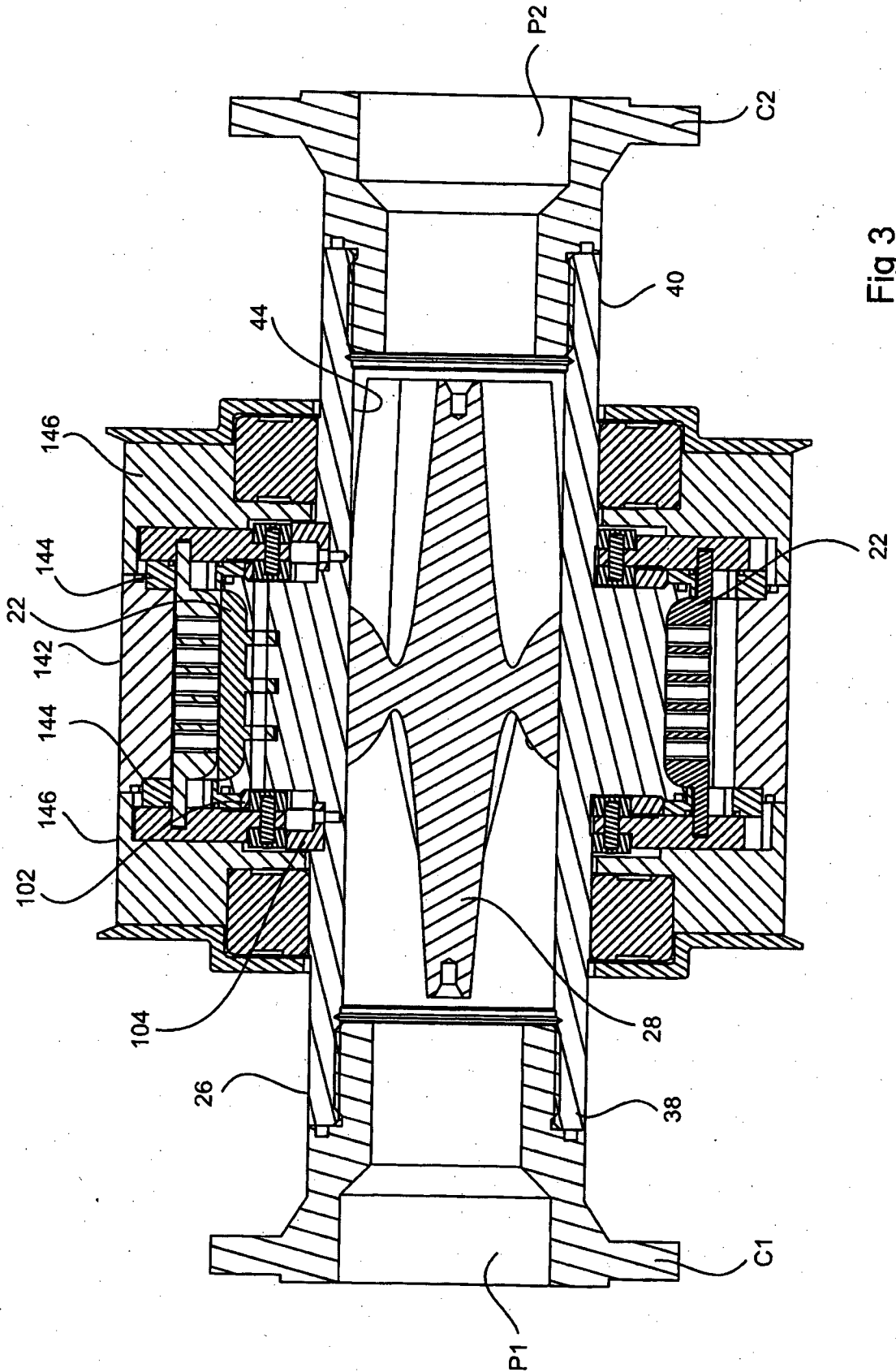

Fig 3

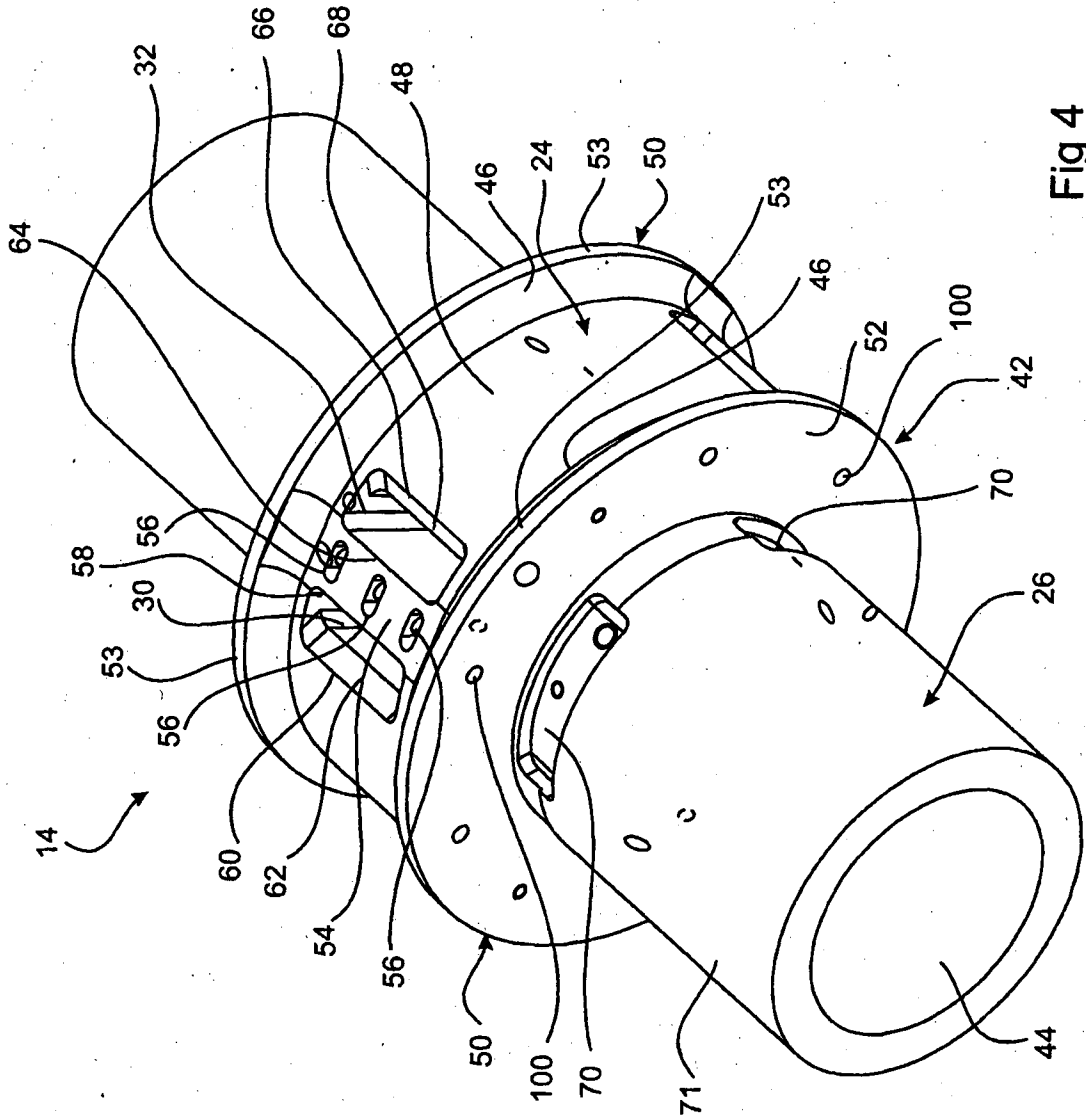

Fig 4

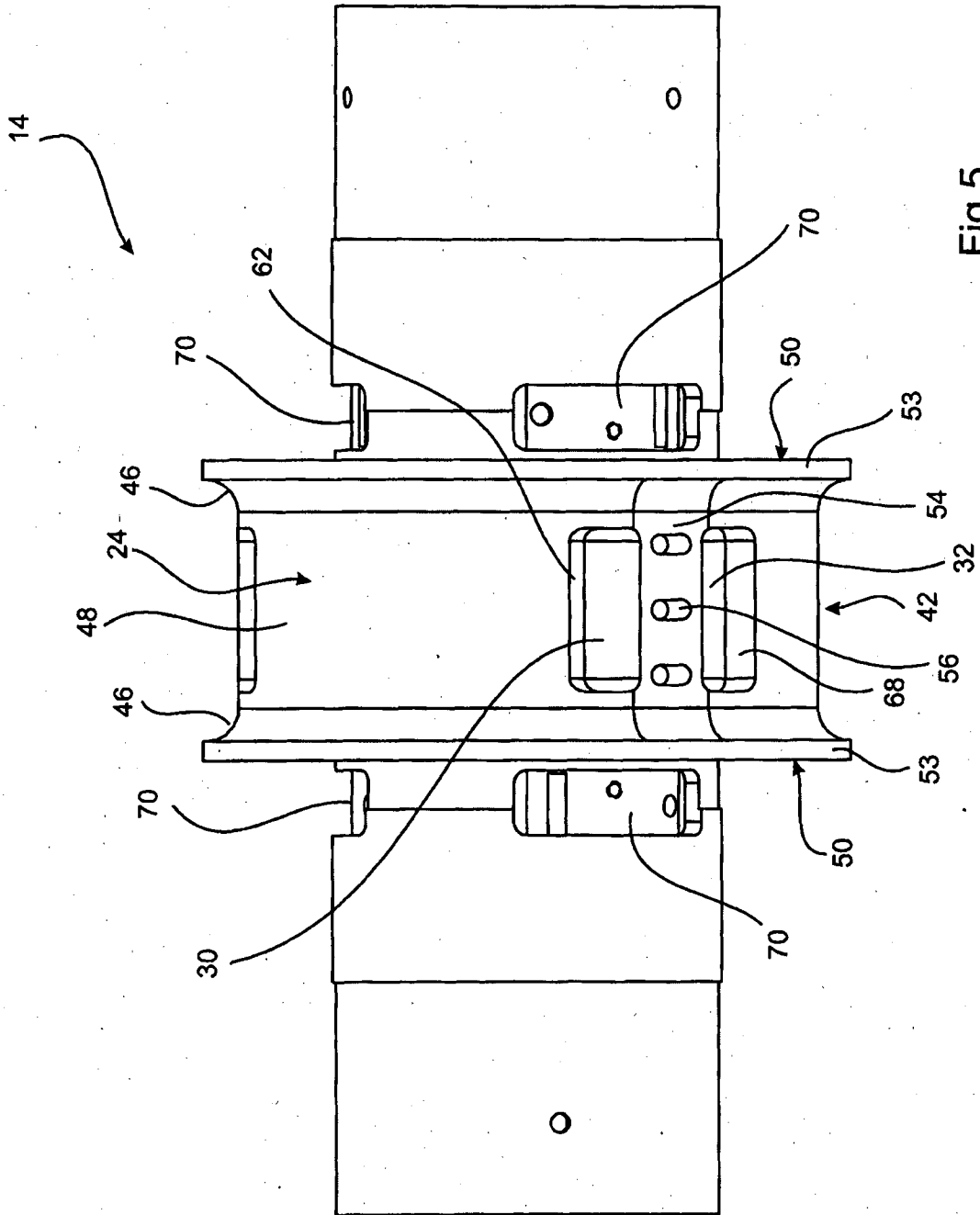

Fig 5

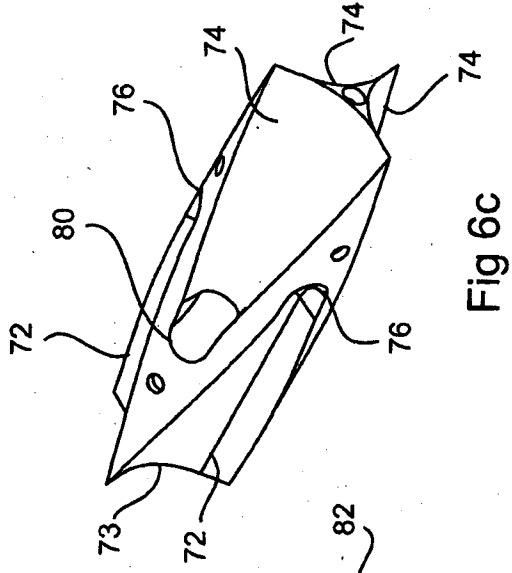

Fig 6c

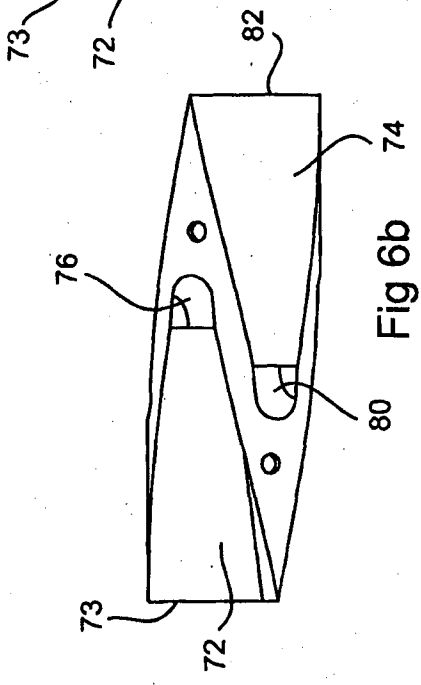

Fig 6b

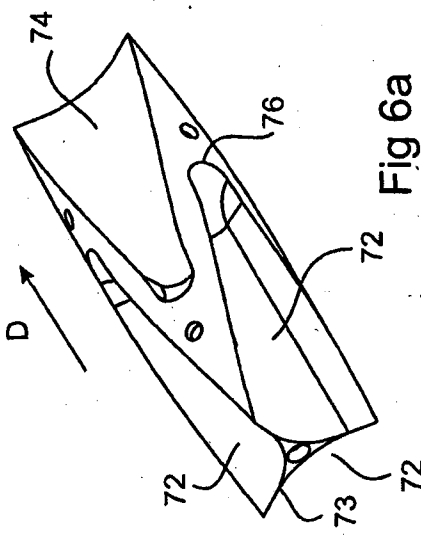

Fig 6a

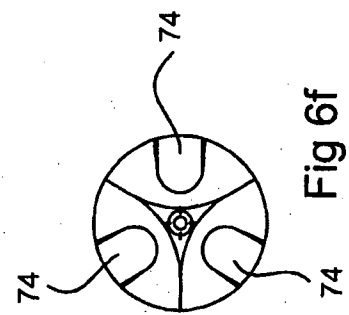

Fig 6f

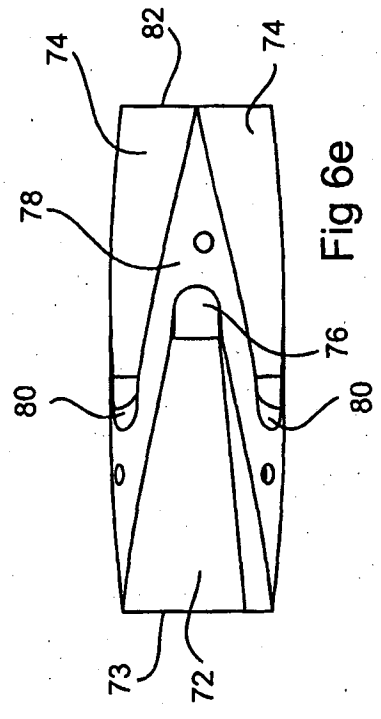

Fig 6e

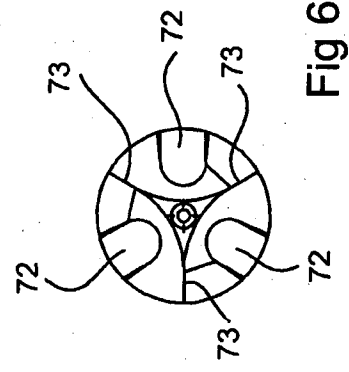

Fig 6d

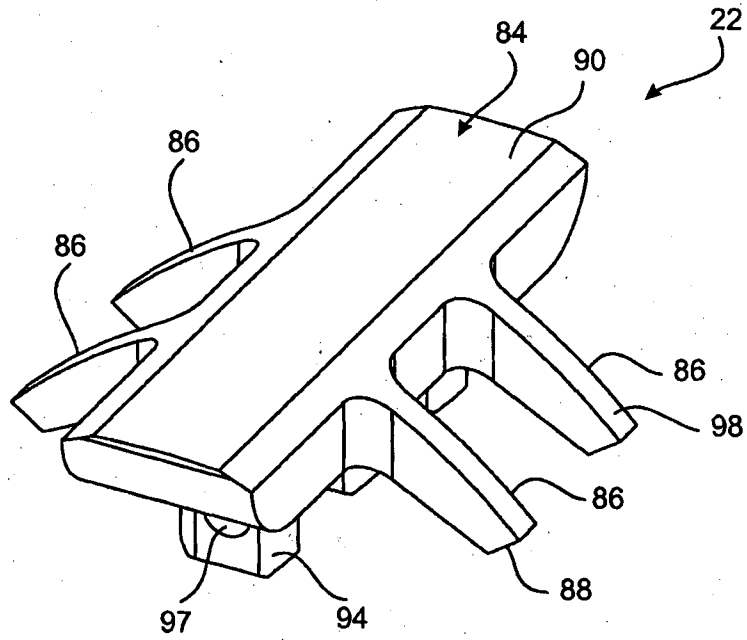

Fig 7a

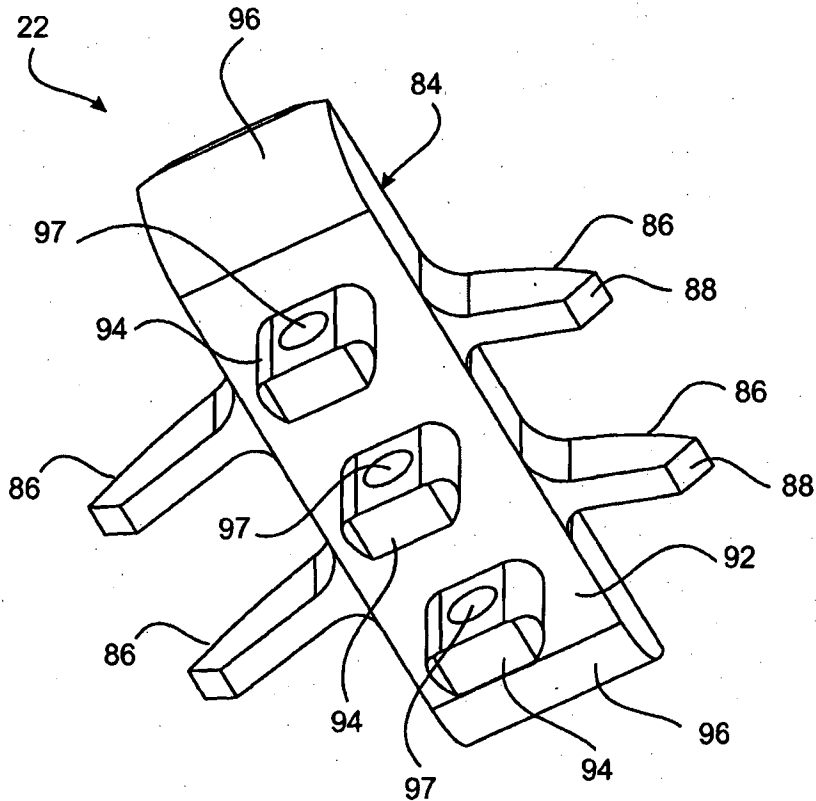
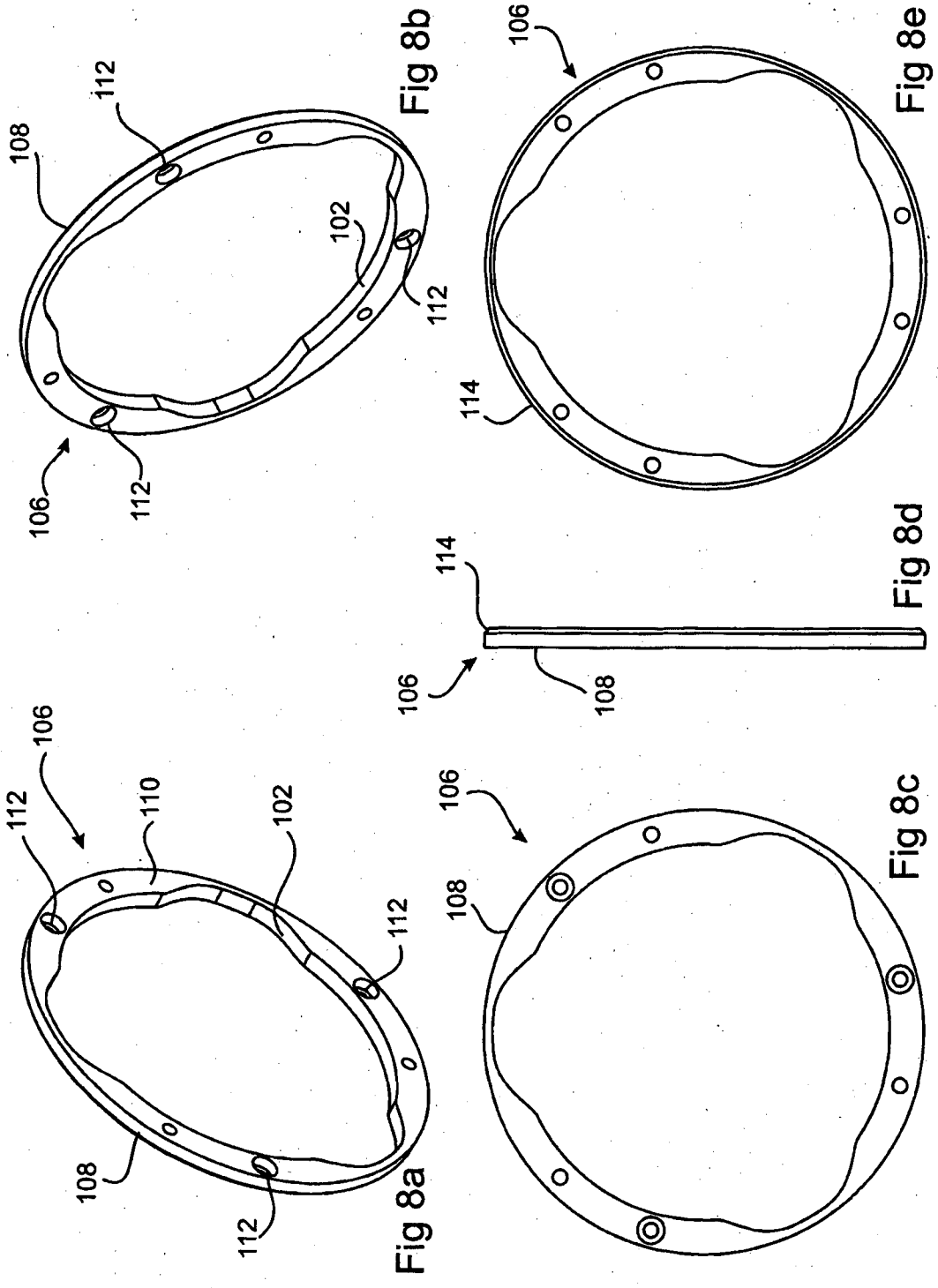
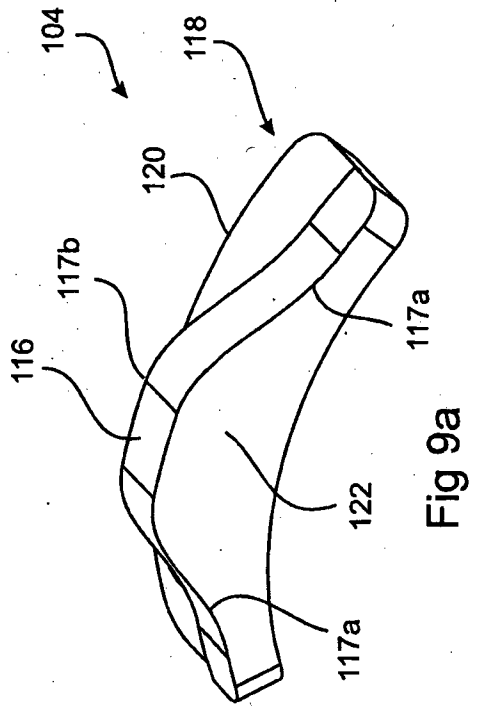
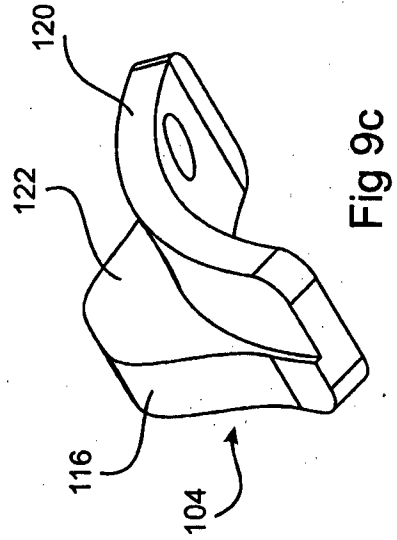
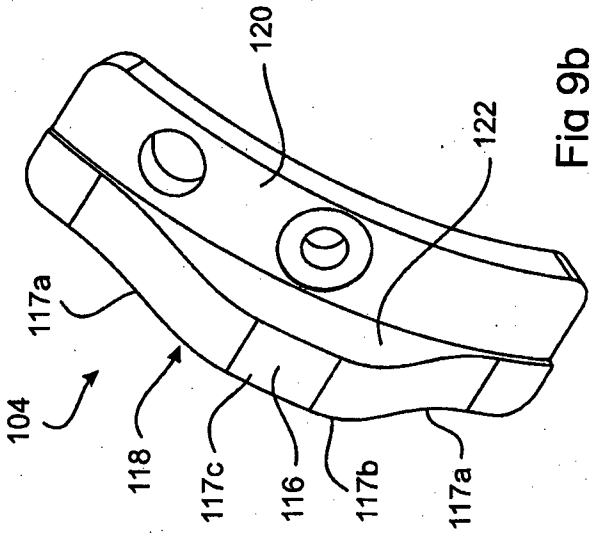

Fig 7b





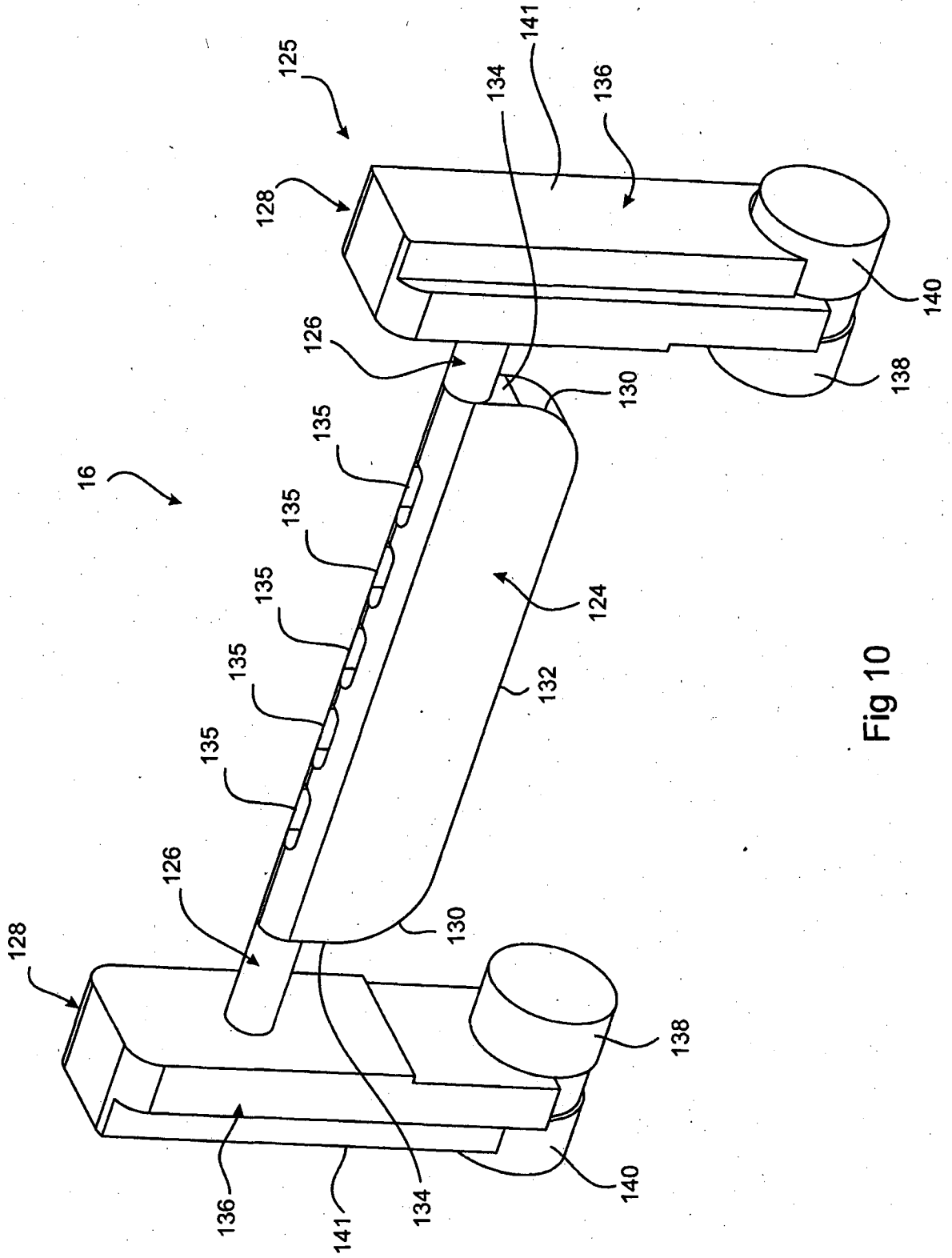

Fig 10

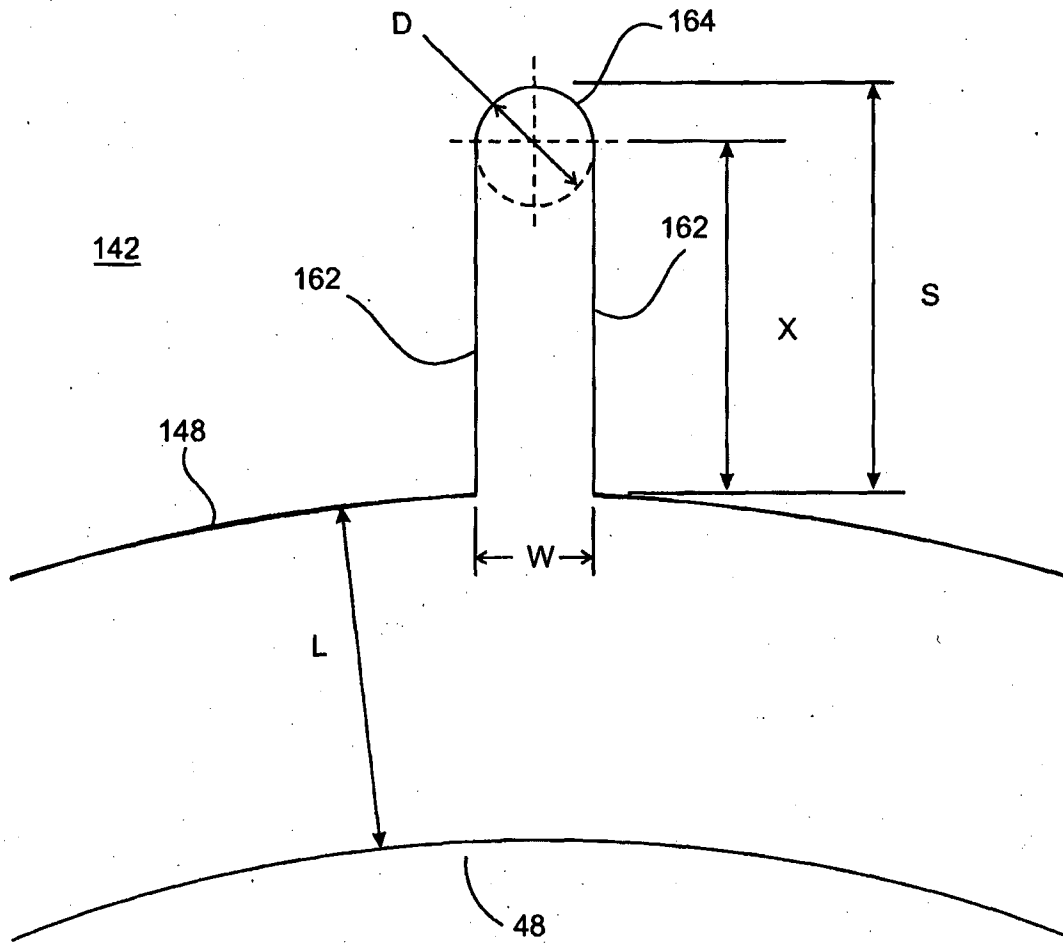

Fig 11c

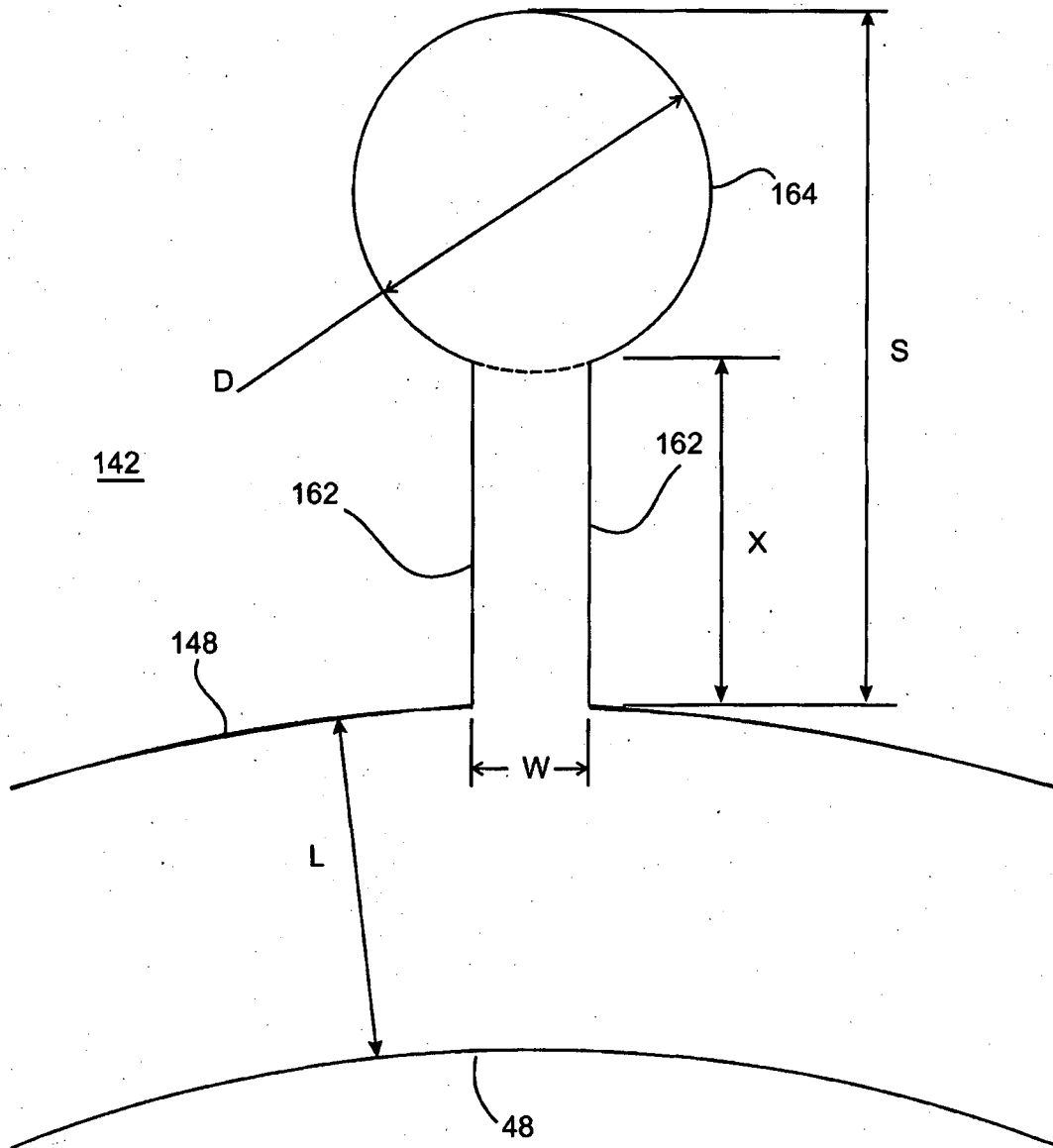
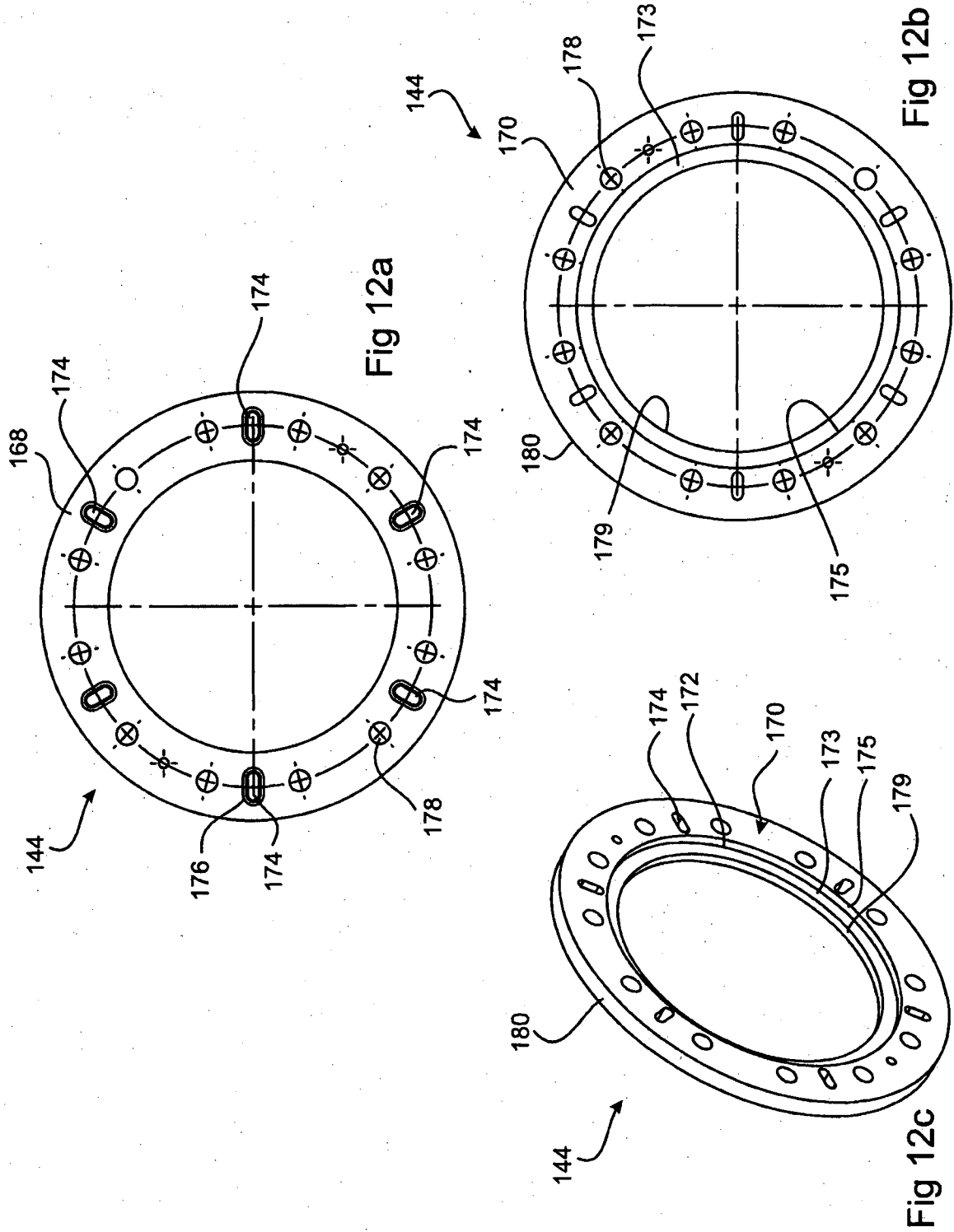

Fig 11d



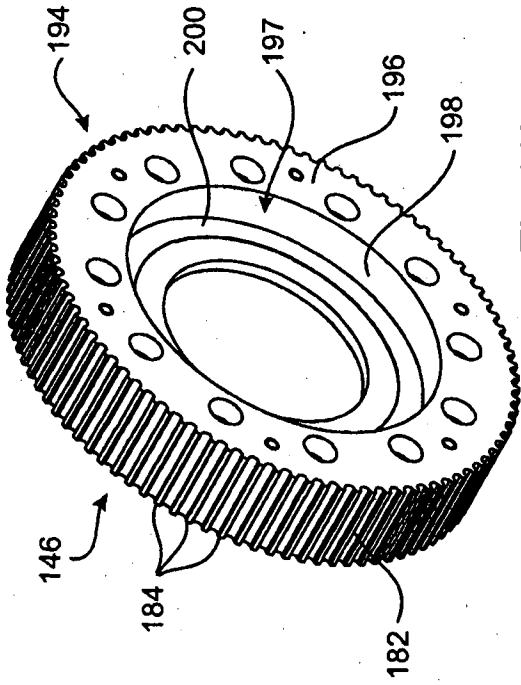

Fig 13b

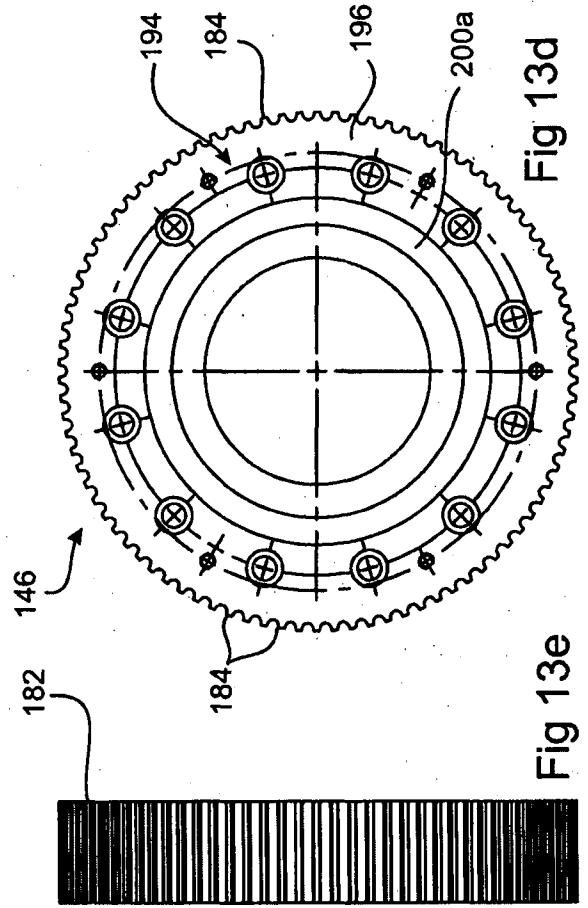

Fig 13d

Fig 13e

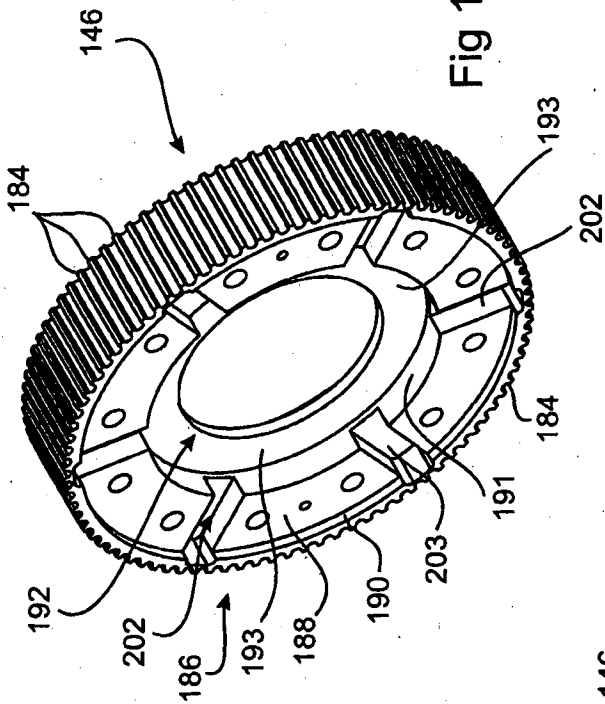

Fig 13a

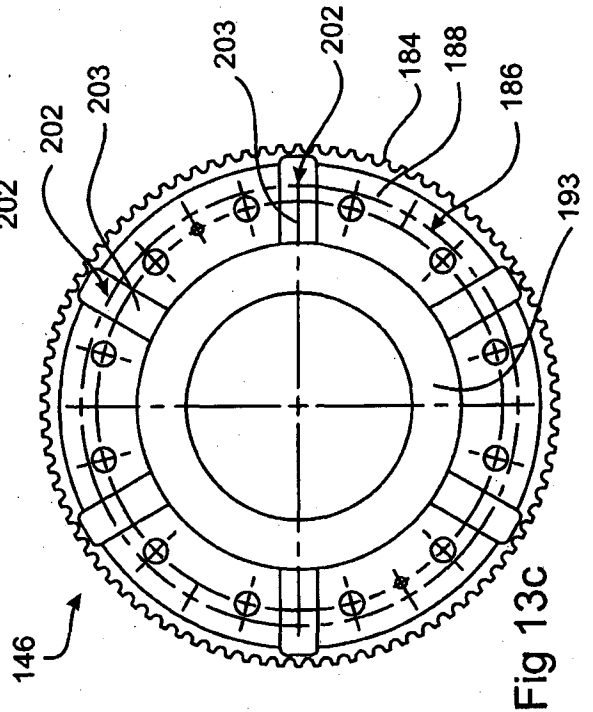

Fig 13c

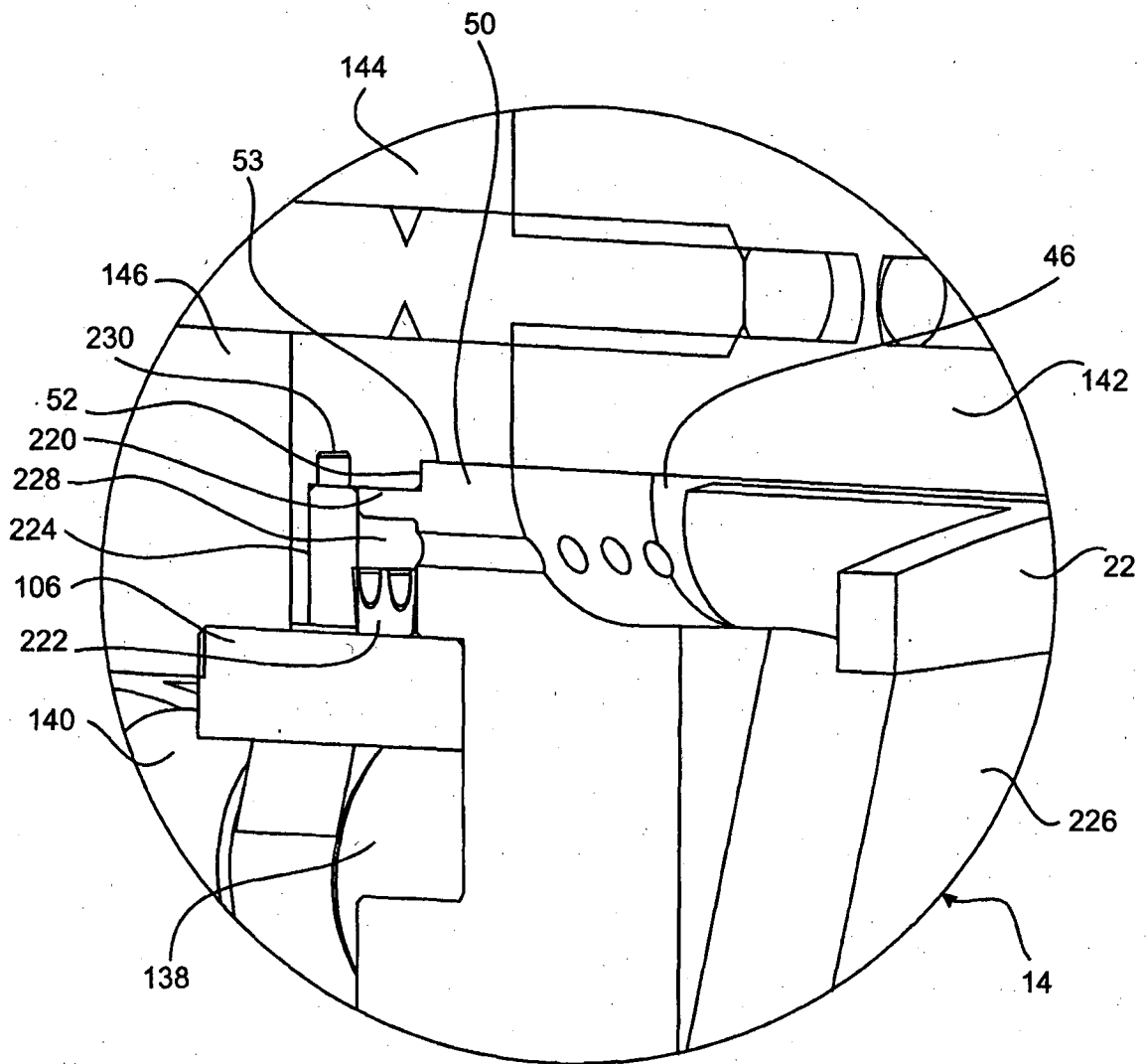

Fig 14

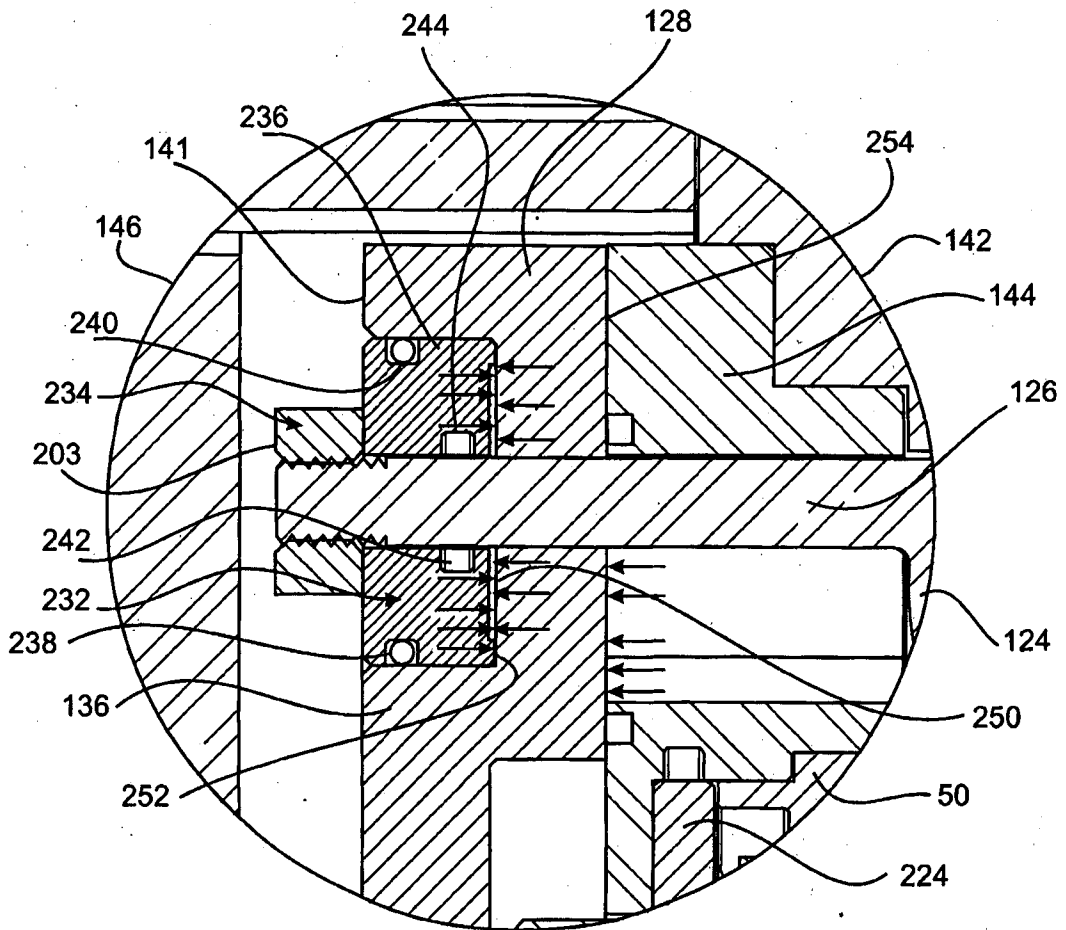

Fig 15

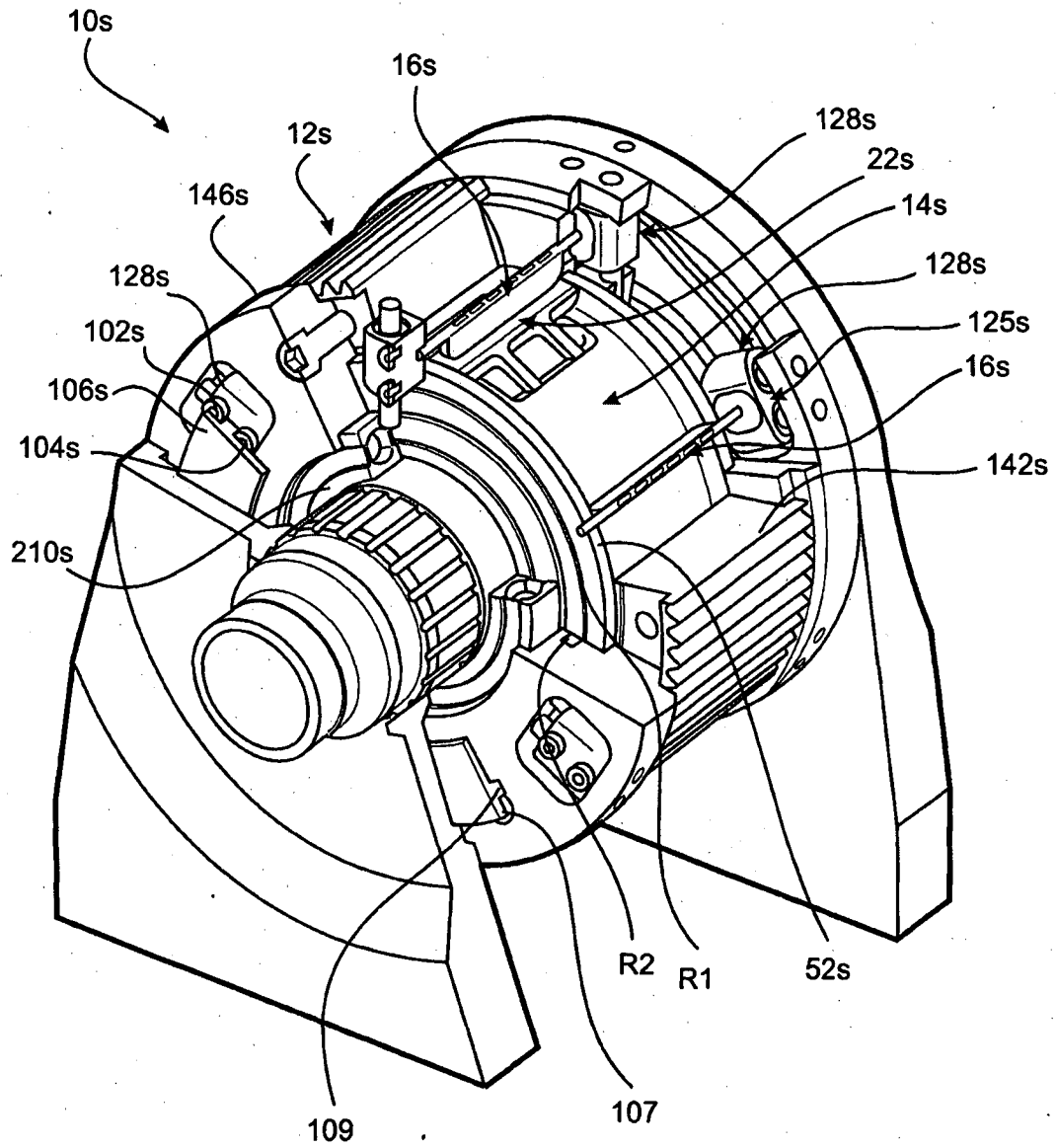

Fig 16

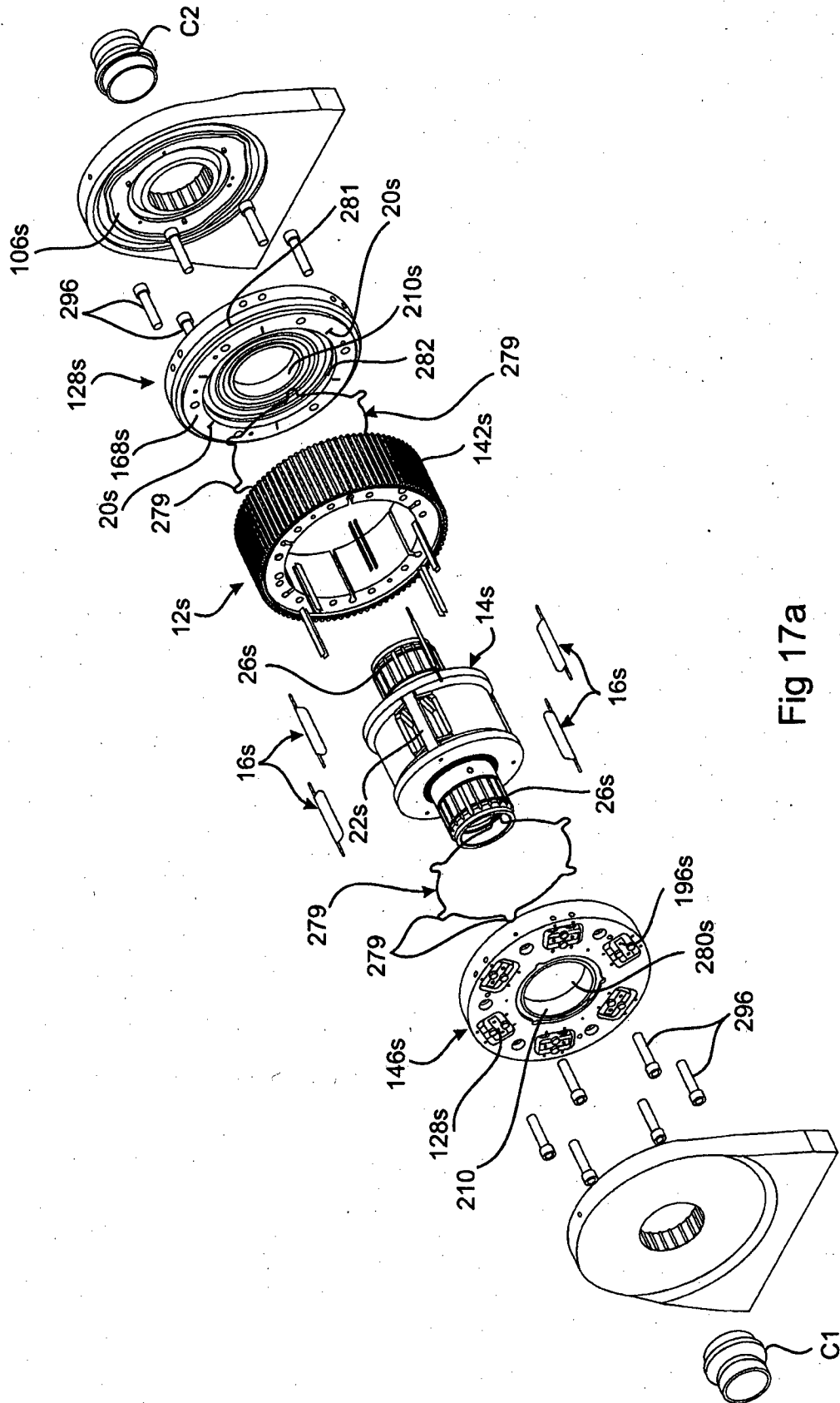

Fig 17a

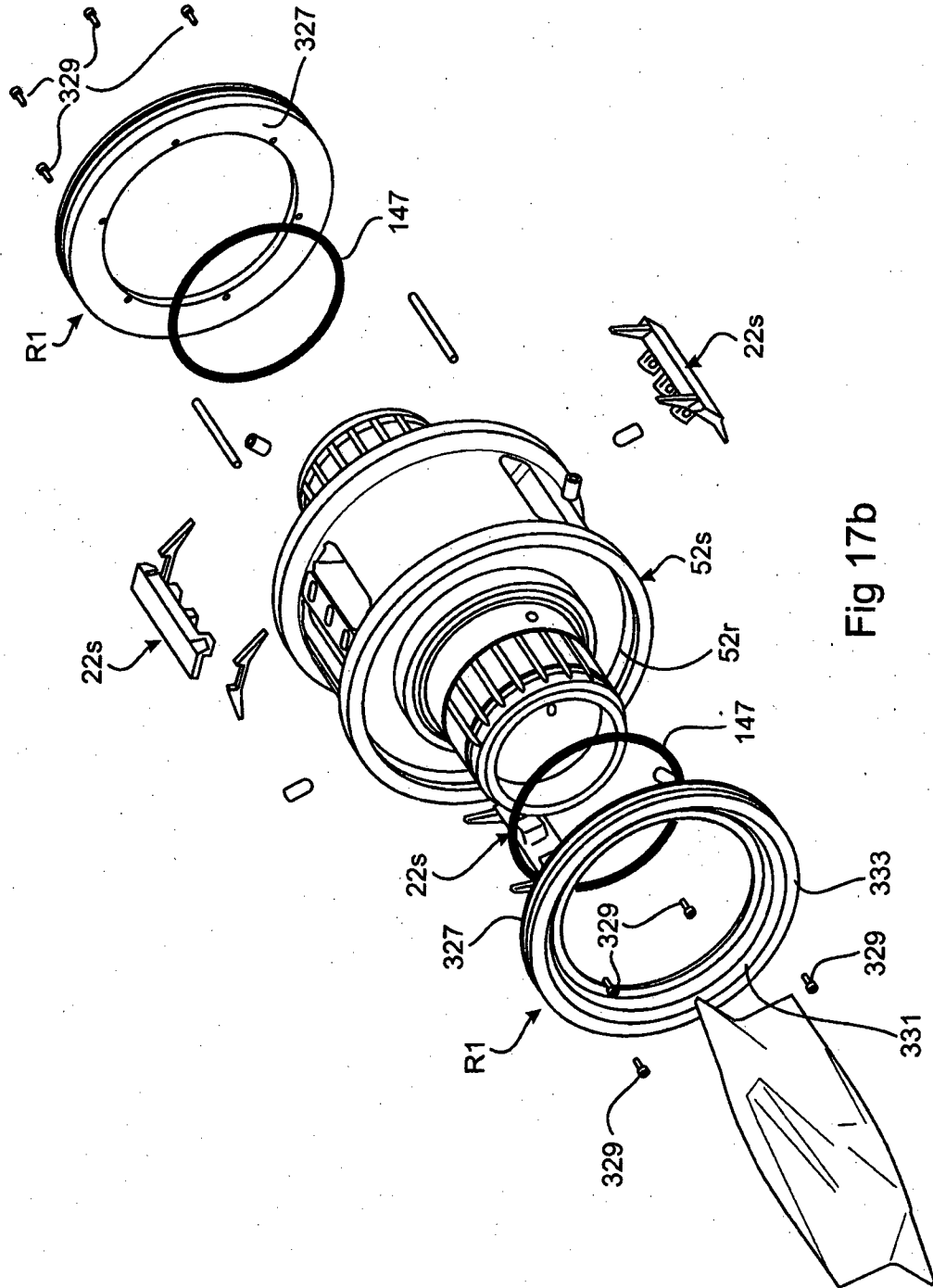

Fig 17b

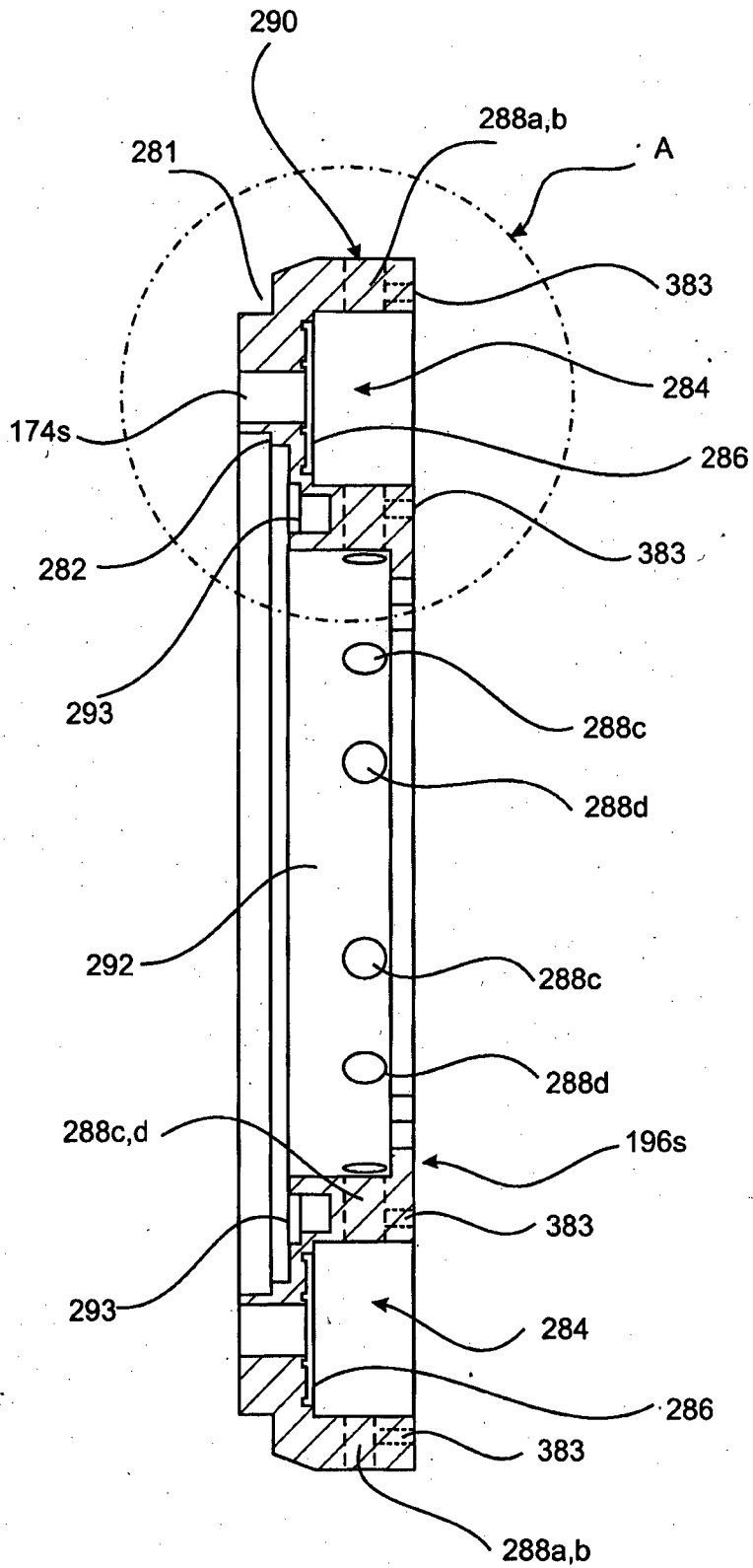

Fig 18b

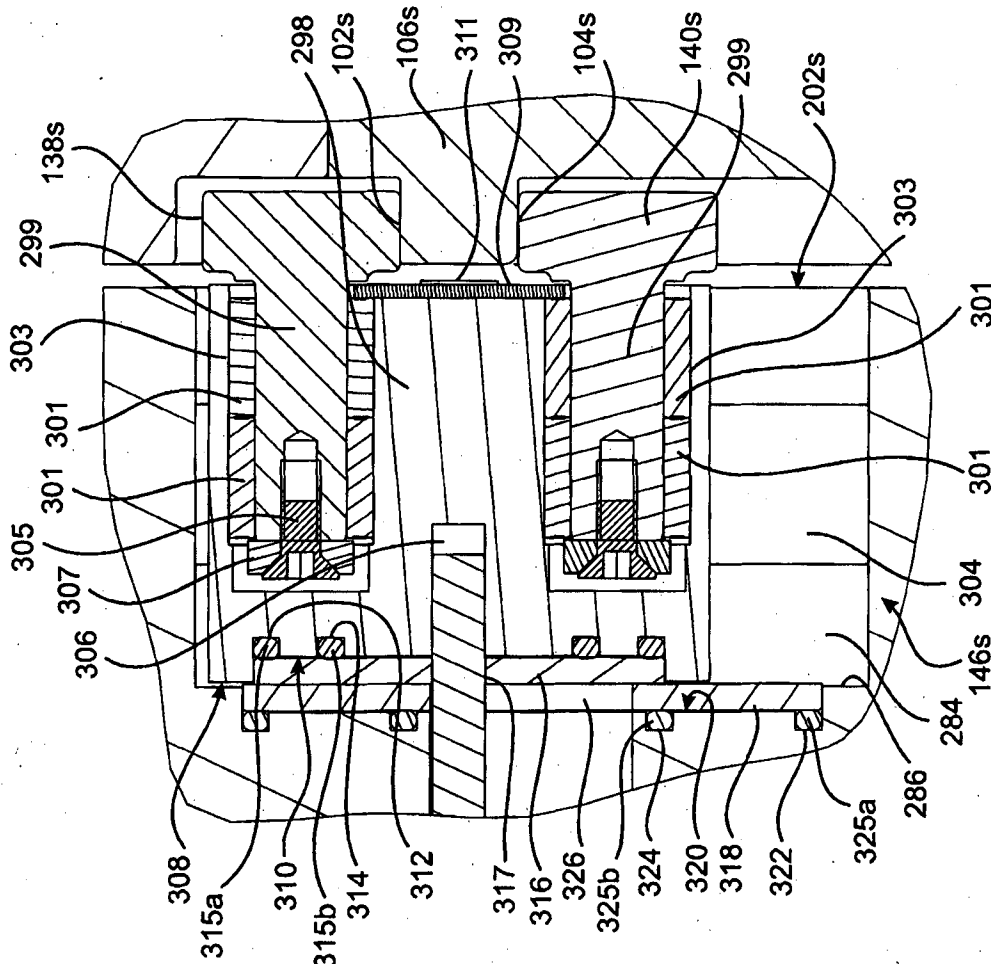

Fig 19b

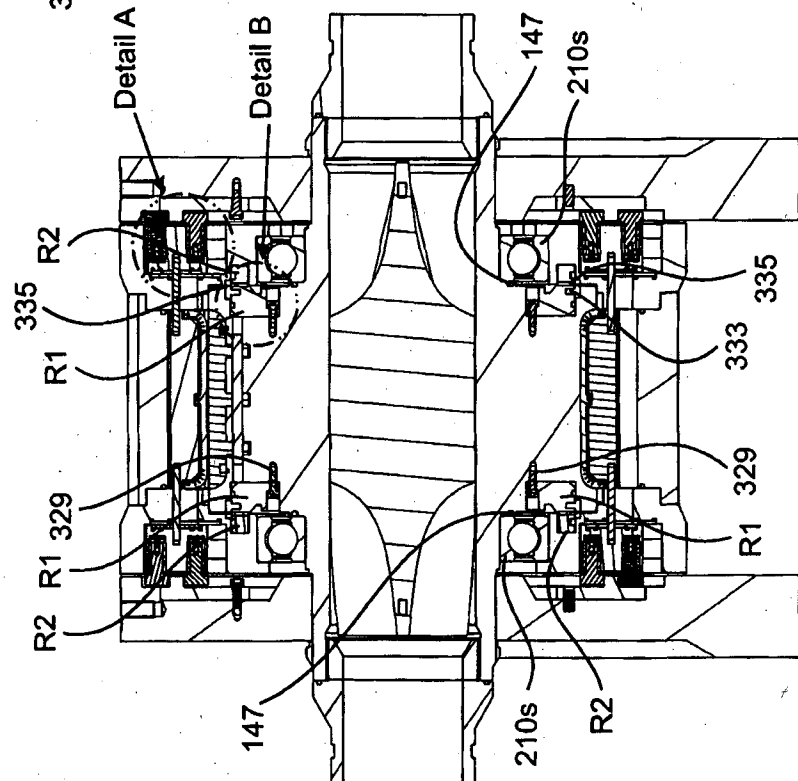

Fig 19a

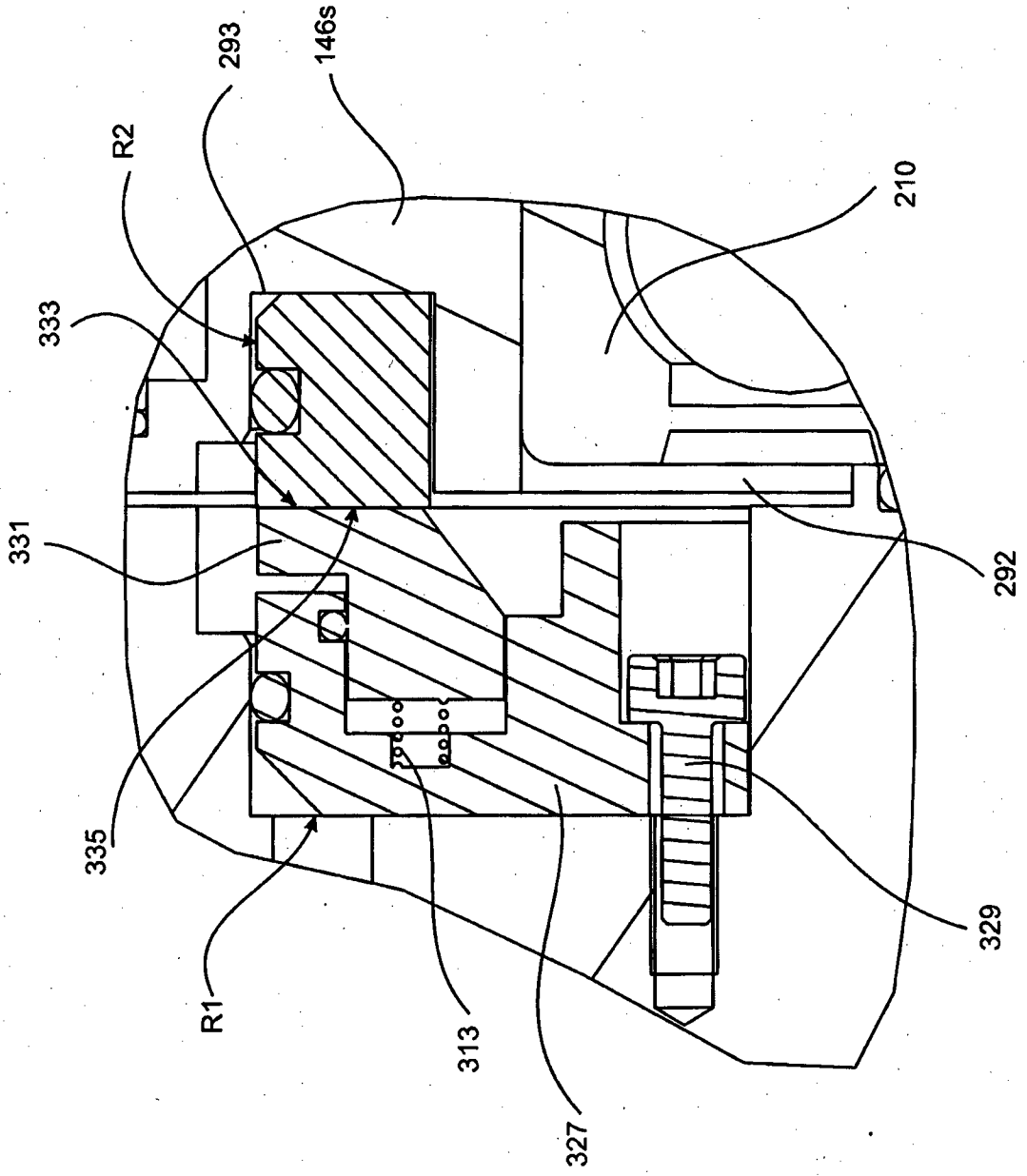
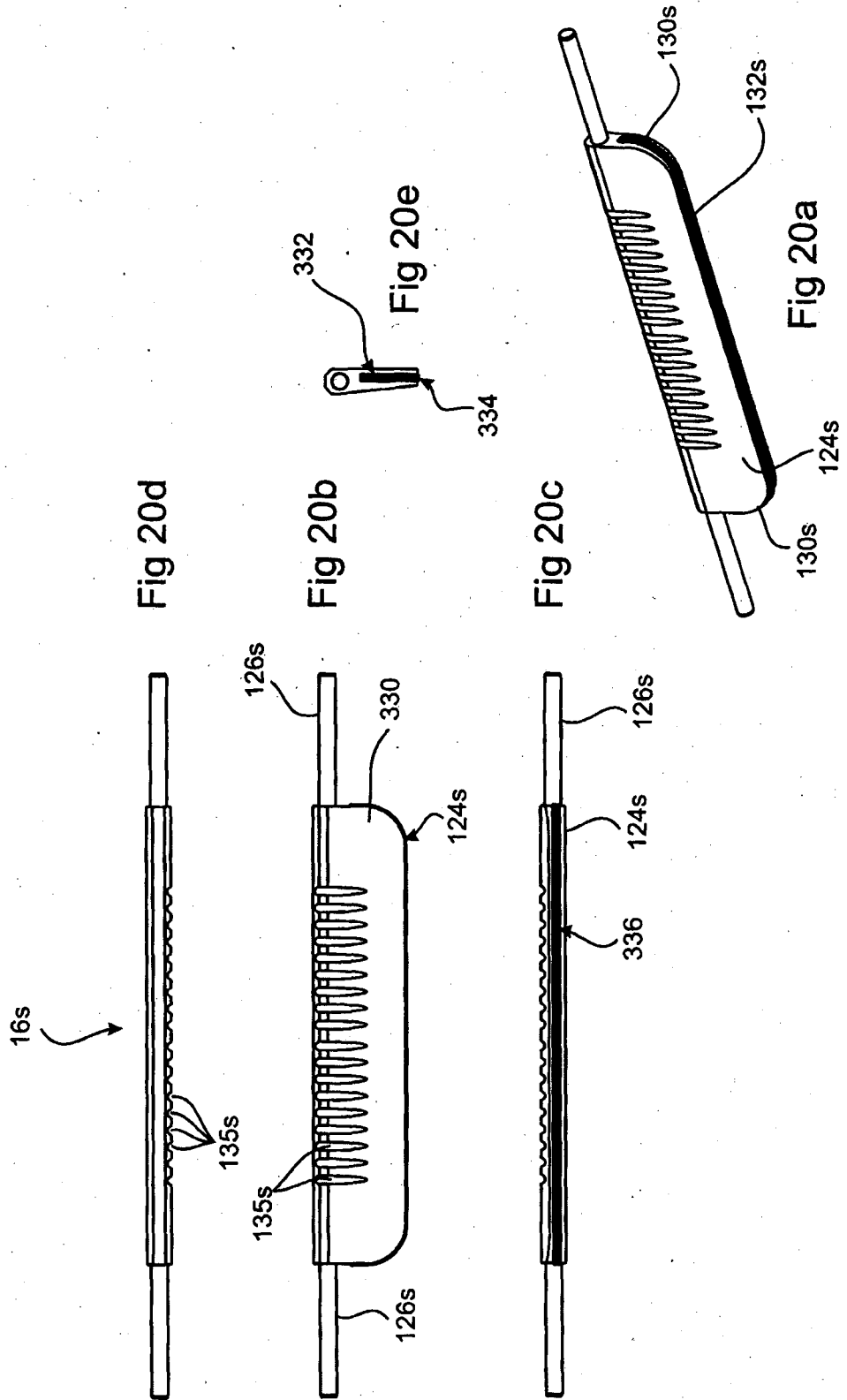

Fig 19c



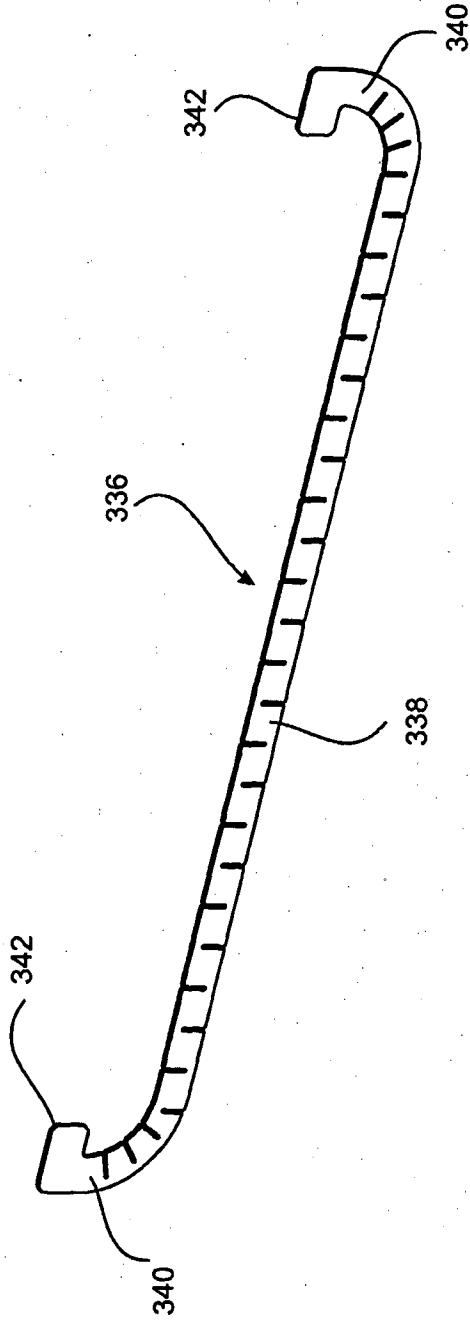

Fig 21a

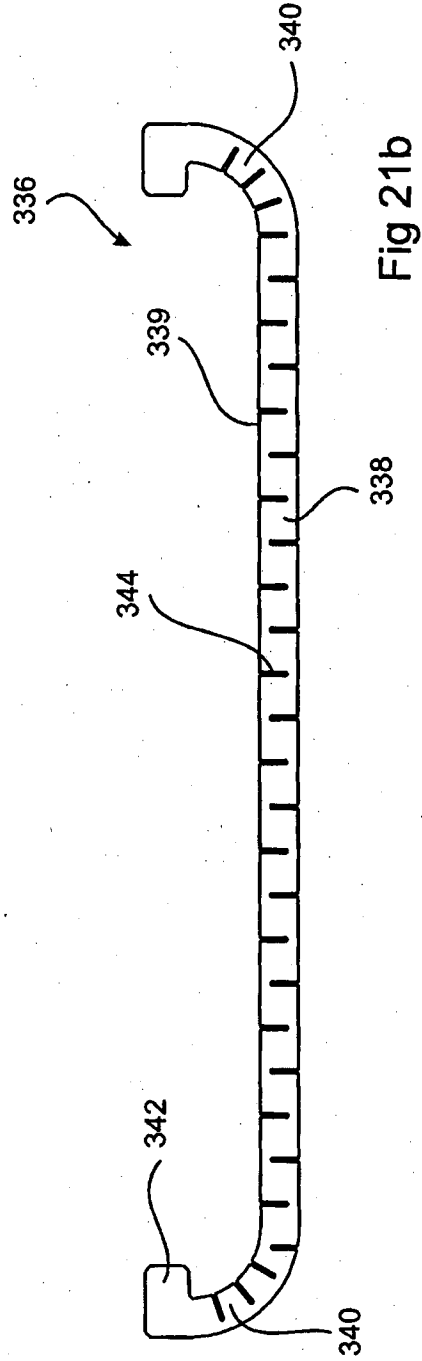

Fig 21b

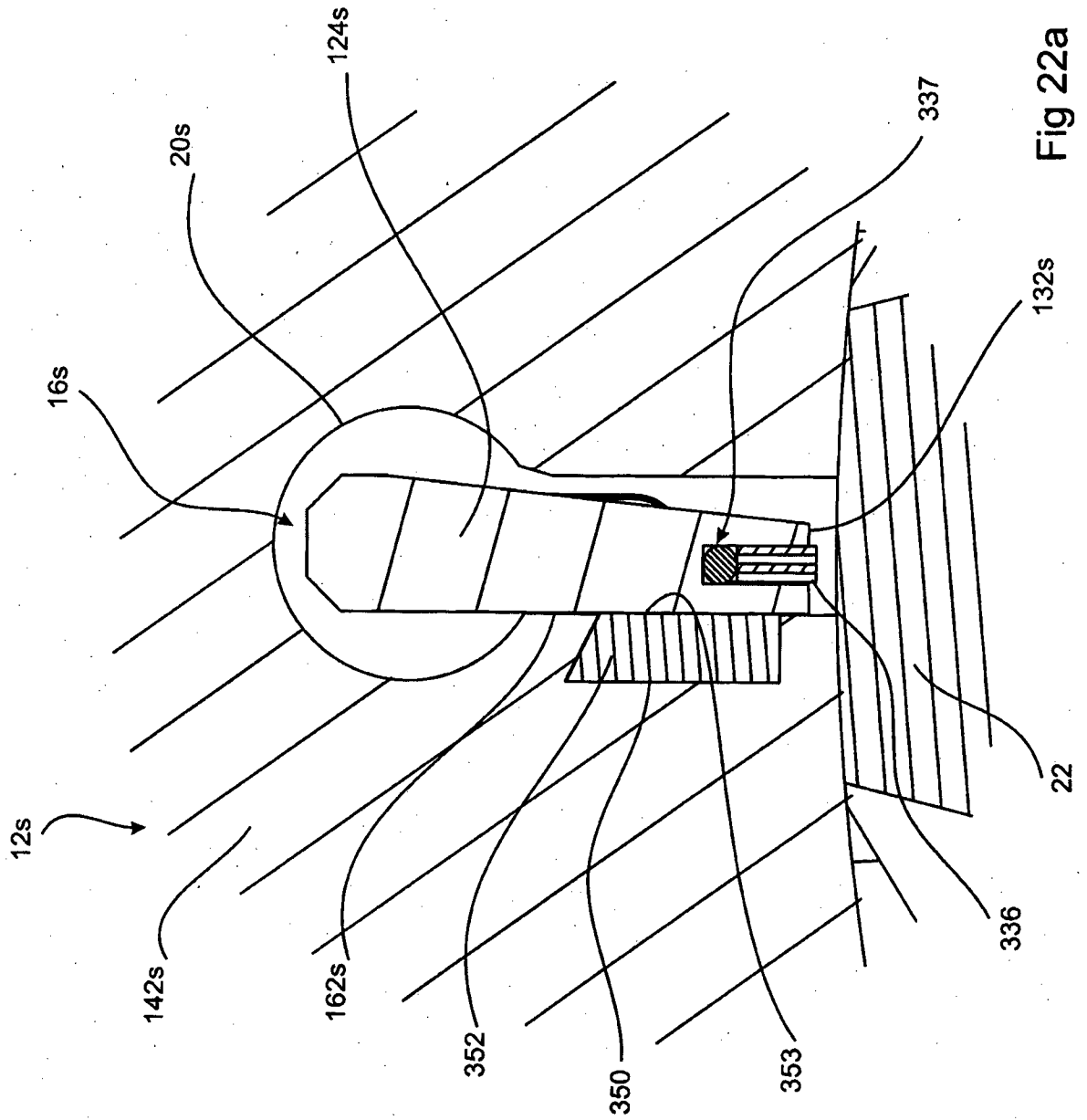

Fig 22a

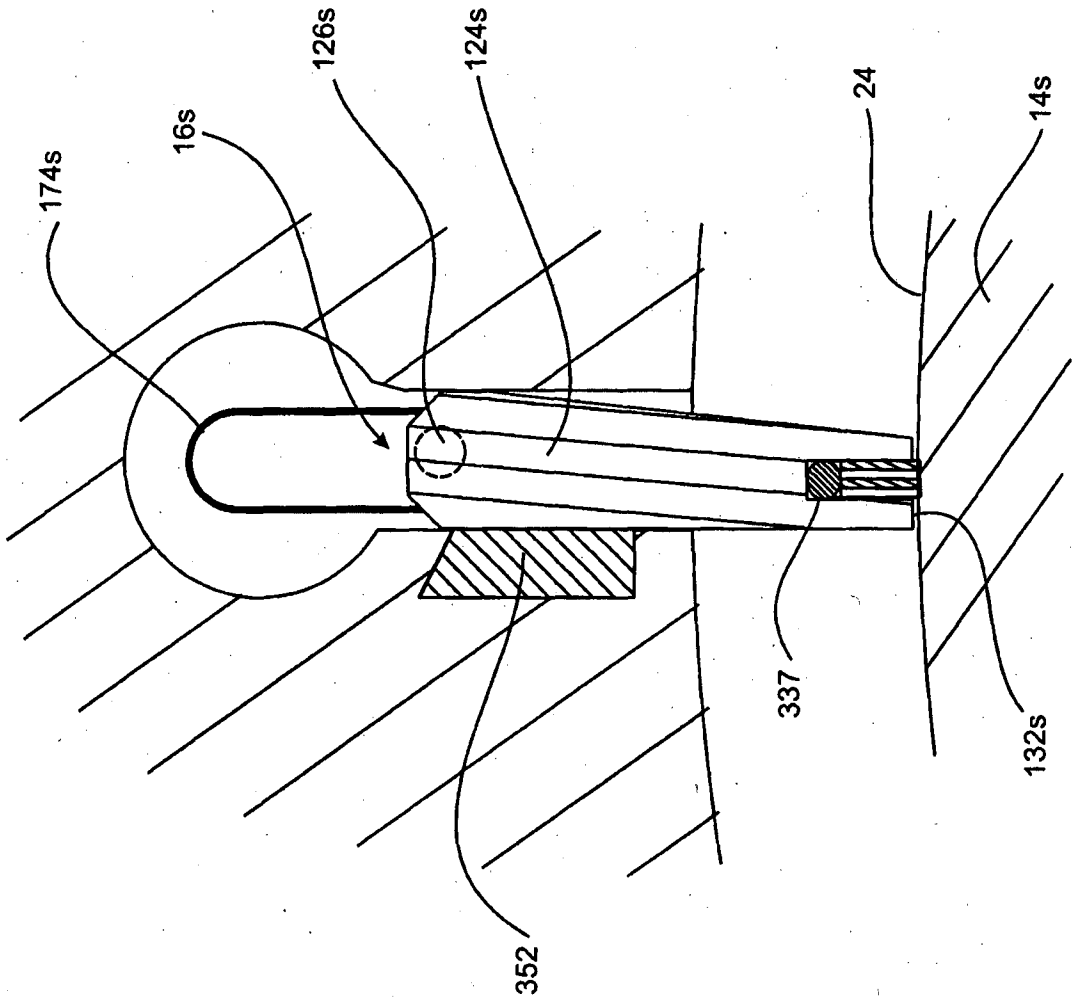
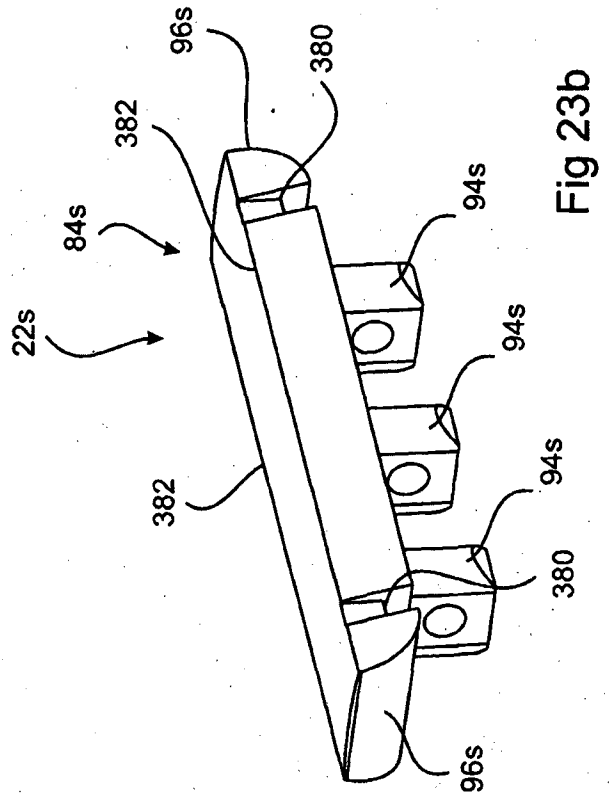
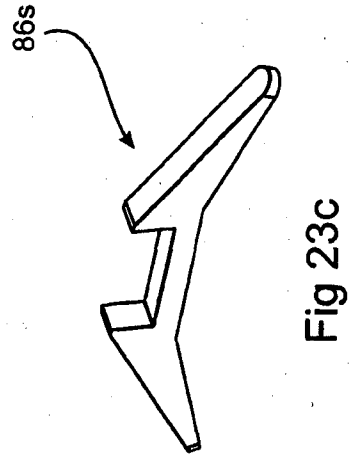
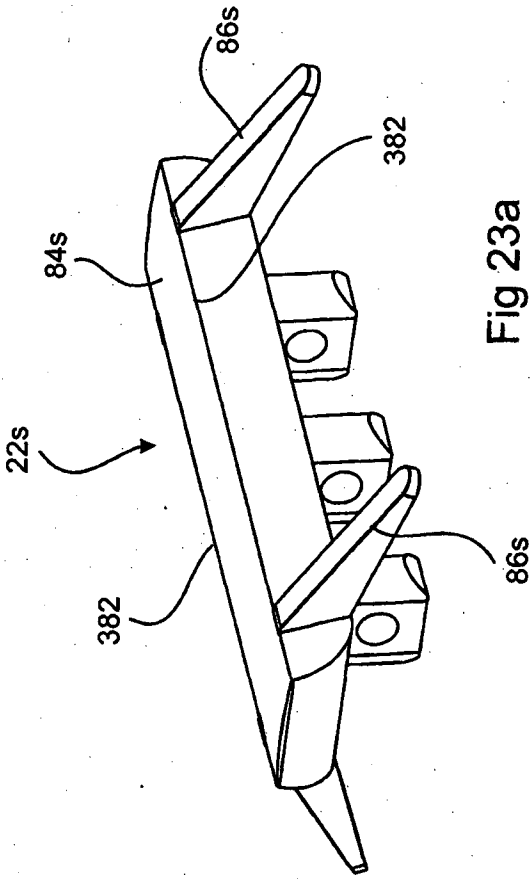

Fig 22b



30 / 33

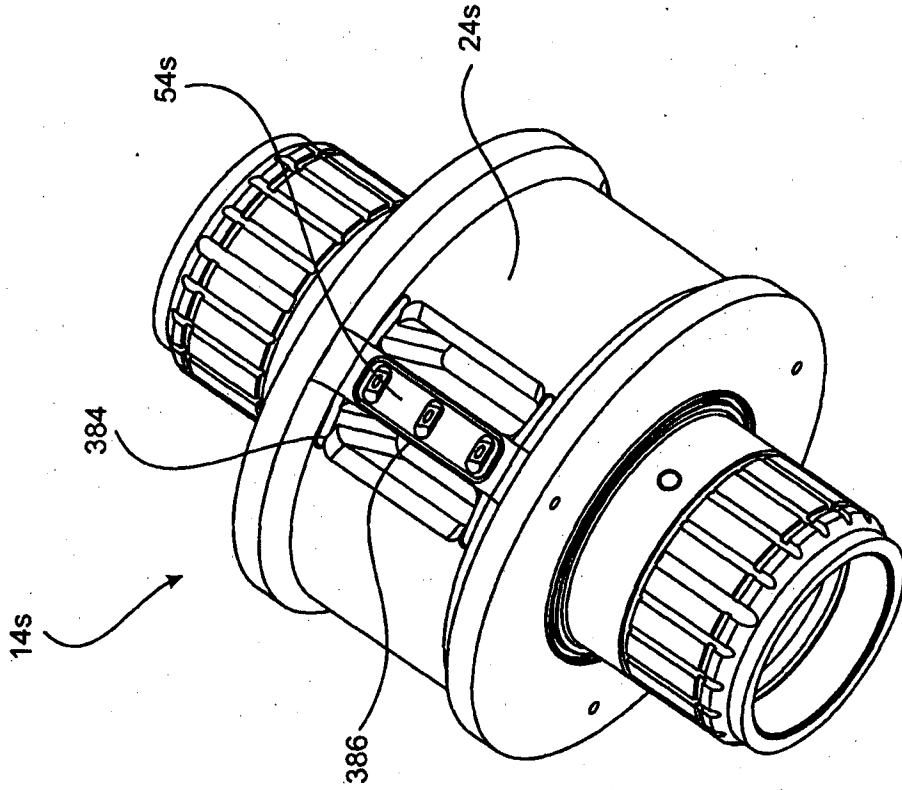

Fig 24b

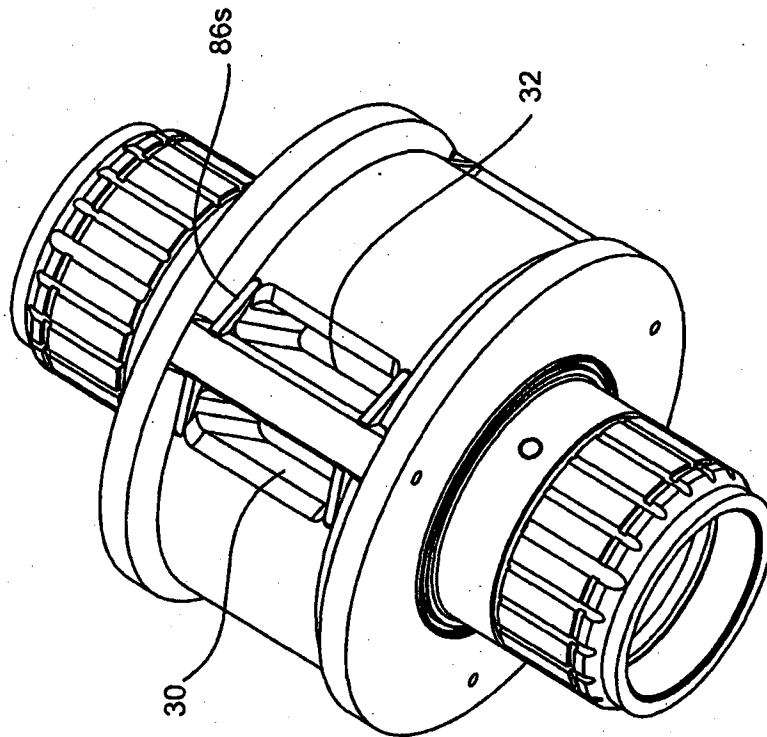

Fig 24a

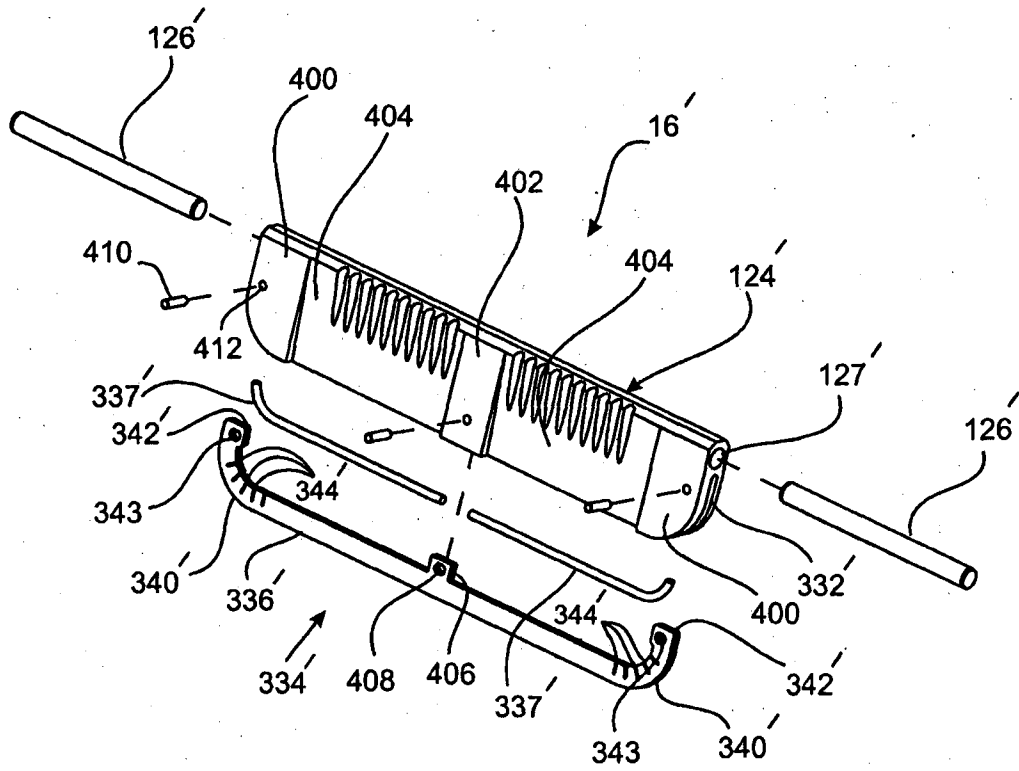

Fig 25a



Fig 25b

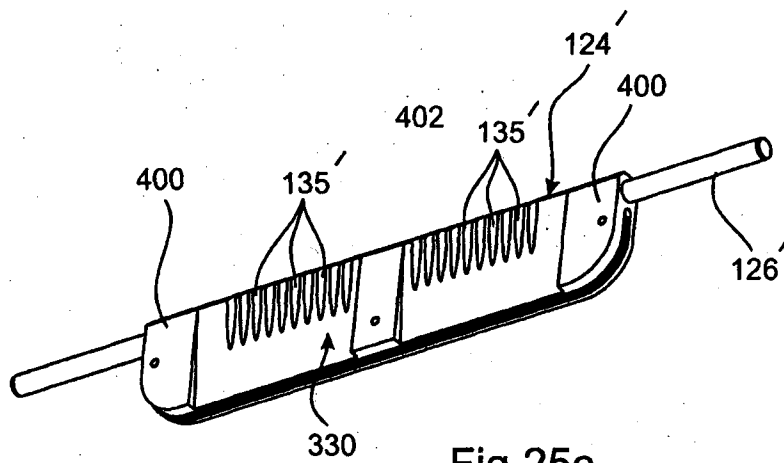

Fig 25c

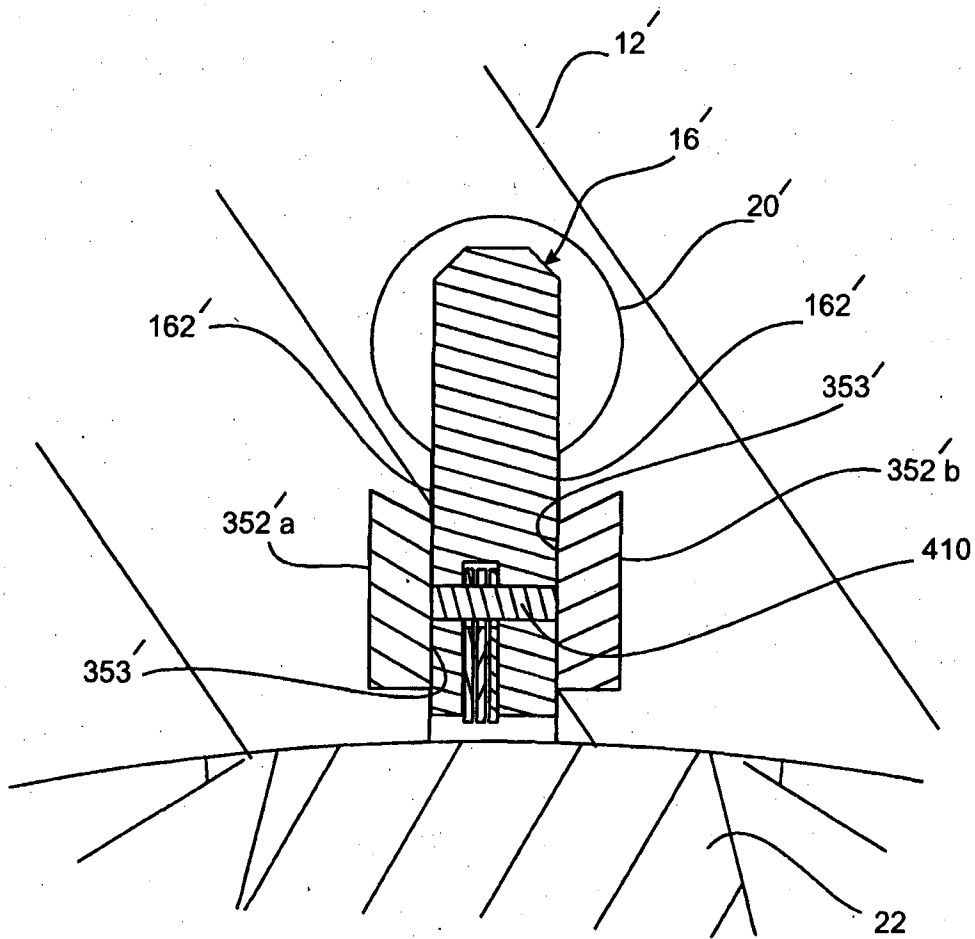

Fig 26a

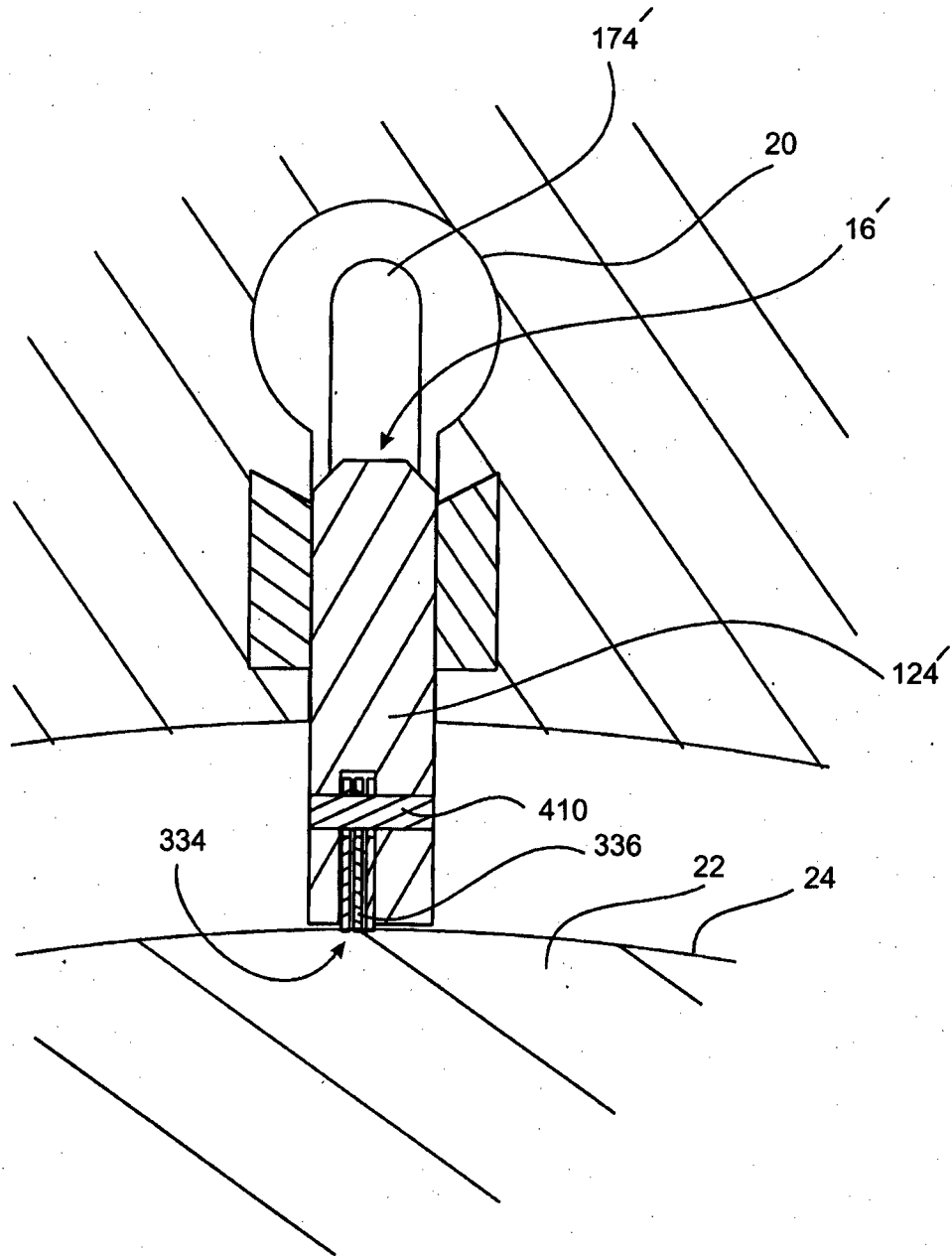

Fig 26b

INTERNATIONAL SEARCH REPORT

International application No.

PCT/AU2012/000822

A. CLASSIFICATION OF SUBJECT MATTER		
F04C 2/40 (2006.01) F04C 18/40 (2006.01) F01C 1/40 (2006.01) F03C 2/30 (2006.01)		
According to International Patent Classification (IPC) or to both national classification and IPC		
B. FIELDS SEARCHED		
Minimum documentation searched (classification system followed by classification symbols)		
Documentation searched other than minimum documentation to the extent that such documents are included in the fields searched		
Electronic data base consulted during the international search (name of data base and, where practicable, search terms used)		
EPODOC, WPI using IPC marks F01C1/40, F04C2/40, F04C18/40, F03C2/30 & keywords (vane, gate, leaf, wipe, round, arcuate, curved, fillet, chamfer, bevel, corner, U-shape, concave, chamber, surface, wall, leak, seal, cam, lobe, mount, demount, remove, attach, rotor, stator, bend, flexible, and similar terms)		
C. DOCUMENTS CONSIDERED TO BE RELEVANT		
Category*	Citation of document, with indication, where appropriate, of the relevant passages	Relevant to claim No.
	Documents are listed in the continuation of Box C	
<input checked="" type="checkbox"/> Further documents are listed in the continuation of Box C <input checked="" type="checkbox"/> See patent family annex		
* "A"	Special categories of cited documents: document defining the general state of the art which is not considered to be of particular relevance	"T" later document published after the international filing date or priority date and not in conflict with the application but cited to understand the principle or theory underlying the invention
"E"	earlier application or patent but published on or after the international filing date	"X" document of particular relevance; the claimed invention cannot be considered novel or cannot be considered to involve an inventive step when the document is taken alone
"L"	document which may throw doubts on priority claim(s) or which is cited to establish the publication date of another citation or other special reason (as specified)	"Y" document of particular relevance; the claimed invention cannot be considered to involve an inventive step when the document is combined with one or more other such documents, such combination being obvious to a person skilled in the art
"O"	document referring to an oral disclosure, use, exhibition or other means	"&" document member of the same patent family
"P"	document published prior to the international filing date but later than the priority date claimed	
Date of the actual completion of the international search 19 November 2012	Date of mailing of the international search report 19 November 2012	
Name and mailing address of the ISA/AU AUSTRALIAN PATENT OFFICE PO BOX 200, WODEN ACT 2606, AUSTRALIA Email address: pct@ipaustrialia.gov.au Facsimile No.: +61 2 6283 7999	Authorised officer Stuart Ash AUSTRALIAN PATENT OFFICE (ISO 9001 Quality Certified Service) Telephone No. 0399359633	

INTERNATIONAL SEARCH REPORT		International application No.
C (Continuation). DOCUMENTS CONSIDERED TO BE RELEVANT		PCT/AU2012/000822
Category*	Citation of document, with indication, where appropriate, of the relevant passages	Relevant to claim No.
X Y	GB 1286010 A (XOMOX CORPORATION) 16 August 1972 Figures 1 to 3; and page 2, lines 48 to 60. Figures 1 to 3.	1, 3-4, 7-9, 11 2, 5-6, 10, 15-16, 18-20, 26-27, 29-44
Y	WO 1998/016744 A1 (MERLIN CORPORATION PTY LTD) 23 April 1998 Abstract; figures 1 to 4; page 4, lines 1 to 6; claim 8.	2, 5-6, 18-20, 26-27, 29-44
Y A	US 3134335 A (JENSEN) 26 May 1964 Figure 1. Figures 1 and 6	2, 5-6, 15-16, 18 40-41
Y	US 1269937 A (HUTSELL) 18 June 1918 Page 2, lines 40 to 46; figure 6.	10
A	ROHNER, P., 'Industrial Hydraulic Control: a Textbook for Fluid Power Technicians', 1995, 4th ed., ISBN 0-471-33524-X, pages 36 to 37 Figure 62	42-44
P,X	WO 2011/088596 A1 (CHOU) 28 July 2011 Figures 1, 2, 5 and 6	1-5, 7-9, 11, 18

Box No. II Observations where certain claims were found unsearchable (Continuation of item 2 of first sheet)

This international search report has not been established in respect of certain claims under Article 17(2)(a) for the following reasons:

1. Claims Nos.:
because they relate to subject matter not required to be searched by this Authority, namely:

2. Claims Nos.:
because they relate to parts of the international application that do not comply with the prescribed requirements to such an extent that no meaningful international search can be carried out, specifically:

3. Claims Nos.:
because they are dependent claims and are not drafted in accordance with the second and third sentences of Rule 6.4(a)

Box No. III Observations where unity of invention is lacking (Continuation of item 3 of first sheet)

This International Searching Authority found multiple inventions in this international application, as follows:

See Supplemental Box for Details

1. As all required additional search fees were timely paid by the applicant, this international search report covers all searchable claims.
2. As all searchable claims could be searched without effort justifying additional fees, this Authority did not invite payment of additional fees.
3. As only some of the required additional search fees were timely paid by the applicant, this international search report covers only those claims for which fees were paid, specifically claims Nos.:

4. No required additional search fees were timely paid by the applicant. Consequently, this international search report is restricted to the invention first mentioned in the claims; it is covered by claims Nos.:
1-44

Remark on Protest

- The additional search fees were accompanied by the applicant's protest and, where applicable, the payment of a protest fee.
- The additional search fees were accompanied by the applicant's protest but the applicable protest fee was not paid within the time limit specified in the invitation.
- No protest accompanied the payment of additional search fees.

Supplemental Box**Continuation of: Box III**

This International Application does not comply with the requirements of unity of invention because it does not relate to one invention or to a group of inventions so linked as to form a single general inventive concept.

This Authority has found that there are different inventions based on the following features that separate the claims into distinct groups:

- Claims 1 to 44 relate to a rotary fluid machine comprising, two bodies rotatably relative to one another, the first body supporting at least one planar gate having rounded corners at each axially spaced end; the second body having a circumferential surface forming part of the working chamber having a U-shaped profile, such that the gate and U-shaped profile lie closely adjacent to and substantially parallel with each other. The feature of a gate having rounded corners complementing a U-shaped profile of circumferential surface of a body is specific to this first group of claims.
- Claims 45 to 62 relate to a body of a fluid rotary machine (60 to 62 being to a rotary machine itself), wherein a body comprises one or more pairs of ports, each pair comprising an inlet and an outlet port, one or more demountable lobes coupled to the body and projecting from a surface thereof between inlet and outlet ports of one of the pairs, the lobes comprising a central portion and a ramp extending from each side of the central portion to the surface, thereby providing a transition between the circumferential surface to an upper surface of the central portion. The feature of pairs of ports and ramped lobes is specific to this second group of claims.
- Claims 63 to 72 relate to a body for a fluid rotary machine comprising a radially extending gate slot having two spaced apart and parallel flat surfaces, the gate slot extends at one end to a circumferential surface of the body and a contiguous arcuate portion extends between respective distant ends of the flat surfaces thus forming a blind end of the gate slot. The feature of a gate slot having a contiguous arcuate portion extending between respective distant ends of flat surfaces is specific to this third group of claims.
- Claims 73 to 87 relate to a rotary fluid machine comprising two bodies rotatably relative to one another, the first body provided with a radial gate slot and a gate movable therein, a displacement mechanism operable to displace the gate into the gate slot; the gate further comprising, two gate links on each side, and cam surfaces disposed outside of the working chamber arranged to move the gate links radially as the first and second bodies rotate relative to each other. The feature of a displacement mechanism comprising two gate links on each side of a gate, and cam surfaces arranged to move the gate links radially is specific to this fourth group of claims.
- Claims 88 to 98 relate to a gate suitable for a rotary fluid machine having two bodies rotatably relative to one another, the first body provided with a radial gate slot, the gate comprising a wiper and a sealing system arranged to form a dynamic seal against a circumferential surface of the second body. The feature of the gate comprising a wiper and a sealing system is specific to this fifth group of claims.

PCT Rule 13.2, first sentence, states that unity of invention is only fulfilled when there is a technical relationship among the claimed inventions involving one or more of the same or corresponding special

Supplemental Box

technical features. PCT Rule 13.2, second sentence, defines a special technical feature as a feature which makes a contribution over the prior art.

When there is no special technical feature common to all the claimed inventions there is no unity of invention.

In the above groups of claims, the identified features may have the potential to make a contribution over the prior art but are not common to all the claimed inventions and therefore cannot provide the required technical relationship. Therefore there is no special technical feature common to all the claimed inventions and the requirements for unity of invention are consequently not satisfied *a priori*.

Additionally, it has been found that a further lack of unity exists within the first group of claims. Different inventions separate these claims into distinct sub-groups.

- Claims 1 to 6 are directed to the general structure of a rotary fluid machine comprising gates having rounded corners that are complementary with a U-shaped profile of a circumferential surface of a body.
- Claims 7 to 14 are directed to a sealing arrangement comprising a movable wiper of a rotary fluid machine, the machine comprising gates having rounded corners that are complementary with a U-shaped profile of a circumferential surface of a body.
- Claims 15 to 17 are directed to fluid channels incorporated into the gates of a rotary fluid machine comprising gates having rounded corners that are complementary with a U-shaped profile of a circumferential surface of a body.
- Claims 18 to 33 are directed to a gate displacement system for a rotary fluid machine comprising gates having rounded corners that are complementary with a U-shaped profile of a circumferential surface of a body.
- Claims 34 to 44 are directed to the porting arrangement of a rotary fluid machine comprising gates having rounded corners that are complementary with a U-shaped profile of a circumferential surface of a body.

In the above sub-groups of claims, the only feature common to all of the claimed inventions and which provides a technical relationship among them is a rotary fluid machine comprising gates having rounded corners that are complementary with a U-shaped profile of a circumferential surface of a body. However this feature does not make a contribution over the prior art because it is disclosed in:

GB 1286010 A (XOMOX CORPORATION) 16 August 1972

Therefore in the light of this document this common feature cannot be a special technical feature. Therefore there is no special technical feature common to all the claimed inventions and the requirements for unity of invention are consequently not satisfied *a posteriori*.

INTERNATIONAL SEARCH REPORT

Information on patent family members

International application No.

PCT/AU2012/000822

This Annex lists known patent family members relating to the patent documents cited in the above-mentioned international search report. The Australian Patent Office is in no way liable for these particulars which are merely given for the purpose of information.

Patent Document/s Cited in Search Report		Patent Family Member/s	
Publication Number	Publication Date	Publication Number	Publication Date
GB 1286010 A	16 Aug 1972	GB 1286010 A	16 Aug 1972
WO 1998/016744 A1	23 Apr 1998	AU 737416 B2	16 Aug 2001
		AU 4543397 A	11 May 1998
		AU 4543497 A	11 May 1998
		BR 9711897 A	18 Jan 2000
		CA 2266633 A1	23 Apr 1998
		EP 0931221 A1	28 Jul 1999
		EP 0931221 B1	14 Jul 2004
		JP 2001506338 A	15 May 2001
		KR 20000049070 A	25 Jul 2000
		US 6280169 B1	28 Aug 2001
		US 2001046448 A1	29 Nov 2001
		US 6468061 B2	22 Oct 2002
		WO 9816743 A1	23 Apr 1998
		WO 9816744 A1	23 Apr 1998
US 3134335 A	26 May 1964	US 3134335 A	26 May 1964
US 1269937 A	18 Jun 1918	US 1269937 A	18 Jun 1918
WO 2011/088596 A1	28 Jul 2011	CN 102135033 A	27 Jul 2011
		GB 2490456 A	31 Oct 2012
		WO 2011088596 A1	28 Jul 2011

End of Annex

Due to data integration issues this family listing may not include 10 digit Australian applications filed since May 2001.

Form PCT/ISA/210 (Family Annex)(July 2009)