



- (51) International Patent Classification:
H04L 27/26 (2006.01)
- (21) International Application Number:
PCT/EP2013/051239
- (22) International Filing Date:
23 January 2013 (23.01.2013)
- (25) Filing Language:
English
- (26) Publication Language:
English
- (71) Applicant (for all designated States except US): HUAWEI TECHNOLOGIES CO., LTD. [CN/CN]; Huawei Administration Building, Bantian Longgang, Shenzhen, Guangdong 518129 (CN).
- (72) Inventor; and
(71) Applicant (for US only): XIE, Changsong [DE/DE]; c/o Huawei Technologies Duesseldorf GmbH, Riesstr. 25, 80992 Munich (DE).
- (74) Agent: KREUZ, Georg M.; c/o Huawei Duesseldorf GmbH, Dessauerstr. 3, 80992 Munich (DE).
- (81) Designated States (unless otherwise indicated, for every kind of national protection available): AE, AG, AL, AM,

AO, AT, AU, AZ, BA, BB, BG, BH, BN, BR, BW, BY, BZ, CA, CH, CL, CN, CO, CR, CU, CZ, DE, DK, DM, DO, DZ, EC, EE, EG, ES, FI, GB, GD, GE, GH, GM, GT, HN, HR, HU, ID, IL, IN, IS, JP, KE, KG, KM, KN, KP, KR, KZ, LA, LC, LK, LR, LS, LT, LU, LY, MA, MD, ME, MG, MK, MN, MW, MX, MY, MZ, NA, NG, NI, NO, NZ, OM, PA, PE, PG, PH, PL, PT, QA, RO, RS, RU, RW, SC, SD, SE, SG, SK, SL, SM, ST, SV, SY, TH, TJ, TM, TN, TR, TT, TZ, UA, UG, US, UZ, VC, VN, ZA, ZM, ZW.

- (84) Designated States (unless otherwise indicated, for every kind of regional protection available): ARIPO (BW, GH, GM, KE, LR, LS, MW, MZ, NA, RW, SD, SL, SZ, TZ, UG, ZM, ZW), Eurasian (AM, AZ, BY, KG, KZ, RU, TJ, TM), European (AL, AT, BE, BG, CH, CY, CZ, DE, DK, EE, ES, FI, FR, GB, GR, HR, HU, IE, IS, IT, LT, LU, LV, MC, MK, MT, NL, NO, PL, PT, RO, RS, SE, SI, SK, SM, TR), OAPI (BF, BJ, CF, CG, CI, CM, GA, GN, GQ, GW, ML, MR, NE, SN, TD, TG).

Published:
— with international search report (Art. 21(3))

(54) Title: COHERENT OPTICAL TRANSMITTER AND COHERENT OPTICAL RECEIVER

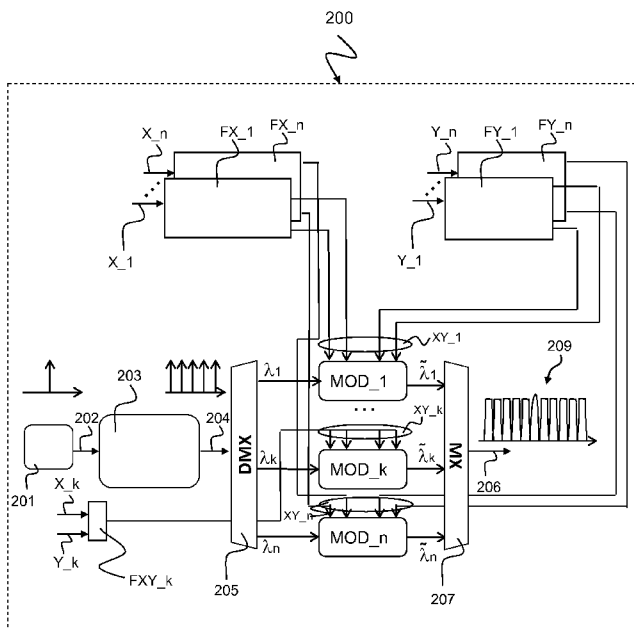

Fig. 2

(57) Abstract: The invention relates to a coherent optical transmitter (200), comprising: a plurality of filters configured for filtering a plurality of data signals, the plurality of filters providing a plurality of filtered data signals, wherein one of the filters is configured for filtering according to a first filtering scheme, and wherein the other ones of the filters are configured for filtering according to a second filtering scheme; a plurality of modulators configured for modulating the plurality of filtered data signals onto a plurality of optical subcarriers ($\lambda_1, \dots, \lambda_k, \dots, \lambda_n$), the plurality of modulators providing a plurality of modulated optical subcarriers ($\tilde{\lambda}_1, \dots, \tilde{\lambda}_k, \dots, \tilde{\lambda}_n$); and a multiplexer (207) configured for multiplexing the plurality of modulated optical subcarriers ($\tilde{\lambda}_1, \dots, \tilde{\lambda}_k, \dots, \tilde{\lambda}_n$) to a super-channel optical signal (206). The invention further relates to a coherent optical receiver (300), comprising: a plurality of coherent optical front ends configured for partitioning a super-channel optical signal (306) into a plurality of sub-channel optical signals, the plurality of coherent optical front ends being driven by a plurality of optical subcarriers ($\lambda_1, \dots, \lambda_k, \dots, \lambda_n$); and a processing circuit (303) coupled to the plurality of coherent optical front ends, the processing circuit (303) being configured to adjust the plurality of coherent optical front ends based on timing information (317) of a predetermined one of the plurality of sub-channel optical signals.

WO 2014/114332 A1

DESCRIPTION**Coherent optical transmitter and coherent optical receiver**5 BACKGROUND

The present invention relates to a coherent optical transmitter and a coherent optical receiver. The invention further relates to a method for providing a super-channel optical signal and to a method for receiving a super-channel optical signal.

10

In optical transmission systems beyond 100Gbps, e.g. 400Gbps or 1Tbps systems also called 400G or 1T systems, multi-subcarrier super-channel systems have to be used due to the bandwidth limitation of electro-optical components. In order to further improve the spectral efficiency in comparison to the 100G single carrier system, OFDM (orthogonal frequency division multiplex) and Nyquist-WDM (Nyquist wavelength division multiplex) schemes are described in US patent 2010/0329683 "System, method and apparatus for coherent optical OFDM" and US patent 2008/0019703 "Optical transmitter using Nyquist pulse shaping". Further publications show the possibility of these two schemes to be candidates for 400G/1T systems. The trials and tests until now relate all to offline processing of one sub-carrier. The technical maturity is still far from commercialization. In order to enable these techniques for industrial application, there are some obstacles which have to be overcome. For example, timing recovery, frequency offset compensation and chromatic dispersion estimation and compensation, are some of such obstacles. eOFDM (electrical OFDM) signals have very weak timing tone. Because in an OFDM signal the sub-tones are frequency-overlapped, in time domain this results in an analog pseudo-random signal for which the timing information of the symbol in sub-carriers has disappeared. Pilot tones or preambles are proposed in US patent 2008/0205905 "Method for estimating time and frequency offset in a OFDM system" and in US patent 2009/0324223 "System, method and apparatus for channel estimation with a dual polarization training symbols for coherent optical OFDM" for insertion into the OFDM symbol stream to enable timing recovery. Nyquist-WDM signals also have weak timing tone, since the time domain inter-symbol interferences among the symbols in the same sub-channel destroy the symbol timing information. Both, eOFDM and Nyquist-WDM systems are very sensitive to frequency offset between Tx (transmit) carrier and Rx (receive) carrier.

35

Currently no product of multi-subcarrier super-channel is available. Applying the methods of chromatic dispersion, timing error estimation and frequency offset estimation used in single carrier system in dense packed multi-subcarrier system with some guard-band between the subcarriers or inserting training sequence or pilot tones into the data results in the following disadvantages. Firstly, the quality and stability of such methods used in dense packed system are much weaker than that used in normal systems such that they may fail in real application scenario and secondly, guard band, training sequence or pilot tones will reduce the spectral efficiency.

10 SUMMARY

It is the object to provide a concept for a multi-subcarrier super-channel technique in a coherent optical communication system that is suitable for high quality and stability and provides high spectral efficiency.

15

This object is achieved by the features of the independent claims. Further implementation forms are apparent from the dependent claims, the description and the figures.

The invention is based on the finding that instead of using the same Tx-DSP architecture for every subcarrier in the traditional super-channel eOFDM and Nyquist-WDM systems, one of the subcarriers is used for conventional modulation, e.g. (D)QPSK modulation. In the eOFDM system this subcarrier does not use frequency overlapping; in the Nyquist-WDM system this subcarrier does not use Nyquist filtering. This special subcarrier carries data with or without training sequence/pilot tone/preamble. Thus, this special sub-channel provides more information to acquire or track the timing clock, estimate the chromatic dispersion (CD) and estimate the frequency offset between Tx-laser and Rx-laser (LOFO, local oscillator frequency offset). The timing recovery, CD estimation, LOFO estimation is performed when receiving this special sub-channel and the acquired information is passed to other sub-channels. Other sub-channels use this information directly, e.g. timing frequency offset and LOFO or with little further processing, e.g. CD estimation or timing jitter processing. Applying the invention relaxes the design of multi-subcarrier eOFDM/Nyquist-WDM transponders and makes development of an industrial applicable product feasible.

By assigning such a special sub-carrier in the coherent optical transmission and reception, the performance of the coherent optical system is significantly improved with respect to quality, stability and spectral efficiency as will be presented in the following.

35

In order to describe the invention in detail, the following terms, abbreviations and notations will be used:

- 5 CD: chromatic dispersion,
- Δ CD: CD difference due to adjacent sub-channel wavelength difference,
- PMD: polarization mode dispersion,
- 10 OFDM: orthogonal frequency division multiplex,
- eOFDM: electrical orthogonal frequency division multiplex,
- 15 WDM: wavelength division multiplex,
- DSP: digital signal processing,
- PDM: polarization division multiplexing,
- 20 PDM-I/Q: polarization division multiplexing with inphase/quadrature signals,
- (D)QPSK: (differential) quaternary phase shift keying
quadrature phase shift keying,
- 25 POLMUX-
QPSK: polarization-multiplexed quadrature phase shift keying,
- CDE: chromatic dispersion estimation,
- 30 LOFO: local oscillator frequency offset,
- ADC: analog/digital converter,
- 35 OFE: optical front end,

VCO: voltage controlled oscillator,

PLL: phase locked loop,

5 LO: local oscillator,

I: in-phase,

10 Q: quadrature,

Tx: transmit,

Rx: receive.

15 According to a first aspect, the invention relates to a coherent optical transmitter, comprising:
a plurality of filters configured for filtering a plurality of data signals, the plurality of filters
providing a plurality of filtered data signals, wherein one of the filters is configured for filtering
according to a first filtering scheme, and wherein the other ones of the filters are configured
for filtering according to a second filtering scheme; a plurality of modulators configured for
20 modulating the plurality of filtered data signals onto a plurality of optical subcarriers, the
plurality of modulators providing a plurality of modulated optical subcarriers; and a
multiplexer configured for multiplexing the plurality of modulated optical subcarriers to a
super-channel optical signal.

25 The coherent optical transmitter provides a multi-subcarrier super-channel optical signal of a
high spectral efficiency for which timing information is easy to reconstruct.

In a first possible implementation form of the coherent optical transmitter according to the
first aspect, the first filtering scheme is configured for preserving timing information of the
30 plurality of data signals.

The coherent optical transmitter provides a multi-subcarrier super-channel optical signal for
which timing information is easy to reconstruct. The multi-subcarrier super-channel optical
signal is a stable signal of high quality.

35

In a second possible implementation form of the coherent optical transmitter according to the first aspect as such or according to the first implementation form of the first aspect, the second filtering scheme is configured for bandwidth-limiting the plurality of data signals.

- 5 Thus, the coherent optical transmitter provides high bandwidth efficiency. A large amount of data can be delivered when the bandwidth is limited, e.g. by bandwidth compression.

In a third possible implementation form of the coherent optical transmitter according to the first aspect as such or according to any of the preceding implementation forms of the first aspect, the second filtering scheme may be a Nyquist-WDM scheme or an eOFDM scheme.

10 By using a Nyquist-WDM scheme or an eOFDM scheme, the bandwidth of the super-channel optical signal is reduced.

- 15 In a fourth possible implementation form of the coherent optical transmitter according to the first aspect as such or according to any of the preceding implementation forms of the first aspect, the first modulation scheme may be a QPSK/DQPSK scheme.

The QPSK/DQPSK scheme is easy to implement as conventional single-carrier optical systems implement QPSK/DQPSK modulation schemes.

In a fifth possible implementation form of the coherent optical transmitter according to the first aspect as such or according to any of the preceding implementation forms of the first aspect, the modulators comprise polarization-division multiplex I/Q modulators each one configured for modulating a data signal comprising a complex-valued X-polarization and a complex-valued Y-polarization component.

When using polarization-division multiplex I/Q modulators, the optical signal can be efficiently transported over the optical communication channel.

30

In a sixth possible implementation form of the coherent optical transmitter according to the first aspect as such or according to any of the preceding implementation forms of the first aspect, a data signal filtered by the one of the filters comprises one of the following: user data and training sequence, user data and pilot tone, user data and preamble, only user data, only training sequence.

35

When the data signal carries a training sequence, a pilot tone or a preamble, timing information is easy to extract. However, timing information can also be extracted when only user data or only training sequence is transmitted.

5 According to a second aspect, the invention relates to a coherent optical receiver, comprising: a plurality of coherent optical front ends configured for partitioning a super-channel optical signal into a plurality of sub-channel optical signals, the plurality of coherent optical front ends being driven by a plurality of optical subcarriers; and a processing circuit coupled to the plurality of coherent optical front ends, the processing circuit being configured
10 to adjust the plurality of coherent optical front ends based on timing information of a predetermined one of the plurality of sub-channel optical signals.

The coherent optical receiver receives a multi-subcarrier super-channel optical signal for which timing information is easy to reconstruct. The multi-subcarrier super-channel optical
15 signal is a stable signal of high quality.

In a first possible implementation form of the coherent optical receiver according to the second aspect, the predetermined one of the plurality of sub-channel optical signals carries a DQPSK-modulated data signal.
20

The DQPSK scheme is easy to implement as conventional single-carrier optical systems implement DQPSK modulation schemes.

In a second possible implementation form of the coherent optical receiver according to the second aspect as such or according to the first implementation form of the second aspect, the other ones of the plurality of sub-channel optical signals carry Nyquist-WDM or eOFDM-modulated data signals.
25

By using a Nyquist-WDM scheme or an eOFDM scheme, the bandwidth of the super-channel optical signal is reduced.
30

In a third possible implementation form of the coherent optical receiver according to the second aspect as such or according to any of the preceding implementation forms of the second aspect, the coherent optical front ends comprise: polarization-diversity optical hybrids
35 configured for providing the plurality of sub-channel optical signals as analog data signals each one of the analog data signals comprising a complex-valued X-polarization and a

complex-valued Y-polarization component; and analog-digital converters configured for converting the analog data signals into digital data signals.

5 When using polarization-diversity optical hybrids data can be efficiently transported over optical networks.

In a fourth possible implementation form of the coherent optical receiver according to the third implementation form of the second aspect, the processing circuit is configured to adjust the digital data signals based on chromatic dispersion information and local oscillator
10 frequency offset information derived from the predetermined one of the plurality of sub-channel optical signals.

The predetermined one of the plurality of sub-channel optical signals provides easy accessible timing information. Therefore, chromatic dispersion information and local oscillator
15 frequency offset information can be easily derived from the predetermined sub-channel optical signal. No bandwidth compression technique has been applied to the predetermined sub-channel and no information has been destroyed.

In a fifth possible implementation form of the coherent optical receiver according to the
20 second aspect as such or according to any of the preceding implementation forms of the second aspect, the coherent optical receiver comprises a multi-subcarrier generator configured for generating the plurality of optical subcarriers based on a single carrier optical signal, wherein the processing circuit is configured to adjust a frequency of the single carrier optical signal based on local oscillator frequency offset information of the predetermined one
25 of the plurality of sub-channel optical signals.

As the comb-generator is configured to lock the frequency of the subcarriers, the LOFOs of all subcarriers are equal. Determination of the LOFO of the predetermined subchannel can be used as LOFO for all other sub-channels.

30

According to a third aspect, the invention relates to a method for providing a super-channel optical signal, the method comprising: filtering a plurality of data signals obtaining a plurality of filtered data signals, wherein the filtering of one of the data signals is according to a first filtering scheme, and wherein the filtering of the other ones of the data signals is according to
35 a second filtering scheme; modulating the plurality of filtered data signals onto a plurality of

optical subcarriers obtaining a plurality of modulated optical subcarriers; and multiplexing the plurality of modulated optical subcarriers obtaining the super-channel optical signal.

5 The method for providing a super-channel optical signal provides a signal of a high spectral efficiency for which timing information is easy to reconstruct.

10 According to a fourth aspect, the invention relates to a method for receiving a super-channel optical signal, the method comprising: partitioning the super-channel optical signal into a plurality of sub-channel optical signals by using a plurality of optical subcarriers; and adjusting the partitioning based on timing information of a predetermined one of the plurality of sub-channel optical signals.

15 The method is configured for receiving a super-channel optical signal for which signal timing information is easy to reconstruct. The multi-subcarrier super-channel optical signal is a stable signal of high quality.

20 The methods and devices described here are applicable in particular for long-haul transmission using 100-Gb/s polarization-multiplexed quadrature phase shift keying (POLMUX-QPSK) modulation, which is widely applied in products for long-haul optical transmission systems. POLMUX-QPSK modulation is often also referred to as CP-QPSK, PDM-QPSK, 2P-QPSK or DP-QPSK. Similarly, the method applies for other digital modulation formats being single polarization modulation, binary phase shift keying (BPSK) or higher-order quadrature amplitude modulation (QAM).

25 The methods described herein may be implemented as software in a Digital Signal Processor (DSP), in a micro-controller or in any other side-processor or as hardware circuit within an application specific integrated circuit (ASIC).

30 The invention can be implemented in digital electronic circuitry, or in computer hardware, firmware, software, or in combinations thereof.

These and other aspects of the invention will be apparent from the embodiment(s) described below.

35

BRIEF DESCRIPTION OF THE DRAWINGS

Further embodiments of the invention will be described with respect to the following figures, in which:

5 Fig. 1 shows a block diagram of a multi-subcarrier super-channel optical transmission system according to an implementation form;

Fig. 2 shows a block diagram of a coherent optical transmitter according to an implementation form;

10

Fig. 3 shows a block diagram of a coherent optical receiver according to an implementation form;

15 Fig. 4 shows a schematic diagram of a method for providing a super-channel optical signal according to an implementation form; and

Fig. 5 shows a schematic diagram of a method for receiving a super-channel optical signal according to an implementation form.

20

DETAILED DESCRIPTION OF EMBODIMENTS OF THE INVENTION

Fig. 1 shows a block diagram of a multi-subcarrier super-channel optical transmission system 100 according to an implementation form. The multi-subcarrier super-channel optical 25 transmission system transmits and receives multi-subcarrier super-channel optical signals 180 as depicted in the upper part of the figure. Such a multi-subcarrier super-channel optical signal 180 carries a number of modulated optical subcarriers $\tilde{\lambda}_1, \tilde{\lambda}_2, \tilde{\lambda}_3, \dots, \tilde{\lambda}_{n-1}, \tilde{\lambda}_n$, wherein one of the optical subcarriers, in this implementation form the first optical subcarrier λ_1 is modulated according to a first modulation scheme and the other ones of the optical 30 subcarriers, in this implementation form the second to the n-th subcarriers $\lambda_2, \lambda_3, \dots, \lambda_{n-1}, \lambda_n$ are modulated according to a second modulation scheme. The first modulation scheme, e.g. a QPSK modulation or a DQPSK modulation or a polarization-multiplexed quadrature phase shift keying modulation is a modulation scheme which preserves timing information of the data being modulated by that scheme. The second modulation scheme, e.g. a filtering 35 according to an electrical OFDM scheme or according to a Nyquist-WDM scheme is a scheme which provides bandwidth-efficient data transmission, i.e. a lot of data is packed into

the subcarriers $\lambda_2, \lambda_3, \dots, \lambda_{n-1}, \lambda_n$ by using spectral overlapping or bandwidth compression methods. In an implementation form, the subcarriers $\lambda_2, \lambda_3, \dots, \lambda_{n-1}, \lambda_n$ implementing the second modulation scheme are designed according to the methods described in US patent 2010/0329683 "System, method and apparatus for coherent optical OFDM" or in US patent 2008/0019703 "Optical transmitter using Nyquist pulse shaping". In an implementation form, the first optical subcarrier λ_1 implementing the first modulation scheme is designed according to a conventional single carrier optical modulation system, e.g. by using a QPSK or a DQPSK modulation or PDM-(D)QPSK or PDM-xQAM modulation.

When receiving such a multi-subcarrier super-channel optical signal 180 by an optical receiver, three signal processing circuits 111, 121, 131 at receiver side are used for signal processing. A CD estimation circuit 111 is used for estimation of chromatic dispersion (CD); a LOFO estimation circuit 121 is used for estimation of local oscillator frequency offset and a timing error (ΔT) estimation circuit 131 is used for estimation of the timing error ΔT . All three circuits 111, 121, 131 perform their estimation based on information derived from the special or predetermined optical subcarrier, in this implementation form from the first optical subcarrier λ_1 .

In a system according to an implementation form where another one of the optical subcarriers is used as the special or predetermined subcarrier λ_k , the CD compensation follows the relation $CD(n) = CD(k) + S(\lambda_n - \lambda_k)$ where S describes the CD slope.

The estimated chromatic dispersion CD estimated by the CD estimation circuit 111 is used for compensating chromatic dispersion of the received multi-subcarrier super-channel optical signal 180, wherein the second optical subcarrier λ_2 is compensated by $CD + \Delta CD$, the third optical subcarrier λ_3 is compensated by the estimated chromatic dispersion CD plus two times the CD difference (ΔCD) due to adjacent sub-channel wavelength difference, the (n-1)-th optical subcarrier λ_{n-1} is compensated by the estimated chromatic dispersion CD plus (n-2) times the CD difference (ΔCD) and the n-th optical subcarrier λ_n is compensated by the estimated chromatic dispersion CD plus (n-1) times the CD difference (ΔCD). As the multi-subcarrier system uses a comb-generator for generating the multi-subcarrier super-channel optical signal 180, frequency offsets of the subcarriers are locked. Further, all subcarriers have the same sampling rate and can share the timing clock. Therefore, CD compensation according to the above-mentioned scheme provides accurate compensation.

The estimated local oscillator frequency offset (LOFO) estimated by the LOFO estimation circuit 121 is used for adjusting a frequency tuner 122 providing a frequency offset to a laser 123 for generating the multi-subcarrier optical signal comprising the first to the n-th subcarriers $\lambda_1, \lambda_2, \lambda_3, \dots, \lambda_{n-1}, \lambda_n$.

5

The estimated timing error ΔT estimated by the timing error estimation circuit 131 is used for adjusting a phase-locked loop (PLL) 132 which controls a voltage controlled oscillator (VCO) 133 providing a clock signal 134 to a plurality of analog-digital converters (ADCs) 141, 142, 143, 144 for sampling the received multi-subcarrier super-channel optical signal 180.

10

A multi-subcarrier super-channel optical transmission system 100 as depicted in Fig. 1 provides the following benefits. The special sub-channel can contain data, e.g. less data capacity as other bandwidth compressed sub-channels with training sequence or only data without training sequence. From this special sub-channel, the digital signal processing (DSP) gets the timing error estimation, the CD estimation and the local frequency offset estimation. Such information will be delivered to DSPs of other channels for digital compensation. Timing error and LOFO will also be delivered to the control loop for VCO tuning and LO frequency tuning. Operability is guaranteed due to the following reasons. As the multi-subcarrier system uses a comb-generator 124, the frequency of the subcarriers are locked, consequently the LOFOs of all subcarriers are identical. As all subcarriers have the same sampling rate, they can share the timing clock. The only difference is the timing phase, but a sampling of two samples per symbol does not depend on the sampling phase. CD values of other subcarriers can be derived by $CD(n) = CD(k) + S^*(\lambda_n - \lambda_k)$. n and k denote respective indices of subcarriers, CD(n) and CD(k) denote chromatic dispersion of the respective sub-carriers, S denotes a number of samples per symbol and λ_n and λ_k denote the respective sub-carriers with the indices n and k.

25

Therefore, this multi-subcarrier super-channel optical transmission system 100 improves the performance of the overall super-channel transmission. Further, it saves the DSP complexity and Rx hardware complexity as the above functions are executed only in this special sub-channel. Other sub-channels can be designed for saving these modules or for simplifying these modules dramatically.

30

Fig. 2 shows a block diagram of a coherent optical transmitter according to an implementation form.

35

The transmitter 200 comprises multiple filters $FX_1, FY_1, \dots, FXY_k, \dots, FX_n, FY_n$ for filtering multiple data signals $X_1, Y_1, \dots, X_k, Y_k, \dots, X_n, Y_n$ providing multiple filtered data signals $XY_1, \dots, XY_k, \dots, XY_n$. A first filter FX_1, FY_1 is used for filtering a first data signal X_1, Y_1 . A k-th filter FXY_k is used for filtering a k-th data signal X_k, Y_k . An n-th filter FX_n, FY_n is used for filtering an n-th data signal X_n, Y_n . k and n are any integer numbers. Each of the multiple data signals $X_1, Y_1, \dots, X_k, Y_k, \dots, X_n, Y_n$ comprises a complex-valued X-polarization $X_i, i=1, \dots, k, \dots, n$ and a complex-valued Y-polarization $Y_i, i=1, \dots, k, \dots, n$ component. The X-polarization components are filtered by X-polarization parts $FX_i, i=1, \dots, k, \dots, n$ of the filters and the Y-polarization components are filtered by Y-polarization parts $FY_i, i=1, \dots, k, \dots, n$ of the filters. For the index k only one filter FXY_k is depicted in Fig. 2. This filter FXY_k , however, similarly comprises an X-polarization part and a Y-polarization part as the filters FX_1, FY_1 and FX_n, FY_n . The outputs of the filters, i.e. the filtered data signals $XY_1, \dots, XY_k, \dots, XY_n$ are complex-valued comprising an in-phase and a quadrature part for each polarization resulting in a number of four outputs per filter.

The transmitter 200 further comprises multiple modulators $MOD_1, \dots, MOD_k, \dots, MOD_n$ for modulating the multiple filtered data signals $XY_1, \dots, XY_k, \dots, XY_n$ onto multiple optical subcarriers $\lambda_1, \dots, \lambda_k, \dots, \lambda_n$ providing multiple modulated optical subcarriers $\tilde{\lambda}_1, \dots, \tilde{\lambda}_k, \dots, \tilde{\lambda}_n$. A first modulator MOD_1 modulates the first filtered data signal XY_1 onto the first optical subcarrier λ_1 providing the first modulated optical subcarrier $\tilde{\lambda}_1$. A k-th modulator MOD_k modulates the k-th filtered data signal XY_k onto the k-th optical subcarrier λ_k providing the k-th modulated optical subcarrier $\tilde{\lambda}_k$ and the n-th modulator MOD_n modulates the n-th filtered data signal XY_n onto the n-th optical subcarrier λ_n providing the n-th modulated optical subcarrier $\tilde{\lambda}_n$. n and k can be any integer number.

The transmitter 200 further comprises a multiplexer 207 for multiplexing the multiple modulated optical subcarriers $\tilde{\lambda}_1, \dots, \tilde{\lambda}_k, \dots, \tilde{\lambda}_n$ to a super-channel optical signal 206. As can be seen from the spectrum 209 of the super-channel optical signal 206 depicted in Fig. 2, one of the sub-channel, here the k-th sub-channel, has a different shape than the other sub-channels. This results from different filtering for this special sub-channel. One of the filters, denoted as the k-th filter FXY_k is configured for filtering according to a first filtering scheme and the other filters $FX_1, FY_1, \dots, FX_n, FY_n$ are configured for filtering according to a second filtering scheme which is different from the first filtering scheme. Therefore, a different spectrum 209 in the super-channel optical signal 206 can be observed. The special sub-channel k can be any of the sub-channels.

The first filtering scheme filtering the k-th sub-channel is configured for preserving timing information of the data signals for allowing a receiver reconstructing the timing behavior of the data signal. The second filtering scheme filtering all other sub-channels is configured for bandwidth-limiting the data signals allowing to transmit large amounts of data. That is, one sub-channel may be used for preserving the timing information while the other sub-channels may be used for exploiting the full bandwidth of the transmission medium.

In an implementation form, the second filtering scheme may be a Nyquist-WDM scheme or an eOFDM scheme. In an implementation form, the first filtering scheme may be a QPSK or a DQPSK scheme. In an implementation form, the first filtering scheme may be a conventional filtering scheme used for optical single-carrier transmission.

In an implementation form, the multiple modulators MOD₁, ..., MOD_k, ..., MOD_n comprise polarization-division multiplex I/Q modulators each one configured for modulating a data signal XY_i, i=1,...,k,...,n comprising a complex-valued X-polarization component X_i, i=1,...,k,...,n and a complex-valued Y-polarization component Y_i, i=1,...,k,...,n. k and n are any integer numbers.

In an implementation form shown in Fig. 2, the multiple optical subcarriers $\lambda_1, \dots, \lambda_k, \dots, \lambda_n$ are generated by a multi-subcarrier generator 203, e.g. an optical comb filter. The multi-subcarrier generator 203 is driven by a laser 201 generating a single carrier optical signal 202 which is used by the multi-subcarrier generator 203 to generate a multi-carrier optical signal 204. The multi-carrier optical signal 204 is demultiplexed by a demultiplexer "DMX" 205 into the multiple optical subcarriers $\lambda_1, \dots, \lambda_k, \dots, \lambda_n$ which are provided to the multiple modulators MOD₁, ..., MOD_k, ..., MOD_n.

In an implementation form, the k-th data signal X_k, Y_k filtered by the special k-th filter by applying the first filtering scheme comprises both, user data and a training sequence. In an implementation form, the k-th data signal X_k, Y_k filtered by the special k-th filter by applying the first filtering scheme comprises both, user data and a pilot tone. In an implementation form, the k-th data signal X_k, Y_k filtered by the special k-th filter by applying the first filtering scheme comprises both, user data and a preamble. In an alternative implementation form, the k-th data signal X_k, Y_k filtered by the special k-th filter by applying the first filtering scheme comprises only user data or only a training sequence or only a pilot tone or only a preamble.

Among the sub-channels depicted in Fig. 2, λ_k is the subcarrier which carries normally modulated signal, with normal pulse shaping, e.g. a conventional modulated signal using a single-carrier optical system. λ_k can be anyone of the sub-channels in the super-channel.

- 5 The other sub-channels are spectrum compressed either using OFDM in one implementation form or using Nyquist filtering in another implementation form or any other bandwidth compressed form in yet another implementation form.

10 The transmitter 200 depicted in Fig. 2 can be used for providing the super-channel optical signal 180 depicted in Fig. 1.

Fig. 3 shows a block diagram of a coherent optical receiver 300 according to an implementation form. The receiver 300 comprises multiple coherent optical front ends 301_1, ..., 301_k, ..., 301_n for partitioning a super-channel optical signal 306 into multiple sub-channel optical signals XY_1, ..., XY_k, ..., XY_n. Each of the multi-channel optical signals XY_1, ..., XY_k, ..., XY_n comprises an in-phase part and a quadrature part of an X-polarization component and an in-phase part and a quadrature part of a Y-polarization component. The multiple coherent optical front ends 301_1, ..., 301_k, ..., 301_n are driven by multiple optical subcarriers $\lambda_1, \dots, \lambda_k, \dots, \lambda_n$. A first coherent optical front end 301_1 partitions the super-channel optical signal 306 into a first sub-channel optical signal XY_1. A k-th coherent optical front end 301_k partitions the super-channel optical signal 306 into a k-th sub-channel optical signal XY_k. An n-th coherent optical front end 301_n partitions the super-channel optical signal 306 into an n-th sub-channel optical signal XY_n. k and n are any integer numbers.

25

The first coherent optical front end 301_1 is driven by a first optical sub-carrier λ_1 . The k-th coherent optical front end 301_k is driven by a k-th optical sub-carrier λ_k . The n-th coherent optical front end 301_n is driven by an n-th optical sub-carrier λ_n . k and n are any integer numbers.

30

The receiver 300 further comprises a processing circuit 303 coupled to the multiple coherent optical front ends 301_1, ..., 301_k, ..., 301_n. The processing circuit 303 is configured to adjust the plurality of coherent optical front ends 301_1, ..., 301_k, ..., 301_n based on timing information 317 of a predetermined one, here the k-th, of the multiple sub-channel optical signals XY_1, ..., XY_k, ..., XY_n. The processing circuit 303 comprises multiple DSPs 311_1, 311_k, 311_n. Each of the DSPs is coupled to a respective one of the coherent

35

optical front ends 301_1, 301_k, 301_n. A first DSP 311_1 is coupled to the first coherent optical front end 301_1 for receiving the first sub-channel optical signals XY_1. The k-th DSP 311_k is coupled to the k-th coherent optical front end 301_k for receiving the k-th sub-channel optical signal XY_k. The n-th DSP 311_n is coupled to the n-th coherent optical front end 301_n for receiving the n-th sub-channel optical signal XY_n.

As can be seen from the spectrum 309 of the super-channel optical signal 306 depicted in Fig. 3, one of the sub-channels, here the k-th sub-channel, has a different shape than the other sub-channels. This different structure is resulting from different filtering for this special sub-channel, e.g. filtering in the transmitter 200 described above with respect to Fig. 2. The special sub-channel is located at a predetermined position, here denoted by the index k, in the spectrum 309 of the super-channel optical signal 306. One of the DSPs, denoted as the k-th DSP 311_k is configured for filtering the k-th (i.e. the predetermined) sub-channel optical signal according to a first filtering scheme. The other DSPs 311_1, ..., 311_n are configured for filtering according to a second filtering scheme which is different from the first filtering scheme. Therefore, a different spectrum 309 in the super-channel optical signal 306 can be processed by the DSPs of the processing circuit 303. The special sub-channel k can be any of the sub-channels.

The first filtering scheme used for processing the k-th sub-channel is configured for preserving timing information of the data signals for allowing the receiver 300 reconstructing the timing behavior of the data signal. The second filtering scheme filtering all other sub-channels is configured for bandwidth-limiting the data signals allowing to transmit large amounts of data. That is, one sub-channel is used for preserving the timing information while the other sub-channels are used for exploiting the full bandwidth of the transmission medium.

In an implementation form, the second filtering scheme may be a Nyquist-WDM scheme or an eOFDM scheme. In an implementation form, the first filtering scheme may be a QPSK or a DQPSK scheme. In an implementation form, the first filtering scheme may be a conventional filtering scheme used for optical single-carrier transmission.

The k-th DSP 311_k comprises a local oscillator frequency offset (LOFO) estimation circuit 313 which is used for estimating the local oscillator frequency offset. The estimated LOFO is used for compensating the frequency offset of the k-th sub-channel optical signal XY_k. The estimated LOFO is provided by the k-th DSP 311_k to the other DSPs 311_1, ..., 311_n for

compensating the frequency offsets of the other sub-channel optical signals XY_1, \dots, XY_n by that same LOFO estimated by the k-th DSP 311_k.

5 The k-th DSP 311_k comprises a chromatic dispersion (CD) estimation circuit 315 which is used for estimating the chromatic dispersion. The estimated CD is used for compensating the chromatic dispersion of the k-th sub-channel optical signal XY_k . The estimated CD is provided by the k-th DSP 311_k to the other DSPs 311_1, ..., 311_n for compensating the chromatic dispersion of the other sub-channel optical signals XY_1, \dots, XY_n by that same CD estimated by the k-th DSP 311_k.

10

The k-th DSP 311_k further comprises a timing (ΔT) estimation circuit 317 which is used for estimating a timing error based on the k-th sub-channel optical signal XY_k . The estimated timing error is provided to a phase locked loop (PLL) 325 which is used for adjusting a voltage controlled oscillator (VCO) 313 for compensating the timing error of the k-th sub-channel optical signal XY_k and of the other sub-channel optical signals XY_1, \dots, XY_n based on that same timing error processed by the k-th DSP 311_k.

15

Each of the multiple coherent optical front ends 301_1, ..., 301_k, ..., 301_n comprises a polarization-diversity optical hybrid 307_1, ..., 307_k, ..., 307_n for providing the multiple sub-channel optical signals $XY_1, \dots, XY_k, \dots, XY_n$ as analog data signals. Each of the analog data signals comprises a complex-valued X-polarization and a complex-valued Y-polarization component. Each of the multiple coherent optical front ends 301_1, ..., 301_k, ..., 301_n further comprises an analog-digital converter 309_1, ..., 309_k, ..., 309_n for converting the analog data signals into digital data signals. The VCO 313 is used for providing a correct time base for the multiple analog-digital converters 309_1, ..., 309_k, ..., 309_n.

20

25

The processing circuit 303 therefore adjusts the digital data signals based on chromatic dispersion information and local oscillator frequency offset information derived from the predetermined sub-channel optical signal XY_k .

30

In an implementation form shown in Fig. 3, the multiple optical subcarriers $\lambda_1, \dots, \lambda_k, \dots, \lambda_n$ are generated by a multi-subcarrier generator 323, e.g. an optical comb filter. The multi-subcarrier generator 323 is driven by a laser 321 generating a single carrier optical signal 302 which is used by the multi-subcarrier generator 323 to generate a multi-carrier optical signal 304. The multi-carrier optical signal 304 is demultiplexed by a demultiplexer 305 into

35

the multiple optical subcarriers $\lambda_1, \dots, \lambda_k, \dots, \lambda_n$ which are provided to the multiple coherent optical front ends 301_1, ..., 301_k, ..., 301_n. A frequency tuner 319 is used to adjust the carrier width of the laser 321 based on the estimated LOFO of the LOFO estimation circuit 313 derived from the predetermined sub-channel optical signal XY_k.

5

The LOFO estimation circuit described with respect to Fig. 3 may correspond to the LOFO estimation as described with respect to Fig. 1, in particular the LOFO estimation circuit 313 may correspond to the respective unit 121, the frequency tuner 319 may correspond to the respective unit 122, the laser 321 may correspond to the laser 123 and the multi-subcarrier generator 323 may correspond to the multi-subcarrier generator 124.

10

The CD estimation circuit described with respect to Fig. 3 may correspond to the CD estimation as described with respect to Fig. 1, in particular the DSPs 311_1, ..., 311_k, ..., 311_n may be used for implementing the CD compensation units 112, 113, 114, 115.

15

The timing estimation circuit described with respect to Fig. 3 may correspond to the timing estimation as described with respect to Fig. 1, in particular the timing estimation circuit 317 may correspond to the respective unit 131, the PLL 325 may correspond to the PLL 132, the VCO 313 may correspond to the VCO 133 and the clock signal provided by the VCO 313 to the ADCs 309_1, ..., 309_k, ..., 309_n may correspond to clock signal 134 provided to the ADCs 141, 142, 143, 144.

20

In an implementation form, the receiver 300 implements the receiving method as described with respect to Fig. 1. In an implementation form, the receiver 300 is used for receiving the super-channel optical signal 180 depicted in Fig. 1 or for receiving the super-channel optical signal 206 depicted in Fig. 2.

25

In an implementation form, λ_k is the subcarrier which carries a normally modulated signal without spectrum compression, e.g. a modulated signal of a single-carrier optical system.

30

Digital signal processing for this sub-channel contains the modules for local frequency offset (LOFO) estimation 313, chromatic dispersion (CD) estimation 315 and timing error estimation 317. CD and LOFO values pass to the DSPs 311_1, ..., 311_k, ..., 311_n of the other sub-channels for digital compensation. The LOFO values are also delivered to local oscillator (LO) frequency tuner 319. The Timing error values are delivered to the phase locked loop (PLL)

35

325 to control the sampling clock of the analog-to-digital converts (ADCs) 309_1, ..., 309_k, ..., 309_n.

A coherent optical transmission system comprises one or more coherent optical transmitters 200 as described with respect to Fig. 2 and one or more coherent optical receivers 300 as described with respect to Fig. 3.

5

From another perspective, the implementation form of the preceding coherent optical transmitter illustrated in Fig. 3 also provides a method for providing a super-channel optical signal. Fig. 4 shows a schematic diagram of a method for providing a super-channel optical signal according to the preceding coherent optical transmitter illustrated in Fig. 3. The method 400 comprises filtering 401 a plurality of data signals to obtain a plurality of filtered data signals, wherein the filtering of one of the data signals is according to a first filtering scheme and wherein the filtering of the other ones of the data signals is according to a second filtering scheme. The method 400 further comprises modulating 403 the plurality of filtered data signals onto a plurality of optical subcarriers $\lambda_1, \dots, \lambda_k, \dots, \lambda_n$ to obtain a plurality of modulated optical subcarriers $\tilde{\lambda}_1, \dots, \tilde{\lambda}_k, \dots, \tilde{\lambda}_n$. The method 400 further comprises multiplexing 405 the plurality of modulated optical subcarriers $\tilde{\lambda}_1, \dots, \tilde{\lambda}_k, \dots, \tilde{\lambda}_n$ to obtain the super-channel optical signal. The method 400 may further comprise steps as disclosed in the implementation form of the preceding coherent optical transmitter illustrated in Fig. 3.

10

15

20

From another perspective, the implementation form of the preceding coherent optical receiver illustrated in Fig. 2 also provides a method for receiving a super-channel optical signal. Fig. 5 shows a schematic diagram of a method for receiving a super-channel optical signal according to the preceding coherent optical receiver illustrated in Fig. 2. The method 500 comprises partitioning 501 the super-channel optical signal into a plurality of sub-channel optical signals by using a plurality of optical subcarriers $\lambda_1, \dots, \lambda_k, \dots, \lambda_n$. The method 500 further comprises adjusting 503 the partitioning based on timing information of a predetermined one of the plurality of sub-channel optical signals. The method 500 may further comprise steps as disclosed in the implementation form of the preceding coherent optical receiver illustrated in Fig. 2.

25

30

From the foregoing, it will be apparent to those skilled in the art that a variety of methods, systems, computer programs on recording media, and the like, are provided.

The present disclosure also supports a computer program product including computer executable code or computer executable instructions that, when executed, causes at least

35

one computer to execute the providing method and/or the receiving method described herein.

5 The present disclosure also supports a system comprising the preceding coherent optical receiver and the preceding coherent optical transmitter described herein.

10 Many alternatives, modifications, and variations will be apparent to those skilled in the art in light of the above teachings. Of course, those skilled in the art readily recognize that there are numerous applications of the invention beyond those described herein. While the present inventions has been described with reference to one or more particular embodiments, those skilled in the art recognize that many changes may be made thereto without departing from the scope of the present invention. It is therefore to be understood that within the scope of the appended claims and their equivalents, the inventions may be practiced otherwise than as specifically described herein.

CLAIMS:

1. A coherent optical transmitter (200), comprising:

5 a plurality of filters (FX₁, FY₁, ..., FX_k, ..., FX_n, FY_n) configured for filtering a plurality of data signals (X₁, Y₁, ..., X_k, Y_k, ..., X_n, Y_n), to obtain a plurality of filtered data signals (XY₁, ..., XY_k, ..., XY_n), wherein one (FX_k) of the filters (FX₁, FY₁, ..., FX_k, ..., FX_n, FY_n) is configured for filtering according to a first filtering scheme, and wherein the other ones (FX₁, FY₁, ..., FX_n, FY_n) of the filters (FX₁, FY₁, ..., FX_k, ..., FX_n, FY_n) are configured for filtering according to a second filtering scheme;

10 a plurality of modulators (MOD₁, ..., MOD_k, ..., MOD_n) configured for modulating the plurality of filtered data signals (XY₁, ..., XY_k, ..., XY_n) onto a plurality of optical subcarriers (λ_1 , ..., λ_k , ..., λ_n), to obtain a plurality of modulated optical subcarriers ($\tilde{\lambda}_1$, ..., $\tilde{\lambda}_k$, ..., $\tilde{\lambda}_n$); and

15 a multiplexer (207) configured for multiplexing the plurality of modulated optical subcarriers ($\tilde{\lambda}_1$, ..., $\tilde{\lambda}_k$, ..., $\tilde{\lambda}_n$) to a super-channel optical signal (206).
2. The coherent optical transmitter (200) of claim 1, wherein the first filtering scheme is configured for preserving timing information of the plurality of data signals (X₁, Y₁, ..., X_k, Y_k, ..., X_n, Y_n).
3. The coherent optical transmitter (200) of claim 1 or claim 2, wherein the second
20 filtering scheme is configured for bandwidth-limiting the plurality of data signals (X₁, Y₁, ..., X_k, Y_k, ..., X_n, Y_n).
4. The coherent optical transmitter (200) of one of the preceding claims, wherein the second filtering scheme is a Nyquist-WDM scheme or an eOFDM scheme.
5. The coherent optical transmitter (200) of one of the preceding claims, wherein the first
25 filtering scheme is a DQPSK scheme.
6. The coherent optical transmitter (200) of one of the preceding claims, wherein the modulators (MOD₁, ..., MOD_k, ..., MOD_n) comprise polarization-division multiplex I/Q modulators each one configured for modulating a data signal (X₁, Y₁) comprising a complex-valued X-polarization (X₁) and a complex-valued Y-polarization (Y₁) component.

7. The coherent optical transmitter (200) of one of the preceding claims, wherein a data signal (X_k , Y_k) filtered by the one (F_{XY_k}) of the filters (F_{X_1} , F_{Y_1} , ..., F_{XY_k} , ..., F_{X_n} , F_{Y_n}) comprises one of the following:
- user data and training sequence,
 - 5 user data and pilot tone,
 - user data and preamble,
 - only user data,
 - only training sequence.
8. A coherent optical receiver (300), comprising:
- 10 a plurality of coherent optical front ends (301_1 , ..., 301_k , ..., 301_n) configured for partitioning a super-channel optical signal (306) into a plurality of sub-channel optical signals (XY_1 , ..., XY_k , ..., XY_n), the plurality of coherent optical front ends (301_1 , ..., 301_k , ..., 301_n) being driven by a plurality of optical subcarriers (λ_1 , ..., λ_k , ..., λ_n); and
- a processing circuit (303) coupled to the plurality of coherent optical front ends
- 15 (301_1 , ..., 301_k , ..., 301_n), the processing circuit (303) being configured to adjust the plurality of coherent optical front ends (301_1 , ..., 301_k , ..., 301_n) based on timing information (317) of a predetermined one (XY_k) of the plurality of sub-channel optical signals (XY_1 , ..., XY_k , ..., XY_n).
9. The coherent optical receiver (300) of claim 8, wherein the predetermined one (XY_k)
- 20 of the plurality of sub-channel optical signals (XY_1 , ..., XY_k , ..., XY_n) carries a DQPSK-modulated data signal.
10. The coherent optical receiver (300) of claim 8 or claim 9, wherein the other ones (XY_1 , ..., XY_n) of the plurality of sub-channel optical signals (XY_1 , ..., XY_k , ..., XY_n) carry Nyquist-WDM or eOFDM-modulated data signals.
- 25 11. The coherent optical receiver (300) of one of claims 8 to 10, wherein the coherent optical front ends (301_1 , ..., 301_k , ..., 301_n) comprise:
- polarization-diversity optical hybrids (307_1 , ..., 307_k , ..., 307_n) configured for providing the plurality of sub-channel optical signals (XY_1 , ..., XY_k , ..., XY_n) as analog

data signals each one of the analog data signals comprising a complex-valued X-polarization and a complex-valued Y-polarization component; and

analog-digital converters (309_1, ..., 309_k, ..., 309_n) configured for converting the analog data signals into digital data signals.

5 12. The coherent optical receiver (300) of claim 11, wherein the processing circuit (303) is configured to adjust the digital data signals based on chromatic dispersion information (315) and local oscillator frequency offset information (313) derived from the predetermined one (XY_k) of the plurality of sub-channel optical signals (XY_1, ..., XY_k, ..., XY_n).

10 13. The coherent optical receiver (300) of one of claims 8 to 12, comprising a multi-subcarrier generator (323) configured for generating the plurality of optical subcarriers ($\lambda_1, \dots, \lambda_k, \dots, \lambda_n$) based on a single carrier optical signal (302), wherein the processing circuit (303) is configured to adjust a frequency of the single carrier optical signal (302) based on local oscillator frequency offset information (313) of the predetermined one (XY_k) of the plurality of sub-channel optical signals (XY_1, ..., XY_k, ..., XY_n).

15 14. Method (400) for providing a super-channel optical signal, the method (400) comprising:

20 filtering (401) a plurality of data signals obtaining a plurality of filtered data signals, wherein the filtering of one of the data signals is according to a first filtering scheme, and wherein the filtering of the other ones of the data signals is according to a second filtering scheme;

modulating (403) the plurality of filtered data signals onto a plurality of optical subcarriers ($\lambda_1, \dots, \lambda_k, \dots, \lambda_n$) obtaining a plurality of modulated optical subcarriers ($\tilde{\lambda}_1, \dots, \tilde{\lambda}_k, \dots, \tilde{\lambda}_n$); and

25 multiplexing (405) the plurality of modulated optical subcarriers ($\tilde{\lambda}_1, \dots, \tilde{\lambda}_k, \dots, \tilde{\lambda}_n$) obtaining the super-channel optical signal.

15. Method (500) for receiving a super-channel optical signal, the method (500) comprising:

partitioning (501) the super-channel optical signal into a plurality of sub-channel optical signals by using a plurality of optical subcarriers ($\lambda_1, \dots, \lambda_k, \dots, \lambda_n$); and

adjusting (503) the partitioning based on timing information of a predetermined one of the plurality of sub-channel optical signals.

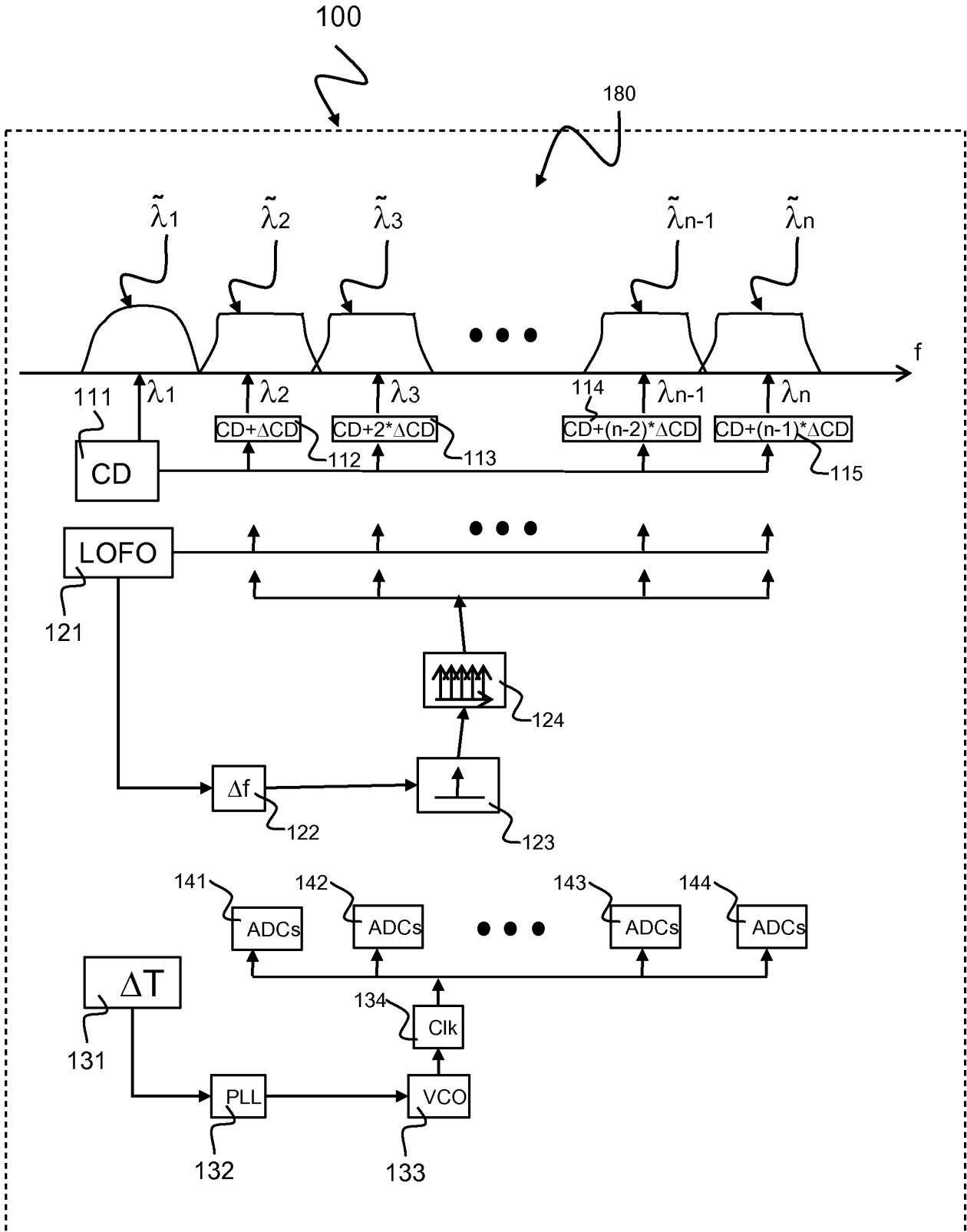

Fig. 1

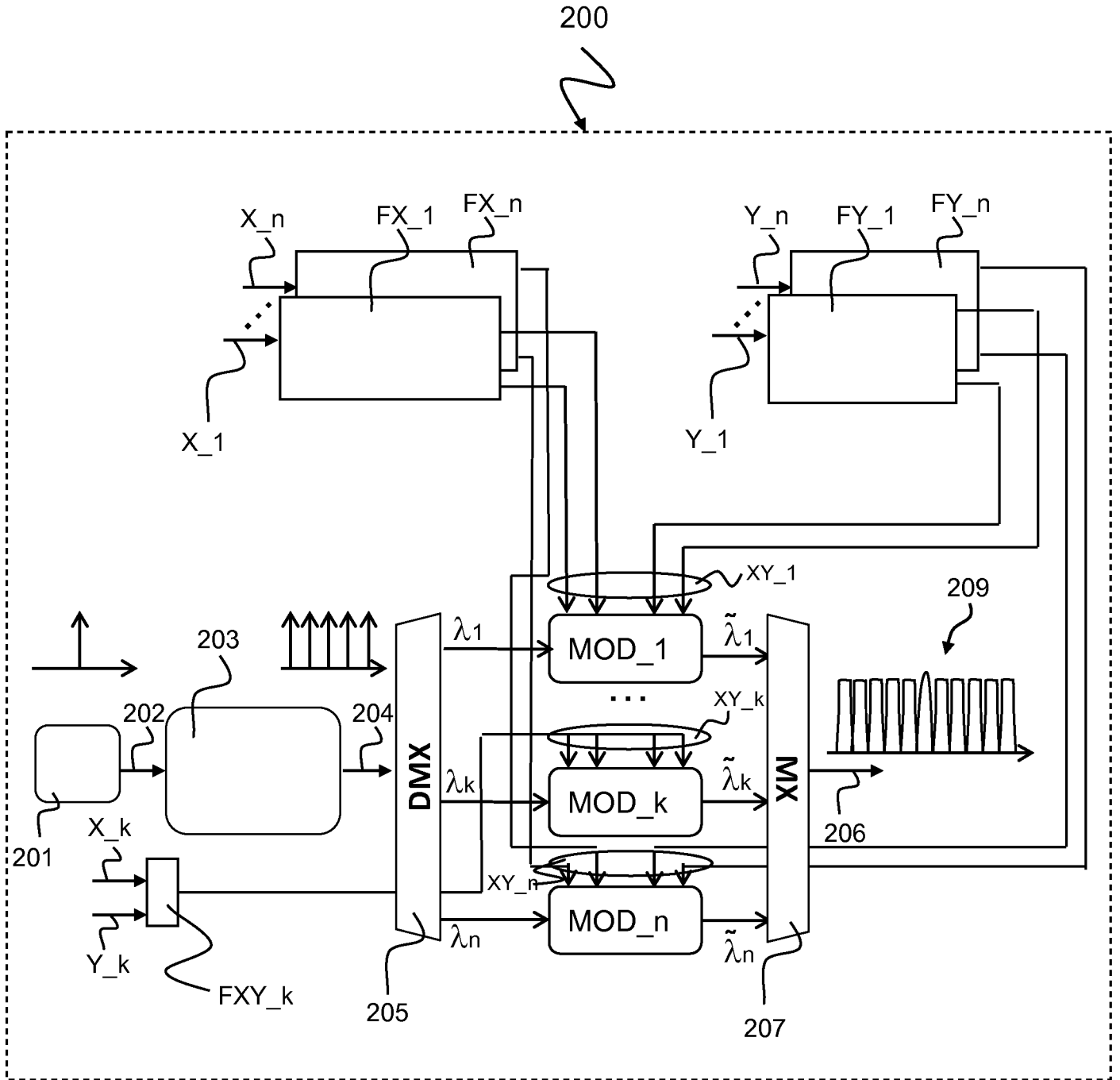

Fig. 2

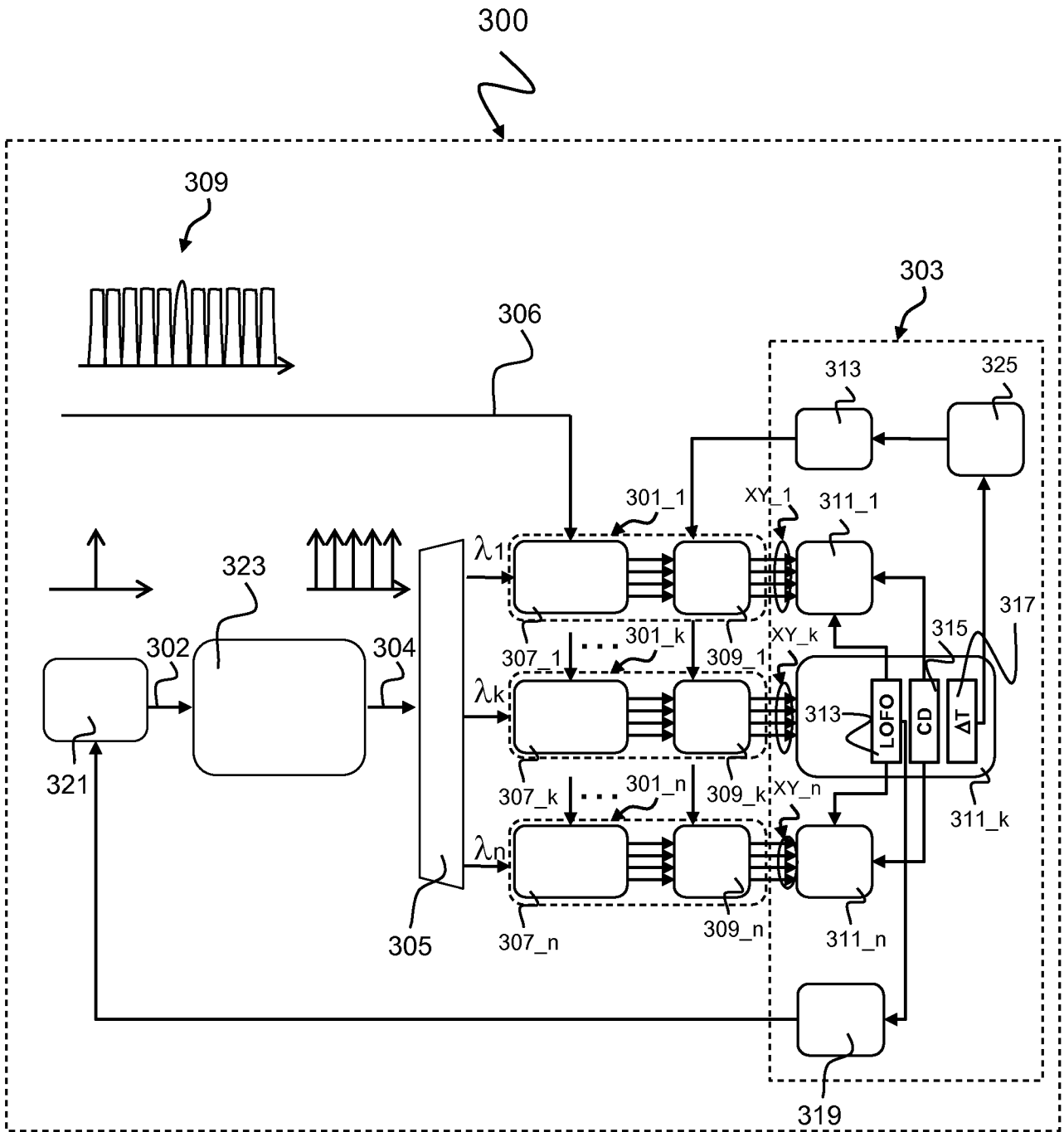

Fig. 3

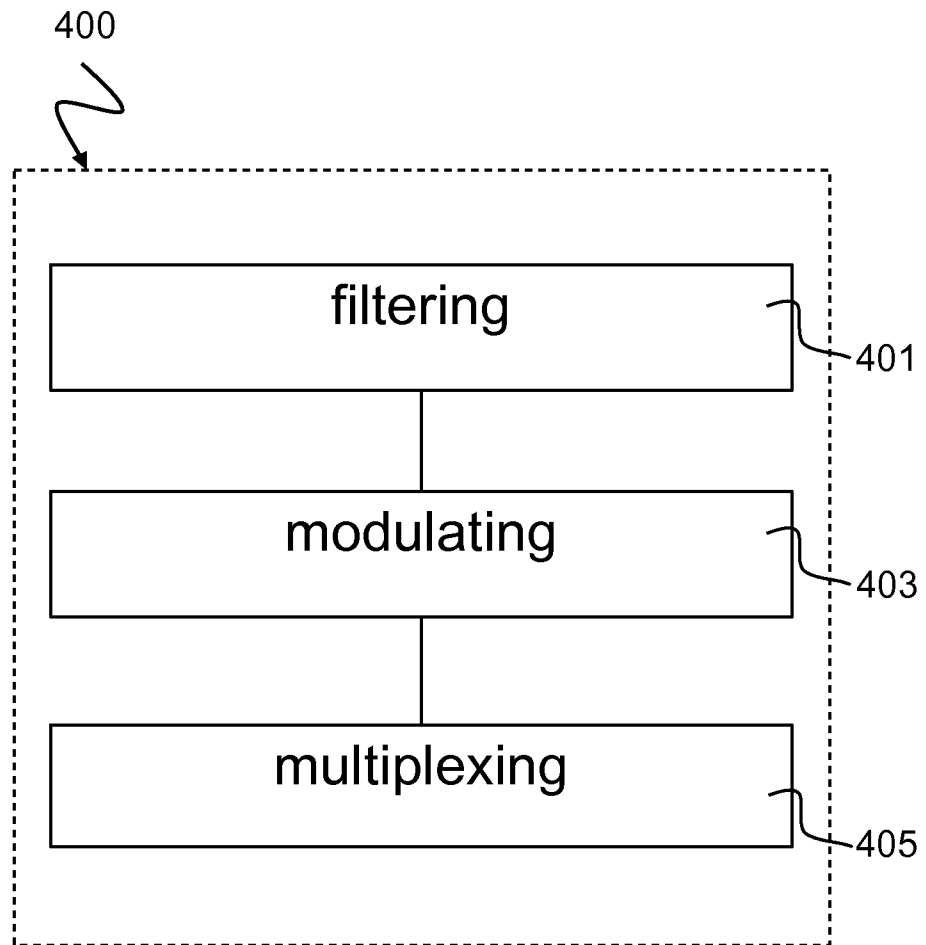

Fig. 4

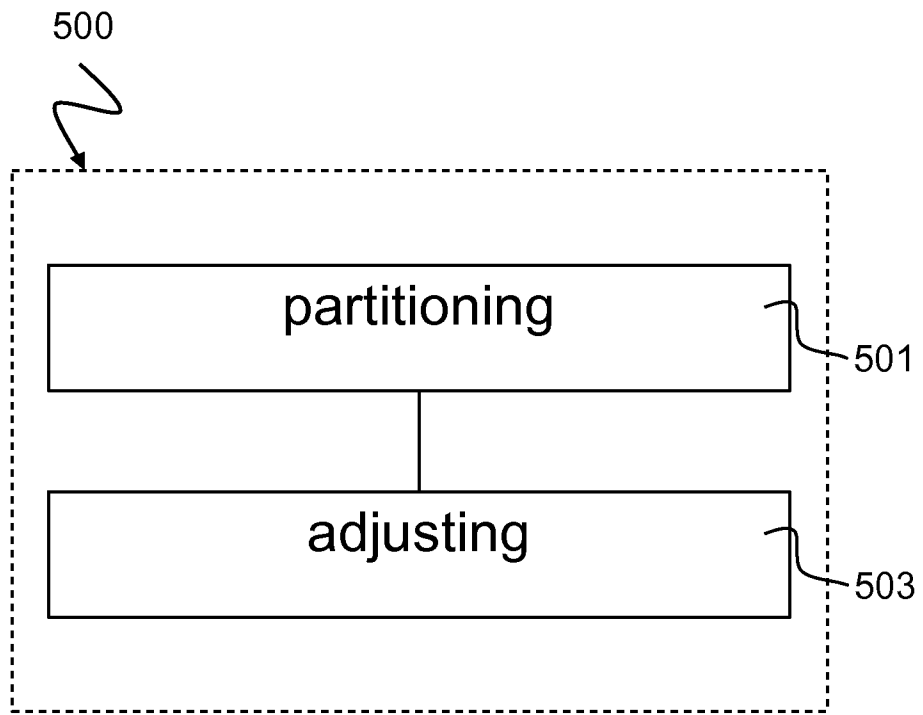

Fig. 5

INTERNATIONAL SEARCH REPORT

International application No
PCT/EP2013/051239

A. CLASSIFICATION OF SUBJECT MATTER
INV. H04L27/26
ADD.

According to International Patent Classification (IPC) or to both national classification and IPC

B. FIELDS SEARCHED
Minimum documentation searched (classification system followed by classification symbols)
H04L

Documentation searched other than minimum documentation to the extent that such documents are included in the fields searched

Electronic data base consulted during the international search (name of data base and, where practicable, search terms used)
EPO-Internal, WPI Data

C. DOCUMENTS CONSIDERED TO BE RELEVANT

Category*	Citation of document, with indication, where appropriate, of the relevant passages	Relevant to claim No.
X	EP 2 312 770 A1 (ALCATEL LUCENT [FR]) 20 April 2011 (2011-04-20) the whole document	1-15
X	SANO AKIHIDE ED - DINGEL BENJAMIN ET AL: "Recent progress in coherent optical communication technologies", BROADBAND ACCESS COMMUNICATION TECHNOLOGIES V, SPIE, 1000 20TH ST. BELLINGHAM WA 98225-6705 USA, vol. 7958, no. 1, 22 January 2011 (2011-01-22), pages 1-7, XP060010791, DOI: 10.1117/12.877243 [retrieved on 1901-01-01] the whole document	1-15

Further documents are listed in the continuation of Box C.

See patent family annex.

* Special categories of cited documents :

"A" document defining the general state of the art which is not considered to be of particular relevance

"E" earlier application or patent but published on or after the international filing date

"L" document which may throw doubts on priority claim(s) or which is cited to establish the publication date of another citation or other special reason (as specified)

"O" document referring to an oral disclosure, use, exhibition or other means

"P" document published prior to the international filing date but later than the priority date claimed

"T" later document published after the international filing date or priority date and not in conflict with the application but cited to understand the principle or theory underlying the invention

"X" document of particular relevance; the claimed invention cannot be considered novel or cannot be considered to involve an inventive step when the document is taken alone

"Y" document of particular relevance; the claimed invention cannot be considered to involve an inventive step when the document is combined with one or more other such documents, such combination being obvious to a person skilled in the art

"&" document member of the same patent family

Date of the actual completion of the international search 11 November 2013	Date of mailing of the international search report 15/11/2013
---	--

Name and mailing address of the ISA/ European Patent Office, P.B. 5818 Patentlaan 2 NL - 2280 HV Rijswijk Tel. (+31-70) 340-2040, Fax: (+31-70) 340-3016	Authorized officer González Gutiérrez
--	--

INTERNATIONAL SEARCH REPORT

International application No
PCT/EP2013/051239

C(Continuation). DOCUMENTS CONSIDERED TO BE RELEVANT		
Category*	Citation of document, with indication, where appropriate, of the relevant passages	Relevant to claim No.
X	WO 2012/107681 A1 (FRANCE TELECOM [FR]; BLOUZA SOFIENE [TN]; KARAKI JULIE [LB]; PINCEMIN) 16 August 2012 (2012-08-16) the whole document	1-15
X	----- YAN TANG ET AL: "Coherent Optical OFDM Transmission Up to 1 Tb/s per Channel", JOURNAL OF LIGHTWAVE TECHNOLOGY, IEEE SERVICE CENTER, NEW YORK, NY, US, vol. PP, no. 16, 15 August 2009 (2009-08-15), pages 3511-3517, XP011262208, ISSN: 0733-8724 the whole document	1-15
A	----- OLIVEIRA J C R F ET AL: "100G and beyond: optical transmission activities in Brazil", OPTICAL METRO NETWORKS AND SHORT-HAUL SYSTEMS IV, SPIE, 1000 20TH ST. BELLINGHAM WA 98225-6705 USA, vol. 8283, no. 1, 21 January 2012 (2012-01-21), pages 1-11, XP060001006, DOI: 10.1117/12.915901 [retrieved on 2012-01-24] the whole document	1-15

INTERNATIONAL SEARCH REPORT

Information on patent family members

International application No PCT/EP2013/051239

Patent document cited in search report	Publication date	Patent family member(s)	Publication date
EP 2312770	A1	20-04-2011	AT 556498 T 15-05-2012
			CN 102577186 A 11-07-2012
			EP 2312770 A1 20-04-2011
			ES 2383645 T3 25-06-2012
			JP 2013507868 A 04-03-2013
			KR 20120073325 A 04-07-2012
			US 2012189311 A1 26-07-2012
			WO 2011045217 A1 21-04-2011

WO 2012107681	A1	16-08-2012	FR 2971656 A1 17-08-2012
			WO 2012107681 A1 16-08-2012
