



- (51) International Patent Classification:
C23C 14/50 (2006.01)
- (21) International Application Number:
PCT/EP2009/003998
- (22) International Filing Date:
4 June 2009 (04.06.2009)
- (25) Filing Language: English
- (26) Publication Language: English
- (30) Priority Data:
884/08 11 June 2008 (11.06.2008) CH
- (71) Applicant (for all designated States except US): OERLIKON TRADING AG, TRÜBBACH [CH/CH]; Hauptstrasse, CH-9477 Trübbach (CH).
- (72) Inventor; and
- (75) Inventor/Applicant (for US only): ESSER, Stefan [DE/DE]; Richtericher Strasse 80, 52072 Aachen (DE).
- (74) Agent: WAGNER, Wolfgang H.; Zimmerli, Wagner & Partner AG, Löwenstrasse 19, P.O. Box, CH-8021 Zürich (CH).

(81) Designated States (unless otherwise indicated, for every kind of national protection available): AE, AG, AL, AM, AO, AT, AU, AZ, BA, BB, BG, BH, BR, BW, BY, BZ, CA, CH, CL, CN, CO, CR, CU, CZ, DE, DK, DM, DO, DZ, EC, EE, EG, ES, FI, GB, GD, GE, GH, GM, GT, HN, HR, HU, ID, IL, IN, IS, JP, KE, KG, KM, KN, KP, KR, KZ, LA, LC, LK, LR, LS, LT, LU, LY, MA, MD, ME, MG, MK, MN, MW, MX, MY, MZ, NA, NG, NI, NO, NZ, OM, PG, PH, PL, PT, RO, RS, RU, SC, SD, SE, SG, SK, SL, SM, ST, SV, SY, TJ, TM, TN, TR, TT, TZ, UA, UG, US, UZ, VC, VN, ZA, ZM, ZW.

(84) Designated States (unless otherwise indicated, for every kind of regional protection available): ARIPO (BW, GH, GM, KE, LS, MW, MZ, NA, SD, SL, SZ, TZ, UG, ZM, ZW), Eurasian (AM, AZ, BY, KG, KZ, MD, RU, TJ, TM), European (AT, BE, BG, CH, CY, CZ, DE, DK, EE, ES, FI, FR, GB, GR, HR, HU, IE, IS, IT, LT, LU, LV, MC, MK, MT, NL, NO, PL, PT, RO, SE, SI, SK, TR), OAPI (BF, BJ, CF, CG, CI, CM, GA, GN, GQ, GW, ML, MR, NE, SN, TD, TG).

Published:

— with international search report (Art. 21(3))

(54) Title: WORKPIECE CARRIER

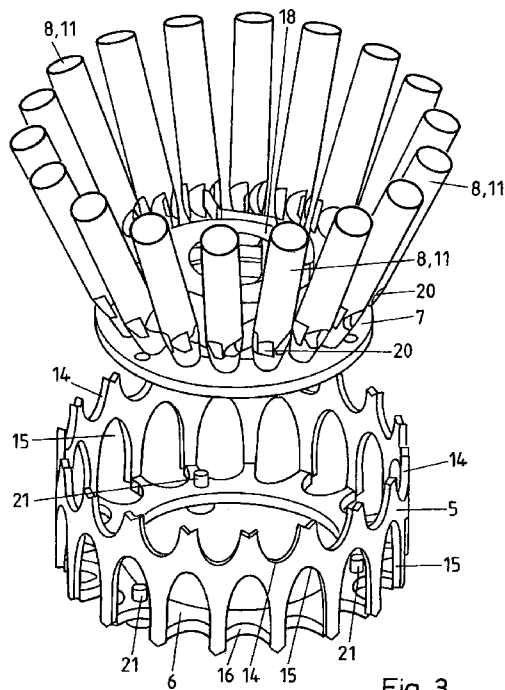

(57) Abstract: A plurality of discs (7) arranged along a central shaft and having holders (8) uniformly distributed over the circumference, inclined obliquely outwards and intended for workpieces are supported in each case on a ring (5) surrounding the discs (7). The successive rings (5) form an approximately cylindrical cladding which prevents undesired coating of the discs (7). The cladding has groups of openings for the holders (8) of a disc (7) which are uniformly distributed over the circumference at the same height and each of which is formed by an upper recess (14) in the ring (5) carrying the disc (7) and an adjacent lower recess (15) of the following ring. Boundary lines (17) between successive rings (5) start in each case somewhat below the narrowest points of the webs separating adjacent openings, so that the lower recesses (15) in each case do not narrow towards the edge of the ring (5) and the upper recesses (14) narrow at most slightly in such a way that the workpiece carrier can be assembled from bottom to top without difficulties.

D E S C R I P T I O N**WORKPIECE CARRIER****Field of the invention**

The invention relates to a workpiece carrier for a coating
5 system according to the precharacterizing clause of Claim 1.
A workpiece carrier of this type usually carries, in
corresponding holders, a relatively large number of
workpieces which are transported past coating sources
several times to ensure a coating which is as uniform as
10 possible.

Prior art

DE 10 2004 027 989 A1 discloses a workpiece carrier of the
generic type. In particular, it has holders inclined
outwards obliquely away from the shaft, which permits a very
15 close arrangement of the workpieces and also leads to a
generally desired increase in the thickness of the coating
towards the end face of the workpiece and improves the
uniformity of the coating especially on end faces.

However, a disadvantage is that the discs carrying the
20 holders, and other parts, are inevitably also coated. This
requires regular cleaning, which must be effected very
carefully in order to avoid damage to sensitive components,
with corresponding cost, reduction of the times in use and
increase of wear.

25 A similar workpiece carrier is disclosed in EP 1 256 637 A1.
Here, the holders are aligned parallel to a rotating central
shaft which drives the discs. Neither the discs nor the

shaft nor further parts producing in each case rotation of the holder itself are protected from coating.

Summary of the invention

It is the object of the invention to provide a workpiece
5 carrier of the generic type, in which the discs carrying the holders are protected from undesired coating. This object is achieved by the features in the characterizing clause of Claim 1.

In the workpiece carrier according to the invention, the
10 shaft, the discs and the lower parts of the holders are covered by a cladding which has a very simple design and is easy to mount and to remove and can be cleaned easily and without danger of damage. The cladding can also serve further purposes, such as establishing the spacing of
15 directly successive discs.

Brief description of the drawings

Below, the invention is explained in more detail with reference to figures, which merely represent embodiments.

Fig. 1 schematically shows an axial longitudinal section
20 through a workpiece carrier according to the invention, in a first embodiment,

Fig. 2 shows a partial side view of the workpiece carrier according to the invention, of Fig. 1, and

Fig. 3 shows a partial exploded view of a workpiece
25 carrier according to the invention, in a second embodiment.

Description of the preferred embodiments

For simplification of the presentation, the workpiece carrier according to Fig. 1, 2 is shown somewhat schematically and is also provided with fewer holders for 5 workpieces than will usually be provided.

It has a central perpendicular shaft 1 of non-rotationally symmetrical, preferably square, cross-section which is connected to a base 2. It can be mounted on an axis coinciding with the centre of the shaft 1 so as to be non-rotatable relative to the base 2 or rotatable about said 10 axis and can be driveable. A gear ring 3 mounted so as to be rotatable about said axis engages a driveable pinion 4 and is driven by the latter in such a way that its rotational speed differs from that of the shaft 1 so that the gear ring 15 3 executes a rotational movement relative to the shaft 1. Rings 5 of a thin rigid material, e.g. sheet metal, which in each case are of substantially cylindrical shape and together form a cylindrical cladding, are present non-rotatably in succession in the axial direction on the gear 20 ring 3. At the lower end of a ring 5, an annular support ring 6 on which an annular disc 7 surrounding the shaft 1 is supported, likewise non-rotatably, is fastened in each case to the inside.

Each disc 7 carries an equal number - in the example six, as 25 a rule preferably more - of identical holders inclined outwards obliquely away from the shaft 1. Each of the holders 8 comprises a bolt 9 which is anchored in an oblique bore 10 in the disc 7 and a sleeve 11 rotatably mounted on the bolt 9 and having a bore 12 for receiving a workpiece 13 30 (omitted in Fig. 2).

The holders 8 are distributed in each case uniformly over the circumference of the disc 7 so that adjacent holders are offset relative to one another in each case by the same angular pitch - 60° in the example. The rings 5 - with the exception of the uppermost ring which is not shown - each have, at the upper edge, a number of upper recesses 14 uniformly distributed over the circumference, which number corresponds to the number of holders 8, and - with the exception of the lowermost ring - likewise, at the lower edge, uniformly distributed lower recesses 15 which however are offset in each case by half the angular pitch relative to the upper recesses 14 so that one of the upper recesses 14 is in each case centred between two lower recesses 15, and vice versa.

Successive rings 5 are oriented so that the lower recesses 15 of the upper ring 5 are adjacent in each case to the upper recesses 14 of the lower ring 5, in particular so that the edges of the latter constitute a smooth continuation of those of the former. The lower recess 15 and the upper recess 14 adjacent to it together form in each case an opening in the cladding through which one of the holders 8 projects, it also being necessary for a recess 16 to be provided in each case at the outer edge of the support ring 6 of the upper ring 5. The openings which belong to a group formed in this manner between two rings are at the same height and are distributed uniformly over the circumference of the cladding. The openings which are preferably identical throughout may each have an elongated elliptical shape or a similar shape, for example may be in the form of semi-ellipses of identical or different lengths which are connected by a rectangular central piece. The rings 5 abut one another along boundary lines 17 which are led in the circumferential direction in such a way that they connect in

each case adjacent openings, i.e. intersect the webs separating them, and do so in such a way that they start in the vicinity of the narrowest point between said openings, and preferably somewhat below said point, it being necessary
5 to ensure that the upper recesses 14 narrow only to such an extent that their width is at least slightly greater even at the lower end than the diameter of the holders 8, i.e. of their sleeves 11.

The boundary line 17 is formed so that adjacent rings 5 are
10 fixed in a required position with respect to their mutual angular position, apart from rotations through a multiple of the angular pitch. In addition, it is chosen so that said angular position automatically adopts a fixed required position if the upper ring is mounted so that it is rotated
15 by less than half the angular pitch. This is achieved in the example by virtue of the fact that the boundary line 17 follows a preferably symmetrical V-shaped line with a lowest point in the middle between the adjacent openings which it connects. As a result, the web sections which separate
20 adjacent lower recesses 15 slide when they rest on a sleeve 11 of a recess 8, in each case on said sleeve in such a way that the ring is automatically rotated towards the required position. Transversely thereto, the relative position of successive rings 5 can be controlled by stops which project,
25 for example, on the inside of a ring slightly above the boundary line 17 and cooperate there with the inside of the following ring. The stops can (cf. Fig. 3) be formed, for example, by parts of the support ring 6. They can, however, also be absent since the effective formation of the boundary
30 lines 17 over the total circumference forces the ring 5 to assume the required position in each direction.

In order to produce a rotation of each holder 8 itself, a transmission part 18 is coordinated with each of the discs 7, which transmission part 18 is preferably a part which is punched from a metal sheet and bent and which engages the shaft 1 in a displaceable but non-rotatable manner, for example by having a square recess through which said shaft projects and which is connected to the respective disc 7 in such a way that it is rotatable relative to said disc but is not displaceable or at most has limited displaceability axially, parallel to the shaft 1. It has lugs 19 which project radially outwards and engage rotary stops on the holders 8, which rotary stops are each in the form of notches 20 in the sleeve 11.

The workpiece carrier can be assembled by first mounting the lowermost ring 5 on the gear ring 3, then the lowermost disc 7, together with the corresponding transmission part 18 and the holders 8, on the support ring 6 thereof, then the next ring 5, etc.. Owing to the position and properties of the boundary lines 17, this does not give rise to any difficulties since the upper recesses 14 are just wide enough even at their lower ends to be able to receive the sleeves 11 of the holders 8, and the lower recesses 15 each widen towards the edge. The position of the discs 7 in the direction of the shaft 1 is completely fixed in each case by the position of the corresponding ring 5. The position of each ring 5 in turn results from its support on the next lower ring or on the gear ring 3. The rotational position of the rings 5 need be checked in each case only approximately during assembly since their relevant orientation is effected automatically by the contact with the holders 8 of the next lower disc and finally by the V-shape of the boundary lines 17.

Fig. 3 shows a realistic formation of a disc 7 having eighteen holders 8 and of a ring 5 coordinated with the disc 7 and having corresponding numbers of upper recesses 14, lower recesses 15 and recesses 16 on the support ring 6.

5 Rotation-preventing devices 21 which prevent rotation of the disc 7 relative to the ring 5 when the former rests on the support ring 6 are also visible on the same. As is evident, the webs between adjacent openings are very narrow and the upper recesses 14 in turn are offset relative to the lower

10 recesses 15 by half an angular pitch. This permits an overall very dense arrangement of the holders 8 on the workpiece carrier. The boundary lines 17 between adjacent openings are once again V-shaped with a lowest point in the middle.

15 Apart from the absence of lower recesses in the case of the lowermost and upper recesses in the uppermost ring and any further peculiarities of these two rings, all rings as well as all discs are identically formed in each case so that all openings are also identical. The rings are in each case

20 invariant with rotation about a multiple of the angular pitch. Each of the rings is coordinated with one of the discs and determines the distance between said disc and the following disc.

In this respect and also otherwise, however, substantial

25 deviations from the examples described are possible without departing from the scope of the invention. Thus, the cladding and the rings can also have a shape other than substantially cylindrical. Moreover, the number of openings of the groups - corresponding to the number of holders of

30 the discs - can vary. The shaft may consist of a plurality of sections which are connected non-rotatably to one another and to which in each case one transmission means can then

also be firmly connected. The workpiece carrier may also have a more complex design than described, for example with a plurality of units having the design described and being present on a base rotatable about an axis.

5 **List of reference symbols**

	1	Shaft
	2	Base
	3	Gear ring
	4	Pinion
10	5	Ring
	6	Support ring
	7	Disc
	8	Holder
	9	Bolt
15	10	Bore
	11	Sleeve
	12	Bore
	13	Workpiece
	14	Upper recess
20	15	Lower recess
	16	Recess
	17	Boundary line
	18	Transmission part
	19	Lug
25	20	Notch
	21	Rotation-preventing device

P A T E N T C L A I M S

1. Workpiece carrier for a coating system, comprising a base (2) and a shaft (1) anchored or mounted therein and a plurality of discs (7) which follow one another
5 along the shaft (1) and are rotatable relative to the base (2) and which in each case are provided with a plurality of holders (8) distributed over the circumference of the disc (7), inclined obliquely outwards away from the shaft (1) and intended for a
10 workpiece (13), **characterized in that** said workpiece carrier has a cladding which surrounds the shaft (1) and the discs (7) and leaves free groups of openings which are distributed over the circumference and separated in each case by webs, through which openings
15 in each case the holders (8) belonging to one of the discs (7) project, and which is composed of a plurality of rings (5) which follow one another along the shaft (1) and are directly adjacent to one another and which abut at boundary lines (17) which in each case divide
20 one of the webs present between adjacent openings of a group.

2. Workpiece carrier according to Claim 1, **characterized in that** at least one boundary line (17) is formed, for example, in such a way that the mutual rotational
25 position of the adjacent rings (5) inevitably corresponds to a fixed required position.

3. Workpiece carrier according to Claim 2, **characterized in that** the at least one boundary line (17) is at least partly approximately V-shaped.

4. Workpiece carrier according to any of Claims 1 to 3,
characterized in that the openings of a group are of
the same size in each case, are located at the same
height and are distributed uniformly over the
5 circumference so that adjacent openings are offset
relative to one another in each case by a fixed angular
pitch.
5. Workpiece carrier according to Claim 4, **characterized
in that** each group has the same number of openings.
- 10 6. Workpiece carrier according to Claim 5, **characterized
in that** the openings of groups directly following one
another along the shaft (1) are offset in each case
relative to one another by half the angular pitch.
- 15 7. Workpiece carrier according to Claim 5 or 6,
characterized in that the rings (5) are formed in each
case so as to be invariant with rotation through the
angular pitch.
- 20 8. Workpiece carrier according to any of Claims 1 to 7,
characterized in that the rings (5) are identical,
apart from rings (5) at end positions.
9. Workpiece carrier according to any of Claims 1 to 8,
characterized in that the cladding has a substantially
cylindrical shape.
- 25 10. Workpiece carrier according to any of Claims 1 to 9,
characterized in that each disc (7) is supported on a
ring (5).

11. Workpiece carrier according to any of Claims 1 to 10,
characterized in that the discs (7) each surround the
shaft (1) in an annular manner.
12. Workpiece carrier according to any of Claims 1 to 11,
5 **characterized in that** the rings (5) each have, on the
inside, a stop on which in each case one of the discs
(7) is supported.
13. Workpiece carrier according to Claim 12, **characterized**
in that the stop is in the form of an all-round support
10 ring (6).
14. Workpiece carrier according to any of Claims 1 to 13,
characterized in that the holders (8) are each
rotatably mounted on the discs (7) and a transmission
part (18) which acts on rotary stops on the holders (8)
15 and which in each case non-rotatably engages the shaft
(1) is provided for each disc (7).
15. Workpiece carrier according to Claim 14, **characterized**
in that the transmission part (18) is in each case
axially displaceable on the shaft (1) and axially
20 nondisplaceable relative to the disc (7).

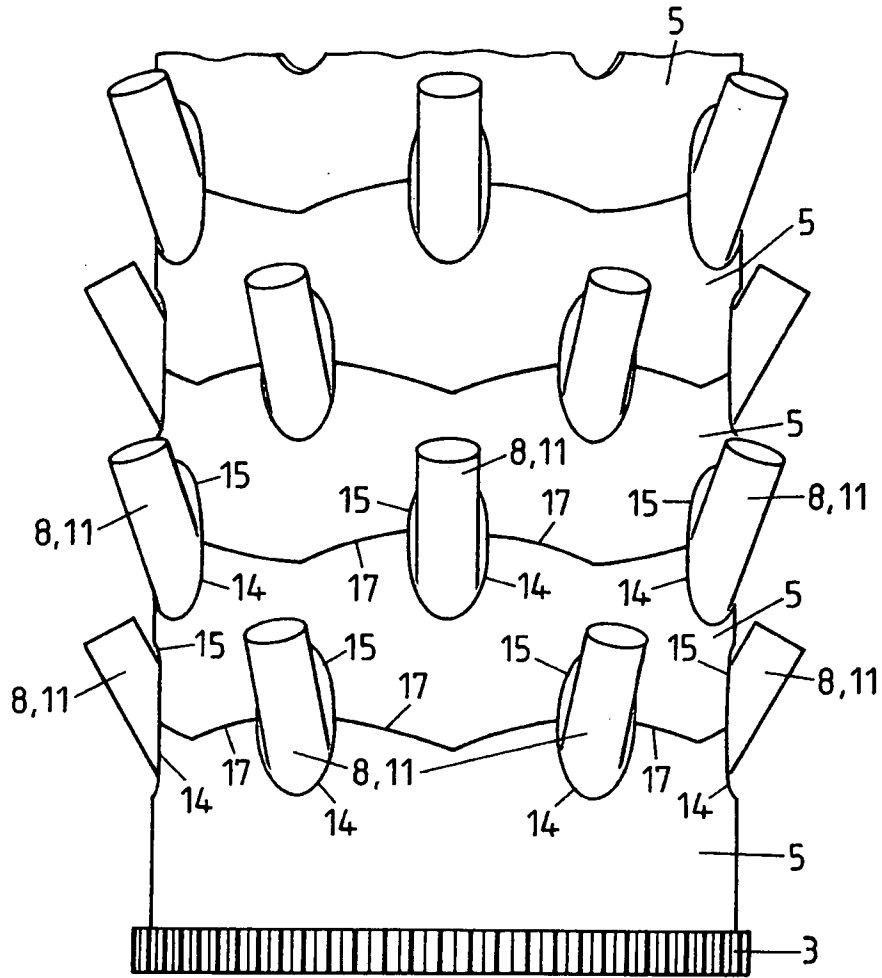

Fig. 2

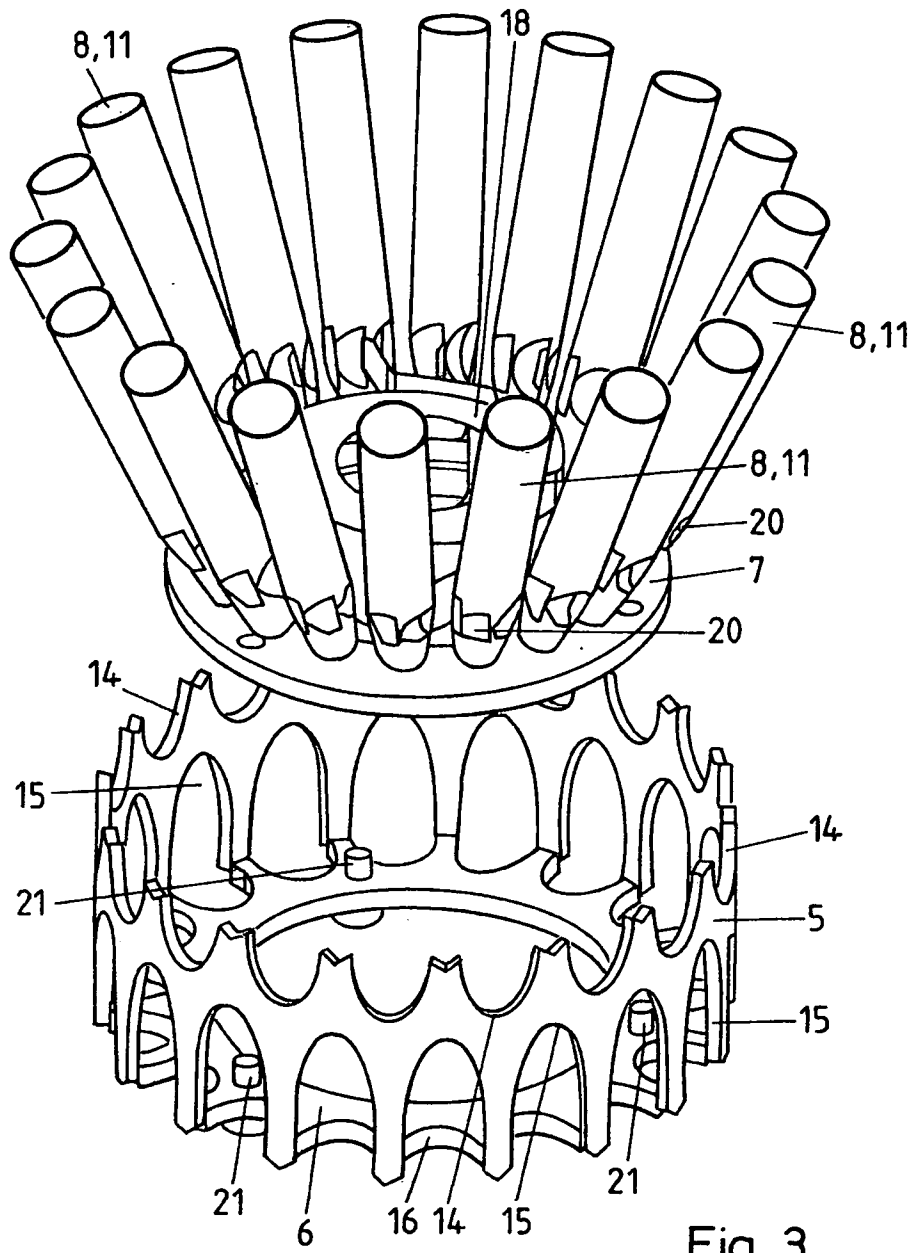

Fig. 3

INTERNATIONAL SEARCH REPORT

International application No
PCT/EP2009/003998

A. CLASSIFICATION OF SUBJECT MATTER INV. C23C14/50				
According to International Patent Classification (IPC) or to both national classification and IPC				
B. FIELDS SEARCHED				
Minimum documentation searched (classification system followed by classification symbols) C23C				
Documentation searched other than minimum documentation to the extent that such documents are included in the fields searched				
Electronic data base consulted during the international search (name of data base and, where practical, search terms used) EPO-Internal, WPI Data				
C. DOCUMENTS CONSIDERED TO BE RELEVANT				
Category*	Citation of document, with indication, where appropriate, of the relevant passages	Relevant to claim No.		
A	DE 10 2004 027989 A1 (ESSER STEFAN [DE]) 2 March 2006 (2006-03-02) cited in the application figure 6	1		
A	US 2002/062791 A1 (GINOVKER ANDREY [CA] ET AL) 30 May 2002 (2002-05-30) paragraph [0090]; figure 14	1		
<input type="checkbox"/> Further documents are listed in the continuation of Box C.				
<input checked="" type="checkbox"/> See patent family annex.				
* Special categories of cited documents :				
<table style="width: 100%; border: none;"> <tr> <td style="width: 50%; border: none; vertical-align: top;"> *A* document defining the general state of the art which is not considered to be of particular relevance *E* earlier document but published on or after the international filing date *L* document which may throw doubts on priority claim(s) or which is cited to establish the publication date of another citation or other special reason (as specified) *O* document referring to an oral disclosure, use, exhibition or other means *P* document published prior to the international filing date but later than the priority date claimed </td> <td style="width: 50%; border: none; vertical-align: top;"> *T* later document published after the international filing date or priority date and not in conflict with the application but cited to understand the principle or theory underlying the invention *X* document of particular relevance; the claimed invention cannot be considered novel or cannot be considered to involve an inventive step when the document is taken alone *Y* document of particular relevance; the claimed invention cannot be considered to involve an inventive step when the document is combined with one or more other such documents, such combination being obvious to a person skilled in the art. *&* document member of the same patent family </td> </tr> </table>			*A* document defining the general state of the art which is not considered to be of particular relevance *E* earlier document but published on or after the international filing date *L* document which may throw doubts on priority claim(s) or which is cited to establish the publication date of another citation or other special reason (as specified) *O* document referring to an oral disclosure, use, exhibition or other means *P* document published prior to the international filing date but later than the priority date claimed	*T* later document published after the international filing date or priority date and not in conflict with the application but cited to understand the principle or theory underlying the invention *X* document of particular relevance; the claimed invention cannot be considered novel or cannot be considered to involve an inventive step when the document is taken alone *Y* document of particular relevance; the claimed invention cannot be considered to involve an inventive step when the document is combined with one or more other such documents, such combination being obvious to a person skilled in the art. *&* document member of the same patent family
A document defining the general state of the art which is not considered to be of particular relevance *E* earlier document but published on or after the international filing date *L* document which may throw doubts on priority claim(s) or which is cited to establish the publication date of another citation or other special reason (as specified) *O* document referring to an oral disclosure, use, exhibition or other means *P* document published prior to the international filing date but later than the priority date claimed	*T* later document published after the international filing date or priority date and not in conflict with the application but cited to understand the principle or theory underlying the invention *X* document of particular relevance; the claimed invention cannot be considered novel or cannot be considered to involve an inventive step when the document is taken alone *Y* document of particular relevance; the claimed invention cannot be considered to involve an inventive step when the document is combined with one or more other such documents, such combination being obvious to a person skilled in the art. *&* document member of the same patent family			
Date of the actual completion of the international search <p style="text-align: center; font-size: 1.2em;">1 September 2009</p>	Date of mailing of the international search report <p style="text-align: center; font-size: 1.2em;">08/09/2009</p>			
Name and mailing address of the ISA/ European Patent Office, P.B. 5818 Patentlaan 2 NL - 2280 HV Rijswijk Tel. (+31-70) 340-2040, Fax: (+31-70) 340-3016	Authorized officer <p style="text-align: center; font-size: 1.2em;">Schuhmacher, Jörg</p>			

INTERNATIONAL SEARCH REPORT

Information on patent family members

International application No

PCT/EP2009/003998

Patent document cited in search report	Publication date	Patent family member(s)	Publication date
DE 102004027989 A1	02-03-2006	NONE	
US 2002062791 A1	30-05-2002	NONE	