

(No Model.)

A. CLAYPOOL.
HINGE.

No. 376,027.

Patented Jan. 3, 1888.

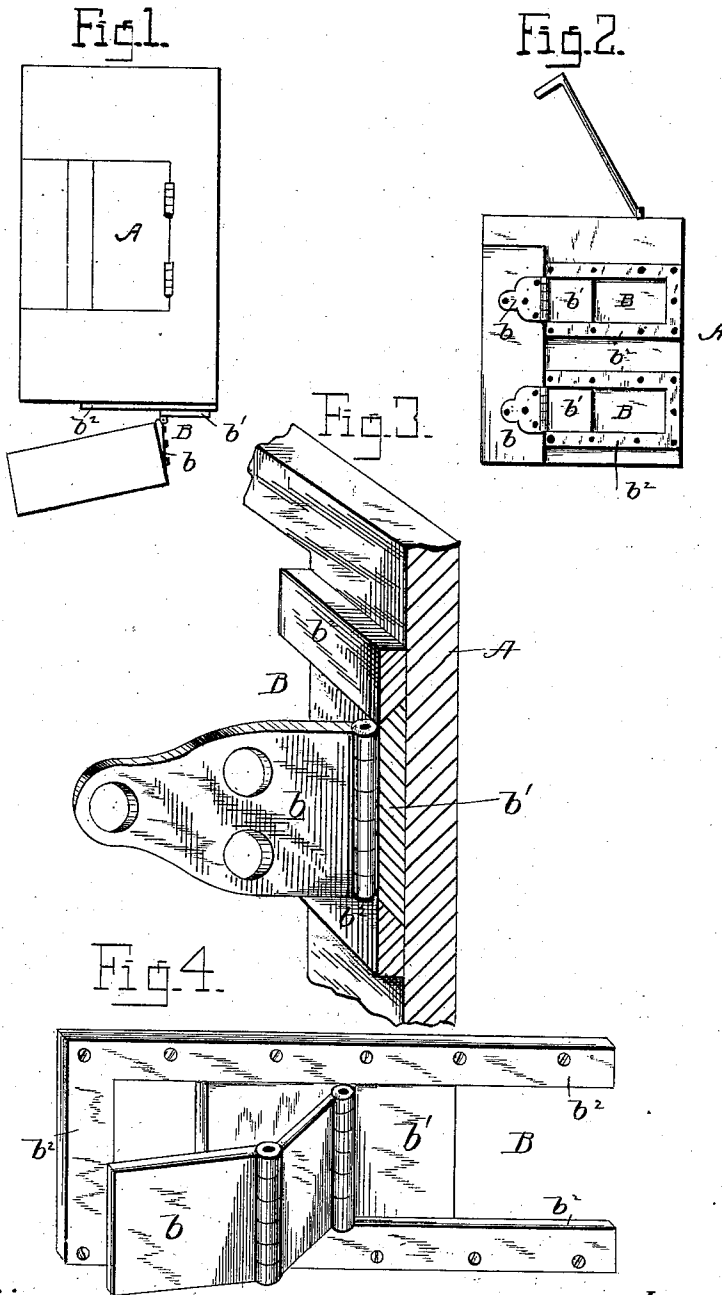

Witnesses:

W. E. Aughinbaugh
H. F. Riley

Inventor :

by *Albert Claypool,*
A. S. Dyerforth,
his Attorney.

UNITED STATES PATENT OFFICE.

ALBERT CLAYPOOL, OF TOLEDO, OHIO.

HINGE.

SPECIFICATION forming part of Letters Patent No. 376,027, dated January 3, 1888.

Application filed August 11, 1887. Serial No. 246,703. (No model.)

To all whom it may concern:

Be it known that I, ALBERT CLAYPOOL, a citizen of the United States, residing at Toledo, in the county of Lucas and State of Ohio, have
5 invented certain new and useful Improvements in Hinges; and I do hereby declare the following to be a full, clear, and exact description of the invention, such as will enable others skilled in the art to which it appertains to
10 make and use the same.

This invention relates to hinges.

The object is to produce a hinge which will permit whatever it supports to be slid to one side and placed out of the way when not in
15 use, and which will be simple and economic of construction.

The invention consists in a hinge comprising pivoted leaves, one of which leaves is beveled or dovetailed and is adapted to slide or
20 move in dovetailed guideways; and, furthermore, in various novel details of construction wherein the desired object is attained.

The accompanying drawings illustrate my invention, in which like letters of reference indicate corresponding parts in all the figures.

Figure 1 represents an end elevation of a cabinet with my invention applied. Fig. 2 represents a plan view of the same, showing the supported portion or movable section removed to one side. Fig. 3 represents a detail sectional view of the hinge, taken through the guides or ways; and Fig. 4 represents a
30 modification.

The invention, for the purpose of illustration, is here shown applied to a cabinet, although it will at once be obvious that it may be applied to any movable or swinging body where a device of this kind is required. The cabinet is designated by A, and to a suitable
40 part of this the main portion of the hinge B is attached. This hinge, which is made of any suitable material, is composed of the leaves or plates *b* and *b'*, the portion *b* in this instance being attached to a movable section, *a*, of the cabinet, which section, when the cabinet is
45 closed, serves as a door, and the leaf or plate *b'* being movably attached to the stationary portion of the cabinet by means of guides or ways *b''*, secured to the side of the cabinet and

provided with beveled inner edges, *b''*, to fit
50 the beveled outer edges of the sliding portion of the hinge. The sliding leaf or plate is constructed with its side edges beveled, and the said plate moves or slides in the dovetailed guides or ways, which guides or ways may be
55 of any desired length in order to permit the door or other object which is attached to the outer pivoted leaf to be slid back out of the way for any desired distance. The leaf or plate *b'* is capable of being slid back and forth
60 in the guides or ways, so that when the section *a* is turned back upon its hinges to bring its inner face in plane with the face of the stationary section the movable section may be
65 slid back to any desired extent to expose the interior of the cabinet, and thus be out of the way.

This hinge I have illustrated in an application for Letters Patent on an improvement in medicine-cases filed by me August 20, 1886,
70 and patented September 6, 1887, No. 369,590; but in that case no claim was made to the hinge as here shown.

The modification shown in Fig. 4 of the drawings represents a hinge adapted to use
75 where thick doors are required, as in a safe or the like, and for this purpose the hinge is formed with a central portion pivotally connecting its two leaves. This allows greater swing of the door, thus accomplishing the ob-
80 ject for which it is designed.

Having thus fully described my invention, what I claim as new, and desire to secure by Letters Patent, is—

The herein-described hinge, comprising the
85 pivoted leaves, one of which is beveled or dovetailed on its side edges, and the longitudinal beveled or dovetailed guideways in which the dovetailed leaf fits and is adapted to slide laterally, for the purpose set forth,
90 substantially as described.

In testimony whereof I affix my signature in presence of two witnesses.

ALBERT CLAYPOOL.

Witnesses:

L. K. PARKS,
WM. WATTS.