



- (51) International Patent Classification:  
*B61D 3/18* (2006.01) *B60P 3/08* (2006.01)
- (21) International Application Number:  
PCT/US2015/037908
- (22) International Filing Date:  
26 June 2015 (26.06.2015)
- (25) Filing Language: English
- (26) Publication Language: English
- (30) Priority Data:  
62/018,298 27 June 2014 (27.06.2014) US  
14/750,818 25 June 2015 (25.06.2015) US
- (71) Applicant: **TRINITY NORTH AMERICA FREIGHT CAR, INC.** [US/US]; 2525 Stemmons Freeway, Dallas, TX 75207 (US).
- (72) Inventors: **CENCER, Robert, J.**; 626 Breyman Hwy., Tipton, MI 49287 (US). **BROWN, Andrew**; 3401 Michael Dr., Plano, TX 75023 (US). **COSTON, Kyle, R.**; 1031 Trickham Dr., Forney, TX 75126 (US). **MITZENBERG, James, R.**; 224 Steamboat Drive, Coppell, TX 75019 (US).
- (74) Agent: **WALTERS, Chad, C.**; Baker Botts L.L.P., Foreign Patent Department, 98 San Jacinto Blvd., 1500 San Jacinto Center, Austin, TX 78701 (US).

- (81) Designated States (unless otherwise indicated, for every kind of national protection available): AE, AG, AL, AM, AO, AT, AU, AZ, BA, BB, BG, BH, BN, BR, BW, BY, BZ, CA, CH, CL, CN, CO, CR, CU, CZ, DE, DK, DM, DO, DZ, EC, EE, EG, ES, FI, GB, GD, GE, GH, GM, GT, HN, HR, HU, ID, IL, IN, IR, IS, JP, KE, KG, KN, KP, KR, KZ, LA, LC, LK, LR, LS, LU, LY, MA, MD, ME, MG, MK, MN, MW, MX, MY, MZ, NA, NG, NI, NO, NZ, OM, PA, PE, PG, PH, PL, PT, QA, RO, RS, RU, RW, SA, SC, SD, SE, SG, SK, SL, SM, ST, SV, SY, TH, TJ, TM, TN, TR, TT, TZ, UA, UG, US, UZ, VC, VN, ZA, ZM, ZW.
- (84) Designated States (unless otherwise indicated, for every kind of regional protection available): ARIPO (BW, GH, GM, KE, LR, LS, MW, MZ, NA, RW, SD, SL, ST, SZ, TZ, UG, ZM, ZW), Eurasian (AM, AZ, BY, KG, KZ, RU, TJ, TM), European (AL, AT, BE, BG, CH, CY, CZ, DE, DK, EE, ES, FI, FR, GB, GR, HR, HU, IE, IS, IT, LT, LU, LV, MC, MK, MT, NL, NO, PL, PT, RO, RS, SE, SI, SK, SM, TR), OAPI (BF, BJ, CF, CG, CI, CM, GA, GN, GQ, GW, KM, ML, MR, NE, SN, TD, TG).

**Declarations under Rule 4.17:**

- as to applicant's entitlement to apply for and be granted a patent (Rule 4.17(ii))

**Published:**

- with international search report (Art. 21(3))

(54) Title: SYSTEM AND METHOD OF INCREASING VERTICAL CLEARANCE IN AUTORACKS

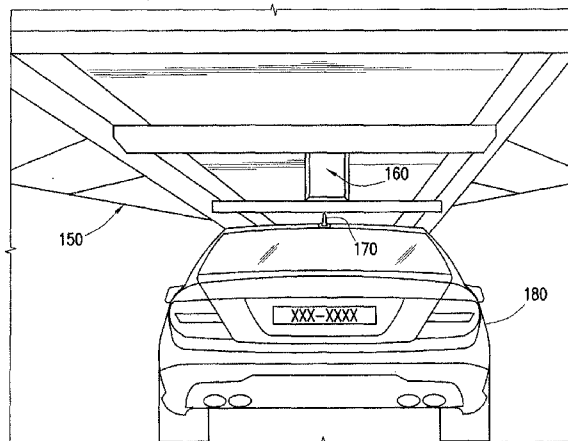

FIG. 2A

(57) Abstract: A system for increasing vertical clearance in an autorack includes an autorack comprising a plurality of decks. A first deck of the plurality of decks is positioned beneath a second deck of the plurality of decks. The second deck includes a clearance region proximate a center line of the second deck. A first portion of an underside surface of the second deck at the clearance region is higher than a second portion of the underside surface of the second deck not at the clearance region.

WO 2015/200763 A1

## SYSTEM AND METHOD FOR INCREASING VERTICAL CLEARANCE IN AUTORACKS

### **TECHNICAL FIELD**

[0001] The present disclosure relates generally to autoracks, and more particularly to a system and method for increasing vertical clearance in autoracks.

### **BACKGROUND**

[0002] Automobile manufacturers often transport vehicles via railroad lines on multi-deck railcars, such as autoracks. Many of the vehicles being transported on autoracks include GPS antenna pods or bases (“GPS antennas”), which may be centered on the roofs of the vehicles towards the rear lights (e.g., a top rear brake light) and thus may protrude above the rooflines of the vehicles. Further, the height of many of these vehicles has increased due to the current demand for taller vehicles. Accordingly, some of the loading positions of existing autoracks (especially those designed prior to roof-mounted GPS antennas) may need additional vertical clearance to account for the increased height in vehicle rooflines. Currently, to gain vertical clearance for certain loading positions (such as a loading position on an end of a slope deck positioned beneath a hinge deck (which often has limited vertical clearance)), the vehicles being loaded into those positions are being pulled farther down the end ramps of slope decks.

[0003] As a result, the bumper to bumper clearance between vehicles loaded on a slope deck (e.g., an “A” deck) often is only the minimum clearance recommended by the Association of American Railroads (“AAR”). Moreover, because the roofs of vehicles in the end positions of slope decks also must meet the minimum AAR recommended clearance and these positions may be limited in height, autorack loads are sometimes reduced by at least one vehicle (e.g., if a vehicle being loaded into an end loading position of a slope deck is too tall) to achieve the minimum recommended clearances on slope decks and to fully load the other decks. Reducing the load, however, increases shipping costs per vehicle when an entity shipping the vehicles is paying per autorack.

**SUMMARY**

**[0004]** The teachings of the present disclosure relate to a system and method for increasing vertical clearance in autoracks. In accordance with one embodiment, a system for increasing a vertical clearance in an autorack includes an autorack comprising a plurality of decks. A first deck of the plurality of decks is positioned beneath a second deck of the plurality of decks. The second deck includes a clearance region proximate a center line of the second deck. A first portion of an underside surface of the second deck at the clearance region is higher than a second portion of the underside surface of the second deck not at the clearance region.

**[0005]** In accordance with another embodiment, a method for increasing a vertical clearance in an autorack includes forming a clearance region proximate a center line of a first deck of an autorack. The first deck is positioned above a second deck of the autorack. A first portion of an underside surface of the first deck at the clearance region is higher than a second portion of the underside surface of the first deck not at the clearance region.

**[0006]** Technical advantages of particular embodiments may include providing vertical clearance regions in autoracks. Doing so may allow taller vehicles to be loaded on a deck of an autorack (such as an "A" deck ), increase bumper to bumper clearances, and increase the number of vehicles loaded onto an "A" deck of an autorack. For example, by providing vertical clearance regions for loading positions on "A" decks, vehicles loaded onto "A" deck end ramps (e.g., a loading position on an end of a slope deck positioned beneath a hinge deck) may be positioned further forward on the end ramps to allow as much bumper clearance for the vehicles loaded between those end ramps (rather than on the ends).

**[0007]** A further technical advantage includes increasing the vertical clearance of one or more loading positions of an autorack by modifying a center area of a hinge deck of an autorack directly above the loading positions for which additional vertical clearance is desired. Doing so may provide additional roof clearance for vehicles loaded in those positions, including vehicles with GPS antennas, which in turn may increase the load capacity of an autorack. Moreover, providing such clearance regions may increase vertical clearance in various positions of an autorack without reducing vertical clearance in other positions of the autorack.

**[0008]** Another technical advantage of particular embodiments may include providing a cover configured to be coupled to a hinge deck with a clearance region and disposed over at

least a portion of the clearance region. As such, additional clearance for a GPS antenna may be provided, and the corresponding vehicle in the below loading position may be protected from debris, snow and leaking fluids from an above level.

[0009] Yet another technical advantage includes a clearance region that may be retrofit to existing autoracks.

[0010] Other technical advantages will be readily apparent to one of ordinary skill in the art from the following figures, descriptions, and claims included herein. Moreover, while specific advantages have been enumerated above, certain embodiments of the present disclosure may include all, some, or none of the enumerated advantages.

### **BRIEF DESCRIPTION OF THE DRAWINGS**

[0011] A more complete and thorough understanding of the particular embodiments and advantages thereof may be acquired by referring to the following description taken in conjunction with the accompanying drawings, in which like reference numbers indicate like features, and wherein:

[0012] FIGURE 1A illustrates a side view of an example autorack of a system for increasing vertical clearance in an autorack in accordance with particular embodiments;

[0013] FIGURE 1B illustrates a side view of another example autorack of a system for increasing vertical clearance in an autorack in accordance with particular embodiments;

[0014] FIGURE 2A illustrates a perspective view of an example location for a clearance region in a deck of an autorack in accordance with particular embodiments;

[0015] FIGURE 2B illustrates a bottom view of an example clearance region formed in a hinge deck of a system for increasing vertical clearance in an autorack in accordance with particular embodiments;

[0016] FIGURE 3A illustrates a top view of an example clearance region of a hinge deck of a system for increasing vertical clearance in an autorack in accordance with particular embodiments;

[0017] FIGURE 3B illustrates a side view of an example clearance region of a hinge deck of a system for increasing vertical clearance in an autorack in accordance with particular embodiments;

[0018] FIGURE 3C illustrates a side view of an example clearance region with reinforcements formed in a deck of a system for increasing vertical clearance in an autorack in accordance with particular embodiments;

[0019] FIGURE 3D illustrates a side view of an example hinge deck with a cover disposed over at least a portion of a clearance region in accordance with particular embodiments;

[0020] FIGURE 4A illustrates a perspective view of another example clearance region formed in a hinge deck of a system for increasing vertical clearance in an autorack in accordance with particular embodiments;

[0021] FIGURE 4B illustrates a top view of another example clearance region formed in a hinge deck of a system for increasing vertical clearance in an autorack in accordance with particular embodiments;

[0022] FIGURE 4C illustrates a perspective view of another example hinge deck with a cover disposed over at least a portion of a clearance region in accordance with particular embodiments;

[0023] FIGURE 4D illustrates an end view of another example hinge deck with a cover disposed over at least a portion of a clearance region in accordance with particular embodiments;

[0024] FIGURE 4E illustrates a perspective view of an example clearance region formed in a deck of a system for increasing vertical clearance in an autorack in accordance with particular embodiments;

[0025] FIGURE 5 illustrates an end view of an example hinge deck with a clearance region in accordance with particular embodiments;

[0026] FIGURE 6 illustrates an end view of another example hinge deck with a clearance region in accordance with particular embodiments; and

[0027] FIGURE 7 illustrates an example method for increasing a vertical clearance of autorack according to particular embodiments.

**DETAILED DESCRIPTION**

[0028] Particular embodiments and their advantages are best understood by referring to FIGURES 1 through 7 of the drawings, like numerals being used for like and corresponding parts of the various drawings.

[0029] Automobile manufacturers often transport vehicles via railroad lines on multi-deck railcars, such as autoracks. Many of the vehicles being transported on autoracks include GPS antenna pods or bases (“GPS antennas”), which may be centered on the roofs of the vehicles towards the rear lights (e.g., a top rear brake light) and thus may protrude above the rooflines of the vehicles. Further, the height of many of these vehicles has increased due to the current demand for taller vehicles. Accordingly, some of the loading positions of existing autoracks (especially those designed prior to roof-mounted GPS antennas) may need additional vertical clearance to account for the increased height in vehicle rooflines. Currently, to gain vertical clearance for certain loading positions (such as a loading position on an end of a slope deck positioned beneath a hinge deck (which often has limited vertical clearance)), the vehicles being loaded into those positions are being pulled farther down the end ramps of slope decks.

[0030] As a result, the bumper to bumper clearance between vehicles loaded on a slope deck (e.g., an “A” deck) often is only the minimum clearance recommended by the Association of American Railroads (“AAR”). Moreover, because the roofs of vehicles in the end positions of slope decks also must meet the minimum AAR recommended clearance and these positions may be limited in height, autorack loads are sometimes reduced by at least one vehicle (e.g., if a vehicle being loaded into an end loading position of a slope deck is too tall) to achieve the minimum recommended clearances on slope decks and to fully load the other decks. Reducing the load, however, increases shipping costs per vehicle when an entity shipping the vehicles is paying per autorack. The teachings of this disclosure recognize that it would be desirable to provide clearance regions in hinge “B” decks to allow end vehicles with antennas to be pushed farther forward on the “A” deck end ramp, thereby providing the most bumper to bumper clearance for vehicles loaded between the end vehicles. Providing such clearance regions may increase vertical clearance in various positions of an autorack without reducing vertical clearance in other positions of the autorack. FIGURES 1 through 7 below illustrate a system and method for increasing vertical clearance in autoracks.

**[0031]** FIGURES 1A and 1B illustrate side views of example autoracks of a system for increasing vertical clearance in an autorack in accordance with particular embodiments. In general, system 100 includes an autorack 110. Autorack 110 may include a plurality of decks. A first deck of the plurality of decks may be positioned beneath a second deck of the plurality of decks. To provide additional vertical clearance in the first deck, the second deck may include a clearance region proximate to a center line of the second deck. For example, a first portion of an underside surface of the second deck at the clearance region may be higher than a portion of the underside surface of the second deck not at the clearance region.

**[0032]** An autorack 110 may comprise any type of carrier capable of transporting vehicles. Examples of autoracks 110 may include railcars, trailers, tractor trailers, ships, and/or any other carrier capable of transporting vehicles. In certain embodiments, an autorack 110 may be a tri-level autorack. Examples of vehicles that autorack 110 may transport include cars, trucks, buses, boats, aircrafts, any other automobile, or any combination of the preceding. One or more of these vehicles may include roof-mounted GPS antennas. Such roof-mounted GPS antennas generally increase the total height of the corresponding vehicles. To ensure minimum clearance thresholds are met, system 100 generally increases the vertical clearance of one or more loading positions of autorack 110, as described below.

**[0033]** In general, autorack 110 includes levels 120 and decks 130. Levels 120 may include an “A” level 120a, a “B” level 120b, and a “C” level 120c, in certain embodiments. Each level 120 may be associated with various loading positions for which a vehicle may be loaded and secured for transportation. For example, as shown in FIGURE 1B, “A” level 120a may be associated with positions A1, A2, A3, A4, and A5. In such an example, positions A1 through A5 may each house a vehicle being transported by autorack 110. According to various embodiments, the vehicles may be loaded and secured into the various loading positions of levels 120 via decks 130. Although autorack 110 was described as including certain positions and levels 120, this disclosure contemplates autorack 110 including any number and combination of positions and levels 120.

**[0034]** Each level 120 may be associated with a corresponding deck 130. Decks 130 may facilitate the loading, transportation, and/or unloading of vehicles associated with autorack 110. Examples of decks 130 include an “A” deck 130a, a “B” deck 130b, and a “C” deck 130c. Decks 130 may include deck plates. Deck plates may include flat/structural steel

plates, corrugated steel plates, any other suitable types of plates of any suitable material, or any combination of the preceding.

**[0035]** In certain embodiments, decks 130 may include inner deck portions and outer deck portions and/or may include multiple deck types. For example, the outer deck portions of “A” deck 130a may include slope decks 140. Slope decks 140 may be sloped or otherwise angled to clear the draft gear housing of autorack 110. In certain embodiments, slope decks 140 may be associated with loading positions A1 and A5. In such embodiments, slope decks 140 may reduce a vertical height of positions A1 and A5, limiting the amount of roof clearance for vehicles loaded in these positions. As another example, the outer deck portions of “B” deck 130b may include hinge decks 150. In certain embodiments, hinge decks 150 may be located above positions A1 and A5. In some embodiments, “C” deck 130c may include slope decks and/or hinge decks. The present disclosure contemplates decks 130 including any number and combination of decks 130, slope decks 140, hinge decks 150, inner and outer deck portions, and deck types.

**[0036]** A hinge deck 150 generally may refer to an end portion of deck 130 that may be raised or lowered into various positions (such as a slanted or flat position). In some embodiments, a hinge deck 150 may also refer to a “B” hinge deck of an autorack 110. Hinge deck 150 may be used to load vehicles into the loading positions of levels 120. According to various embodiments, hinge deck 150 may include a clear underside (e.g., a clearance region) over an end loading position of a lower level 120 (such as position A1 or position A5 of level 120a) where a roof of a vehicle being loaded into position A1 or position A5 may contact the underside of hinge deck 150 in the lowered position. A clearance region may include a slot in hinge deck 150, an increase in the arch of hinge deck 150, a stamped in “bubble” in hinge deck 150, and so on, as described below in more detail.

**[0037]** In general, system 100 increases the vertical clearance of one or more loading positions within autorack 110. According to various embodiments, system 100 may do so by providing a clearance region in one or more hinge decks 150. In some embodiments, position A1 and position A5 are each located on an end of the lowest deck 130 (e.g., “A” deck 130a). Draft gear housing of an autorack 110 may be located below position A1 and/or position A5. As a result, a vehicle being shipped on one of these loading positions may be on a slope above the draft gear housing of autorack 110 and below hinge decks 150, which may reduce the

amount of roof clearance for vehicles loaded in positions A1 and/or A5, especially for vehicles with GPS antennas.

**[0038]** To provide additional roof clearance in position A1, position A5, and/or any other loading position of autorack 110, system 100 may create a clearance region in hinge decks 150 directly above the loading positions for which additional vertical clearance is desired. Additionally, to increase the load capacity of autorack 110, system 100 may increase a height of position A1, position A5, or any other loading position.

**[0039]** Although FIGURES 1A and 1B illustrate system 100 as including one autorack 110, three levels 120, three decks 130, two slope decks 140, two hinge decks 150, and five positions, system 100 may include any number of autoracks 110, levels 120, decks 130, slope decks 140, hinge decks 150, positions, and other suitable components. For example, system 100 may comprise two levels 120 and two decks 130. Additionally, although particular examples of autoracks 110, levels 120, decks 130, slope decks 140, hinge decks 150, and positions have been described, the present disclosure contemplates any suitable autoracks 110, levels 120, decks 130, slope decks 140, hinge decks 150, and positions comprising any suitable components configured in any suitable manner, according to particular needs.

**[0040]** FIGURES 2A and 2B illustrate example areas of an autorack for which increased vertical clearance may be provided in accordance with particular embodiments. In general, system 100 increases the vertical clearance of one or more loading positions of autorack 110 by providing clearance regions in corresponding hinge decks 150. Examples of clearance regions may include a slot in hinge deck 150, a rectangular opening in hinge deck 150, an increase in the arch of hinge deck 150, a stamped in “bubble” in hinge deck 150, and so on, as described below in more detail. In certain embodiments, adding clearance regions in hinge decks 150 may result in additional roof clearance for vehicles in the loading positions directly below those hinge decks 150, increased load capacity of autorack 110, and may eliminate any losses caused from damaged roofs in those positions.

**[0041]** FIGURE 2A illustrates a perspective view of an example location for a clearance region in a deck of an autorack in accordance with particular embodiments. In general, a clearance region may be located in a center area 160 of an underside of a hinge deck 150. In certain embodiments, center area 160 may be approximately 3” inches to 6” inches wide. As illustrated, center area 160 may be located above a GPS antenna 170 of a vehicle 180 in, for example, loading position A1 or position A5. In certain embodiments, center area 160 may

be the centerline of the underside of a deck plate of hinge deck 150. In some embodiments, eliminating any structure (e.g., materials from a deck plate) in central area 160 may provide the greatest amount of clearance for a vehicle 180 comprising a GPS antenna 170.

**[0042]** FIGURE 2B illustrates a bottom view of an example clearance region formed in a hinge deck of a system for increasing vertical clearance in an autorack in accordance with particular embodiments. In general, a clearance region may be located on the underside of hinge deck 150 and may be in a center area 160 of hinge deck 150. In certain embodiments, center area 160 may be referred to as a “picture frame” 190, which may be the center area of a deck plate 155 of hinge deck 150. Center area 160 may be approximately 1’ foot to 6’ feet wide and approximately 6’ feet to 12’ feet long, in some embodiments. In certain embodiments, center area 160 may be approximately 2.8’ feet wide and 9.25’ feet wide. The present disclosure contemplates center area 160 being any suitable width and length. According to some embodiments, removing center area 160 from deck plate 155 or otherwise adding a clearance region in picture frame 190 of deck plate 155 may provide the greatest amount of clearance for a vehicle 180 comprising a GPS antenna 170.

**[0043]** In general, system 100 may include a clearance region in center area 160. To provide a clearance region, system 100 may modify a center area 160 of a deck plate 155. Examples of modifying center area 160 may include: (1) removing the material located in center area 160; (2) adding an upwards arch in center area 160; (3) raising center area 160 up 1” inch or more to form a flat and/or corrugated raised material; (4) using a trampoline-like material or other flexible material in center area 160 that will give if GPS antenna 170 contacts the underside of center area 160 of hinge deck 150; (5) pressing center area 160 up to form a dome or bubble; (6) modifying center area 160 in any other suitable manner; or (7) any combination of the preceding. It will be understood that system 100 may comprise any type of clearance region and any number and combination of clearance regions. Moreover, although particular examples of hinge deck 150 and center area 160 have been described, the present disclosure contemplates any suitable hinge deck 150 and center area 160 comprising any suitable components configured in any suitable manner, according to particular needs.

**[0044]** FIGURES 3A through 3D illustrate examples of a clearance region of a hinge deck in accordance with particular embodiments. In particular, FIGURE 3A illustrates a top view of an example clearance region of a hinge deck of a system for increasing vertical clearance in an autorack. A clearance region 200 generally includes a slot 210. A slot 210

may refer to a slot-shaped opening in a center area 160 of a hinge deck 150. For example, a slot 210 may be cut in center area 160 of deck plate 155 of a hinge deck 150 through the surface of hinge deck 150 to form clearance region 200. As a result, slot 210 may provide clearance for a GPS antenna 170. In certain embodiments slot 210 may be 3" to 6" wide. In alternative embodiments, slot 210 may be wider or narrower, for example, to take into account other vehicles not being loaded on center.

**[0045]** FIGURES 3B through 3D illustrate side views of an example clearance region of a hinge deck of a system for increasing vertical clearance in an autorack, an example clearance region with reinforcements formed in a deck of a system for increasing vertical clearance in an autorack, and an example hinge deck with a cover disposed over at least a portion of a clearance region, respectively, in accordance with particular embodiments. Clearance region 200 may refer to a slot 210 of a hinge deck 150. According to various embodiments, edges 220 of slot 210 may be reinforced with steel comings 230 (or any other suitable material). As illustrated in FIGURE 3C, steel comings 230 may extend above hinge deck 150 to provide additional strength, as well as to keep water from draining and debris from falling through slot 210.

**[0046]** In certain embodiments, hinge deck 150 may include a cover 240 over slot 210, as illustrated in FIGURE 3D. Cover 240 may comprise a molded rubber or elastomer material. Cover 240 may be flat or dome shaped. According to some embodiments, cover 240 may provide an inch or more clearance for a GPS antenna 170 while also protecting a corresponding vehicle in the below loading position (such as position A1 of level 120a) from debris, snow and leaking fluids from an above level 120 (such as level 120b, including hinge deck 150).

**[0047]** Cover 240 may also include a lip or C-shaped channel around its edges to be pressed into slot 210 to retain cover 240 on hinge deck 150, in certain embodiments. A rubber or elastomer cover 240 may prevent vehicles loaded and driven upon the top of hinge deck 150 from underside damage. In certain embodiments, a rubber or elastomer cover 240 may have "NO STEP" molded into it and may be made in red or any other color or combination of colors. In some embodiments, system 100 may retrofit clearance region 200 to an existing hinge deck 150 (e.g., to a hinge deck 150 after fabrication). For example, slot 210 may be cut into a centerline of hinge deck 150 and a rubber or elastomer cover 240 may be retrofitted to cover slot 210 of existing hinge deck 150 in the field or a in a shop.

**[0048]** Various embodiments may include a steel cover 240. A steel cover 240 may comprise a C-channel, inverted angle, or fabricated metal that may cover slot 210 of hinge deck 150. In some embodiments, additional structural strength may be provided by welding steel cover 240 to the top of hinge deck 150. In certain embodiments, steel cover 240 may be retrofitted to hinge deck 150. For example, steel cover 240 may be welded to an existing hinge deck 150 prior to cutting slot 210 (in the field or in a shop on existing autoracks 240). By doing so, warping may be prevented and a good fit may be achieved. A cover 240 for slot 210 may also be fastened to deck plate 155 or any other component of hinge deck 150.

**[0049]** In certain embodiments, clearance region 200 may be a slot 210 (or any other type of clearance region 200) formed by (1) bending the material of center area 160 in a press-break (e.g., raising the flat section of hinge deck 150 in the “picture frame” (or “window frame”) area and welding it to the structure) or (2) pressing the material of center area 160 in a die (e.g., deforming the flat section of hinge deck 150 in the “picture frame” area to push the section upwards for additional roof clearance in the below loading position). In such embodiments, center area 160 may be pressed, bent, and/or stamped into a certain shape (such as a bubble, dome, top hat, or other raised shape) to form slot 210 of hinge deck 150. For example, a “bubble” may be stamped in center area 160 to create a clearance area 200.

**[0050]** Slot 210 generally may be formed at any stage of fabrication or after fabrication of hinge deck 150. For example, if a deck plate 155 is fabricated by welding two or more sheets of metal together, a cut out for a slot 210 may be made to the sheets of metal before the sheets of metal are seam welded together. As another example, slot 210 may be cut after the sheets of metal are seam welded together but before fabrication of hinge deck 150. As yet another example, if a deck plate 155 includes one sheet of metal, a cut out for a slot 210 may be made to the sheet of metal before a corresponding hinge deck 150 is fabricated. As a further example, slot 210 may be cut after hinge deck 155 is fabricated (e.g., slot 210 may be added during the final fabrication of a new hinge deck 150 or slot 210 may be added to an existing hinge deck 150 (e.g., retrofitted)). The present disclosure contemplates slot 210 being added to hinge deck 150 in any suitable manner at any stage of fabrication or at any time after fabrication of hinge deck 150.

**[0051]** In some embodiments, in addition to or alternatively, the arch of hinge deck 150 may be increased (e.g., arched higher) to obtain the additional clearance in center areas 160 of new hinge decks 150 during fabrication or on existing hinge decks 150 after fabrication.

**[0052]** Clearance regions 200 formed in hinge decks 150 may allow taller vehicles 180 to be loaded on “A” deck 130a loading positions, such as position A1 and/or position A5. Clearance regions 200 may also increase the number of vehicles 180 that may be loaded on “A” deck 130a. Further, clearance regions 200 may increase bumper to bumper clearances of vehicles 180 loaded on “A” deck 130a. Although the present disclosure describes clearance regions 200 as increasing vertical clearances in “A” deck 130a positions A1 and A5, the present disclosure contemplates system 100 increasing vertical clearances in loading positions of any level 120 and deck 130.

**[0053]** Modification, additions, or omissions may be made to clearance region 200. In addition, although particular examples of clearance region 200 and hinge deck 150 have been described, this disclosure contemplates any suitable clearance region 200 and hinge deck 150 comprising any suitable components configured in any suitable manner, according to particular needs. Moreover, clearance region 200, hinge deck 150, and any components thereof, may be separate from or integral to any component of FIGURES 3A through 3D.

**[0054]** FIGURES 4A through 4E illustrate another example clearance region formed in a hinge deck in accordance with particular embodiments. In general, a hinge deck 150 of system 100 includes a clearance region, such as a clearance region 300, located in a center area 160 of a deck plate 155 to increase a vertical clearance of a loading position of autorack 110. As described above, hinge deck 150 may be located above an end loading position (such as position A1 or position A5).

**[0055]** FIGURES 4A and 4B illustrate a perspective view and top view, respectively, of an example clearance region 300 formed in a hinge deck 150 of a system for increasing vertical clearance in an autorack in accordance with particular embodiments. Hinge deck 150 may include clearance region 300. Clearance region 300 may be formed in deck plate 155 by cutting a rectangular opening 310 (or other suitable shape, such as a slot 210) in center area 160 of deck plate 155. Rectangular opening 310 may provide clearance for GPS antenna 170 of vehicle 180 located in, for example, position A1 or position A5 of autorack 110. Rectangular opening 310 may be 1’ foot to 6’ feet wide. In certain embodiments, rectangular opening 310 may be approximately 2’ feet to 3’ feet wide. In alternative embodiments, rectangular opening 310 may be wider or narrower, for example, to take into account other vehicles not being loaded on center.

**[0056]** As illustrated, edges 320 of rectangular opening 310 may be reinforced with steel comings 330 (or any other suitable material). According to some embodiments, steel comings 330 may extend above hinge deck 150 to provide additional strength, as well as to keep water from draining and debris from falling through rectangular opening 310.

**[0057]** In certain embodiments, hinge deck 150 may include a cover 340 over rectangular opening 310 and/or steel comings 330. Cover 340 may be set at various clearance heights. Cover 340 may comprise a molded rubber or elastomer material. A rubber or elastomer cover 340 may prevent vehicles loaded onto and/or driven upon the top of hinge deck 150 from underside damage. In certain embodiments, a rubber or elastomer cover 240 may have "NO STEP" molded into it and may be red or any other suitable color or combination of colors. According to various embodiments, a cover 340 may comprise steel. A steel cover 340 may be made from a C-channel, inverted angle, or fabricated metal to cover rectangular opening 310 in hinge deck 150.

**[0058]** As illustrated by FIGURE 4B, hinge deck 150 may also include curb plates 345, hinges 350, tire guides 355, socket and cones 360, spring supports 365, bridge plates 370, stiffeners 375, hinge pins 380, hinge supports 385, and deck reinforcements 390. The present disclosure contemplates hinge deck 150 comprising any number and any type of components.

**[0059]** FIGURES 4C and 4D illustrate a perspective view and an end view, respectively, of another example hinge deck with a cover disposed over at least a portion of a clearance region in accordance with particular embodiments. As described with respect to FIGURES 4A and 4B, a clearance region 300 may include a cover 340 over a rectangular opening 310.

**[0060]** Cover 340 may comprise a molded rubber, an elastomer material, a flat steel plate, an arched steel plate, a trap door, a hinged door, a slide-in plate (that may be easily removed), a mesh material, a dome, and so on. In certain embodiments, cover 340 may refer to center area 160 of deck plate 155. For example, center area 160 of deck plate 155 may be raised an inch or more above deck plate 155 to create rectangular opening 310 (in addition to clearance region 300), thereby providing an inch or more of additional clearance in the below loading position (e.g., position A1 or position A5). In some embodiments, cover 340 may be set at various clearance heights. As another example, cover 340 may be arched upward to form clearance region 300 and to provide additional vertical clearance in the below loading position.

**[0061]** As illustrated by FIGURES 4C and 4D, a cover 340 may be fastened to a top portion of hinge deck 150 and may cover clearance region 300. For example, cover 340 may be welded to the inside of steel comings 330. As another example, cover 340 may be welded to the top of and/or around the top of steel comings 330. As a further example, cover 340 may be welded to tire guides 355. In some embodiments, additional structural strength may be provided by welding steel cover 340 to such a top portion of hinge deck 150. In certain embodiments, cover 340 may be secured and/or welded to the top of closure plates 395.

**[0062]** Cover 340 may provide various advantages to system 100, such as an inch or more clearance for a GPS antenna 170 of a vehicle 180 located in, for example, a below loading position (such as positions A1 or A5), as well as protecting the particular vehicle 180 from debris, snow, and other fluids capable of leaking from loading positions of higher levels 120 (such as level 120b or level 120c). As another example, cover 340 may include a lip or C-shaped channel around edges 320 that may press into or squeeze around rectangular opening 310, thereby retaining cover 340 on hinge deck 150, in certain embodiments.

**[0063]** Rectangular openings 310 and covers 340 may be retrofitted to hinge decks 150 after fabrication to add clearance regions 300 to existing hinge decks 150. For example, a rectangular opening 310 may be cut in center area 160 of existing hinge deck 150. In such an example, a cover 340, such as a rubber, elastomer, or steel cover 340, may then be retrofitted to the existing hinge deck 150. Such retrofits may be done in the field or in a shop. In certain embodiments, a steel cover 340 may be retrofitted by welding steel cover 340 to hinge deck 150 of an existing autorack 110 prior to cutting rectangular opening 310 in, for example, center area 160. Doing so may result in a good fit and prevent warping.

**[0064]** In certain embodiments, clearance region 300 may be formed from a deck plate 155. For example, clearance region 300 may be formed by (1) bending the material of center area 160 of deck plate 155 in a press-break and/or (2) pressing the material of center area 160 of deck plate 155 in a die. Doing so may result in a bubble, dome, top hat, or other raised shape in an area between tire guides 355 of hinge deck 150, which may increase an overall clearance of autorack 110.

**[0065]** Clearance region 300 (in addition to rectangular opening 310) generally may be formed at any stage of fabrication or after fabrication of hinge deck 150. For example, if a deck plate 155 is fabricated by welding two or more sheets of metal together, a cut out for a rectangular opening 310 may be made to the sheets of metal before the sheets of metal are

seam welded together. As another example, rectangular opening 310 may be cut after the sheets of metal are seam welded together but before fabrication of hinge deck 150. As yet another example, if a deck plate 155 includes one sheet of metal, a cut out for a rectangular opening 310 may be made to the sheet of metal before a corresponding hinge deck 150 is fabricated. As a further example, rectangular opening 310 may be cut after hinge deck 155 is fabricated (e.g., rectangular opening 310 may be added during the final fabrication of a new hinge deck 150 or rectangular opening 310 may be added to an existing hinge deck 150 (e.g., retrofitted)). The present disclosure contemplates rectangular opening 310 being added to hinge deck 150 in any suitable manner at any stage of fabrication or at any time after fabrication of hinge deck 150.

**[0066]** In some embodiments, in addition to or alternatively, deck plate 155 and/or cover 340 may be arched in an upward direction to obtain additional clearance in clearance region 300. This may be done to new hinge decks 150 during fabrication or may be done to existing hinge decks 150 in the field or in a shop.

**[0067]** By increasing the vertical clearance of loading positions located under hinge decks 150, taller vehicles may be loaded onto level 120a, the number of vehicles loaded onto level 120a may be increased, and the bumper to bumper clearance on level 120a may be increased. Particularly, clearance regions 300 formed in hinge decks 150 may increase the height of loading positions directly below such hinge decks 150, and thus allow taller vehicles 180 to be loaded on, for example, “A” deck 130a loading positions A1 and/or A5. Accordingly, clearance regions 300 may increase the number of vehicles 180 that may be loaded on “A” deck 130a. Further, clearance regions 200 may increase bumper to bumper clearances of vehicles 180 loaded on “A” deck 130a as vehicles 180 loaded in positions A1 and A5 may be secured farther up corresponding slope decks 140. Although the present disclosure describes clearance regions 300 as increasing vertical clearances in “A” deck 130a positions A1 and A5, the present disclosure contemplates system 100 increasing vertical clearances in loading positions of any level 120 and deck 130.

**[0068]** FIGURE 4E illustrates a perspective view of an example clearance region formed in a deck of a system for increasing vertical clearance in an autorack in accordance with particular embodiments. In general, a clearance region 300 may be located in a center area (such as a center area 160 of FIGURES 2A and 2B) of an underside of a deck plate 155 of a hinge deck 150 to increase the vertical clearance of a loading position. According to the

illustrated embodiment, clearance region 300 may be located above a GPS antenna 170 of a vehicle 180 in, for example, loading position A1 or A5. Thus, clearance region 300 may provide additional roof clearance for vehicles 180 with roof-mounted GPS antennas 170.

**[0069]** As described above with respect to FIGURES 4A through 4D, clearance region 300 may comprise a rectangular opening 310 proximate the center line of hinge deck 150 (and deck plate 155). In general, the underside portion of hinge deck 150 at rectangular opening 310 of clearance region 300 is higher than the other underside portions of hinge deck 150 not at the clearance region.

**[0070]** Although particular examples of clearance region 300 and hinge deck 150 have been described, this disclosure contemplates any suitable clearance region 300 and hinge deck 150 comprising any suitable components configured in any suitable manner, according to particular needs. Moreover, clearance region 300, hinge deck 150, and any components thereof, may be separate from or integral to any component of FIGURES 4A through 4E.

**[0071]** FIGURE 5 illustrates an end view of an example hinge deck with a clearance region in accordance with particular embodiments. Similar to FIGURES 4A through 4E, FIGURE 5 includes a hinge deck 150, a deck plate 155, and a clearance region 300, as well as any other component described above with respect to FIGURES 1 through 4E.

**[0072]** In the illustrated embodiment, clearance region 300 may be formed by cutting a rectangular opening 310 in deck plate 155 and securing a cover 340 at a certain clearance height (e.g., a certain height above the height of deck plate 155).

**[0073]** Cutting a rectangular opening 310 may include removing, from deck plate 155, any material located in center area 160 and between tire guides 355. In certain embodiments, the removed material may be used to form cover 340. For example, the removed material may be fastened on top of steel comings 330 and/or tire guides 355.

**[0074]** According to various embodiments, a cover 340 may be fitted on top of reinforcements of hinge deck 150. For example, cover 340 may be secured to steel comings 330 and/or tire guides 355. Cover 340 may be secured either before or after cutting a rectangular opening 310 in deck plate 155. Cover 340 may be raised approximately 1" inch to 3" inches higher than deck plate 155. Further, cover 340 may protect a GPS antenna 170 of a vehicle 180 being loaded in position A1 or position A5.

**[0075]** As illustrated, a clearance region 300 of hinge deck 150 may be formed into various shapes, such as a "top hat," to increase the height of position A1 and/or position A5.

Although FIGURE 5 illustrates particular examples of clearance region 300, rectangular opening 310, steel comings 330, cover 340, hinge deck 150, and deck plate 155, this disclosure contemplates any suitable clearance region 300, rectangular opening 310, steel comings 330, cover 340, hinge deck 150, and deck plate 155 comprising any suitable components configured in any suitable manner, according to particular needs. Moreover, clearance region 300, rectangular opening 310, steel comings 330, cover 340, hinge deck 150, deck plate 155, and any components thereof, may be separate from or integral to any component of the present disclosure.

**[0076]** FIGURE 6 illustrates an end view of another example hinge deck with a clearance region in accordance with particular embodiments. Similar to FIGURES 4A through 5, FIGURE 6 may include a hinge deck 150, a deck plate 155, and a clearance region 300, as well as any other component described above with respect to FIGURES 1 through 5. In the illustrated embodiment, clearance region 300 may be formed by cutting a rectangular opening 310 in deck plate 155 and securing a cover 340 a certain height above deck plate 155. It shall be understood that cover 340 may be fitted to hinge deck 150 at any suitable height to achieve various clearance heights.

**[0077]** To provide clearance region 300, system 100 may remove, from deck plate 155, material located in center area 160 and between tire guides 355 by cutting a rectangular opening 310 through deck plate 155. Although clearance region 300 is described as including a rectangular opening 310, the present disclosure contemplates clearance region 300 having any number and any type of openings and/or clearance regions.

**[0078]** In certain embodiments, the removed material may be used to form cover 340. For example, the removed material may be fastened inside of steel comings 330 or tire guides 355.

**[0079]** In the illustrated embodiment, cover 340 may be fitted above and/or on top of closure plates 395 and between tire guides 355. Once fitted, cover 340 may be welded (or otherwise fastened) to closure plates 395 and/or tire guides 355. In certain embodiments, a closure plate 395 may be used to close an opening due to the coping of the structure being joined at a tire guide 355 due to the tire guide radius.

**[0080]** According to various embodiments, a cover 340 may be fitted to the inside of reinforcements of hinge deck 150. For example, cover 340 may be welded to the inside of steel comings 330 and/or tire guides 355. Cover 340 may be secured either before or after

cutting a rectangular opening 310 in deck plate 155. Cover 340 may be raised approximately 1" inch to 3" inches higher than deck plate 155 and may be welded at a height lower than tire guides 155, in certain embodiments. Cover 340 may protect a GPS antenna 170 of a vehicle 180 being loaded in position A1 or position A5.

**[0081]** As illustrated, a clearance region 300 of hinge deck 150 may be formed into various shapes, such as a "top hat," to increase the height of a below loading position such as position A1 or position A5. Further, clearance region 300 may be set at various clearance heights to increase a vertical clearance of position A1 or position A5. In certain embodiments, using a "top hat" design to provide clearance region 300 may protect any placement of GPS antenna 170 on vehicle 180. For example, if GPS antenna 170 is placed on the roof closer to the front of vehicle 180 or on the roof closer to a side of vehicle 180 (e.g., not located on a centerline), a "top hat" design will still provide clearance for GPS antenna 170.

**[0082]** Although FIGURE 6 illustrates particular examples of clearance region 300, rectangular opening 310, steel comings 330, cover 340, hinge deck 150, and deck plate 155, the present disclosure contemplates any suitable clearance region 300, rectangular opening 310, steel comings 330, cover 340, hinge deck 150, and deck plate 155 comprising any suitable components configured in any suitable manner, according to particular needs. Moreover, clearance region 300, rectangular opening 310, steel comings 330, cover 340, hinge deck 150, deck plate 155, and any components thereof, may be separate from or integral to any component of the present disclosure.

**[0083]** FIGURE 7 illustrates an example method 400 for increasing a vertical clearance of an autorack according to particular embodiments. The method may begin at step 402 where a vertical clearance of a loading position of autorack 110 may be increased. According to various embodiments, method 400 may increase the vertical clearance of a loading position by adding a clearance region 200 or a clearance region 300 to a hinge deck 150. Example clearance regions may include a raised flat (such as a raised rectangular flat), a slot, a bubble, a top hat, a rectangular opening, an arch, a mesh, a flexible material, any other suitable type of opening in hinge deck 150, any other suitable type of raised surface and/or material, or any combination of the preceding.

**[0084]** At step 404, a slot 210 or a rectangular opening 310 may be formed in a center area 160 of hinge deck 150. Center area 160 may refer to a centerline or a "picture frame"

region of a deck plate 155 associated with hinge plate 150. Method 400 may form slot 210 or rectangular opening 310 by cutting a slot, rectangle, or other suitable shape out of center area 160.

**[0085]** Edges 220 of slot 210 or edges 320 of rectangular opening 310 may be reinforced, at step 406. Method 400 may do so by welding steel comings 230 or steel comings 330 to, for example, edges 220 or edges 320, respectively.

**[0086]** At step 406, a cover 240 or cover 340 may be fitted to cover slot 210 or rectangular opening 310, respectively. Method 400 may do so by fastening cover 240 or cover 340 to reinforcements of hinge deck 150 or any other suitable component of hinge deck 150, as described above with respect to FIGURES 1 through 6.

**[0087]** After performing step 406, the method may end.

**[0088]** Some of the steps illustrated in FIGURE 7 may be combined, modified, or deleted where appropriate, and additional steps may also be added to the flowchart. Additionally, steps may be performed in any suitable order without departing from the scope of the disclosure.

**[0089]** Teachings of the present disclosure may be satisfactorily used to increase vertical clearance in autoracks. Modifications, additions, or omissions may be made to the systems described herein without departing from the scope of the present disclosure. The components may be integrated or separated. Moreover, the operations may be performed by more, fewer, or other components. Additionally, the operations may be performed using any suitable logic comprising software, hardware, and/or other logic. As used in this document, “each” refers to each member of a set or each member of a subset of a set.

**[0090]** Modifications, additions, or omissions may be made to the methods described herein without departing from the scope of the present disclosure. For example, the steps may be combined, modified, or deleted where appropriate, and additional steps may be added. Additionally, the steps may be performed in any suitable order without departing from the scope of the present disclosure.

**[0091]** Although embodiments of the present disclosure and their advantages have been described in detail, it should be understood that various changes, substitutions and alternations can be made herein without departing from the spirit and scope of the present disclosure as defined by the following claims. Moreover, although particular embodiments have been described herein, a myriad of changes, variations, alterations, transformations,

substitutions, and modifications may be suggested to one skilled in the art, and it is intended that the present disclosure encompass such changes, variations, alterations, transformations, substitutions, and modifications as fall within the scope of the appended claims. For example, although particular embodiments of the disclosure have been described with reference to a number of elements included in a system for increasing vertical clearance in autoracks, these elements may be combined, rearranged or positioned in order to accommodate particular storage requirements or needs. Various embodiments contemplate great flexibility in the system for increasing vertical clearance in autoracks and its components. Additionally, while some embodiments are described with respect to an autorack, particular embodiments may be used for any type of transport.

**CLAIMS**

1. A system comprising:  
an autorack comprising a plurality of decks;  
a first deck of the plurality of decks positioned beneath a second deck of the plurality of decks;  
the second deck comprising a clearance region proximate a center line of the second deck;  
wherein a first portion of an underside surface of the second deck at the clearance region is higher than a second portion of the underside surface of the second deck not at the clearance region.
2. The system of Claim 1, wherein the clearance region comprises a rectangular opening proximate the center line of the second deck.
3. The system of Claim 2, wherein the clearance region further comprises at least one reinforcing member, the at least one reinforcing member coupled to the second deck near an edge of the rectangular opening.
4. The system of Claim 3, wherein the top of the at least one reinforcing member is higher than at least a portion of a topside surface of the second deck.
5. The system of Claim 1, wherein the second deck further comprises at least one reinforcing member coupled to at least a portion of the clearance region, the at least one reinforcing member configured to reinforce the clearance region.
6. The system of Claim 1, further comprising a cover configured to be coupled to the second deck and disposed over at least a portion of the clearance region.
7. The system of Claim 6, wherein the cover comprises steel, mesh, rubber, or elastomer.

8. The system of Claim 1, wherein the clearance region comprises a slot proximate the center line of the second deck.

9. The system of Claim 1, wherein a first portion of a topside surface of the second deck at the clearance region is higher than a second portion of the topside surface of the second deck not at the clearance region.

10. The system of Claim 1, wherein at least a portion of the second deck is a hinge deck.

11. A method comprising:  
forming a clearance region proximate a center line of a first deck of an autorack, the first deck positioned above a second deck of the autorack;  
wherein a first portion of an underside surface of the first deck at the clearance region is higher than a second portion of the underside surface of the first deck not at the clearance region.

12. The method of Claim 11, wherein forming the clearance region proximate the center line of the first deck comprises creating an opening in the first deck proximate the center line of the first deck.

13. The method of Claim 12, wherein the opening is a rectangular opening.

14. The method of Claim 13, further comprising coupling at least one reinforcing member to the second deck near an edge of the rectangular opening.

15. The method of Claim 14, wherein the top of the reinforcing member is higher than at least a portion of a topside surface of the first deck.

16. The method of Claim 11, further comprising coupling at least one reinforcing member to at least a portion of the clearance region, the at least one reinforcing member configured to reinforce the clearance region.

17. The method of Claim 11, further comprising coupling a cover to a topside surface of the first deck such that the cover is disposed over at least a portion of the clearance region.

18. The method of Claim 17, wherein coupling the cover to the topside surface of the first deck comprises welding the cover to the topside surface of the first deck.

19. The method of Claim 11, wherein forming the clearance region proximate the center line of the first deck comprises cutting a slot in the first deck proximate the center line of the first deck.

20. The method of Claim 11, wherein the first deck is a pre-existing deck.

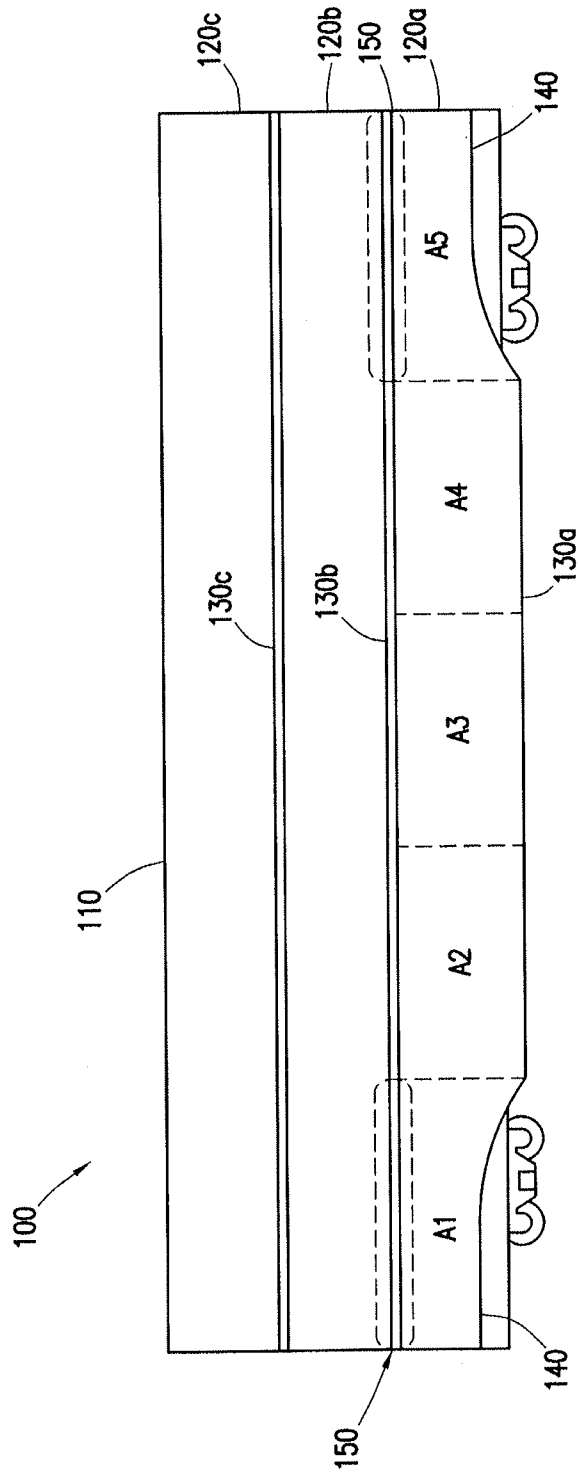

FIG. 1A

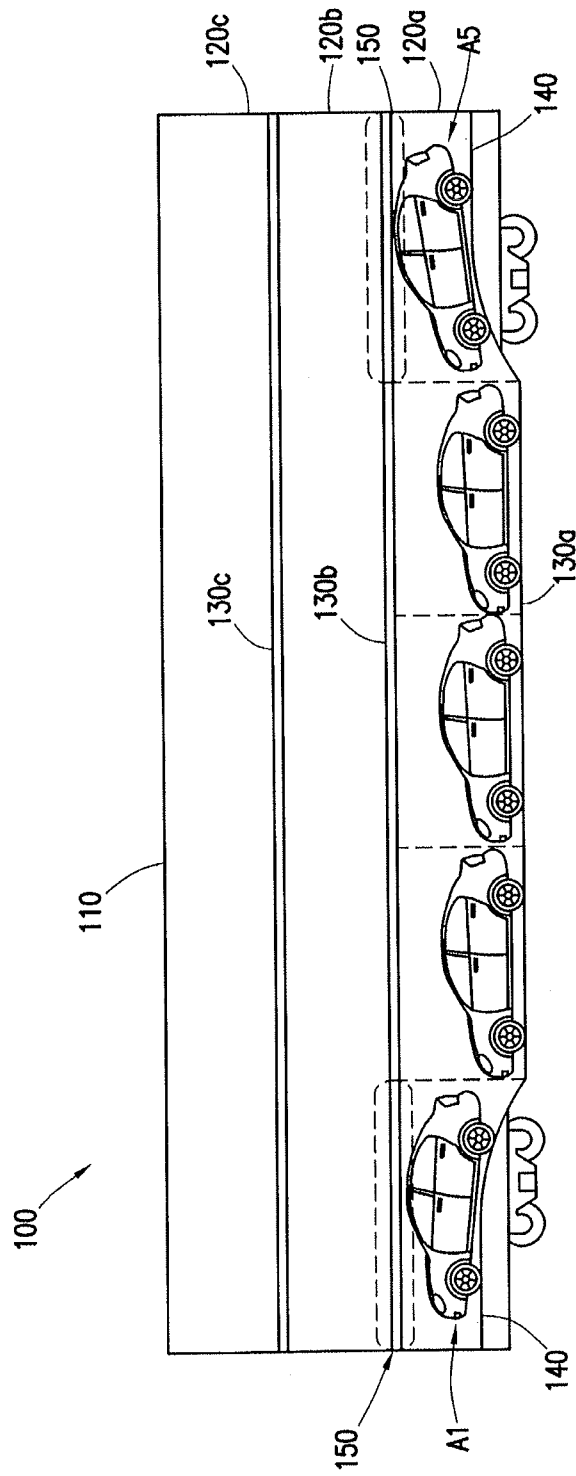

FIG. 1B

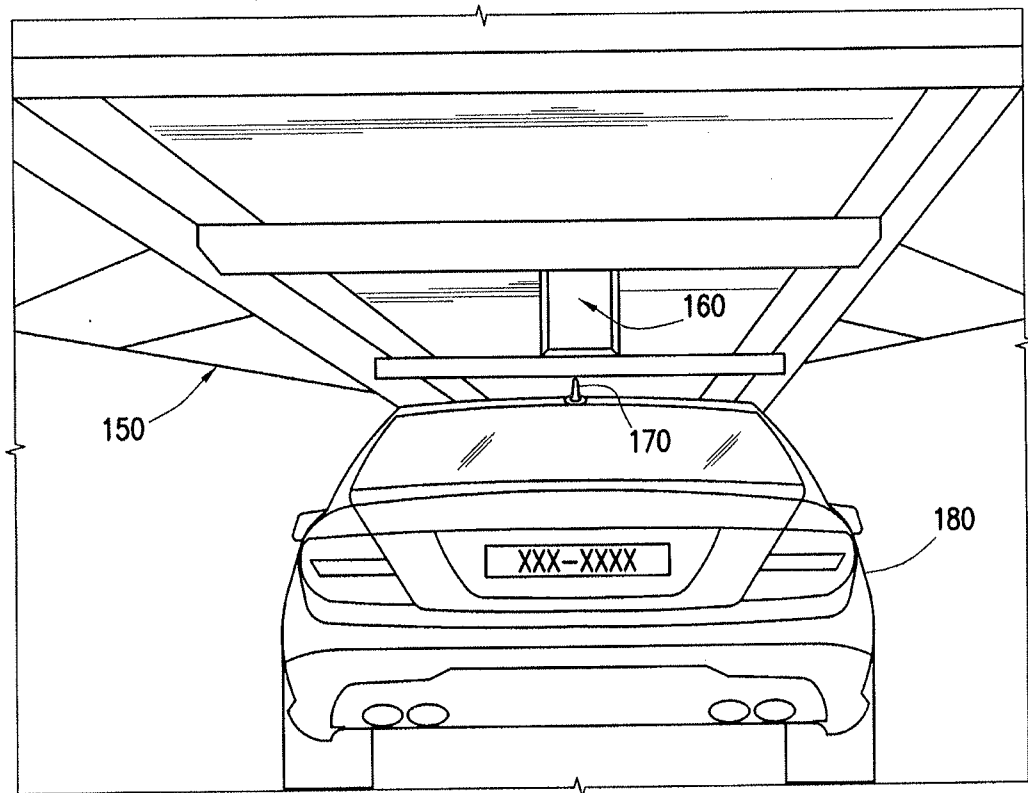

FIG. 2A

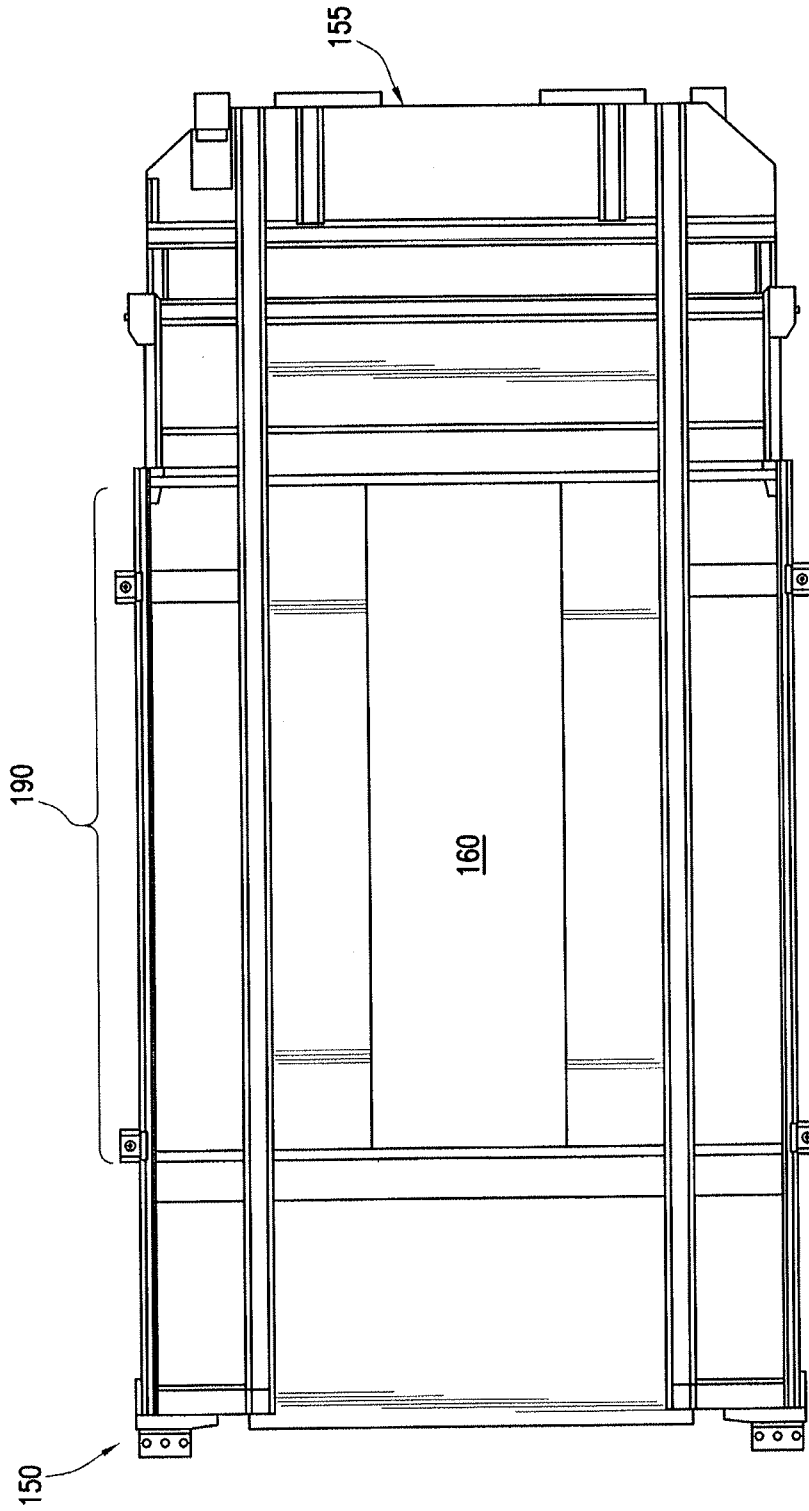

FIG. 2B

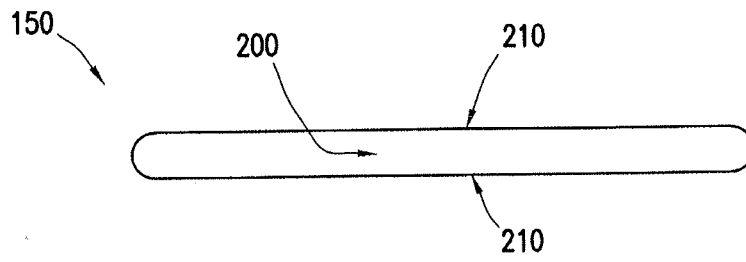

FIG. 3A

FIG. 3B

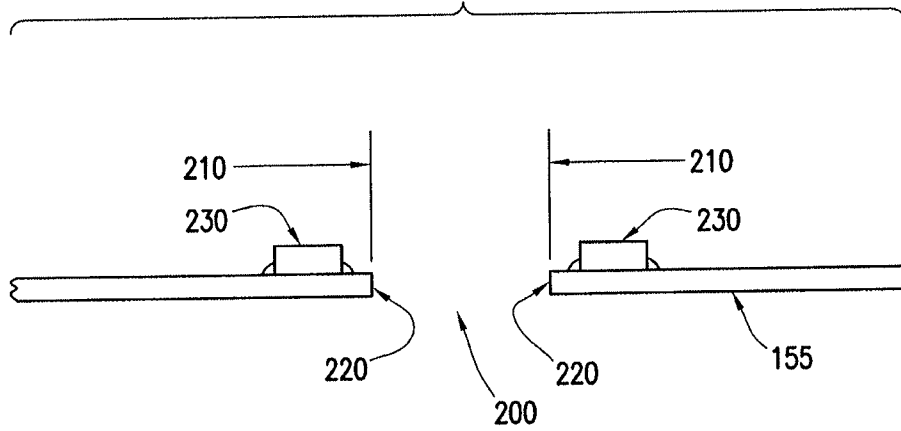

FIG. 3C

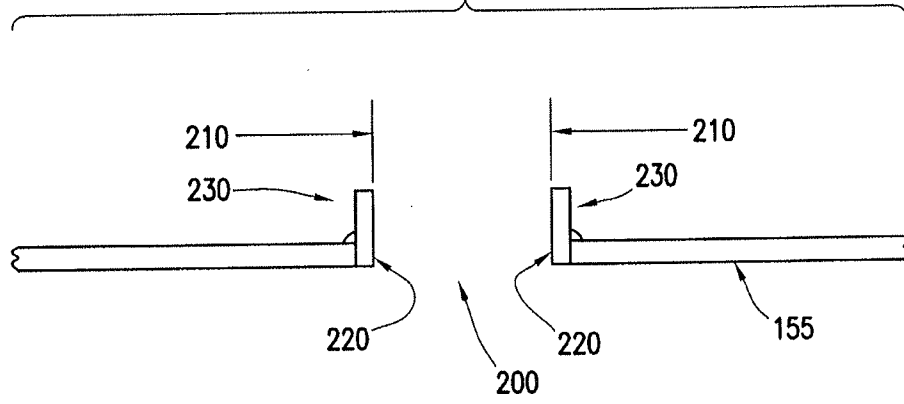
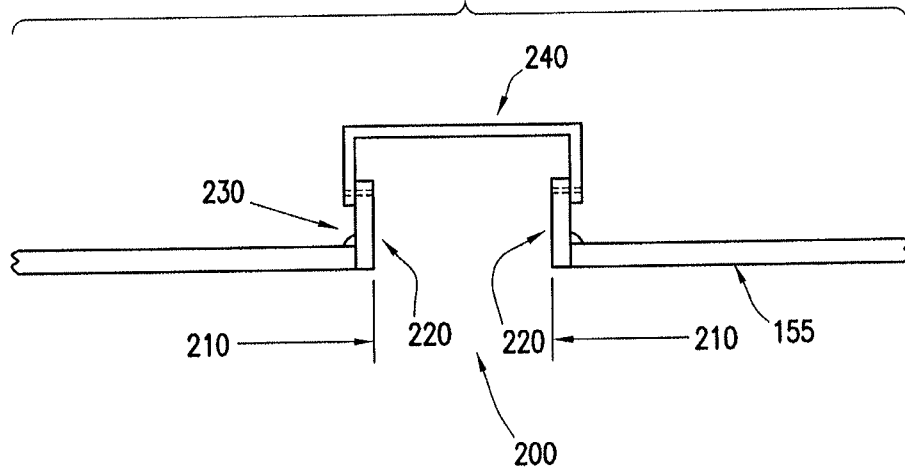

FIG. 3D



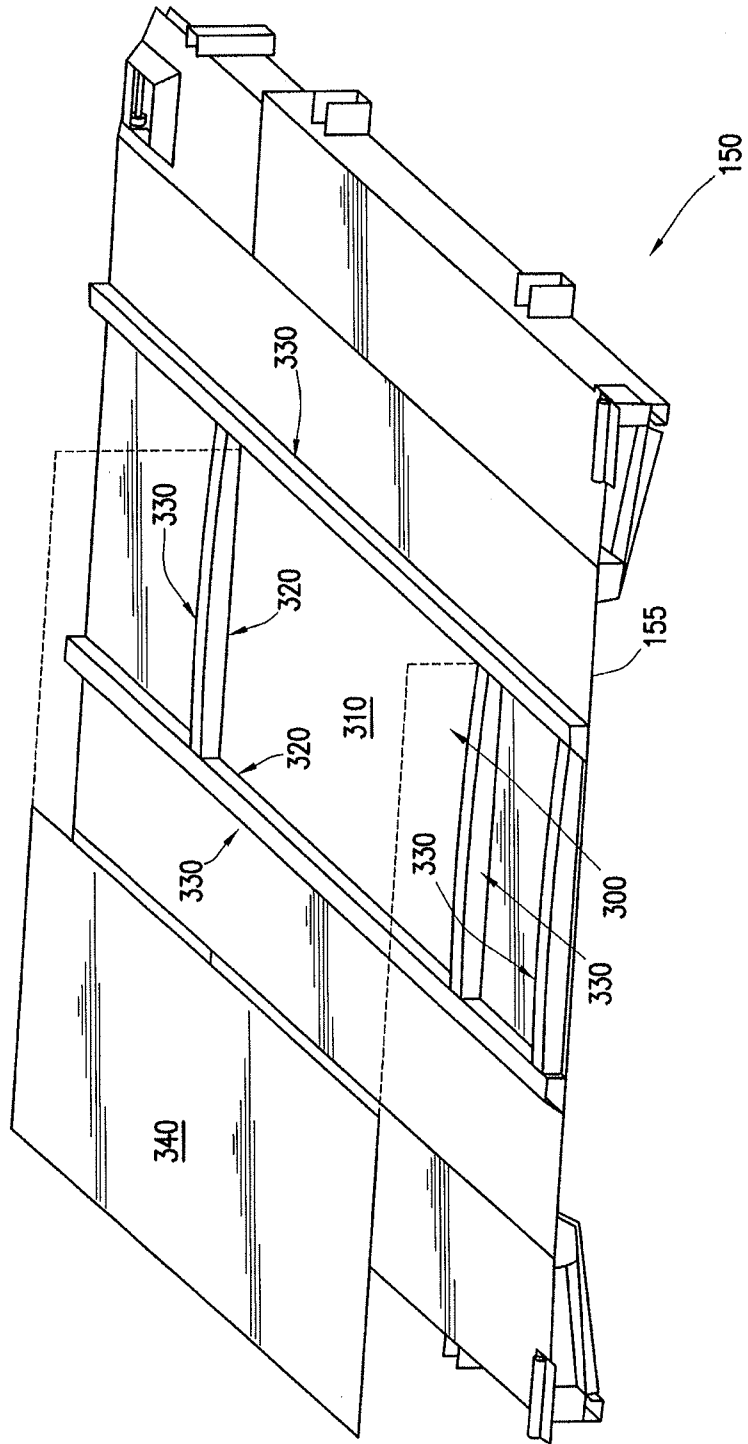

FIG. 4A

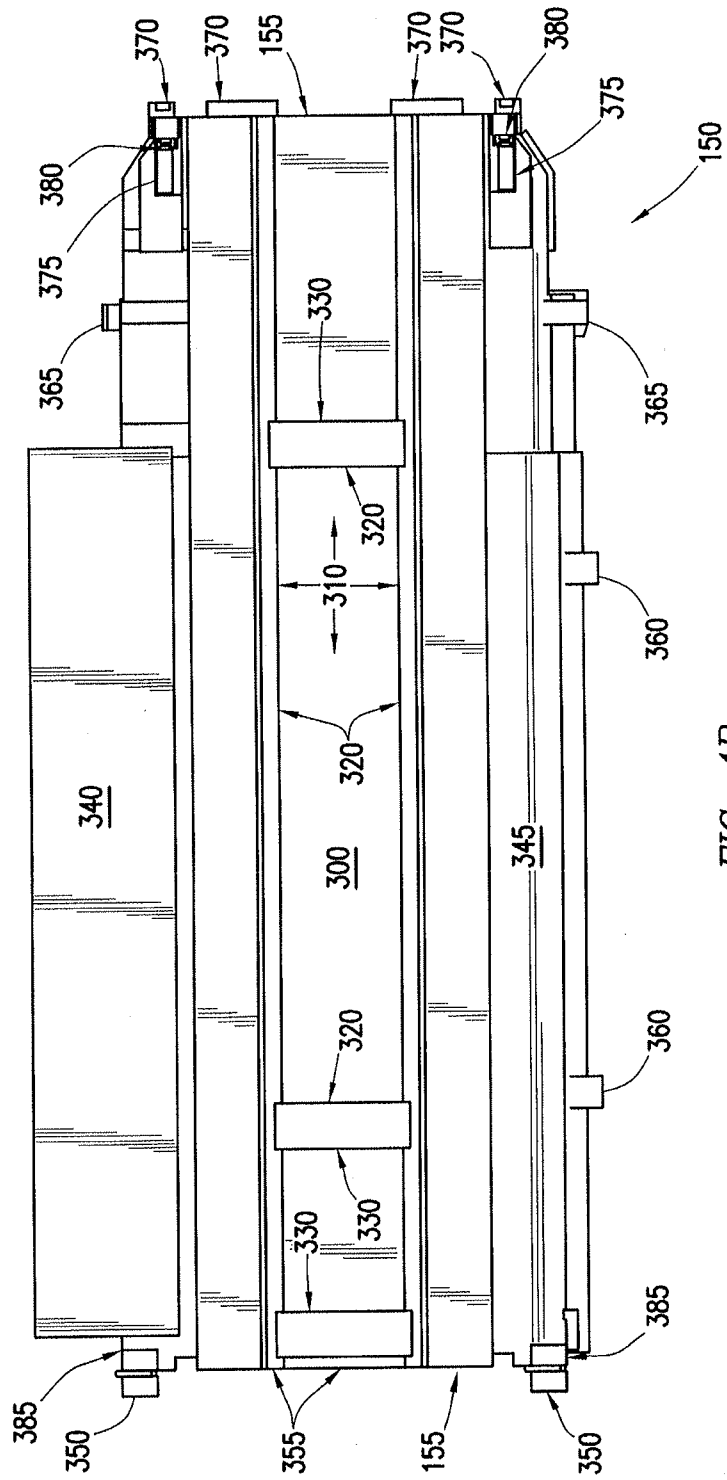

FIG. 4B

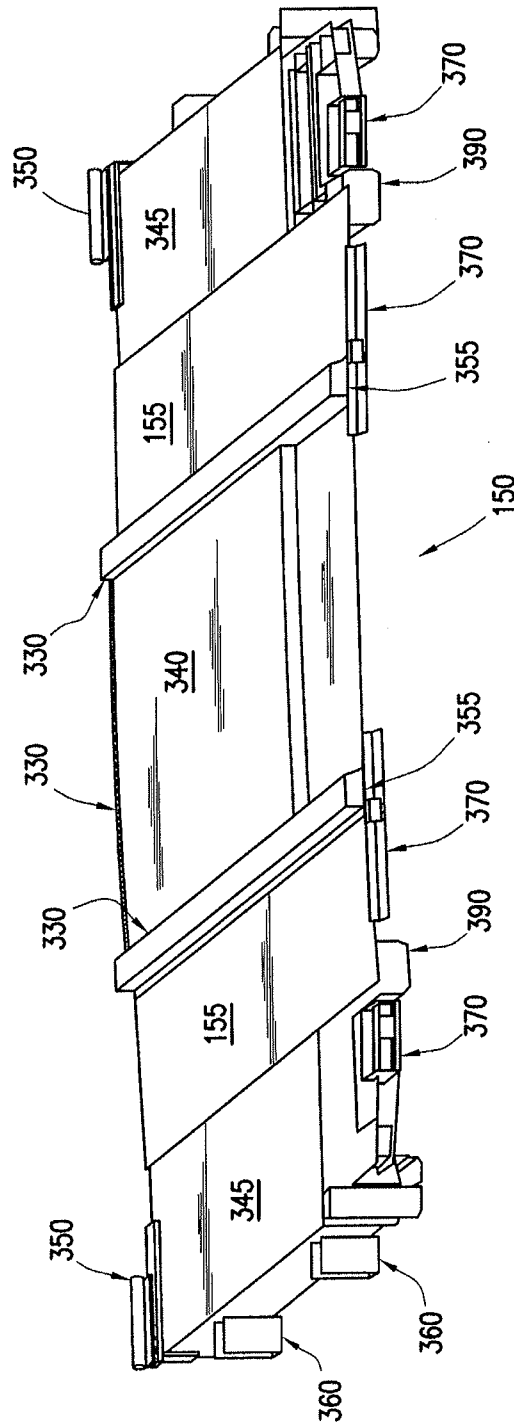

FIG. 4C

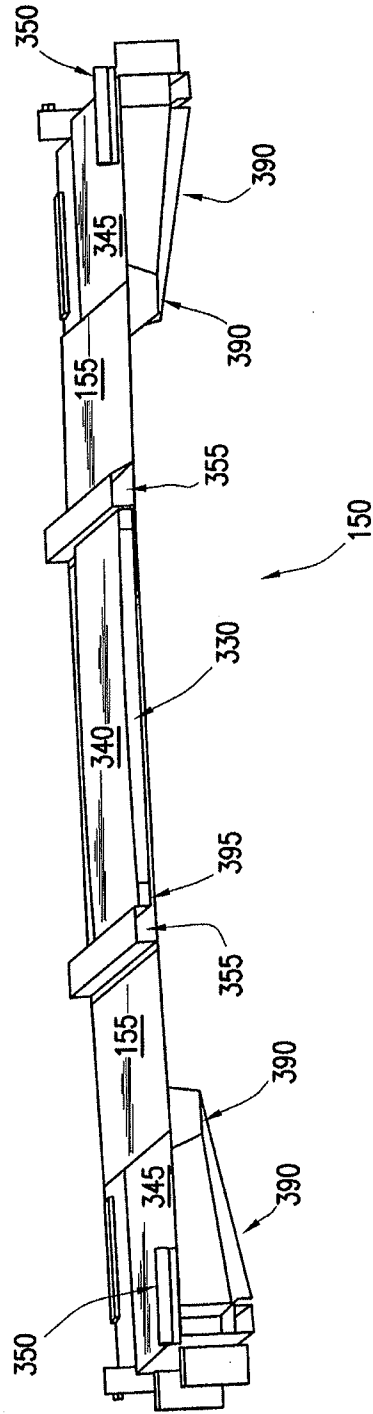

FIG. 4D

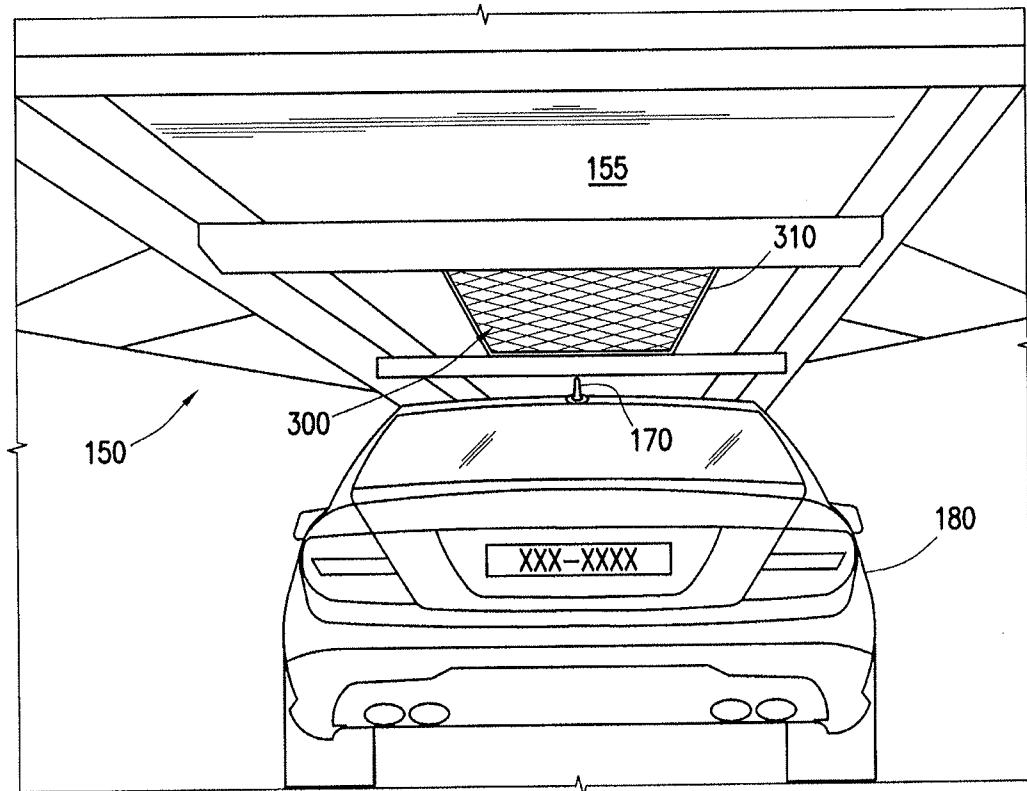

FIG. 4E

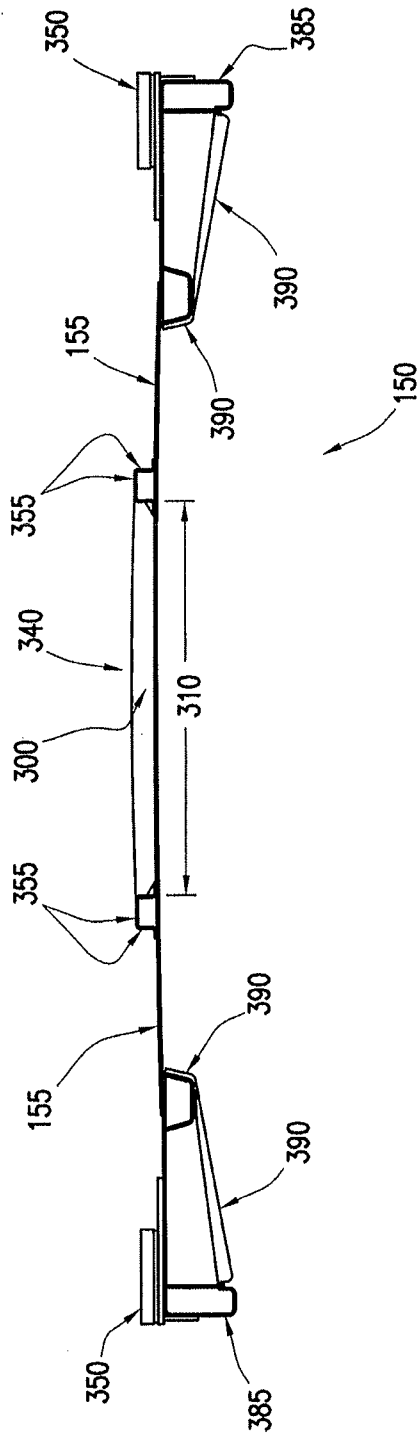

FIG. 5



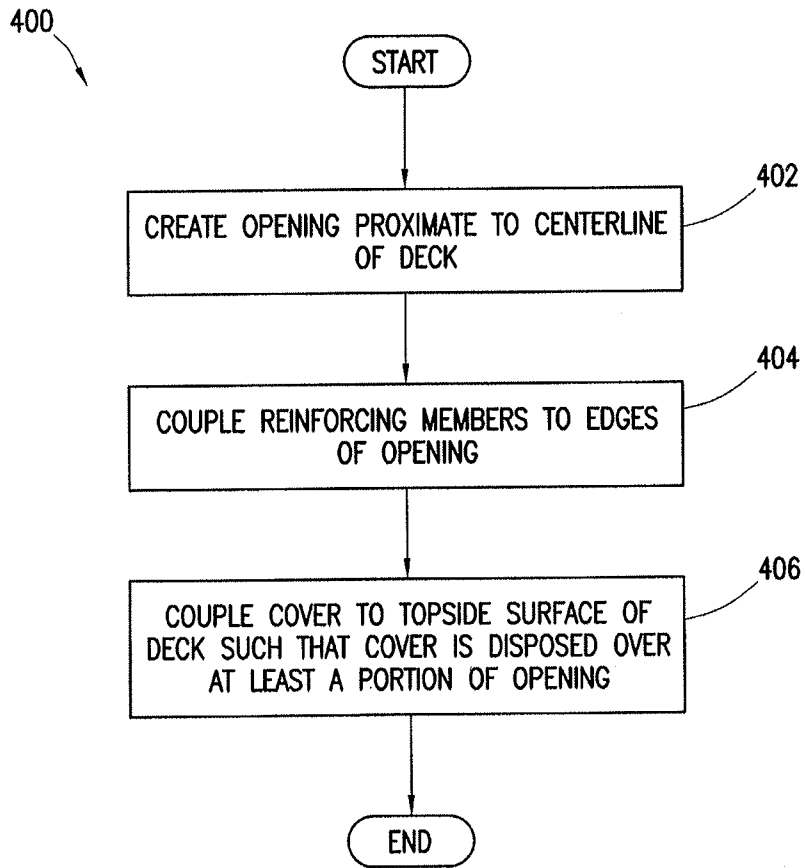

FIG. 7

# INTERNATIONAL SEARCH REPORT

International application No PCT/US2015/037908
---

<b>A. CLASSIFICATION OF SUBJECT MATTER</b> INV. B61D3/18                      B60P3/08 ADD.		
According to International Patent Classification (IPC) or to both national classification and IPC		
<b>B. FIELDS SEARCHED</b>		
Minimum documentation searched (classification system followed by classification symbols) B61D B60P		
Documentation searched other than minimum documentation to the extent that such documents are included in the fields searched		
Electronic data base consulted during the international search (name of data base and, where practicable, search terms used) EPO-Internal, PAJ, WPI Data		
<b>C. DOCUMENTS CONSIDERED TO BE RELEVANT</b>		
Category*	Citation of document, with indication, where appropriate, of the relevant passages	Relevant to claim No.
X	US 3 173 382 A (RYAN JAMES L) 16 March 1965 (1965-03-16) the whole document -----	1-20
X	US 2 659 318 A (STEINS CARLETON K ET AL) 17 November 1953 (1953-11-17) the whole document -----	1-5,8,9, 11-16, 19,20
X	LU 40 431 A1 (SOCIETE NATIONALE DES CHEMINS DE FER FRANCAIS [FR]) 25 September 1961 (1961-09-25) the whole document -----	1-5,8,9, 11-16, 19,20
X	FR 1 297 191 A (TRANSCAP) 29 June 1962 (1962-06-29) the whole document -----	1,2, 9-13,19, 20
<input type="checkbox"/> Further documents are listed in the continuation of Box C. <input checked="" type="checkbox"/> See patent family annex.		
* Special categories of cited documents :		
"A" document defining the general state of the art which is not considered to be of particular relevance	"T" later document published after the international filing date or priority date and not in conflict with the application but cited to understand the principle or theory underlying the invention	
"E" earlier application or patent but published on or after the international filing date	"X" document of particular relevance; the claimed invention cannot be considered novel or cannot be considered to involve an inventive step when the document is taken alone	
"L" document which may throw doubts on priority claim(s) or which is cited to establish the publication date of another citation or other special reason (as specified)	"Y" document of particular relevance; the claimed invention cannot be considered to involve an inventive step when the document is combined with one or more other such documents, such combination being obvious to a person skilled in the art	
"O" document referring to an oral disclosure, use, exhibition or other means	"&" document member of the same patent family	
"P" document published prior to the international filing date but later than the priority date claimed		
Date of the actual completion of the international search	Date of mailing of the international search report	
22 September 2015	30/09/2015	
Name and mailing address of the ISA/ European Patent Office, P.B. 5818 Patentlaan 2 NL - 2280 HV Rijswijk Tel. (+31-70) 340-2040, Fax: (+31-70) 340-3016	Authorized officer  Awad, Philippe	

# INTERNATIONAL SEARCH REPORT

Information on patent family members

International application No PCT/US2015/037908
---

Patent document cited in search report	Publication date	Patent family member(s)	Publication date
US 3173382	A	16-03-1965	NONE
US 2659318	A	17-11-1953	NONE
LU 40431	A1	25-09-1961	BE 606870 A4 01-12-1961
			CH 373069 A 15-11-1963
			DE 1184788 B 07-01-1965
			ES 269328 A1 01-03-1962
			FR 1272169 A 22-09-1961
			GB 967798 A 26-08-1964
			LU 40431 A1 25-09-1961
			NL 108461 C 22-09-2015
			NL 267968 A 22-09-2015
FR 1297191	A	29-06-1962	NONE