

(19) World Intellectual Property Organization
International Bureau



(43) International Publication Date
8 February 2007 (08.02.2007)

PCT

(10) International Publication Number
WO 2007/016083 A1

- (51) International Patent Classification:
A61F 2/00 (2006.01) A61B 17/04 (2006.01)
- (21) International Application Number:
PCT/US2006/028828
- (22) International Filing Date: 25 July 2006 (25.07.2006)
- (25) Filing Language: English
- (26) Publication Language: English
- (30) Priority Data:
60/702,704 26 July 2005 (26.07.2005) US
60/702,705 26 July 2005 (26.07.2005) US
60/702,700 26 July 2005 (26.07.2005) US

(74) Agent: SCHULTE, Daniel, C.; KAGAN BINDER, PLLC, Suite 200, Maple Island Building, 221 Main Street North, Stillwater, Minnesota 55082 (US).

(81) Designated States (unless otherwise indicated, for every kind of national protection available): AE, AG, AL, AM, AT, AU, AZ, BA, BB, BG, BR, BW, BY, BZ, CA, CH, CN, CO, CR, CU, CZ, DE, DK, DM, DZ, EC, EE, EG, ES, FI, GB, GD, GE, GH, GM, HN, HR, HU, ID, IL, IN, IS, JP, KE, KG, KM, KN, KP, KR, KZ, LA, LC, LK, LR, LS, LT, LU, LV, LY, MA, MD, MG, MK, MN, MW, MX, MZ, NA, NG, NI, NO, NZ, OM, PG, PH, PL, PT, RO, RS, RU, SC, SD, SE, SG, SK, SL, SM, SY, TJ, TM, TN, TR, TT, TZ, UA, UG, US, UZ, VC, VN, ZA, ZM, ZW.

(84) Designated States (unless otherwise indicated, for every kind of regional protection available): ARIPO (BW, GH, GM, KE, LS, MW, MZ, NA, SD, SL, SZ, TZ, UG, ZM, ZW), Eurasian (AM, AZ, BY, KG, KZ, MD, RU, TJ, TM), European (AT, BE, BG, CH, CY, CZ, DE, DK, EE, ES, FI, FR, GB, GR, HU, IE, IS, IT, LT, LU, LV, MC, NL, PL, PT, RO, SE, SI, SK, TR), OAPI (BF, BJ, CF, CG, CI, CM, GA, GN, GQ, GW, ML, MR, NE, SN, TD, TG).

(71) Applicant (for all designated States except US): AMS RESEARCH CORPORATION [US/US]; 10700 Bren Road West, Minnetonka, Minnesota 55343 (US).

(72) Inventors; and

(75) Inventors/Applicants (for US only): DAVILA, Guillermo, Wiley [US/US]; 2580 Southeast 8th Street, Pompano Beach, Florida 33062 (US). COX, James, E. [US/US]; 6851 County Road 101 North, Corcoran, Minnesota 55340 (US). ANDERSON, Kimberly, A. [US/US]; 4338 Jessica Court, Eagan, Minnesota 55123 (US).

Published:
— with international search report

For two-letter codes and other abbreviations, refer to the "Guidance Notes on Codes and Abbreviations" appearing at the beginning of each regular issue of the PCT Gazette.

(54) Title: METHODS AND SYSTEMS FOR TREATMENT OF PROLAPSE

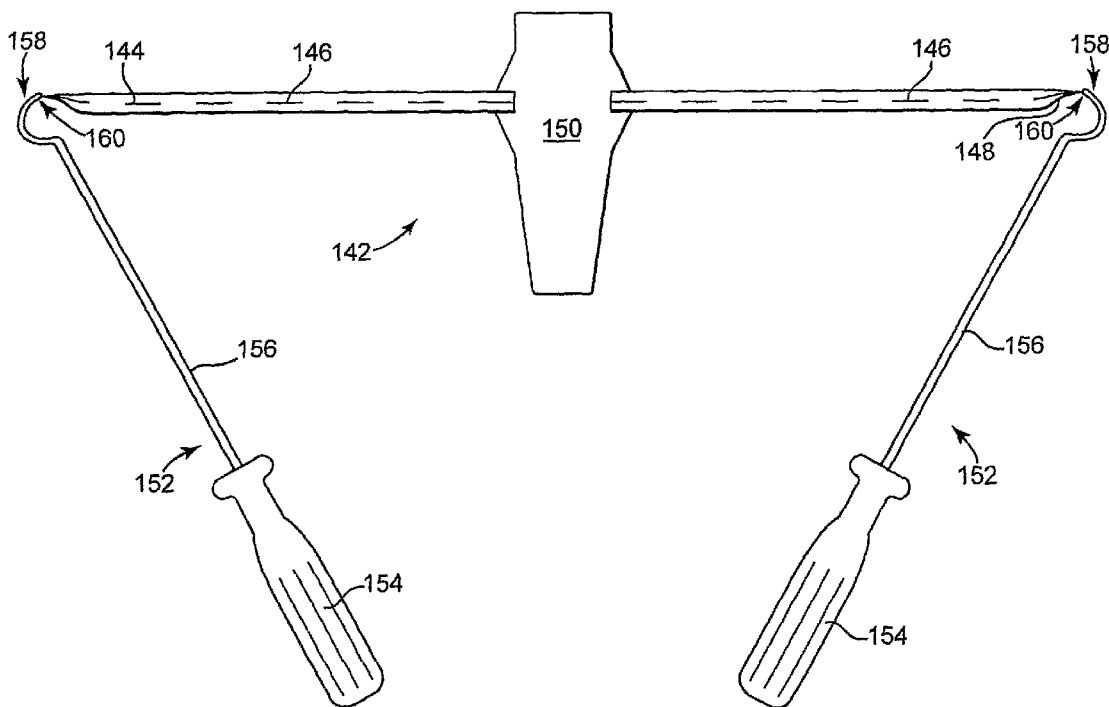

(57) Abstract: Described are implants, tools, and related methods, for use in pelvic surgery to treat conditions such as prolapse, including embodiments of methods that involve a tissue path above the arcus tendineus.

WO 2007/016083 A1

METHODS AND SYSTEMS FOR TREATMENT OF PROLAPSE

Priority Claim

The present non-provisional patent Application claims priority under 35 USC §119(e) from United States Provisional Patent Applications having serial number 60/702,704, filed on July 26, 2005, by James E. Cox and titled CONNECTORLESS IMPLANT SYSTEM; 60/702,705, filed on July 26, 2005, by Guillermo Wiley Davila et al. and titled TRANSVAGINAL SYSTEM FOR APICAL SUPPORT; and 60/702,700, filed on July 26, 2005, by James E. Cox et al. and titled METHODS AND SYSTEMS FOR TRANSVAGINAL TREATMENT OF PROLAPSE, wherein the entirety of these provisional patent applications are incorporated herein by reference.

Field of the Invention

Described herein are features of surgical articles, surgical methods, and surgical tools, for use in the field of pelvic surgery, e.g., to install support devices for use in treating vaginal prolapse.

Background

Medical conditions involving pelvic prolapse are conditions of great importance. An aging population can be prone to such conditions. Pelvic prolapse develops when intra-abdominal pressure, muscle failure, a surgical procedure such as a hysterectomy, or other factors, allow or cause a tissue of a pelvic organ such as the vagina to become displaced. Within the general category of pelvic organ prolapse, specific types include vault prolapse (apical); cystocele (anterior); rectocele and enterocele (posterior); and combinations of these.

- 2 -

Various techniques have been designed to correct or ameliorate prolapse and prolapse symptoms, with varying degrees of success. Nonsurgical treatments involve measures to improve the factors associated with prolapse, including treating chronic cough, obesity, and constipation. Other nonsurgical treatments may include pelvic muscle exercises or supplementation with estrogen.

A variety of surgical procedures have also been attempted for the treatment of prolapse. See for example United States patent application serial number 10/834,943, entitled "Method and Apparatus for Treating Pelvic Organ Prolapse," filed April 30, 2004, and serial number 10/306,179, entitled "Transobturator Surgical Articles and Methods," filed November 27, 2002, the entireties of each of these two patent applications being incorporated herein by reference. Such patent applications describe articles and methods for treating pelvic organ prolapse by use of a support member for supporting specific tissue. Application serial number 10/834,943, for example, discusses a support member that includes a central tissue support portion and two end (extension) portions, and related methods for implantation. The central tissue support portion can be attached at tissue of a vaginal vault. The end portions of the support member are then positioned through respective tissue pathways extending to an external incision at the perirectal region, to place the support member in a therapeutic position.

Methods of supporting vaginal tissue to treat vaginal prolapse can be differentiated in terms of the location of implanted materials or anatomical tissue used to support the vaginal tissue. One current method of treating posterior vaginal tissue prolapse involves the use of an intravaginal slingplasty ("IVS") tunneler device. Methods of treating prolapse using an IVS tunneler involve supporting

- 3 -

vaginal tissue by attaching a portion of a surgical implant to vaginal tissue and passing another portion of the implant through the iliococcygeus muscle below the white line, for support. A different technique, known as sacrospinous ligament fixation, involves supporting vaginal tissue by attachment to the sacrospinous ligaments. Both of these methods have drawbacks, such as not providing completely correct anatomical support for the vagina. Attaching vaginal tissue to the sacrospinous ligaments can pull the vagina down toward the pelvic floor. The use of an IVS tunneler to pass an implant through the iliococcygeous muscle allows for support from a location higher up in the anatomy, but still not an anatomically correct location.

Summary

The invention relates to transvaginal methods of treating posterior vaginal prolapse, and surgical devices. Embodiments relate to methods, tools, and surgical systems useful for transvaginal placement of an implant (e.g., a synthetic mesh implant or an implant that contains a combination of synthetic and biologic materials) in a position to support posterior tissue of the vagina, wherein the implant passes bi-laterally through opposing tissue paths that each include passage at a region of the arcus tendineus, e.g., near the ischial spine.

Some embodiments of methods may involve an external incision at a perirectal region, to place an extension portion of an implant, while alternate embodiments to not require and can avoid an external incision. The implant can be introduced to the pelvic region transvaginally; transvaginally attached to tissue of the vaginal vault for support; and then distal ends of the implant can be passed bi-

- 4 -

laterally near a region of each arcus tendineus (e.g., near both of the patient's ischial spines), as described, using a transvaginal procedure.

The tissue path through a region of the arcus tendineus can result in benefits including proper anatomical positioning of the supported vaginal tissue, and fixation of the implant in tissue near the arcus tendineus due to tissue ingrowth.

Additionally, exemplary transvaginal methods can allow for the location of extension portions to be adjusted by movement of the extension portion extending through the tissue path, e.g., through a tissue path that surrounds the arcus tendineus.

According to certain embodiments an implant can be used to treat vaginal vault prolapse. The support member can include a tissue support portion that can be attached to tissue of the vaginal vault and two end portions attached to the tissue support portion. The implant can be used to place vaginal tissue in a therapeutic position for treatment of vaginal vault prolapse by attaching the tissue support portion to tissue of the vaginal vault, and attaching the end portions to separate locations for positioning or supporting the prolapsed tissue.

Exemplary implants, methods, tools, and systems provide anatomical support to treat vaginal prolapse (e.g., vaginal vault prolapse, enterocele, and rectocele) by using a supportive implant attached to vaginal tissue, that passes from posterior vaginal tissue to a location in a region of the arcus tendineus ("white line"), e.g., near the ischial spine. The implant can pass from the point of attachment at the vaginal tissue, through a tissue path that includes passage through tissue at the immediately anterior edge of the ischial spine and at the level of the ischial spine near the connection of the ischial spine to the arcus tendineus, and above or below the arcus tendineus.

- 5 -

As used herein, the terminology that refers to positions “above” the white line refers to anatomy that includes the obturator internus muscle, and references to positions “below” the white line refer to anatomy that includes the iliococcygeus muscle. Stated differently, embodiments of the invention involve a tissue path that is defined to include a curved-rectangular-shaped area above and below the curved arcus tendineus. The region includes a specific region having a height extending from 2 inches above to 2 inches below the arcus tendineus, and a length starting at the ischial spine and extending 3 centimeters to the anterior of the ischial spine.

In one aspect, the invention relates to a method of supporting posterior vaginal tissue. The method includes: providing an implant comprising a tissue support portion and an extension portion extending from the tissue support portion, creating a vaginal incision, transvaginally contacting the support portion with posterior vaginal tissue, transvaginally producing a tissue path between the position of the tissue support portion and a region of the arcus tendineus, and transvaginally extending the extension portion through the tissue path.

In another aspect, the invention relates to a pelvic implant assembly that includes: an implant comprising supportive portions comprising a tissue support portion, and elongate extension portions extending from of the tissue support portion; and an insertion tool at a distal end of an extension portion, the insertion tool comprising a curved portion sized and shaped to be used in a transvaginal procedure to define a tissue path that exits the pelvic floor region in a region of the arcus tendineus, partially extends around an arcus tendineus, and re-enters the pelvic floor.

Brief Description of the Drawings

Figure 1 illustrates anatomy relevant to the invention, including specific pelvic anatomy.

Figure 2 illustrates anatomy relevant to the invention, including specific pelvic anatomy.

Figure 3 illustrates anatomy relevant to the invention, including specific pelvic anatomy, and also exemplifies an implant according to the invention.

Figure 4 illustrates an exemplary system of the invention including an exemplary tool and an exemplary implant with attached dilators.

Figure 4A is an end view of an exemplary tool.

Figure 4B is an end view of an exemplary tool with attached dilator of an implant.

Figure 5 illustrates an exemplary implant according to the invention.

Figure 6 illustrates an exemplary implant assembly according to the invention, including an implant and attached insertion tools.

Figure 7 illustrates an exemplary implanted pelvic implant according to the invention.

Figure 7A illustrates an exemplary implanted pelvic implant according to the invention.

Figure 8 illustrates an exemplary implanted pelvic implant according to the invention.

Figure 9 illustrates an exemplary implanted pelvic implant according to the invention.

- 7 -

Figure 9A illustrates an exemplary implanted pelvic implant according to the invention.

Figure 10 illustrates an exemplary kit or system according to the invention, including a Deschampes Needle, an implant, and a tunneler device.

Detailed Description

According to the invention, surgical implants can be used to treat conditions of vaginal prolapse. Also contemplated herein are various features of surgical implants, surgical tools, systems that include implant and tool, and surgical methods. The implants and tools are useful for treating conditions of vaginal prolapse including vaginal vault prolapse, but will also be appreciated to be useful for treating other conditions of pelvic tissue prolapse.

In general, the invention relates to methods, tools, and systems useful for attaching one portion of a surgical implant to pelvic tissue such as vaginal tissue and passing another portion of the implant through a tissue path that includes tissue in the region of the arcus tendineus or "white line," preferably near the ischial spine.

The location of this tissue path passing through a region of the arcus tendineus or "white line" can result in improved anatomical correctness of the position of supported vaginal tissue. The location in the region of the white line can provide a proper axis for supported vaginal tissue, higher than support provided by alternate methods of treating vaginal prolapse such as those that involve sacrospinous ligament fixation or use of the IVS tunneler, which alternate methods would typically produce a tissue path more directly through the buttocks. A location in the region of the arcus tendineus, e.g., above the arcus tendineus, does not cause vaginal tissue to be pulled down toward the pelvic floor as with attachment to the

- 8 -

sacrospinous ligaments. Also, a better vaginal length can result compared to the use of an IVS tunneler, because the support is located closer to the ischial spine.

Also advantageously, a tissue path can be one that wraps around the outside portion (relative to the region of the pelvic floor) of the arcus tendineus, meaning that an extension portion of an implant exits the pelvic region near the arcus tendineus (either above or below the arcus tendineus), continues along a path that wraps or bends around the white line, then re-enters the pelvic region on the other side of the white line; i.e., below or above the arcus tendineus, whichever is opposite of the direction of entry. The tissue path can include a relatively sharp turning radius to place the extension portion near the arcus tendineus. By extending around the white line, the extension portion contacts tissue that surrounds the white line and can become ingrown into that tissue. This ingrowth can provide fixation of the extension portion into the tissue. During the procedure the placement of the extension portion and implant can be adjusted by manipulating the extension portion from the pelvic region side, after passing the extension portion around the arcus tendineus. Specifically, the extension portion will include two portions within the pelvic region, and those two portions can be manipulated to adjust the position of one or more of the extension portion, a central portion of an implant, and tissue attached to a central portion of the implant.

Figure 1 schematically illustrates a top view of anatomy of vagina and nearby tissue. Vagina 2 and cervix 4 are schematically illustrated in relation to arcus tendineus or "white line" 6, ischial spine 8, and uterosacral ligaments 10. An exemplary region of a tissue path according to the invention, a region of the arcus tendineus, 6, is illustrated as an approximately-rectangular regions 12 (shown by

- 9 -

dashed lines -- one on each side of the pelvic region). Each region 12 includes area above and below arcus tendineus, 6, starting at ischial spine 8 and extending in an anterior direction along the length of the arcus tendineus. Although obturator internus and iliococcygeus muscles are not shown in figure 1, region 12 is located to include or be adjacent to the obturator internus muscle (above the white line) and the iliococcygeus muscle (below the white line); a tissue path that passes through region 12 also passes through obturator internus muscle or iliococcygeous muscle.

A preferred example of a region of the arcus tendineus, e.g., as illustrated as region 12, can be defined as a curved-rectangular-shaped area defined to include a region that extends 2 centimeters above and 2 centimeters below (e.g., 1 centimeter above and 1 centimeter below) the arcus tendineus and that has a length starting at the ischial spine and extending in an anterior direction along the arcus tendineus, e.g., a distance of up to about 3 centimeters anterior of the ischial spine (e.g., up to about 1 centimeter anterior to the ischial spine). A particularly preferred tissue path can be very near or as close as possible to the ischial spine and either above or below the arcus tendineus, such as through tissue at the immediately anterior edge of the ischial spine and at the level of the ischial spine near the connection of the ischial spine to the arcus tendineus; dimensions can be 0.5 or 1 centimeter above or below the arcus tendineus, and 0.5 or 1 centimeter anterior to the ischial spine along the arcus tendineus.

Figure 2, a top view of pelvic features, schematically illustrates sacrospinous ligament 11, arcus tendineus 6, ischial spine 8, sacrum 16, and exemplary tissue path 14 illustrated as circular line 14 passing around an outside of arcus tendineus 6, i.e., wrapping around arcus tendineus 6. This wrapped configuration places an implant

- 10 -

material near the arcus tendineus, e.g., in surrounding tissue such as surrounding muscle tissue, which allows for ingrowth of tissue into the implant material located at path 14, and fixation of that implant material at that location. Figure 2 illustrates an example of a circular tissue path, 14, that passes above arcus tendineus 6 near (e.g., within 2 centimeters, such as within 1 or 0.5 centimeters) ischial spine 8. Path 14 includes an arrow showing a direction of a needle (not shown) following path 14, starting below arcus tendineus 6, exiting the pelvic region by passing below the arcus tendineus and through the iliococcygeus muscle (levator ani) (not shown), passing around arcus tendineus 6, and then passing back into the pelvic region by passing above the arcus tendineus 6 through the obturator internus muscle (not shown).

Figure 2 illustrates what can be referred to as a “bottom-up” technique for passage of an end portion or extension portion of implant material through a region of the arcus tendineus. The bottom-up method inserts a distal end of an extension portion of an implant below the arcus tendineus and through the iliococcygeus muscle; the implant extension portion distal end is then passed around the back or outside of the arcus tendineus to a location above the arcus tendineus, and then through the tissue above the arcus tendineus (i.e., through the obturator internus muscle) where the implant end then re-enters the region of the pelvic floor.

Alternately, a tissue path as illustrated in figure 2 may be produced using a “top-down” method. As opposed to the bottom-up method specifically illustrated at figure 2, a top-down method inserts the implant extension portion distal end above the arcus tendineus through the obturator internus muscle, wraps the extension portion around the arcus tendineus, then the extension portion re-enters the region of

- 11 -

the pelvic floor below the arcus tendineus by passing through the iliococcygeus muscle. A top-down method may be a preferred method because top-down methods allow a needle tip to extend away from the bladder when passing through the obturator internus muscle. In a top-down method, the implant extension distal end, after wrapping around the arcus tendineus and re-entering the pelvic floor region (i.e., through the iliococcygeus muscle), may be led through one of various tissue path options. For example, the end extension may re-enter the pelvic floor region and then extend to and terminate at a location internal to the pelvic region. The distal end of the extension portion could be sutured, e.g., using a “stay suture,” to maintain placement within the pelvic floor. This method advantageously does not require an external incision for manipulating the extension portion. Another variation of the method is to use a tissue path as mentioned, but that continues through the pelvic region and then to and through an external incision such as through the buttock and then through an external incision, wherein the extension portion can be adjusted and cut off to a desired length.

As illustrated in figure 3, embodiments of the invention involve the use of a single mesh bridge (e.g., a uniform mesh strip) implant between tissue paths described herein, above the white line and optionally and preferably near the ischial spines, to repair vaginal vault prolapse. Optionally, if desired, a mesh strip implant may use a modified middle section with denser construction (e.g., use of a biologic material for a middle section, 22) to hold sutures better than standard mesh. A vaginal vault repair results in an anatomically correct “pear” shape to the distal vagina, with the vaginal vault correctly positioned between the ischial spines.

- 12 -

Referring to figure 3, this figure illustrates a top view of the anatomy of figure 1 including a mesh support implant 20 installed according to an exemplary tissue path described herein. Implant 20 includes central (tissue support) portion 22 sutured to the apex of vagina 2 by sutures 18 (designated as "x"s). Implant 20 also includes two end portions, 24 and 26, extending bilaterally from tissue support portion 22. Each of end portions 24 and 26 is illustrated to pass from apex of vagina 2, laterally toward arcus tendineus 6. Each end portion 24 and 26 passes above arcus tendineus 6, near ischial spine 8 -- i.e., through tissue at the immediately anterior edge of ischial spine 8 and at the level of the ischial spine near the connection of the ischial spine to the arcus tendineus -- through the obturator internus muscle (not shown), around arcus tendineus 6. In figure 3, extension portions 24 and 26 are shown to continue through tissue below the arcus tendineus (i.e., through the iliococcygeus muscle, not shown) and back into the pelvic floor region.

Referring still to figure 3, sections 21 and 23 of end portions 24 and 26 are located internal to the pelvic floor region. During a surgical implantation procedure, these portions can be manipulated by grasping manually or with a surgical instrument such as a forceps, needle-passer, or pliers, to adjust the position of end portions 24 and 26, as well as support portion 22 and overall implant 20.

The invention also relates to implants, tools, and kits, that may be used according to methods described herein, and that may also be useful for treating conditions other than vaginal prolapse, e.g., other types of pelvic tissue prolapse. In general, implants that may be useful according to methods described herein can include those types of implants known for use to treat vaginal prolapse, and similar

- 13 -

implants. Exemplary implants can be in the form of a biocompatible mesh material such as a mesh strip made of a single uniform length of mesh, or, alternately, can be a multi-portion implant that includes a support portion for attachment to pelvic (e.g., vaginal) tissue connected to end portions or extensions. Embodiments include a *length of mesh strip of generally uniform thickness and width*, as well as implants having distinct or discernible sections of different sizes, materials, or mechanical properties. Other exemplary embodiments include a tissue support portion of a biologic material and extension portions of synthetic mesh material.

Exemplary implants may be a mesh strip such as mesh strips and multi-component implants illustrated in the accompanying figures. As illustrated, exemplary implants may consist of a strip of uniform thickness and width, as well as implants that include portions of different sizes, shapes, and materials, for connecting to tissue and for supporting tissue. A tissue support portion may be of a biologic material or a synthetic (e.g., mesh) material. Attached to a tissue support portion can be one, two, or more, extensions (or “extension portions” or “end portions”) shaped and sized to extend from the point of attachment with the support portion of the implant to another location of the anatomy. Each extension may be an elongate material that is biologic or synthetic, e.g., an elongate synthetic mesh attached directly to the support portion.

Various implant products are available commercially for treating prolapse conditions, e.g., from American Medical Systems Inc., of Minnetonka Minnesota. Examples of such products include: the line of PERIGEE™ products for treatment of cystocele, from American Medical Systems, Inc.; the APOGEE™ product for treating enterocele, rectocele, and vaginal vault prolapse, also available from

- 14 -

American Medical Systems Inc.; as well as products for CAPS procedures (combined-prolapse-repair-with sling) for treating cystocele and stress urinary incontinence.

Examples of implants that can be used or modified for use according to the present description are described, e.g., in US application number 2004/0039453, "Pelvic Health Implants and Methods," (describing implants useful for treating multiple pelvic disorders) having serial number 10/423,662, and filed on April 25, 2003; US application number 2005/0245787, "Method and Apparatus for Treating Pelvic Organ Prolapse," having serial number 10/834,943, and filed on April 30, 2004; United States patent application serial number 11/347,063, filed February 3, 2006, entitled "Pelvic Implants and Related Methods; United States patent application serial number 11/398,368, filed April 5, 2006, entitled "Articles, Devices, and Methods for Pelvic Surgery"; and United States patent application serial number 11/243,802, filed October 5, 2005, entitled "Method for Supporting Vaginal Cuff" the entireties of each of these being incorporated herein by reference.

Exemplary implants can include a tissue support portion for placing in contact with tissue to be supported, and one or more "extension" portions (or "end portions"), the tissue support portion being useful to support pelvic tissue such as vaginal tissue (anterior, posterior, apical, etc.). The tissue support portion can be sized and shaped to contact the desired tissue when installed. A tissue support portion that is located between two or more extension or end portions is sometimes referred to herein as a "central support portion."

Dimensions of an implant or a portion of an implant can be as desired and useful for any particular installation procedure, treatment, or combination of

- 15 -

treatments, and to support a specific tissue, type of tissue, or multiple tissues (e.g., bladder, vagina, urethra, etc.). Exemplary dimensions can be sufficient to allow the tissue support portion to contact tissue to be supported and to allow one or more extension portion to extend from the tissue support portion to a desired anatomical location, e.g., through a tissue path through a region of the arcus tendineus, as described.

A tissue support portion can be sized and shaped to an overall area for contacting tissue being supported, and can depend on the condition being treated, e.g., vault prolapse, enterocele, rectocele, or a combination of these. The tissue support portion is of sufficient size and shape to at least partially surround or otherwise be in contact to support prolapsed tissue. A tissue support portion can optionally be of a width that is greater than a width of an extension portion. An increased width of a tissue support portion may take the form of one or two lateral extensions that extend the width of the tissue support portion in at least one direction, beyond the width of an extension portion. The shape of the tissue support portion can also be varied, depending on the intended application and treated condition, and may be square, rounded, angled, rectangular, etc. Exemplary widths of a tissue support portion, measured laterally (i.e., perpendicular to lengths of extension portions), can be in the range from 1 to 8 centimeters, such as from 2 to 6 centimeters. Generally, exemplary lengths of a tissue support portion can be up to 8 centimeters, such up to about 4 centimeters.

Extension portions are elongate pieces of material that extend from the tissue support portion and are integral with or connected to the tissue support portion. Extension portions are useful to attach to other anatomical features and thereby

- 16 -

provide support for the tissue support portion and the supported tissue. One or multiple (e.g., one, two, or four) extension portions can extend from the tissue support portion as elongate “ends,” “arms,” or “extensions,” that are used to attach to other anatomy. Extension portions extending from a tissue support portion in contact with posterior vaginal tissue, can be extended through a tissue path as described herein, passing through a region of the arcus tendineus such as above the arcus tendineus.

A width of an extension portion can be a width useful for implanting the implant and for providing desired strength and fixation properties during and after implantation and optional tensioning of the sling. Typical widths of an extension portion can be in the range from 0.5 to 3 centimeters, e.g., from 0.8 to 2 centimeters, such as from 0.8 to 1.5 centimeters. Extension portions can typically have a uniform or substantially uniform width along the length, normally not varying by more than about 25 percent of the average width along the length of the installed portion of the extension portion. A length of an extension portion can be as desired to extend from a tissue support portion installed at a desired pelvic tissue location, through a tissue path of a desired length, e.g., from a tissue support portion installed at a vaginal tissue, to a region above the arcus tendineus, optionally back into the pelvic cavity, and optionally further passing through the buttock to an exterior incision external to the buttock.

An example of a particular type of pelvic implant is the type that includes supportive portions including or consisting of a central support portion and two elongate extension portions extending from the central support portion. The term “supportive portions” refers to portions of an implant that function to support tissue

- 17 -

after the implant has been implanted, and specifically includes extension portions and a tissue support portion, and does not include optional or appurtenant features of an implant such as a sheath, dilator, attached or engaged insertion tool, or other connected tools or implantation aids. Figures 4, 5, and 6, for example, illustrate implants having supportive portions consisting of a tissue support portion and two elongate extension portions.

According to certain embodiments of implants, various features can be incorporated into a useful implant to facilitate installation of a device during a surgical procedure. For instance, a suture may be attached to an implant, along a length of an extension portion, for use in adding tension or in positioning the implant or a portion (e.g., extension) of the implant. Alternately or in addition an exemplary implant may include a removable sheath such as a flexible plastic, transparent elongate tube that can cover extension portions of an implant to allow a surgeon to apply tension or pressure on the sheath to indirectly apply pressure or tension to the extension portion, for placing or adjusting the location of the implant.

An implant can be installed according to the present description by use of standard surgical instruments, or by use of instruments that are designed or particularly useful for placing an extension portion through a tissue path as described, e.g., in a region of the arcus tendineus, such as above the arcus tendineus. Generally, an insertion tool may include a portion for creating a tissue path, that portion being curved or straight, with exemplary embodiments including a curved portion of a sized and shaped (e.g., length and curvature) that will be useful to form a tissue path as described herein, in a region of the arcus tendineus and preferably wrapping around the arcus tendineus, to lead a distal end of an extension portion at

- 18 -

least partially through a tissue path that wraps around the arcus tendineus. An exemplary length (measured as the circumferential arclength of the curved portion) of a curved portion can be from 3 to 5 centimeters, and an exemplary radius of curvature of a curved portion may be, e.g., in the range from 0.5 to 1.5 centimeters.

Exemplary geometric forms of a curved portion can be a form of a partial circle, such as a half circle. The partial circle is arranged to be in a plane that does not include a line defined by a longitudinal axis of a shaft. With this configuration, the curved portion can be located to define a partial circle having the shaft of the tool (and a longitudinal axis of the shaft) as a center of the circle. The curved portion can then engage tissue and be rotated around the shaft and longitudinal axis by rotation of the handle about the longitudinal axis, to cause the curved portion to define a circular tissue path. The partial circle can have a relatively uniform radius of curvature, such in the range from 0.5 to 1.5 centimeters (e.g., from 0.7 to 1.2 centimeters), extending over an arclength that traverses from 90 to 270 degrees, e.g., from 170 to 190 degrees, about 180 degrees. This arclength, when measured as the circumference of the partial circle, can be, e.g., from 3 to 5 centimeters.

An example of a useful insertion tool is a small curved needle attached at a distal end of an extension portion, which can be manipulated using a surgical instrument such as a forceps or pliers. The small curved needle can consist of a single length of curved needle material, e.g., metal or plastic, attached at a distal end of the extension portion. The needle may be considered to be a two-dimensional form, in that the curvature of the needle can define a two-dimensional plane. The small curved needle may be manipulated transvaginally and passed through tissue in a region of the arcus tendineus, preferably near the ischial spine. The needle is

- 19 -

curved to exit the pelvic region, wrap around the ischial spine, and then lead the extension portion back into the pelvic region to cause the extension portion to follow a tissue path that wraps around the arcus tendineus. The needle may then be removed by cutting the extension portion and the position of the extension portion may be adjusted by manipulation of portions of the extension portions that are located within the region of the pelvic floor.

Another example of a tool useful for placing an end portion of an implant transvaginally is a small three-dimensional looped needle such as a Deschamps needle or a similar needle that can be introduced transvaginally and that can then be used to pass an end portion of an implant through a tissue path in a region of the arcus tendineus, e.g., at the level of the ischial spine. The tool can be considered to include a shaft and curved end portion that exist in three dimensions, with the shaft defining a longitudinal axis and the curved end portion originating from that axis and extending in two additional directions. In use, an end portion of an implant may be attached to a tip of a curved distal portion of the tool and passed through tissue of a region of the arcus tendineus using the curved tip, transvaginally. For example, the curved distal end portion can be inserted transvaginally, and the handle can be rotated to rotate the curved distal end portion to define a circular tissue path. The needle is curved to exit the pelvic region, wrap around the arcus tendineus, and then lead the extension portion back into the pelvic region to cause the extension portion to follow a tissue path that wraps around the arcus tendineus. Optionally, according to certain exemplary methods, an additional surgical tool such as a tunneler (e.g., the IVS Tunneler device available commercially from Tyco) can be inserted through an external incision (e.g., in a perirectal region) into the pelvic region, attached to a

- 20 -

distal end of the extension portion, and then removed to lead the extension portion of the implant from the pelvic region to an external location.

An insertion tool or tools (e.g., Deschamps needle, or a small needle to be manipulated by a standard operating room tool such as a needle-driver) may engage a distal end of an extension portion of an implant by any useful engagement configuration. The engagement may be a permanent attachment or removable engagement, as desired.

According to certain embodiments of the invention, an insertion tool may be attached to the implant at a distal end of an extension portion. The term "attach," when used with regard to an end portion attached to an insertion tool, will refer to engagement configurations that are not easily removable, such as in a manner designed to be used during a surgical implantation method and that would normally be removed only by cutting the extension portion of the implant, as opposed to releasing (e.g., un-threading) the implant from the insertion tool. Examples of types of attachment mechanisms include attachment by adhesive such as a pressure sensitive adhesive, a structural adhesive, a two-part reactive adhesive such as an epoxy adhesive, etc.; a tight knot using thread or suture material that would not be easily untied during a surgical installation procedure; a non-removable mechanical interaction between the insertion tool and the implant portion such as by permanently threading the implant portion through an eye, eyelet, slot, or hole in the tool so the end portion is not easily removed; a metal or plastic mechanical attachment such as a metal crimp at the end of the insertion tool; a polymeric attachment such as the use of a heat-shrinkable polymeric sheath; attachment by a molding manufacturing process such as by injection molding or insert molding a

plastic dilator or plastic needle to a distal end of an extension portion; or any other mechanical or adhesive type of permanent or semi-permanent attaching mechanism. In contrast to an attachment, examples of types of removable engagement mechanisms include use of a loose knot that is easily untied during a surgical *implantation procedure*; an threaded dilator that removably engages a threaded needle tip for easy engagement and dis-engagement by threading and un-threading; and threading a distal end of an extension portion through an aperture (e.g., eye or eyelet) of an insertion tool such as a needle or a curved distal portion of a tool.

Attaching an insertion tool (e.g., dilator, needle, etc.) to a distal end of an extension portion of an implant eliminates the need for a surgeon to make that connection, which reduces preparation of the implant before or during surgery. The term "pre-attached" refers to an implant that includes an insertion tool attached to the implant as the implant is commercially supplied to a surgeon. The pre-attached device can be manufactured for distribution and sale in a condition where only minimal preparation (if any at all) needs to be performed by the surgeon prior to surgical implantation. Minimal preparation may include modification to size or shape of a portion of an implant (e.g., by trimming), or removing loose material or loose pieces, but does not include a step of creating a direct attachment between a portion of the implant and an insertion tool that will allow the portion of the implant to be placed or led through a tissue path.

Thus, embodiments of optional features of implants include an insertion tool that is attached e.g., pre-attached, or alternately is removably engaged, at a far (i.e., distal) end of an extension portion of an implant, the tool being a structure that facilitates installation of the extension portion and implant by being of a size, shape,

- 22 -

rigidity, and overall design, to be capable of being used transvaginally to create a tissue path that passes through tissue in a region of the arcus tendineus, optionally and preferably wrapping around the arcus tendineus. Examples of insertion tools that may be either attached or removably engaged to a distal end of an extension portion include: a tip (distal end) of an extension portion that includes an attached rigid tip or "dilator," optionally designed to cooperate and removably engage an end of another insertion tool for use together to create a tissue path during installation of an implant; a distal end of an extension portion that is permanently attached to an insertion tool in the form of a curved distal needle portion and a shaft and proximal handle portion, or another tool that can be inserted transvaginally to manipulate an extension portion of an implant during installation; and a distal end of an extension portion that is permanently attached to an insertion tool such as a small needle that can be manipulated by a grasping tool such as a needle driver, a forceps, or a pliers, etc., to manipulate an extension portion of an implant during transvaginal installation.

As one exemplary design, an implant may include a rigid (e.g., plastic), pushable dilator attached at a distal end of an extension portion, the dilator including a sharp tip at a first end and an opening at an opposing end, the opening designed and adapted to fit and removably engage an end of an insertion tool such as a needle. The pushable dilator can be designed to fit the leading edge of an insertion tool such as a long needle having a handle and a distal portion with a tip adapted to fit and removably engage the pushable dilator. The dilator can engage the end of the insertion tool and may be pushed or pulled by the insertion tool through tissue to either follow or produce a path in the tissue, such as by rotating the handle to cause

- 23 -

the distal portion to produce a curved tissue path. To produce a path in the tissue by pushing the dilator through the tissue, the pushable dilator can be sufficiently sharp and rigid to pass through tissue when pushed using the needle (e.g., by rotating the needle).

A dilator (whether or not sufficiently sharp and rigid to be “pushable”) may be straight, or, according to certain specific embodiments of the invention, may be curved in a manner that will improve manipulation of the dilator during a surgical procedure, e.g., in a manner that will facilitate pushing the dilator through tissue to either produce or follow a particular path of tissue. Optionally for use with methods described herein with a tissue path in the region of the arcus tendineus, e.g., that wraps around the arcus tendineus, the external size and shape of a dilator may be suited to produce a tissue path that curves around the arcus tendineus, e.g., to exit the pelvic region by passing through the obturator internus above the arcus tendineus, pass behind the arcus tendineus, and re-enter the pelvic region by passing through the levator ani at a location below the arcus tendineus. The curved dilator may be considered to be a two-dimensional form, in that the curvature of the dilator can define a two-dimensional plane.

As exemplary dimensions, a curved dilator may include a curved portion that has a radius of curvature in the range from 0.5 to 1.5 centimeters and a length (measured as the arclength of the curved portion) of from 3 to 5 centimeters. Also optionally, a curved shape or radius of a curved dilator can approximate or match a curved shape or radius of an insertion tool (e.g., a curved distal portion of an insertion tool such as a curved distal needle), and the curves of both a dilator and a curved distal portion of an insertion tool (e.g., needle) may be shaped to match a

- 24 -

tissue path that exits the pelvic area at a location near the ischial spine and above the arcus tendineus by passing through the obturator internus muscle, continues around the arcus tendineus, and re-enters the pelvic region below the arcus tendineus by passing through the levator ani muscle. Thus, according to certain specific embodiments of the use of a curved dilator, a curved dilator may be used with a curved needle (or other insertion tool) designed to fit within an internal space at a hollow interior of the dilator, with the curved insertion tool and the curved dilator having a size and shape to define a tissue path passing around the arcus tendineus as described.

Further design features can relate to dilators and insertion tools that include anti-rotation or alignment features, in particular with the use of a curved needle insertion tool and a curved dilator. An anti-rotation or alignment feature may be in the form of opposing and coordinated structural features of the dilator and a tip of an insertion tool (e.g., needle) that together can: interconnect the dilator and tip of insertion tool to produce a desired alignment; prevent relative movement of the two pieces such as to prevent rotation of the dilator relative to the tool; or both. The alignment feature causes the dilator to be placed on the needle in a specific alignment, which if the needle and dilator are both curved as discussed above, causes the curve of the needle to be aligned with the curve of the dilator. An example of an alignment and anti-rotation feature is a keyed structure, as will be understood, that includes one or more inter-connecting surfaces and structures between the dilator and the needle to allow the dilator to removably connect to the needle when the two are properly aligned, and then to also prevent rotation between the two when the two are connected. Other mechanical structures will also allow the

- 25 -

dilator to be attached at an end of a needle in a manner to produce a desired alignment and to prevent rotation of the dilator relative to the needle.

An example of an implant having a curved (two dimensional) dilator adapted to removably engage a three dimensional insertion tool that includes a curved (two dimensionally curved) distal end, is illustrated at figure 4. Figure 4 schematically illustrates a prolapse support device (i.e., implant) 110 for treating vaginal prolapse, and insertion tool 122. Implant 110 includes end (i.e., "extension") portions 114 and 116 connected to central support portion 120. Sutures (optional) 118 extend along the lengths of each of extensions 114 and 116 and are connected to central support portion 118 and extensions 114 and 116. Rigid, curved dilators (in two dimensions) 112 are attached at each distal end of extension portions 114 and 116.

Still referring to figure 4, insertion tool 122 (not to scale) includes handle 124, shaft 126, and curved distal portion or "needle" 128. (Needle 128 includes a two-dimensional semi-circular form, and needle 128 along with shaft 126 together are in three dimensions.) Needle 128 is designed to engage dilators 112 by fitting inside of a dilator 112, e.g., inside of internal space 113 of each dilator, so that needle 128, by use of handle 124 of tool 122, can be used to push dilator 112 through tissue by rotating handle 124; rotation of handle 124 about axis 121, defined by handle 124 and shaft 126, rotates curved needle 128. Curved needle 128, shaft 126, and handle 124 are in three dimensions. Curved needle 128 is substantially a partial circle (e.g., half circle) that rotates to define a curved tissue path when handle 124 is rotated about longitudinal axis 121. Not shown is an optional protective flexible cover or sheaths that could extend over and contain extension portions 114 and 116.

- 26 -

Figure 4A shows an end view of tool 122, illustrating the half-circle shape of curved end 128, in view of handle 124. Curved end 128 includes an arclength of approximately 180 degrees, starting at a trailing end 129 that connects to shaft 126, and extending to needle tip 127. Figure 4B illustrates these features of tool 122 when connected to dilator 112, which is also attached to extension portion 116 of implant 110.

According to other embodiments of implants, distal ends of extension portions can be attached or engaged with an insertion tool in the form of a needle or in the form a tool comprising a distal curved portion (e.g., needle) with attached shaft and handle, the former needle being capable of being manipulated using a separate tool such as a needle-driver, forceps, or surgical pliers, the latter type of needle being capable of being manipulated using the handle, which will be external to the patient during a transvaginal surgical procedure. Thus, exemplary insertion tools include a small two-dimensional needle that can be manipulated during a transvaginal installation by another surgical tool; a tool having a distal portion comprising a curved needle (including a needle tip), shaft, and handle, that can be used directly to install the implant; a dilator; or another type of tool that can be used to allow ends of an extension portion of an implant to be transvaginally installed in tissue as desired.

A specific example of an attached insertion tool can be a small needle that can be securely attached at distal end of an extension portion of an implant. The needle can be straight or curved (e.g., in two dimensions), and may preferably be sized to be manipulated using a standard surgical grasping instrument such as a pliers, forceps, or needle-passer, and can be can be shaped and sized as desired, such

- 27 -

as with a curve and length that facilitate passing the needle through a tissue path that wraps around an arcus tendineus. For example, pre-attached small, two-dimensional curved needle may include a curved portion that has a radius of curvature in the range from 0.5 to 1.5 centimeters and a length (measured as the arclength of the curved portion) of from 3 to 5 centimeters. A distal end of an extension portion of an implant may be attached at a trailing end of the needle. (Attachment at trailing end of a needle or at a leading end of a needle refers to attachment that is within a distance of an end of a needle of 25 percent of the total needle length.) The attached insertion tool (e.g., needle) can optionally include useful features that allow manipulation and placement of the needle as desired to place the implant in a useful position. For example, a needle may include flat portions that allow easy grasping and manipulation with a standard needle-driver, forceps, or pliers. The needle may be plastic or metal. The curve and sizing of the needle can be shaped to match a tissue path that exits the pelvic area at a region of the arcus tendineus, wraps around an arcus tendineus, and re-enters the pelvic region.

Figure 5 schematically illustrates a prolapse support device for treating vaginal prolapse, the device including attached insertion tools in the form of small curved two-dimensional needles having length L and radius of curvature R . Implant 130 includes end portions 134 and 136 connected to central support portion 140. Sutures 138 extend along the lengths of each of extensions 134 and 136 and are connected to central support portion 140 and extensions 134 and 136. Attached insertion tools 132, in the form of small curved two-dimensional needles, are attached to distal ends of extensions 134 and 136. Length L (the arclength of each needle) can be as desired, e.g., from 3 to 5 centimeters. Curvature of radius R can

- 28 -

be as desired, e.g., from 0.5 to 1.5 centimeters. Insertion tools 132 are designed to be transvaginally manipulated by a tool such as a needle driver, surgical pliers, surgical forceps, etc., during installation of implant 130, e.g., according to methods described herein.

Figure 6 schematically illustrates a prolapse support device that includes an implant having two pre-attached insertion tools. Implant 142 includes end portions 144 and 148 connected to central support portion 150. Sutures 146 extend along the lengths of each of extension 144 and 148 and are connected to central support portion 150 and extensions 144 and 148. Insertion tools 152 include shaft 156, handle 154, and curved distal portion, needles 158, each needle being attached at a distal end of extension portions 144 and 148.

Each tool 152 includes handle 154, shaft 152, curved needle end 158 at a distal end of shaft 152, and needle tip 160. Tips 160 are leading edges of curved needles 158, and each is attached to a distal end of an extension portion 144 or 148. With this design, a surgeon receives the implant product 142 with tools 152 attached; the surgeon installs implant 142, transvaginally, with support portion 150 being attached to vaginal tissue. The surgeon uses each of tools 152 to place ends of extension portions 146 and 148 bilaterally through tissue in the region of the arcus tendineus, e.g., near the ischial spine. Curved distal end 158 of each tool 152 allows the surgeon to lead a distal end of each extension portion 144 and 148 around the outside of the arcus tendineus and back into the pelvic region at a location below the arcus tendineus, e.g., through the iliococcygeous muscle. This placement can be performed by movement of each tool 152, the movement including rotation of handle 154 about an axis that includes shaft 156, to rotate curved distal end 158, also

- 29 -

about the axis of shaft 156. This can pass tip 160 and a distal end of an extension portion around an arcus tendineus, with the distal end exiting and re-entering the pelvic region. The surgeon can then disconnect the end of each extension portion from each tip 160 by cutting the extension portions 144 and 148 near tip 160 of each tool 152. After cutting the end of each extension portion 144 and 148, the needle and tool can be removed from the pelvic region and each extension portion 144 and 148 can be manipulated to adjust and position the extension portion and implant 142 as desired to support vaginal tissue connected to support portion 150. This can optionally include producing another tissue path to an external location and leading the end of each extension portion 144 and 148 through that tissue path to the external location in the perirectal region such as is illustrated in figures 7 and 9. Or, each extension portion 144 and 148 can be severed and severed ends can be left at locations within the pelvic floor region without leading extension portions 144 and 148 to an external incision.

According to particular embodiments, a kit according to the invention can include an implant and a tool or multiple tools for installation, e.g., with the insertion tool being either removably enjoyable or attached (e.g., permanently) at a distal end of an extension portion of the implant. Referring to figure 10, a kit is illustrated (not to scale) to include a mesh tape implant (220) for supporting vaginal tissue, insertion tool 200 comprising a distal end having a curved needle, and tunneling device 230. Figure 4 includes an illustration of an exemplary insertion tool useful for installing a mesh to pass above the arcus tendineus. Tool 200 (Deschamps Needle) of figure 10 is shown as a side view. Tunneling device 230 (e.g., IVS tunneling) includes hollow trocar 232 and flexible plastic plug 234, as are known.

- 30 -

Tool 200 includes handle 202, shaft 204 having a proximal end connected to handle 202, shaft 204 connected at a distal end to curved end (e.g., "needle") 208. The diameter of the curved needle portion 208 is shown to be 1 inch, meaning that the radius of curvature is about 0.5 inch; other sizes of the curve may also be useful. Curved end 208 defines a two-dimensional curve, and the combination of curved end 208 with shaft 204 together are in three dimensions.

Still referring to figure 10, tip 210 of curved end 208 can be adapted to allow an end of a mesh implant to be held (removably engaged) by tip 210. Tip 210 can also be sharpened to allow the tip to be passed through tissue. Tool 200 may be a Deschamps Needle or similar structure having a handle, shaft, and a curved portion at the end of the shaft. A distal end (222) of mesh implant 220 can be attached to the end (tip) of curved portion of curved needle 208 of tool 200. During use, a surgeon can make a vaginal incision to allow transvaginal insertion of curved end 208 of tool 200, with a distal end 222 of implant 220 attached at the end (tip) 210 of curved portion 208. Center portion 224 of implant 220 is attached to the vaginal apex to provide support, and each of ends 222 can be extended bi-laterally through tissue paths that pass through a region of the arcus tendineus, such as through the *obturator internus muscle just above the arcus tendineus at the level of the ischial spine*. Tunneler device 230 can be used to separately retrieve each of ends 222 of mesh implant 220 and draw ends 222 through a tissue path to an external incision, e.g., an external incision in the perirectal region.

The invention contemplates placement of an implant, as described, to treat a condition of vaginal tissue prolapse, by use of transvaginal surgical methods. The present description identifies certain combinations of implants, tools, and

- 31 -

procedures, but as will be understood based on the present description, many different variations on the present methods, tools, and procedures will be useful, as will combination of implant, tool, and procedure.

According to one embodiment of the invention, using a curved Deschamps or similar needle, an extension portion of an implant can be inserted through a vaginal incision and a central portion of the implant can be attached to vaginal tissue that is to be supported. Two opposing tissue paths are created from the vaginal tissue to regions of the arcus tendineus, e.g., above the arcus tendineus at a level of the ischial spine, one on each side of the pelvic region. Each end ("extension") portion of the implant can then be extended through a tissue path and above or below the arcus tendineus, such as through the obturator internus muscle or iliococcygeus, optionally also as close to the ischial spine as possible, using the curved needle. The end portion of the implant is passed around the outside of the white line and passed back into the pelvic region either below or above the white line, either through obturator internus or the iliococcygeus muscle. This location of the mesh end is illustrated in figures 7, 7A, 8, 9, and 9A. The end of the mesh thus passes back into the pelvic floor and can be subsequently passed through a tissue passage that is created below that pelvic floor location, to an incision made external to the rectal region at each buttock (e.g., 2 to 3 centimeters lateral and 2 to 3 centimeters posterior to the anus).

Methods of the invention can involve placement of an implant and extension portion using a system as shown in figure 4. Distal curved portion 128 of tool 122 is engaged with interior space 113 of dilator 112, and tool 122 can be inserted transvaginally and rotated to produce a tissue path in a region of the arcus tendineus.

- 32 -

Tool 122 then engages the second dilator to make a second opposite tissue path, transvaginally. Each extension portion can be adjusted as desired, and tissue support portion 120 can be attached to vaginal tissue and adjusted. In alternate embodiments that also use tool 122 and implant 110, a tissue path can be produced transvaginally using tool 122, as a first step, then dilator 112 can be engaged with distal end 128 after formation of the tissue path. After engaging dilator 112 and distal end 128, tool 122 can be counter-rotated to cause the dilator to be pulled back through the tissue path. The extension portion and tissue support portion 120 can then be adjusted.

Methods of the invention include variations that advantageously do not require any external incision such as two incisions perirectal incisions. Again entering the pelvic region transvaginally, e.g., using a curved Deschamps Needle (or alternately a small curved needle as shown in figure 5), an extension portion of an implant can be inserted through a vaginal incision and a central portion of the implant attached to vaginal tissue that is to be supported. Opposing tissue paths are created starting at the vaginal tissue and extending to opposite locations at regions of the arcus tendineus, e.g., above the arcus tendineus at the level of the ischial spine. Each end portion of the implant can then be extended through one of the opposing tissue paths and through obturator internus muscle, as close to the ischial spine as possible. The end portion of the implant is passed (wrapped) around the outside of the white line and passed back into the pelvic region below the white line, through the iliococcygeus muscle. The end of the mesh thus passes back into the pelvic floor. Instead of passing the end portion through a tissue passage that is created between that pelvic floor location and an external incision (e.g., in the rectal region

- 33 -

at each buttocks), however, the end portion can be cut off, e.g., within the pelvic region, and the severed end left in that internal position of the anatomy. The end portion may optionally be secured using a suture. The severed end portions of the implant will remain in place within the defined tissue path and will the implant will support the vaginal tissue.

Figure 7 illustrates an installed mesh tape implant 220 (e.g., as shown in figure 10) that includes a central support portion (224) secured to tissue of the vaginal apex. Each of two distal ends 222 of extension portions 221 of implant 220 extends bilaterally to pass above each arcus tendineus (6), near each ischial spine (8). Each of the two distal ends 222 of extension portions 221 of implant 220 then passes thorough the iliococcygeus muscle (not shown), below the white line (6), back to the pelvic floor region and then through two tissue paths, each path extending to an external incision (70) in the perirectal region.

Figure 7A illustrates an alternate embodiment of an installed mesh tape implant 220 (e.g., as shown in figure 10) that includes a central support portion 224 secured to tissue of the vaginal apex. Each of two extension portions 221 of implant 220 extends bilaterally to pass above each arcus tendineus (6) near each ischial spine (8). Each of the two extension portions 221 of implant 220 then passes thorough the iliococcygeus muscle (not shown) below the white line (6) and back to the pelvic floor region. Each of the two extension portions 221 of implant 220 is severed to create an end of the extension portion located within the pelvic floor and extension portions 221 are not extended through tissue paths to any external incision.

Figure 8 illustrates another view of an installed mesh tape implant, such as implant 220 shown in figure 10. Figure 8 looks in a direction down into the pelvic

- 34 -

cavity, such as from a position in the abdomen. For reference are shown pubic bone 80, bladder 82, obturator internus muscle 84, and iliococcygeous muscle 86. In figure 8, a central support portion 224 of a mesh implant 220 is secured using sutures (not shown) to tissue of the apex of vagina 2. Each of the two distal ends 222 of extension portions 221 of implant 220 are extended bilaterally and passed through opposing tissue paths above each arcus tendineus (6), near each ischial spine (8), e.g., through obturator internus muscle 84. The far portions and distal ends 222 of the extension portions 221 of implant 220 are not shown in figure 8. These far portions of extension portions 221 may extend through alternate tissue paths, such as back into the pelvic region by passing through iliococcygeous muscle 86 at a location below arcus tendineus 6, then either severed at a location within the pelvic floor region or passed to an external incision.

Figure 9 illustrates still another view of an exemplary installed mesh tape implant 220 that includes central support portion 224 secured to tissue of the vaginal apex. Figure 9 is a view from exterior of the patient, facing the vagina and anus (90). Each of two distal ends 221 of the implant 220 extends bilaterally to pass above each arcus tendineus 6 near each ischial spine 8, around the arcus tendineus 6, and then through the iliococcygeus muscle (not shown) below the white line 6 and back to the pelvic floor region. From there each extension portion 221 passes through a tissue path extending to an external incision (70) in the perirectal region.

Figure 9A illustrates an alternate embodiment of an installed mesh tape implant that includes a central support portion 224 secured to tissue of the vaginal apex. Figure 9 is a view from exterior of the patient, facing the vagina and anus (90). Each of two extension portions 221 of implant 220 extends bilaterally to pass

- 35 -

above each arcus tendineus 6 near each ischial spine 8. Each of the two extension portions 221 of the implant 220 then passes around arcus tendineus 6 and then through the iliococcygeus muscle (not shown) below the white line 6 back to the pelvic floor region. Each of the two ends of the implant is severed to create an end that remains internally within the pelvic floor, and the end portions are not extended through tissue paths to external incisions in the perirectal region.

Claims:

1. A method of supporting posterior vaginal tissue, the method comprising
providing an implant comprising a tissue support portion and an extension portion extending from the tissue support portion,
creating a vaginal incision,
transvaginally contacting the support portion with posterior vaginal tissue,
transvaginally producing a tissue path between the position of the tissue support portion and a region of the arcus tendineus,
transvaginally extending the extension portion through the tissue path.
2. The method of claim 1, comprising treating a condition selected from the group consisting of enterocele, rectocele, apical prolapse, and vault prolapse.
3. The method of claim 1 wherein the region of the arcus tendineus includes the region from 2 centimeters above the arcus tendineus to 2 centimeters below the arcus tendineus and between the ischial spine and a distance 3 centimeters anterior to the ischial spine.
4. The method of claim 1 wherein the region of the arcus tendineus includes the region between the arcus tendineus and 1 centimeter above the arcus tendineus, and between the ischial spine and a distance 1 centimeter anterior to the ischial spine.
5. The method of claim 1 wherein the tissue path passes above the arcus tendineus to exit a pelvic region through the obturator internus muscle, wraps around

- 37 -

the arcus tendineus, and passes through the levator ani muscle back into the pelvic region.

6. The method of claim 1 wherein the tissue path passes above the arcus tendineus through the obturator internus muscle, wraps around the arcus tendineus, passes through the levator ani muscle back into the pelvic region, continues through the buttock and through an external incision in a perirectal region.

7. The method of claim 1 comprising

- providing an implant assembly comprising an implant comprising a tissue support portion, two extension portions, and one insertion tool attached at a distal end of each extension portion, the insertion tool comprising a proximal handle and a curved needle at a distal portion,
- creating a vaginal incision,
- transvaginally placing the tissue support portion in contact with vaginal tissue,
- inserting a first curved needle with attached first extension portion through the vaginal incision,
- manipulating the handle of the first insertion tool to lead the distal end of the first extension portion through a first tissue path in a region of an arcus tendineus,
- inserting a second curved needle with attached second extension portion through the vaginal incision, and
- manipulating the handle of the second insertion tool to lead the distal end of the second extension portion through a second tissue path in a region of an arcus tendineus.

- 38 -

8. The method of claim 1 comprising

providing an implant assembly comprising an implant comprising a tissue support portion, two extension portions, and one needle attached to a distal end of each extension portion, each needle having a leading end and a trailing end, the distal end of each extension portion being attached to the trailing end of each needle,

creating a vaginal incision,

transvaginally placing the tissue support portion in contact with vaginal tissue,

inserting a first needle with attached end of first extension portion through the vaginal incision,

transvaginally manipulating the first needle to lead the distal end of the first extension portion through a first tissue path in a region of an arcus tendineus,

inserting a second needle with attached end of second extension portion through the vaginal incision, and

transvaginally manipulating the second needle to lead the distal end of the second extension portion through a second tissue path in a region of an arcus tendineus.

9. The method of claim 1 comprising

providing an implant assembly comprising an implant comprising a tissue support portion, two extension portions, and a curved dilator attached to a distal end of each extension portion,

- 39 -

providing a surgical tool comprising a handle, a shaft, and a curved distal end, the curved distal end capable of engaging a curved dilator,

creating a vaginal incision,

transvaginally placing the tissue support portion in contact with vaginal tissue,

engaging the curved distal end with a first dilator and inserting a first dilator with attached end of first extension portion through the vaginal incision,

transvaginally manipulating the first dilator to lead the distal end of the first extension portion through a first tissue path in a region of an arcus tendineus,

engaging the curved distal end with a second dilator and inserting the second dilator with attached end of second extension portion through the vaginal incision,

transvaginally manipulating the second dilator to lead the distal end of the second extension portion through a second tissue path in a region of an arcus tendineus.

10. A pelvic implant assembly comprising
an implant comprising supportive portions comprising
a tissue support portion, and
elongate extension portions extending from of the tissue support portion, and
an insertion tool at a distal end of an extension portion, the insertion tool comprising a curved portion sized and shaped to be used in a transvaginal

- 40 -

procedure to define a tissue path that exits the pelvic floor region in a region of the arcus tendineus, partially extends around an arcus tendineus, and re-enters the pelvic floor.

11. The assembly of claim 10 wherein the curved portion has a radius of curvature in the range from 0.5 to 1.5 centimeters and a length of from 3 to 5 centimeters.

12. The assembly of claim 11 wherein the curved portion is substantially a shape of a partial circle of from 90 to 270 degrees.

13. The assembly of claim 11 wherein the curved portion is substantially a shape of a partial circle of from 170 to 190 degrees.

14. The assembly of claim 10 wherein the insertion tool comprises
a handle having a longitudinal axis,
a shaft having a proximal end and a distal end, the proximal end of the shaft attached at the distal end of the handle, the shaft having a longitudinal axis aligned with the longitudinal axis of the handle, and
a curved portion at the distal end of the shaft, the curved portion having a radius of curvature in the range from 0.5 to 1.5 centimeters and a length of from 3 to 5 centimeters.

15. The assembly of claim 14 wherein the distal end of the extension portion engages a leading end of the needle.

16. The assembly of claim 14 wherein the tool is capable of being used to transvaginally place the curved portion in contact with tissue in a region of the arcus tendineus, and the handle can be manipulated with movement that includes rotation

- 41 -

of the handle about a longitudinal axis through the shaft to cause the curved portion to produce a tissue path.

17. The assembly of claim 10 wherein the insertion tool is a curved needle having a radius of curvature in the range from 0.5 to 1.5 centimeters and a length of from 3 to 5 centimeters, and wherein a distal end of the extension portion is attached at a trailing end of the needle.

18. A kit comprising the assembly of claim 17 and a surgical grasping tool capable of manipulating the curved needle transvaginally, the surgical grasping tool selected from a surgical forceps, a surgical needle-passer, and a surgical pliers.

19. The assembly of claim 10 wherein the insertion tool is a curved dilator.

20. A kit comprising the assembly of claim 19 and a tool comprising a proximal handle and a distal curved portion, the distal curved portion being capable of engaging the curved dilator.

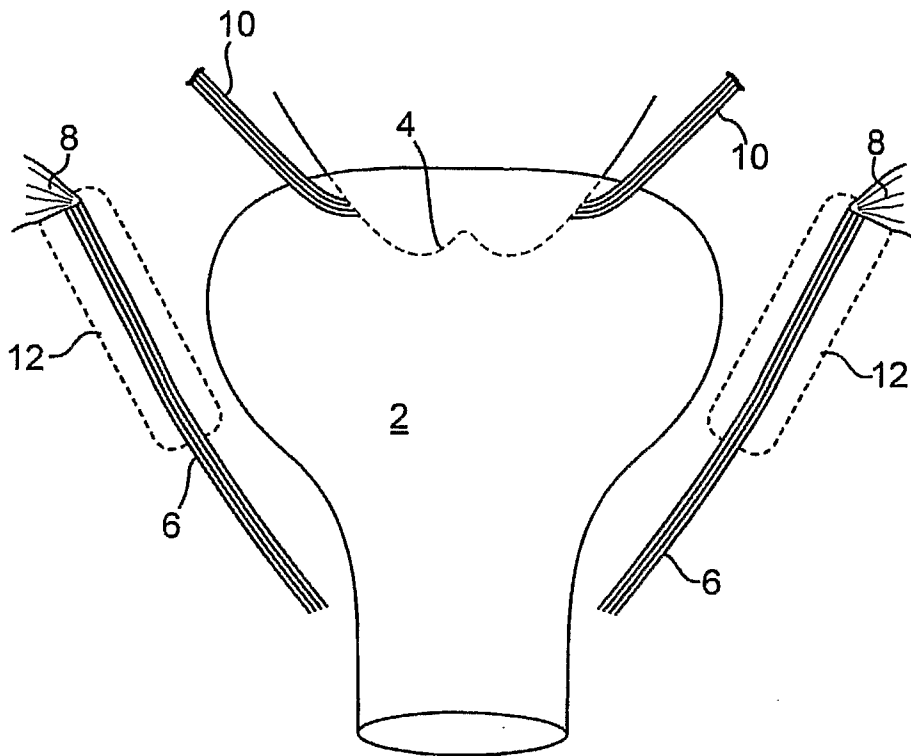

Fig. 1

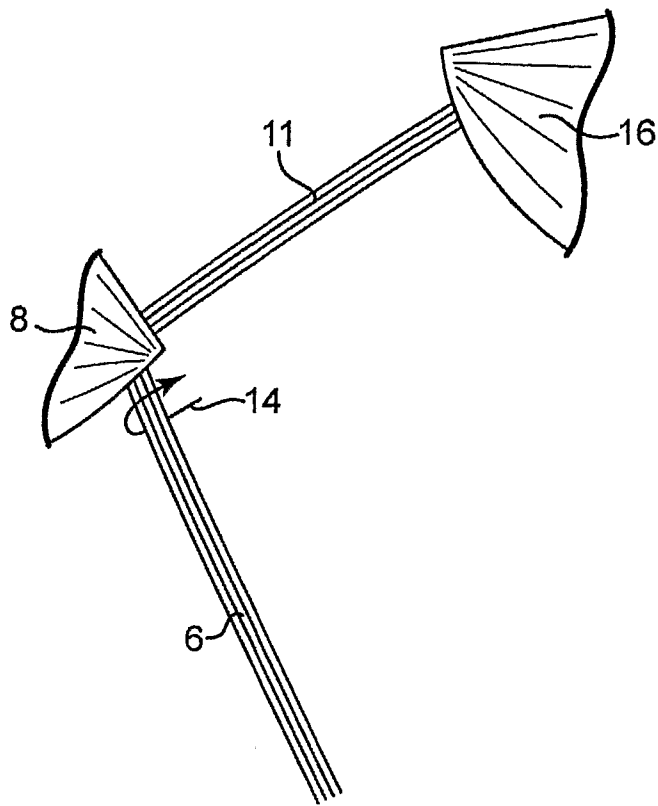

Fig. 2

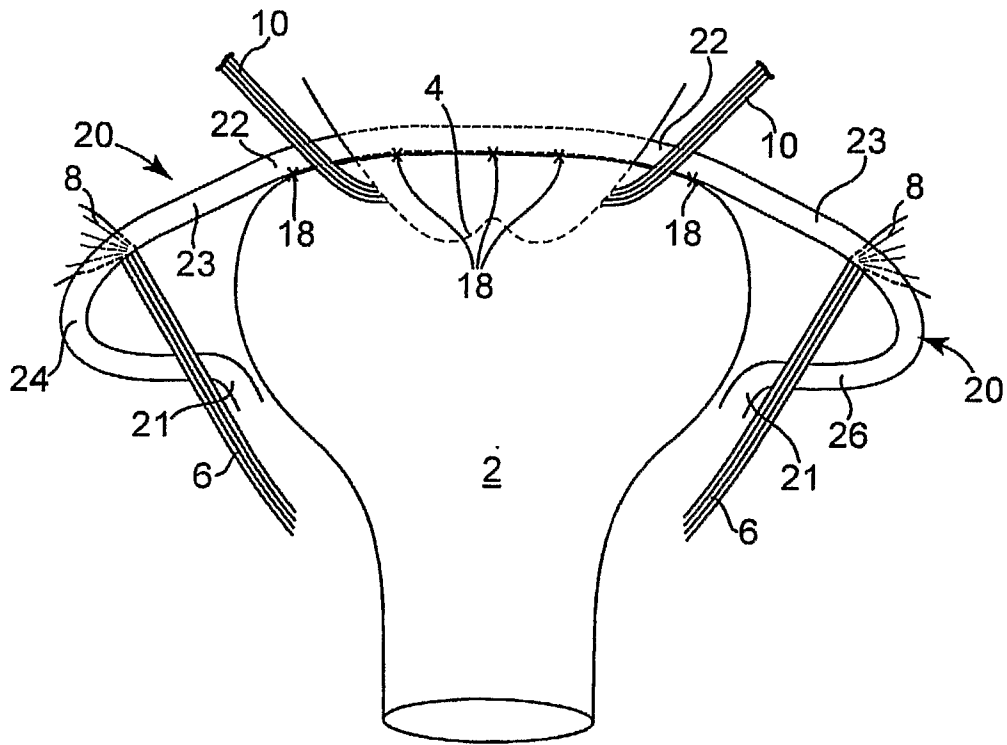

Fig. 3

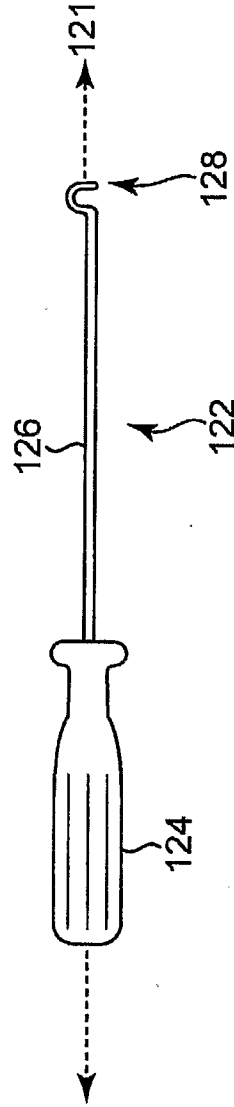
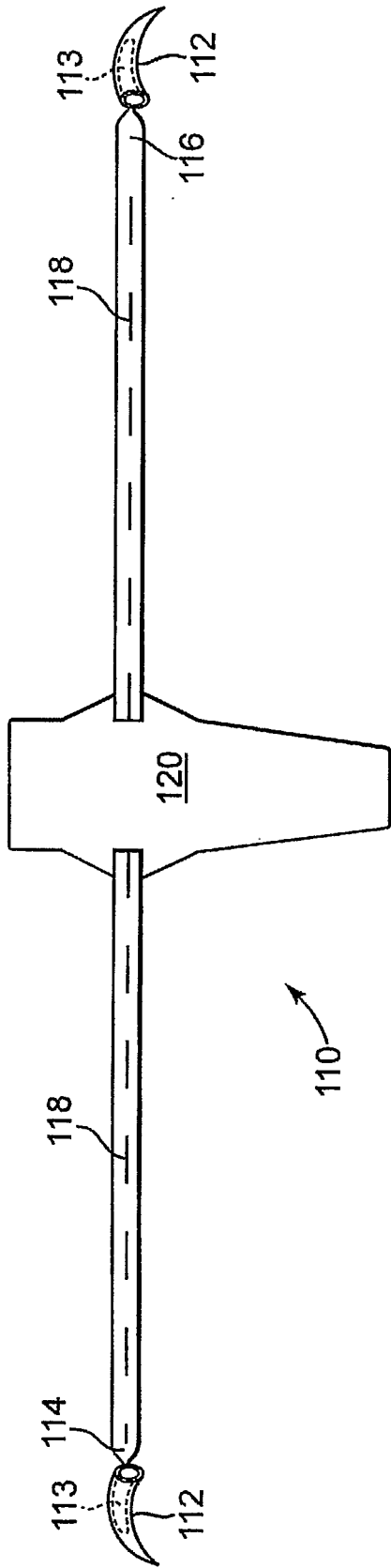

Fig. 4

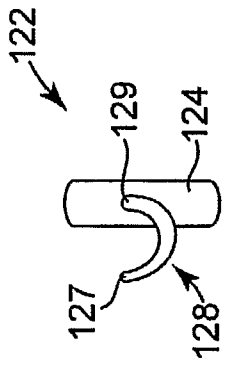

Fig. 4A

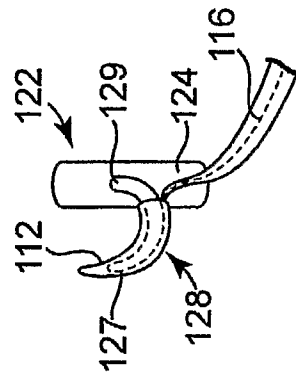

Fig. 4B

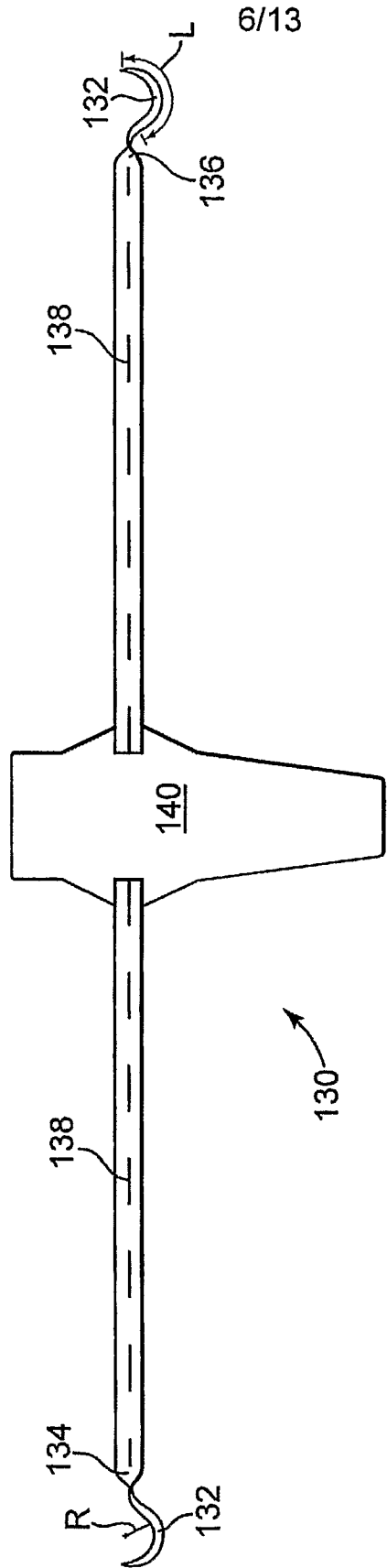

Fig. 5

7/13

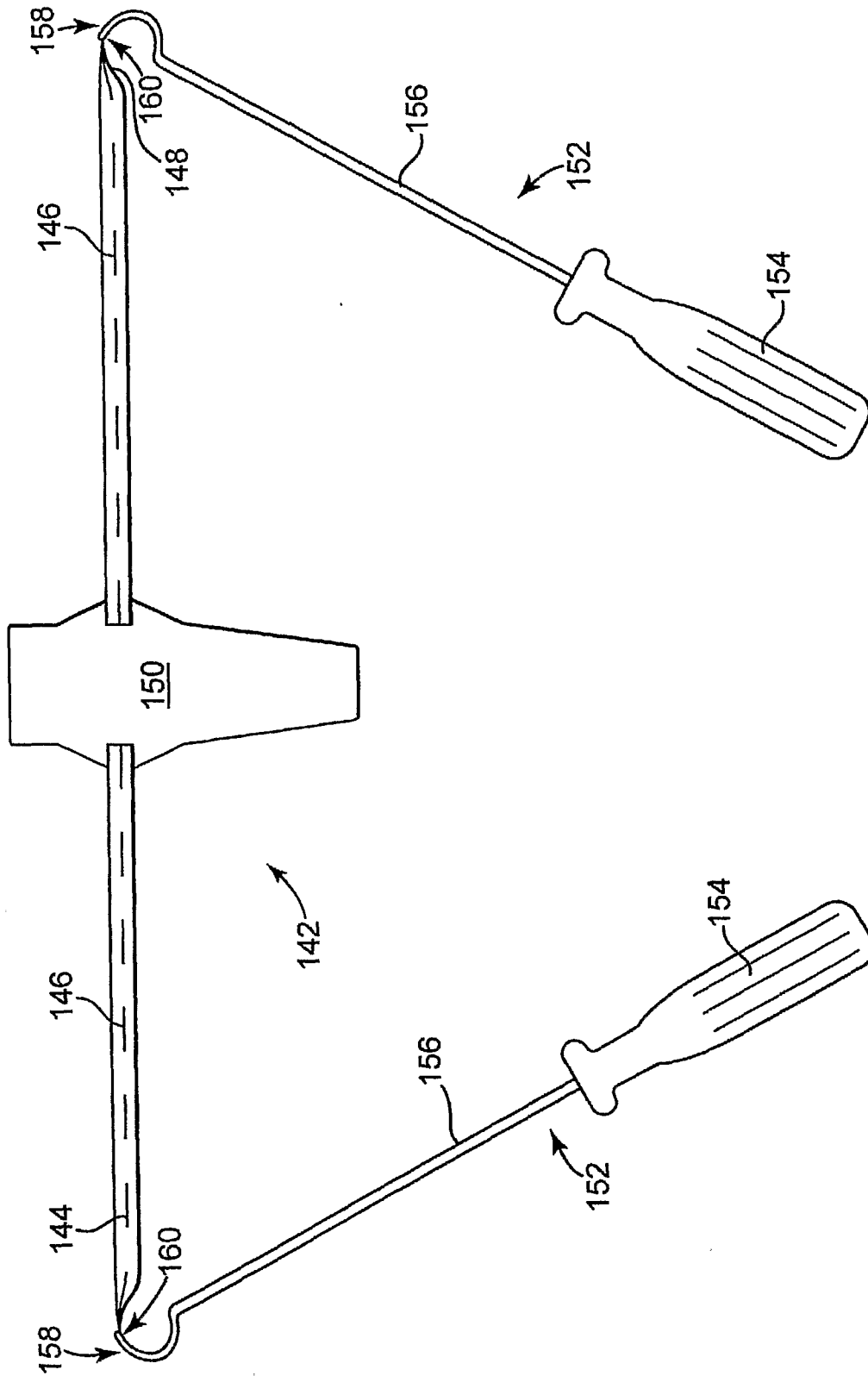

Fig. 6

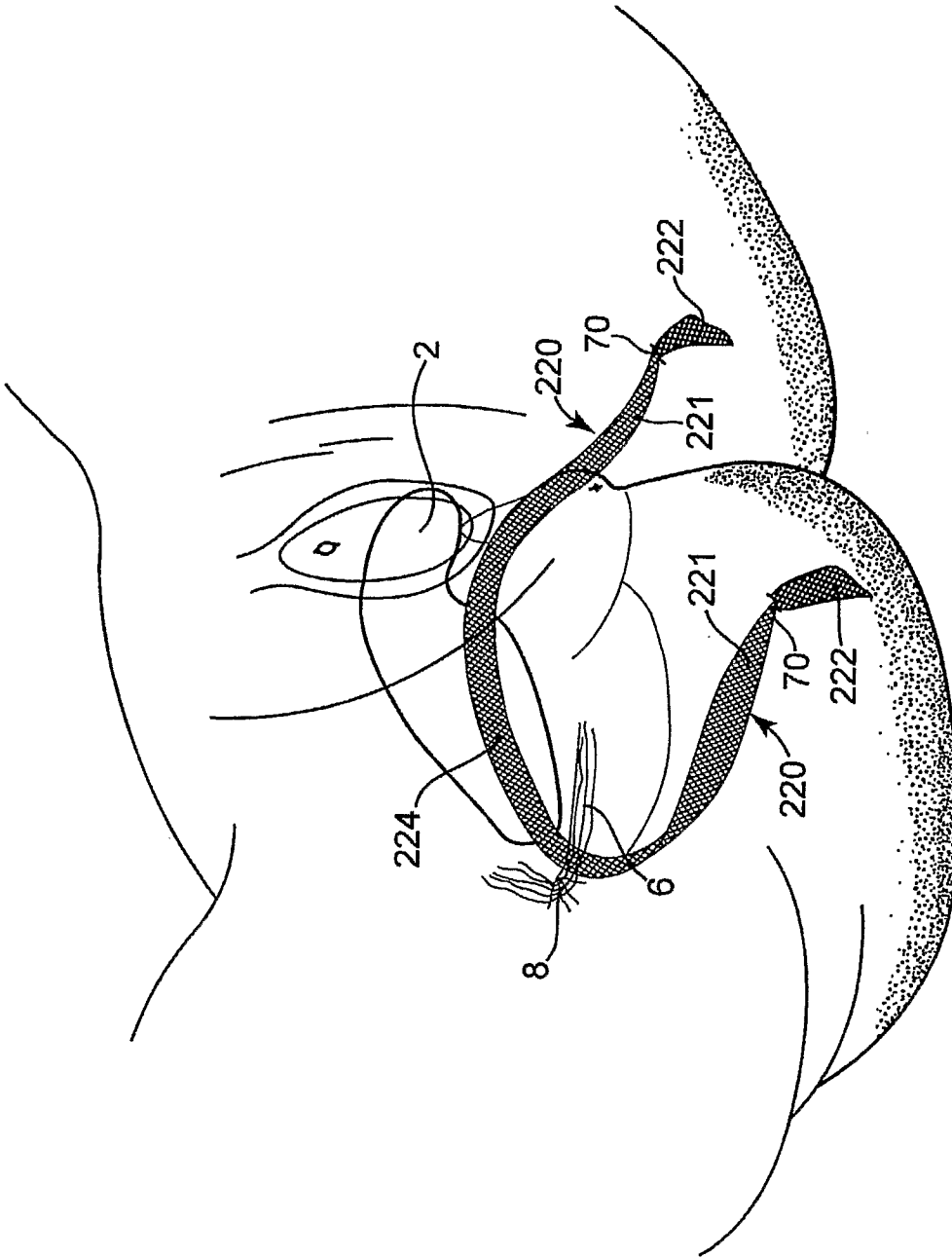

Fig. 7

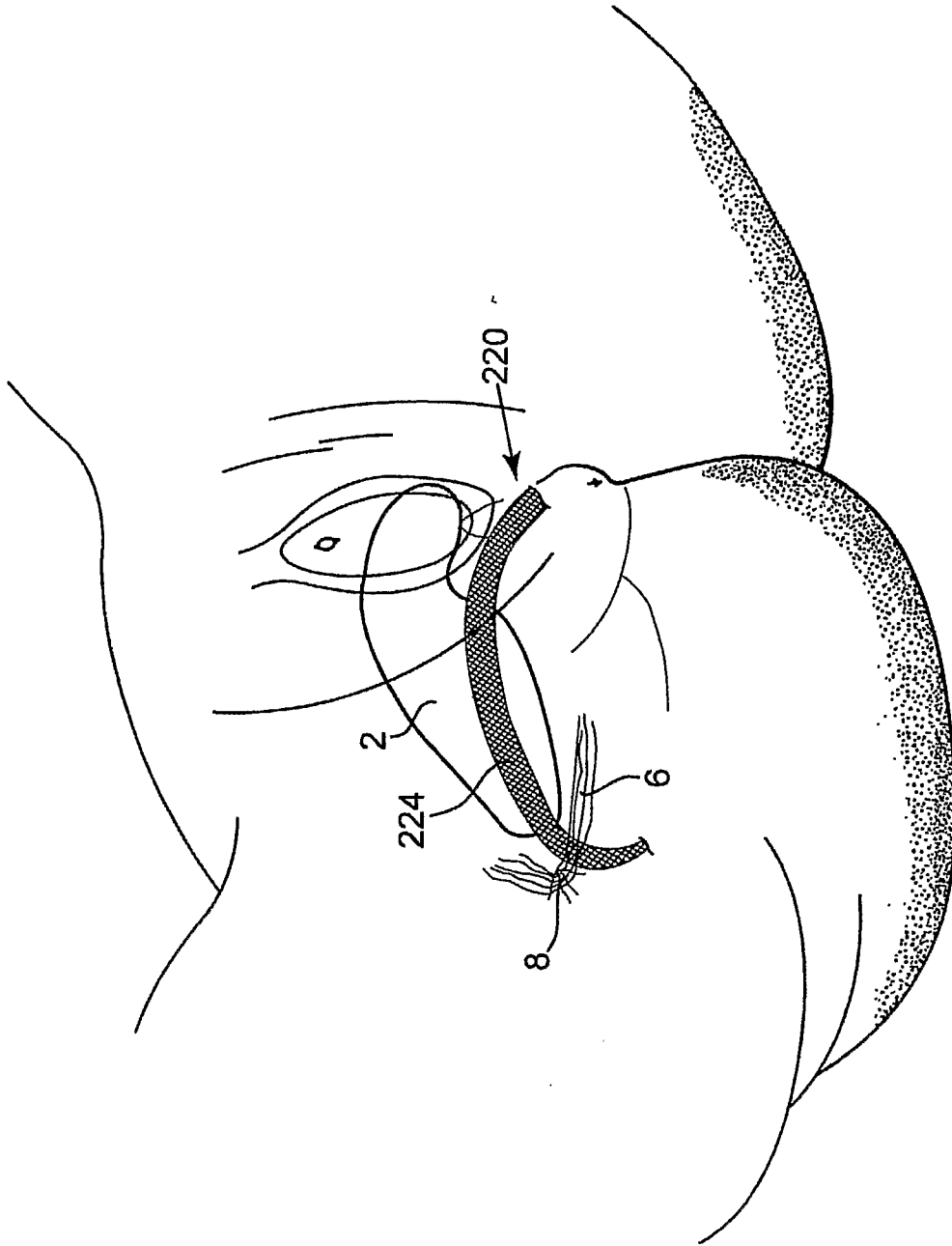

Fig. 7A

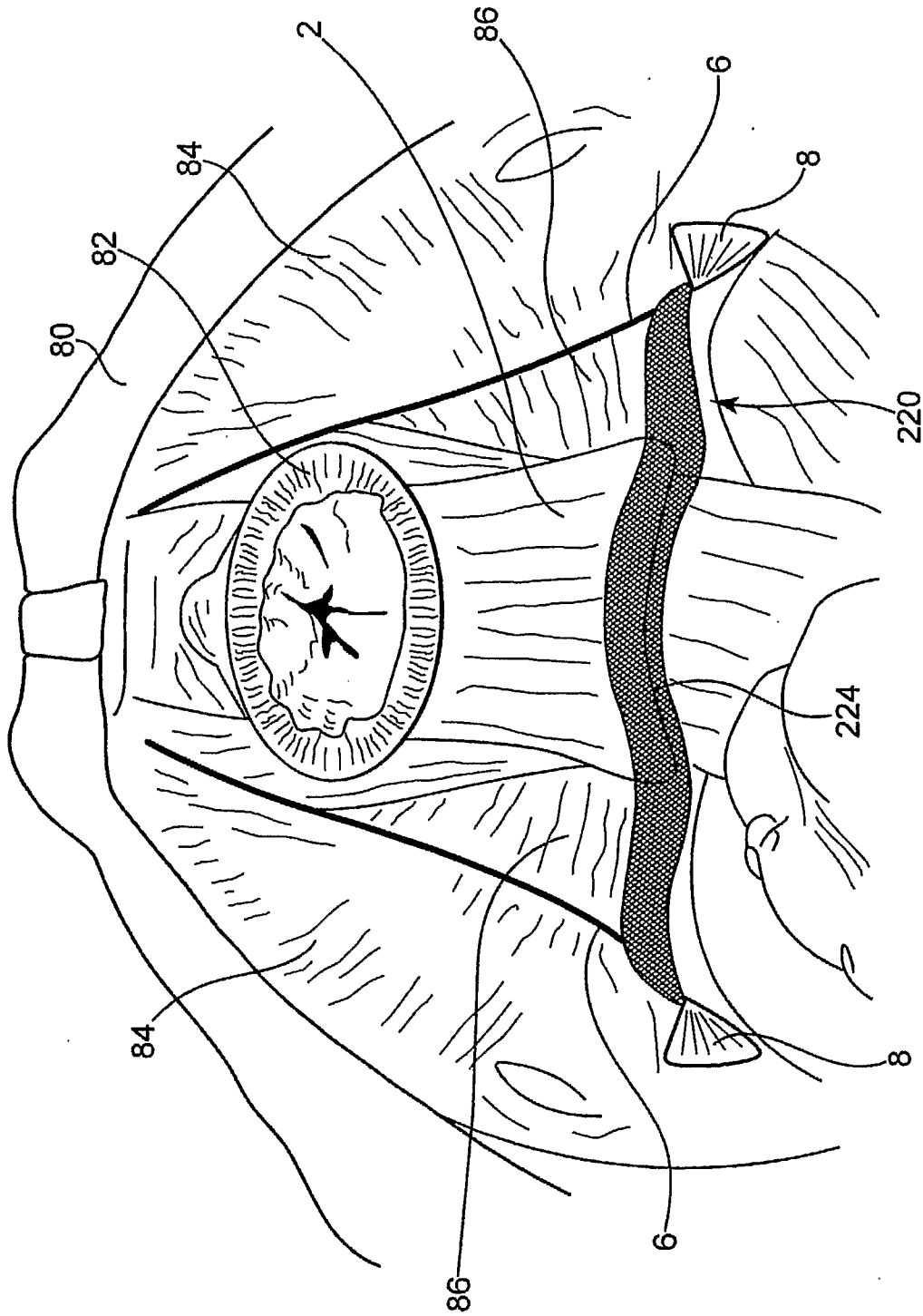

Fig. 8

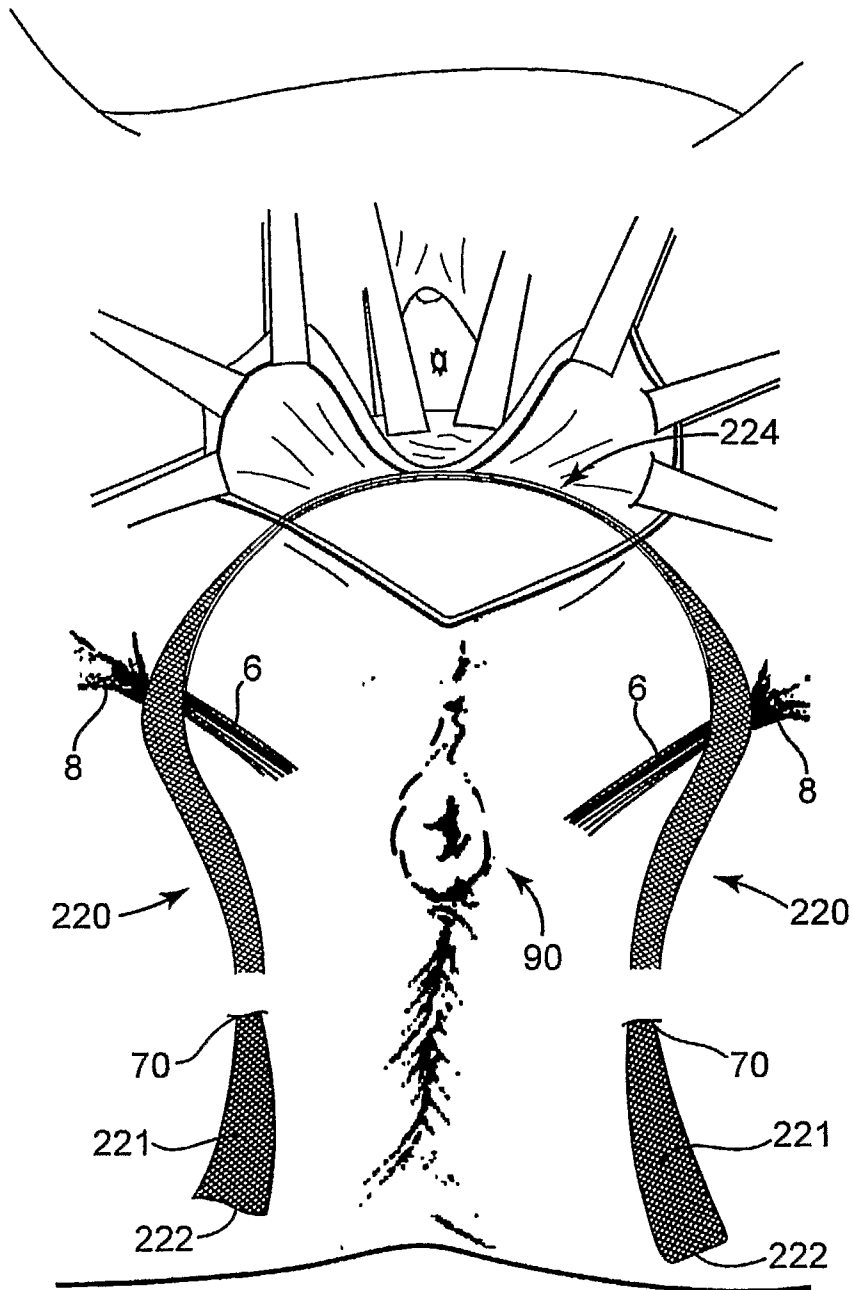

Fig. 9

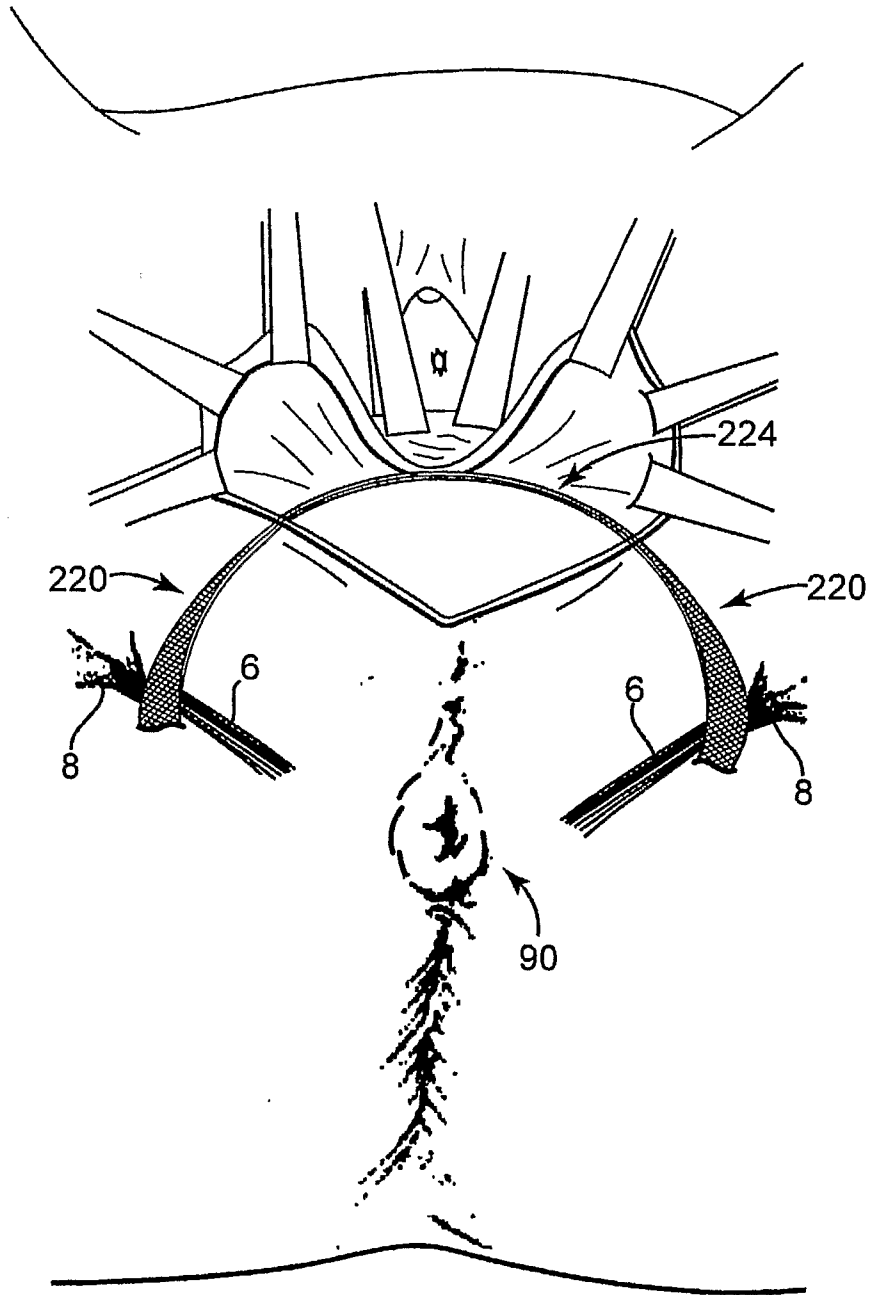

Fig. 9A

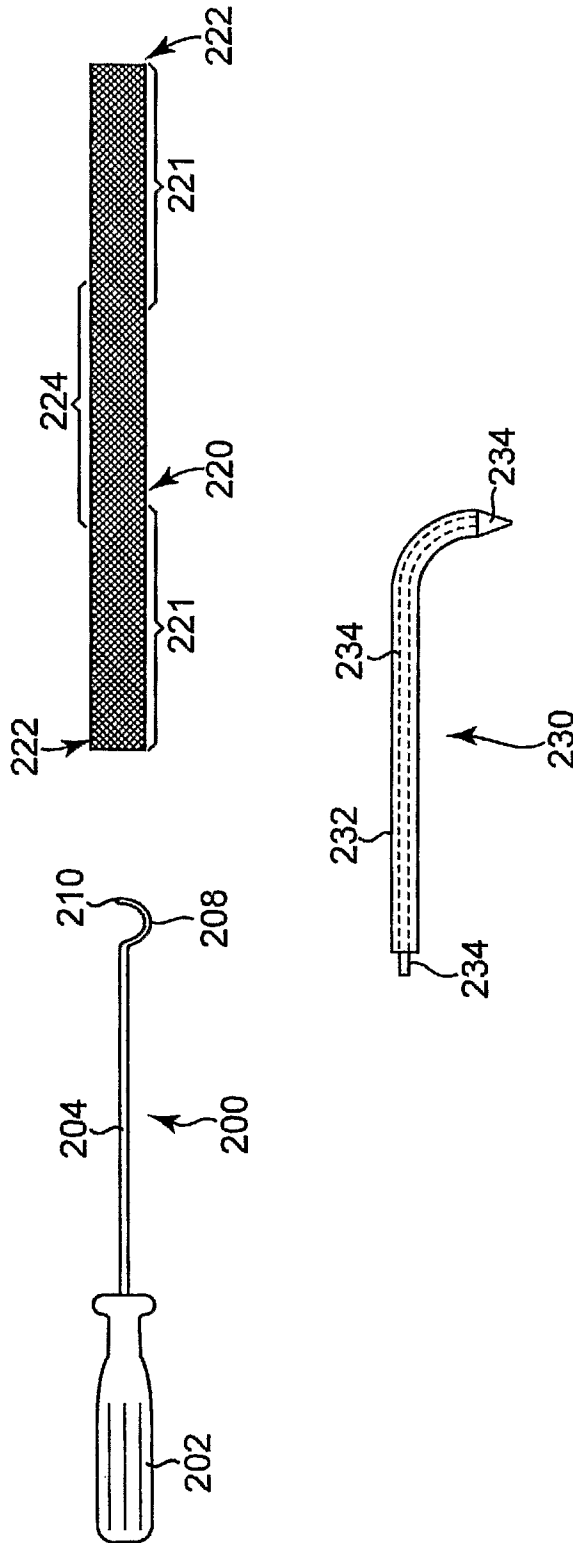

Fig. 10

INTERNATIONAL SEARCH REPORT

International application No

PCT/US2006/028828

A. CLASSIFICATION OF SUBJECT MATTER
 INV. A61F2/00 A61B17/04

According to International Patent Classification (IPC) or to both national classification and IPC

B. FIELDS SEARCHED

Minimum documentation searched (classification system followed by classification symbols)
 A61F A61B

Documentation searched other than minimum documentation to the extent that such documents are included in the fields searched

Electronic data base consulted during the international search (name of data base and, where practical, search terms used)

EPO-Internal

C. DOCUMENTS CONSIDERED TO BE RELEVANT

Category*	Citation of document, with indication, where appropriate, of the relevant passages	Relevant to claim No.
X A	WO 00/74594 A (ETHICON INC [US]) 14 December 2000 (2000-12-14) page 9, line 26 - page 11, line 8; figures 3,4	10, 19 11, 17, 18, 20
X A	US 2005/000523 A1 (BERAUD JEAN-MARC [FR]) 6 January 2005 (2005-01-06) paragraphs [0045] - [0047], [0058], [0059]; figures	10 11-20



Further documents are listed in the continuation of Box C.



See patent family annex.

* Special categories of cited documents :

A document defining the general state of the art which is not considered to be of particular relevance

E earlier document but published on or after the international filing date

L document which may throw doubts on priority claim(s) or which is cited to establish the publication date of another citation or other special reason (as specified)

O document referring to an oral disclosure, use, exhibition or other means

P document published prior to the international filing date but later than the priority date claimed

T later document published after the international filing date or priority date and not in conflict with the application but cited to understand the principle or theory underlying the invention

X document of particular relevance; the claimed invention cannot be considered novel or cannot be considered to involve an inventive step when the document is taken alone

Y document of particular relevance; the claimed invention cannot be considered to involve an inventive step when the document is combined with one or more other such documents, such combination being obvious to a person skilled in the art.

& document member of the same patent family

Date of the actual completion of the international search

20 November 2006

Date of mailing of the international search report

24/11/2006

Name and mailing address of the ISA/

European Patent Office, P.B. 5818 Patentlaan 2
 NL - 2280 HV Rijswijk
 Tel. (+31-70) 340-2040, Tx. 31 651 epo nl,
 Fax: (+31-70) 340-3016

Authorized officer

Neumann, Elisabeth

INTERNATIONAL SEARCH REPORT

International application No
PCT/US2006/028828

C(Continuation). DOCUMENTS CONSIDERED TO BE RELEVANT		
Category*	Citation of document, with indication, where appropriate, of the relevant passages	Relevant to claim No.
X	WO 03/096928 A (SOFRADIM PRODUCTION [FR]; THERIN MICHEL [FR]) 27 November 2003 (2003-11-27) page 4, line 22 - line 31; figures page 7, line 20 - page 8, line 22	10
A	-----	11,12, 14-20
X	WO 02/28312 A (SOFRADIM PRODUCTION [FR]; THERIN MICHEL [FR]) 11 April 2002 (2002-04-11) page 4, line 3 - line 16; figures	10
A	-----	17,19

INTERNATIONAL SEARCH REPORT

International application No.
PCT/US2006/028828

Box II Observations where certain claims were found unsearchable (Continuation of item 2 of first sheet)

This International Search Report has not been established in respect of certain claims under Article 17(2)(a) for the following reasons:

1. Claims Nos.: 1-9
because they relate to subject matter not required to be searched by this Authority, namely:
Rule 39.1(iv) PCT - Method for treatment of the human or animal body by surgery
2. Claims Nos.:
because they relate to parts of the International Application that do not comply with the prescribed requirements to such an extent that no meaningful International Search can be carried out, specifically:
3. Claims Nos.:
because they are dependent claims and are not drafted in accordance with the second and third sentences of Rule 6.4(a).

Box III Observations where unity of invention is lacking (Continuation of item 3 of first sheet)

This International Searching Authority found multiple inventions in this international application, as follows:

1. As all required additional search fees were timely paid by the applicant, this International Search Report covers all searchable claims.
2. As all searchable claims could be searched without effort justifying an additional fee, this Authority did not invite payment of any additional fee.
3. As only some of the required additional search fees were timely paid by the applicant, this International Search Report covers only those claims for which fees were paid, specifically claims Nos.:
4. No required additional search fees were timely paid by the applicant. Consequently, this International Search Report is restricted to the invention first mentioned in the claims; it is covered by claims Nos.:

Remark on Protest

- The additional search fees were accompanied by the applicant's protest.
- No protest accompanied the payment of additional search fees.

INTERNATIONAL SEARCH REPORT

Information on patent family members

International application No

PCT/US2006/028828

Patent document cited in search report	Publication date	Patent family member(s)	Publication date
WO 0074594	A	14-12-2000	AU 775053 B2 15-07-2004
			AU 4710500 A 28-12-2000
			BR 0011726 A 05-08-2003
			CA 2376278 A1 14-12-2000
			CN 1433288 A 30-07-2003
			EP 1200011 A1 02-05-2002
			JP 2003523786 T 12-08-2003
			US 6273852 B1 14-08-2001
			US 2002077526 A1 20-06-2002
			US 2001049467 A1 06-12-2001
US 2005000523	A1	06-01-2005	EP 1475045 A1 10-11-2004
			FR 2852813 A1 01-10-2004
WO 03096928	A	27-11-2003	AT 322227 T 15-04-2006
			AU 2003249415 A1 02-12-2003
			CN 1655736 A 17-08-2005
			EP 1505928 A1 16-02-2005
			ES 2259145 T3 16-09-2006
			JP 2005529643 T 06-10-2005
WO 0228312	A	11-04-2002	AT 311831 T 15-12-2005
			AU 9564601 A 15-04-2002
			DE 60115705 T2 17-08-2006
			EP 1339347 A1 03-09-2003
			ES 2254498 T3 16-06-2006
			FR 2814939 A1 12-04-2002
			HK 1059726 A1 18-08-2006
			JP 3776083 B2 17-05-2006
			JP 2004510489 T 08-04-2004
			US 2003004395 A1 02-01-2003