



(86) Date de dépôt PCT/PCT Filing Date: 2010/09/03  
 (87) Date publication PCT/PCT Publication Date: 2011/03/10  
 (85) Entrée phase nationale/National Entry: 2012/01/18  
 (86) N° demande PCT/PCT Application No.: EP 2010/062925  
 (87) N° publication PCT/PCT Publication No.: 2011/026929  
 (30) Priorités/Priorities: 2009/09/04 (US61/240,063);  
 2009/09/04 (EP09169510.6)

(51) Cl.Int./Int.Cl. *A61M 25/01* (2006.01)  
 (71) Demandeur/Applicant:  
 ASTRA TECH AB, SE  
 (72) Inventeur/Inventor:  
 FROEJD, GOERAN, SE  
 (74) Agent: FETHERSTONHAUGH & CO.

(54) Titre : CATHETER AVEC CONNECTEUR PERSONNALISABLE  
 (54) Title: CATHETER WITH CUSTOMIZABLE CONNECTOR

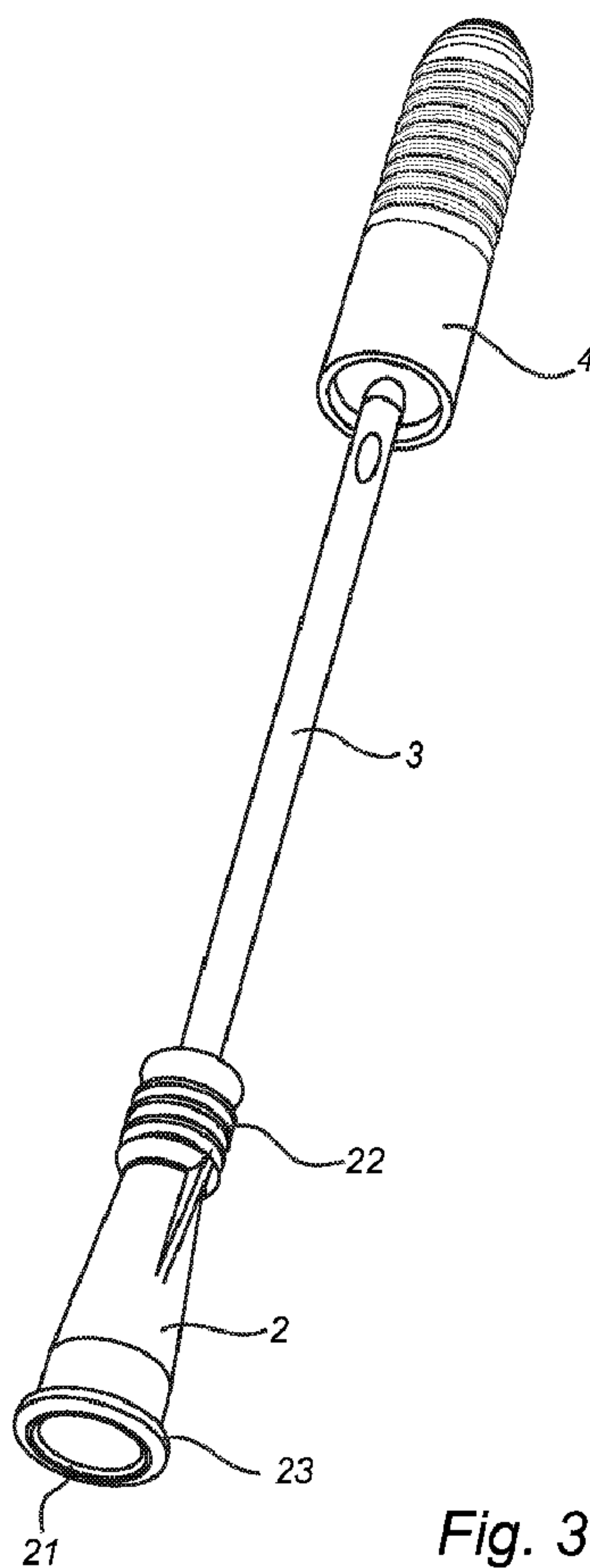

Fig. 3

(57) Abrégé/Abstract:

A catheter, and preferably a urinary catheter, is disclosed, comprising an elongate shaft (3) with a catheter insertion end and a flared connector (2) connected to the elongated shaft opposite to the catheter insertion end. The flared connector forms a catheter

(57) **Abrégé(suite)/Abstract(continued):**

connector end (21). Further, a gripping sleeve (4) is fixedly connected to the flared connector, and arranged to enclose at least part of, and preferably essentially the whole, flared connector, apart from the catheter connector end. Hereby, a standard catheter can easily be customized for various use situations and users with different needs, in terms of e.g. gripping and manipulation possibilities. A method for producing such a customized catheter is also disclosed.

(12) INTERNATIONAL APPLICATION PUBLISHED UNDER THE PATENT COOPERATION TREATY (PCT)

(19) World Intellectual Property Organization  
International Bureau(43) International Publication Date  
10 March 2011 (10.03.2011)(10) International Publication Number  
**WO 2011/026929 A1**(51) International Patent Classification:  
*A61M 25/01* (2006.01)(71) Applicant (for all designated States except US): **ASTRA  
TECH AB** [SE/SE]; Aminogatan 1, S-431 21 Mölndal  
(SE).(21) International Application Number:  
PCT/EP2010/062925

(72) Inventor; and

(22) International Filing Date:  
3 September 2010 (03.09.2010)(75) Inventor/Applicant (for US only): **FRÖJD, Göran**  
[SE/SE]; Smörgatan 78, S-412 76 Göteborg (SE).

(25) Filing Language: English

(74) Agent: **LIND, Urban**; P.O. Box 11394, S-404 28 Göte-  
borg (SE).

(26) Publication Language: English

(30) Priority Data:  
09169510.6 4 September 2009 (04.09.2009) EP  
61/240,063 4 September 2009 (04.09.2009) US(81) Designated States (unless otherwise indicated, for every  
kind of national protection available): AE, AG, AL, AM,  
AO, AT, AU, AZ, BA, BB, BG, BH, BR, BW, BY, BZ,  
CA, CH, CL, CN, CO, CR, CU, CZ, DE, DK, DM, DO,  
DZ, EC, EE, EG, ES, FI, GB, GD, GE, GH, GM, GT,  
HN, HR, HU, ID, IL, IN, IS, JP, KE, KG, KM, KN, KP,  
KR, KZ, LA, LC, LK, LR, LS, LT, LU, LY, MA, MD,

[Continued on next page]

(54) Title: CATHETER WITH CUSTOMIZABLE CONNECTOR

(57) Abstract: A catheter, and preferably a urinary catheter, is disclosed, comprising an elongate shaft (3) with a catheter insertion end and a flared connector (2) connected to the elongate shaft opposite to the catheter insertion end. The flared connector forms a catheter connector end (21). Further, a gripping sleeve (4) is fixedly connected to the flared connector, and arranged to enclose at least part of, and preferably essentially the whole, flared connector, apart from the catheter connector end. Hereby, a standard catheter can easily be customized for various use situations and users with different needs, in terms of e.g. gripping and manipulation possibilities. A method for producing such a customized catheter is also disclosed.

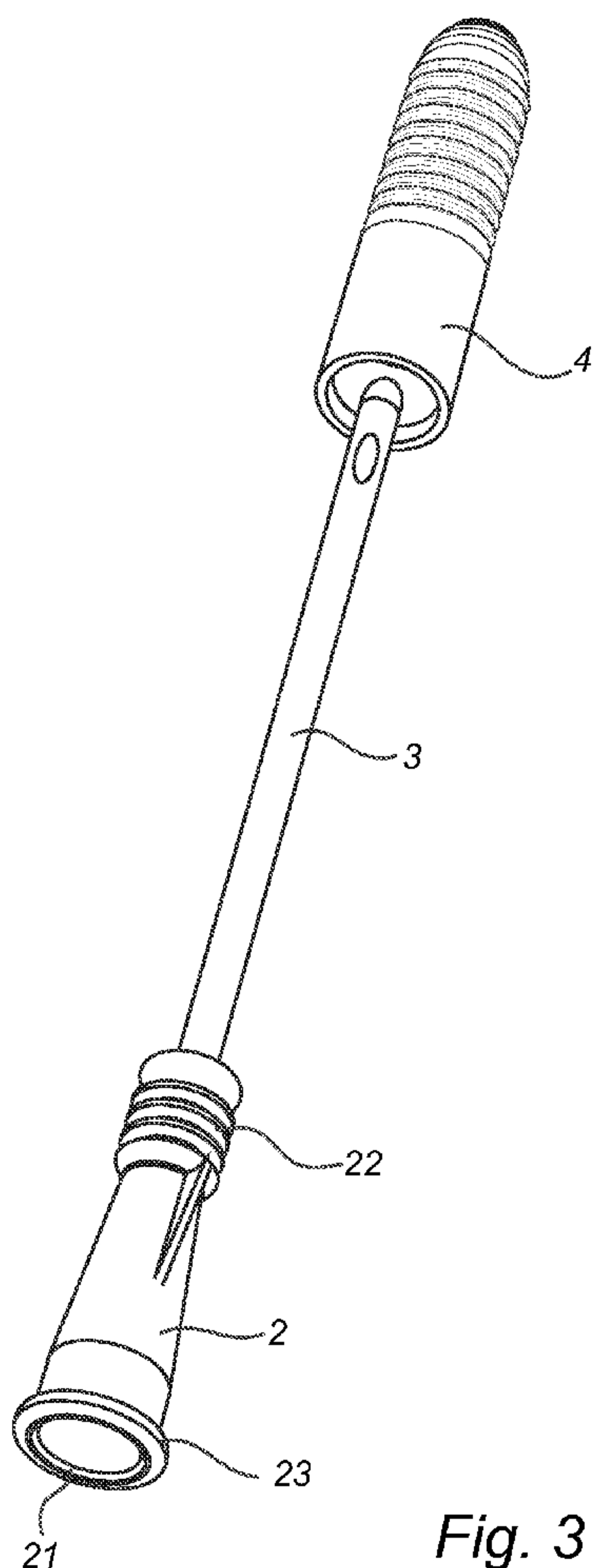

Fig. 3

  
WO 2011/026929 A1

**WO 2011/026929 A1** 

ME, MG, MK, MN, MW, MX, MY, MZ, NA, NG, NI, NO, NZ, OM, PE, PG, PH, PL, PT, RO, RS, RU, SC, SD, SE, SG, SK, SL, SM, ST, SV, SY, TH, TJ, TM, TN, TR, TT, TZ, UA, UG, US, UZ, VC, VN, ZA, ZM, ZW.

**(84) Designated States** (unless otherwise indicated, for every kind of regional protection available): ARIPO (BW, GH, GM, KE, LR, LS, MW, MZ, NA, SD, SL, SZ, TZ, UG, ZM, ZW), Eurasian (AM, AZ, BY, KG, KZ, MD, RU, TJ, TM), European (AL, AT, BE, BG, CH, CY, CZ, DE, DK, EE, ES, FI, FR, GB, GR, HR, HU, IE, IS, IT, LT, LU, LV, MC, MK, MT, NL, NO, PL, PT, RO, SE, SI, SK,

SM, TR), OAPI (BF, BJ, CF, CG, CI, CM, GA, GN, GQ, GW, ML, MR, NE, SN, TD, TG).

**Declarations under Rule 4.17:**

— as to applicant's entitlement to apply for and be granted a patent (Rule 4.17(ii))

**Published:**

— with international search report (Art. 21(3))

## CATHETER WITH CUSTOMIZABLE CONNECTOR

### Technical field of the invention

The present invention relates to a catheter, such as urinary catheters,  
5 and in particular to catheters of a relatively short length, such as female  
catheters.

### Background

The present invention relates to a catheter for draining bodily fluids,  
10 e.g. from the bladder. Urinary catheters are e.g. used by a large group of  
persons for intermittent catheterization, which is a daily-life procedure, taking  
place several times a day. Typically catheters for intermittent catheterization  
are used by patients suffering from urinary incontinence or by disabled  
15 individuals like para- or tetraplegics. Using an intermittent catheter, the  
bladder may be drained through a natural or artificial urethra. Many catheters  
for intermittent catheterization are provided with a hydrophilic coating or the  
like, providing a smooth and slippery surface for safe and comfortable  
insertion in the urinary canal.

To this end, catheters should preferably be designed to enable easy  
20 handling and introduction into the urethra, even for users having reduced  
dexterity. Further, in order to reduce the risk of e.g. urinary tract infections,  
the catheters should preferably be handled in a clean manner, without directly  
touching the insertable part of the catheter with the hands, in order to avoid  
contamination prior to use.

25 Catheters, such as urinary catheters, are normally produced in large  
volumes, having standardized lengths and standardized connector designs.  
However, it is sometimes requested to have large connector ends, in  
particular for short, female catheters, in order to improve maneuverability.  
However, provision of large assortment of different catheters, having different  
30 connector lengths, connector designs, catheter lengths, etc, makes the

production costly. Typically catheters are designed for one-time use and accordingly the costs for producing, packing and sterilizing a catheter is an important issue. There is therefore a need for a simple and cost-effective way of modifying a pre-produced standard catheter to various specific needs, such as improved gripping possibilities.

An alternative approach to obtain improved usability of catheters is disclosed in US 2005/0070882, which discloses a urinary catheter with a cuff loosely arranged over the connector end. This loosely arranged cuff can be moved along the catheter, for use when handling the catheter. However, this approach requires a relatively skilled user, and is e.g. complicated to for users with reduced dexterity, and is also difficult to use with short catheters, such as female urinary catheters.

Further, US 2007/0066963 discloses a catheter assembly comprising a detachable catheter handle, which is connected to the rearward end of the catheter before use, in order to provide an enlarged handle for easier manipulation. Still further, US 2006/0142737 discloses a catheter assembly, including a catheter with a long connector end, for improved manipulation. However, both these prior art solutions are related to relatively complex catheter products, which are difficult and expensive to produce.

In other products the contamination problem of the handle portion has been addressed by providing a handle formed separately from the catheter for attachment to the catheter prior to the insertion. Unfortunately, handles which are separate from the catheter imply other problems both with respect to the manufacturing costs and with respect to handling of two separate components when attaching the handle to the catheter. In addition, separation of the catheter into two separate components implies an increased risk of contamination, in particular, if the handle part is reused. Furthermore, division of the catheter into a handle part separate from an insertable part does not solve the problems of complicated unpacking.

In conclusion there is still a need for catheters, which may be designed for simple and clean use, even for users with a reduced dexterity, and which can be produced in a cost-efficient manner.

Summary of the invention

It is therefore an object of the present invention to provide a catheter, and a method of producing such a catheter, which at least alleviates the above-discussed problems.

5 This object is obtained by means of a catheter and a method of producing in accordance with the appended claims.

According to a first aspect of the invention there is provided a catheter, and preferably a urinary catheter, comprising an elongate shaft with a catheter insertion end and a flared connector connected to the elongated  
10 shaft opposite to the catheter insertion end, the flared connector forming a catheter connector end; and a gripping sleeve being fixedly connected to said flared connector, and arranged to enclose at least a part of, and preferably essentially the whole, flared connector, apart from the catheter connector end.

15 By “fixedly connected” is in this context to understand a connection which is not intended to be opened during normal use. It does not necessarily mean that the fixedly connected parts may not be separated, but that the connection is strong enough to ensure that such separation does not occur during normal use. The fixed connection can be obtained in various ways,  
20 such as by friction fit, adhesion, mechanical interlocking and the like.

Hereby, it becomes possible to produce large series of catheters having standardized lengths and standardized flared connectors. The connector is preferably a relatively short conical connector part e.g. for connecting the catheter to elongate tubes or drainage containers for collecting  
25 urine. The connector also serves as a manipulation aid, and by gripping the connector, the catheter may be manipulated and inserted into the urinary canal (urethra).

Thus, the catheter without any gripping sleeve in itself is a catheter which is adequate for many use situations.

30 However, for customization, and simple production of other types of catheter products, the same, standard catheter may be used, and be completed with a gripping sleeve. Hereby, an extended and enlarged aggregate connector is provided. Such an enlarged gripping portion is highly

advantageous in many situations, such as in products to be used by users with reduced dexterity, short catheters, where other types of insertion aids are difficult to use, etc. Thus, a catheter according to the present invention is particularly advantageous for short catheters, used e.g. by females, children  
5 or persons with an artificial urinary canal. In one embodiment of the invention the catheter is adapted to fit the female urethra, i.e. it may be provided in a length in the range of 50-200 mm, such as 130-180 mm, such as in a length in the size of 150 mm.

Further, the sleeve does preferably not extend past the rearward end  
10 of the catheter. Hereby, the ordinary handling of the catheter, e.g. connecting it to additional tubing or a urine collection bag, is not in any way affected.

By means of the present invention, it is possible to use the same production equipment for a large variety of different catheter products, which makes the production very cost-efficient. Further, it becomes possible to react  
15 quickly to market demands, and introduce specialized catheters for various types of specific use.

Preferably the gripping sleeve has an axial length significantly longer than the axial length of the flared connector. For example, the gripping sleeve may have an axial length which is at least 25% longer than the axial length of  
20 the flared connector, and preferably at least 50% longer. It is also preferred that the gripping sleeve has an axial length of at least 4 cm, and preferably at least 5 cm.

The catheter may be any type of catheter, but in a preferred embodiment the catheter is a urinary catheter.

25 The gripping sleeve is preferably connected to the flared connector end by means of a friction fit (i.e. press fit) or mechanical interlocking. This way of connecting the gripping sleeve makes the production very simple and cost-efficient. Alternatively or additionally, the gripping sleeve may be connected to the flared connector by means of at least one of welding and  
30 adhesion.

In order to further enhance the attachment of the gripping sleeve to the flared connector, the flared connector is preferably provided with an outwardly

5

facing corrugation, and the gripping sleeve is preferably provided with a corresponding inwardly facing corrugation.

The outer surface of the gripping sleeve may be provided with various means for improve the gripping and handling. Thus, the gripping sleeve may  
5 be ergonomically shaped to make it easier to manipulate, especially for persons with reduced dexterity. For example, the gripping sleeve may be provided with an outwardly facing corrugation. The gripping sleeve may also be provided with outwardly protruding gripping means, such as wings. Other types of protruding parts, such as grooves, rugged surfaces, finger holes, etc,  
10 are also feasible.

The invention is particularly useful for hydrophilic catheters, i.e. catheters having a hydrophilic surface coating on part or the whole of the exterior surface of the elongate shaft.

Further, it is preferred that the flared connector comprises an outwardly  
15 protruding flange in the vicinity of the catheter connector end, said flange providing an abutment for the gripping sleeve. Hereby, the attachment of the gripping sleeve is improved, and further, it is ensured that the gripping sleeve does not protrude past the end of the flared connector.

According to a further aspect of the invention, there is provided a  
20 method of producing a customized catheter, and preferably a urinary catheter, comprising the steps of:

providing a base catheter comprising an elongate shaft and a flared connector with a catheter connector end connected to one end of said elongate shaft; and

25 arranging a customizable gripping sleeve over said flared connector, to enclose at least a part of, and preferably essentially the whole, flared connector, apart from the catheter connector end, and fixedly connecting the gripping sleeve to said flared connector.

Hereby, similar advantages as discussed above with reference to the  
30 first aspect of the invention are obtained.

The method further preferably comprises the step of selecting a suitable gripping sleeve among a plurality of available gripping sleeves. Preferably, a plurality of different gripping sleeves are provided, and used on

6

common base catheters to form a plurality of different catheters. Hereby, it becomes possible to provide a number of various gripping sleeve, corresponding to a number of different catheters, and to produce said different catheters in the same line of manufacturing.

5           These and other aspects of the invention will be apparent from and elucidated with reference to the embodiments described hereinafter.

#### Brief description of the drawings

10           For exemplifying purposes, the invention will be described in closer detail in the following with reference to embodiments thereof illustrated in the attached drawings, wherein:

Fig 1 illustrates a catheter in accordance with an embodiment of the present invention;

Fig 2 illustrates a part of the catheter of Fig 1, partially in section; and

15           Fig 3 illustrates an intermediate step in the assembly of the catheter of Fig 1.

#### Description of preferred embodiments

20           In the following detailed description preferred embodiments of the invention will be described. However, it is to be understood that features of the different embodiments are exchangeable between the embodiments and may be combined in different ways, unless anything else is specifically indicated. It may also be noted that, for the sake of clarity, the dimensions of certain components illustrated in the drawings may differ from the  
25           corresponding dimensions in real-life implementations of the invention, e.g. the length of the catheter, etc.

30           Catheters may be used for many different purposes, and for insertion into various types of body-cavities. However, the following discussion is in particular concerned with the preferred field of use, hydrophilic urinary catheters, even though the invention is not limited to this particular type of catheters.

A catheter 1 as illustrated in the drawings, e.g. in Fig. 3, comprises a flared rearward portion, forming a flared connector 2, and an elongated shaft

3, connected to the flared connector 2, and in the opposite end having a catheter insertion end 31. The flared connector 2 forms a catheter connector end 21.

5 An open-ended internal lumen (not shown) extends from the catheter connector end 21 to a drainage aperture 32 in a rounded tip 33 of the elongate tube 3.

10 The flared connector 2 may function as a connector of the catheter 1, being connectable to other devices, such as a urine collection bag, a drainage tube or the like. It may have any size and form, forming a flared extension in relation to the elongate shaft, as is per se well known in the art. Further, the flared connector 2 may be connected to the elongate shaft 3 by means of welding, adhesion or the like, or form an integrated part of the elongate shaft.

15 At least a part of the elongate shaft 3 forms an insertable length to be inserted through a body opening of the user, such as the urethra in case of a urinary catheter. By insertable length is normally, in the context of a hydrophilic catheter, meant that length of the elongate shaft 3 which is coated with a hydrophilic material, for example PVP, and which is insertable into the urethra of the patient. Typically, this will be 50-140 mm for a female patient and 200-350 mm for a male patient. Even though PVP is the preferred  
20 hydrophilic material, other hydrophilic materials may be used, such as hydrophilic polymers selected from polyvinyl compounds, polysaccharides, polyurethanes, polyacrylates or copolymers of vinyl compounds and acrylates or anhydrides, especially polyethyleneoxide, polyvinyl-pyrrolidone, heparin, dextran, xanthan gum, polyvinyl alcohol, hydroxy propyl cellulose, methyl  
25 cellulose, copolymer of vinylpyrrolidone and hydroxy ethylmethyl acrylate or copolymer of polymethylvinyl ether and maleinic acid anyhydride. The coating may also comprise an osmolality-increasing compound, as is e.g. taught in EP 0 217 771

30 In addition, the catheter comprises a gripping sleeve 4 surrounding and being fixedly connected to the flared connector 2, and arranged to enclose essentially the whole flared connector, apart from the catheter connector end 21.

The gripping sleeve 4 preferably has an axial length significantly longer than the axial length of the flared connector 2.

The gripping sleeve is preferably connected to the flared connector end by means of a friction fit. Alternatively or additionally, the gripping sleeve  
5 may be connected to the flared connector by means of at least one of welding and adhesion. In order to further enhance the attachment of the gripping sleeve to the flared connector, the flared connector 2 is preferably provided with an outwardly facing corrugation 22, and the gripping sleeve 4 is  
10 preferably provided with a corresponding inwardly facing corrugation 41. Further, it is preferred that the flared connector 2 comprises an outwardly protruding flange 23 in the vicinity of the catheter connector end, providing an abutment for the gripping sleeve 4.

The gripping sleeve is a tubular part, with a first opening with an inward diameter preferably essentially corresponding with the corresponding external  
15 diameter of the flared connector, and a second opening with an inward diameter preferably corresponding with the corresponding external diameter of the elongate shaft. The gripping sleeve preferably has a cylindrical shape, and it could be circular or non-circular in a cross-sectional view.

The outer surface of the gripping sleeve 4 may be provided with  
20 various means for improve the gripping and handling. For example, the gripping sleeve may be provided with an outwardly facing corrugation 42. The gripping sleeve may also be provided with outwardly protruding gripping means, such as wings (not shown).

The catheter components can be made from a large number of  
25 feasible materials, as is per se well known in the art. The elongate shaft, the flared connector and the gripping sleeve may further be made of the same material, or by two or more different materials. In the latter case, the parts may be made from materials with different characteristics towards softness and/or rigidity. The gripping sleeve may e.g. be made from a low frictional  
30 material, or it may have a surface coating preventing sliding between the fingers of the user, or it may have a surface pattern facilitating a better grip. The gripping sleeve could be made from a material which is rigid compared to the insertable part of the catheter.

The various catheter parts, or at least a part of one or several of said parts, could be made from a thermoplastic elastomer or other thermoplastic materials, or from a curable elastomer material, or from any mixture or combination thereof. Thermoplastic elastomer materials may comprise  
5 materials like polyurethane elastomers, polyetherblockamide elastomers, polyester elastomers, polyolefin elastomers and polystyrene elastomers and SEBS. Other thermoplastic materials may comprise PVC, e.g. plasticized PVC, polyethylene homo- or co-polymers, polypropylene homo- or co-  
10 polymers, polyamide types, polyester types, fluorine-containing thermoplastic materials such as fluorine-containing elastomers among others. Curable elastomer material may comprise silicone elastomers and curable polyurethane elastomers among others. Latex rubbers and other rubbers are also feasible.

Each of the parts can be made e.g. by extrusion, injection moulding,  
15 blow moulding etc.

A method of manufacturing the above-discussed catheter preferably comprises the steps of first producing a base catheter comprising an elongate shaft and a flared connector with a catheter connector end connected to one end of said elongate shaft, as is per se known in the art. Subsequently, the  
20 gripping sleeve is arranged over the flared connector, to enclose essentially the whole flared connector, apart from the catheter connector end, and fixedly connecting the gripping sleeve to said flared connector. This is illustrated in Fig 3.

The invention has now been described by means of preferred  
25 embodiments. However, many further variations are possible. For example, the gripping sleeve may be attached to the flared connector in other ways, such as by means of mechanical interlocking, the gripping sleeve may be provided with various forms of external gripping means, etc. Such and other obvious modifications must be considered to be within the scope of the  
30 present invention, as it is defined by the appended claims. It should be noted that the above-mentioned embodiments illustrate rather than limit the invention, and that those skilled in the art will be able to design many alternative embodiments without departing from the scope of the appended

claims. In the claims, any reference signs placed between parentheses shall not be construed as limiting to the claim. The word "comprising" does not exclude the presence of other elements or steps than those listed in the claim. The word "a" or "an" preceding an element does not exclude the  
5 presence of a plurality of such elements. Further, a single unit may perform the functions of several means recited in the claims.

## CLAIMS

1. A catheter, and preferably a urinary catheter, comprising an elongate shaft with a catheter insertion end and a flared connector connected  
5 to the elongated shaft opposite to the catheter insertion end, the flared connector forming a catheter connector end; and a gripping sleeve being fixedly connected to said flared connector, and arranged to enclose at least part of, and preferably essentially the whole, flared connector, apart from the catheter connector end.
- 10 2. The catheter of claim 1, wherein the gripping sleeve has an axial length significantly longer than the axial length of the flared connector.
3. The catheter of claim 1 or 2, wherein the gripping sleeve has an axial length which is at least 25% longer than the axial length of the flared connector, and preferably at least 50% longer.
- 15 4. The catheter of any one of the preceding claims, wherein the gripping sleeve has an axial length of at least 4 cm, and preferably at least 5 cm.
5. The catheter of any one of the preceding claims, wherein the catheter is a urinary catheter.
- 20 6. The catheter of any one of the preceding claims, wherein the gripping sleeve is connected to the flared connector end by means of a friction fit or mechanical interlocking.
7. The catheter of any one of the preceding claims, wherein the gripping sleeve is connected to the flared connector by means of at least one  
25 of welding and adhesion.
8. The catheter of any one of the preceding claims, wherein the flared connector is provided with an outwardly facing corrugation, and wherein the gripping sleeve is provided with a corresponding inwardly facing corrugation.

12

9. The catheter of any one of the preceding claims, wherein the gripping sleeve is provided with an outwardly facing corrugation.

10. The catheter of any one of the preceding claims, wherein the gripping sleeve is provided with outwardly protruding gripping means, such as  
5 wings.

11. The catheter of any one of the preceding claims, wherein the elongate shaft is provided with a hydrophilic surface coating.

12. The catheter of any one of the preceding claims, wherein the flared connector comprises an outwardly protruding flange in the vicinity of  
10 the catheter connector end, said flange providing an abutment for the gripping sleeve.

13. A method of producing a customized catheter, and preferably a urinary catheter, comprising the steps of:

15 providing a base catheter comprising an elongate shaft and a flared connector with a catheter connector end connected to one end of said elongate shaft; and

20 arranging a customizable gripping sleeve over said flared connector, to enclose at least a part of, and preferably essentially the whole, flared connector, apart from the catheter connector end, and fixedly connecting the gripping sleeve to said flared connector.

14. The method of claim 13, further comprising the step of selecting a suitable gripping sleeve among a plurality of available gripping sleeves.

25 15. The method of claim 13 or 14, wherein a plurality of different gripping sleeves are provided, and used on common base catheters to form a plurality of different catheters.

1/3

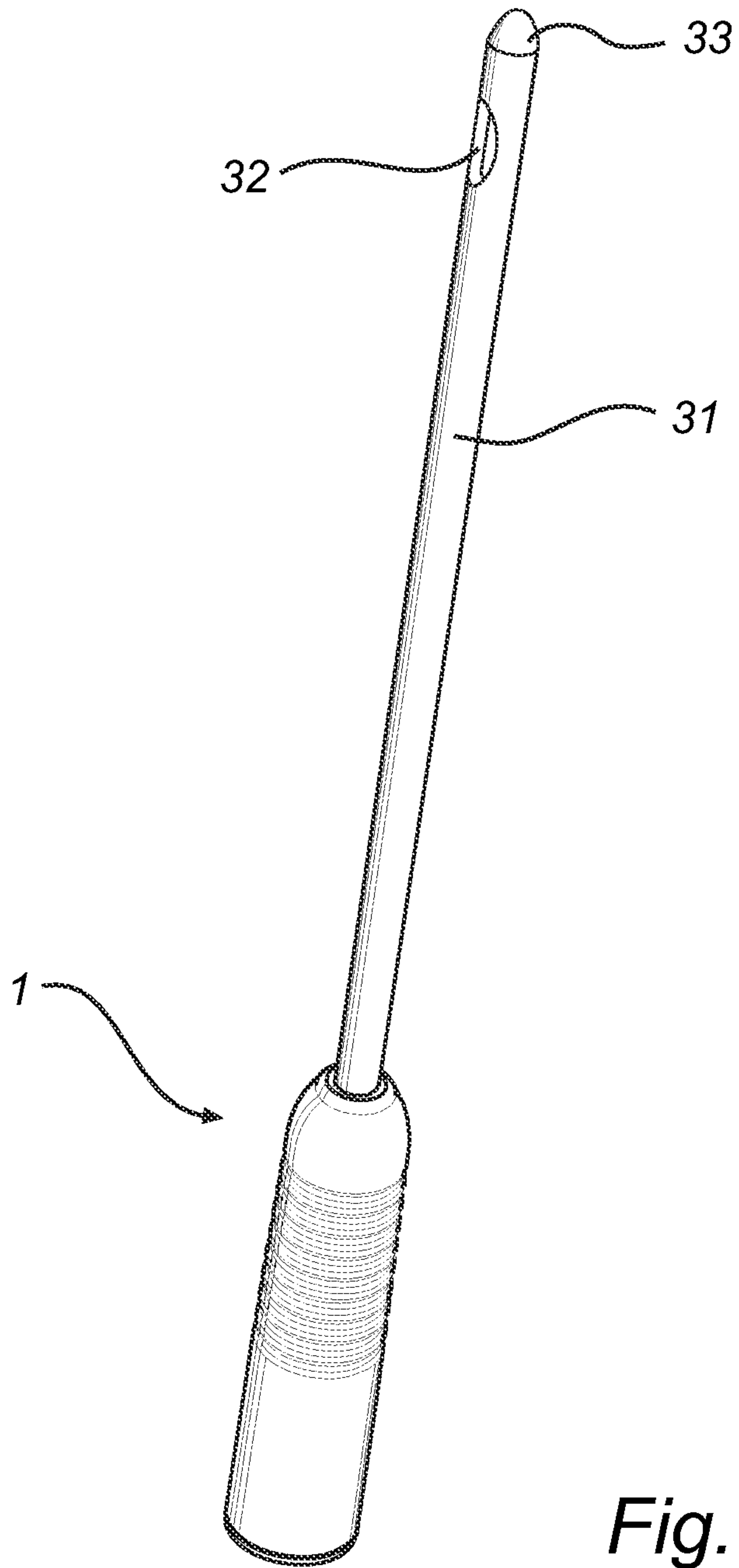

Fig. 1

2/3

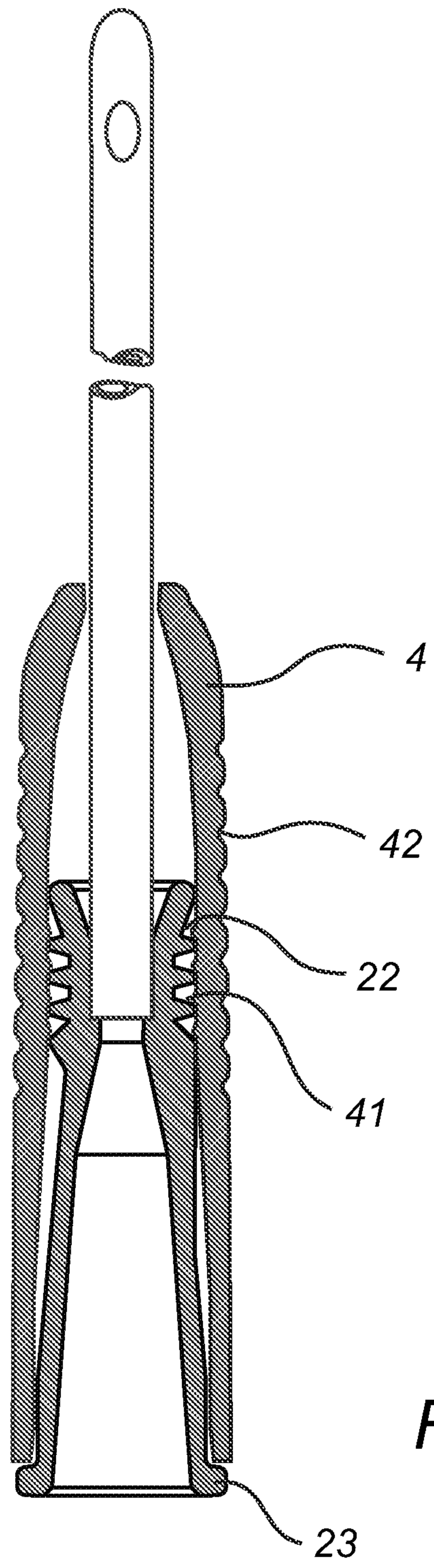

Fig. 2

3/3

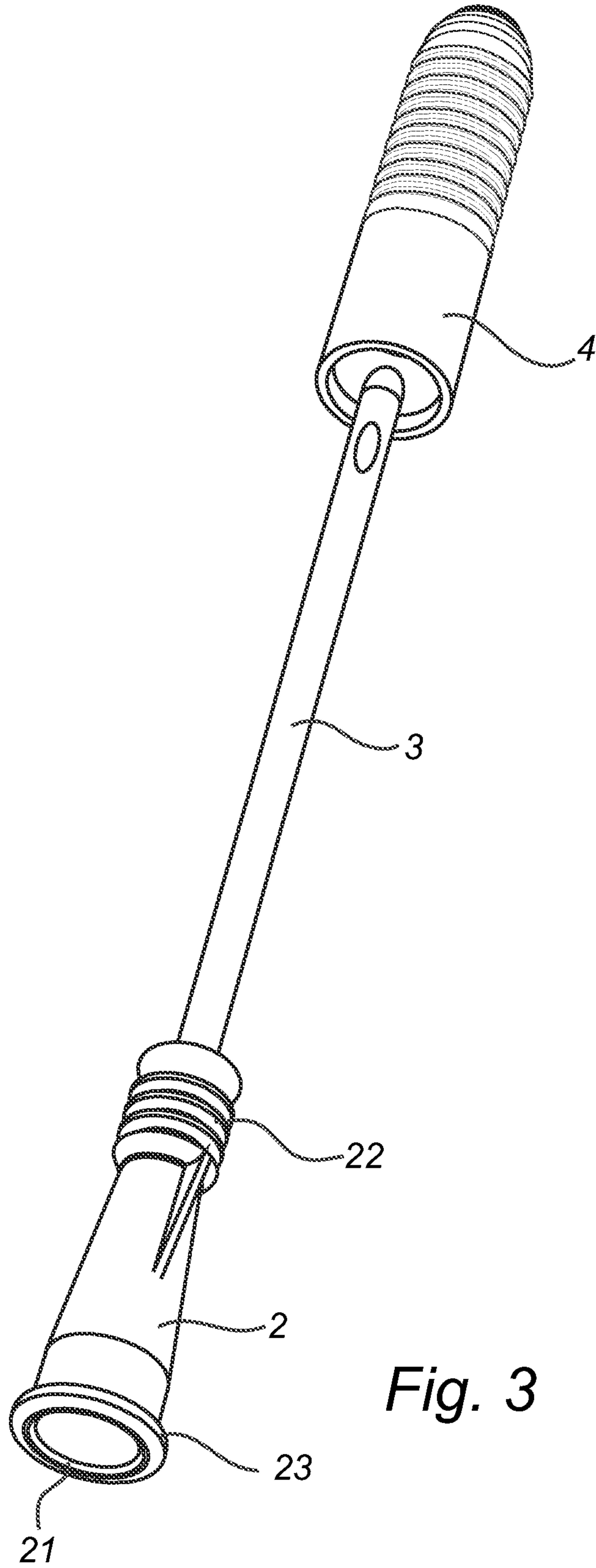
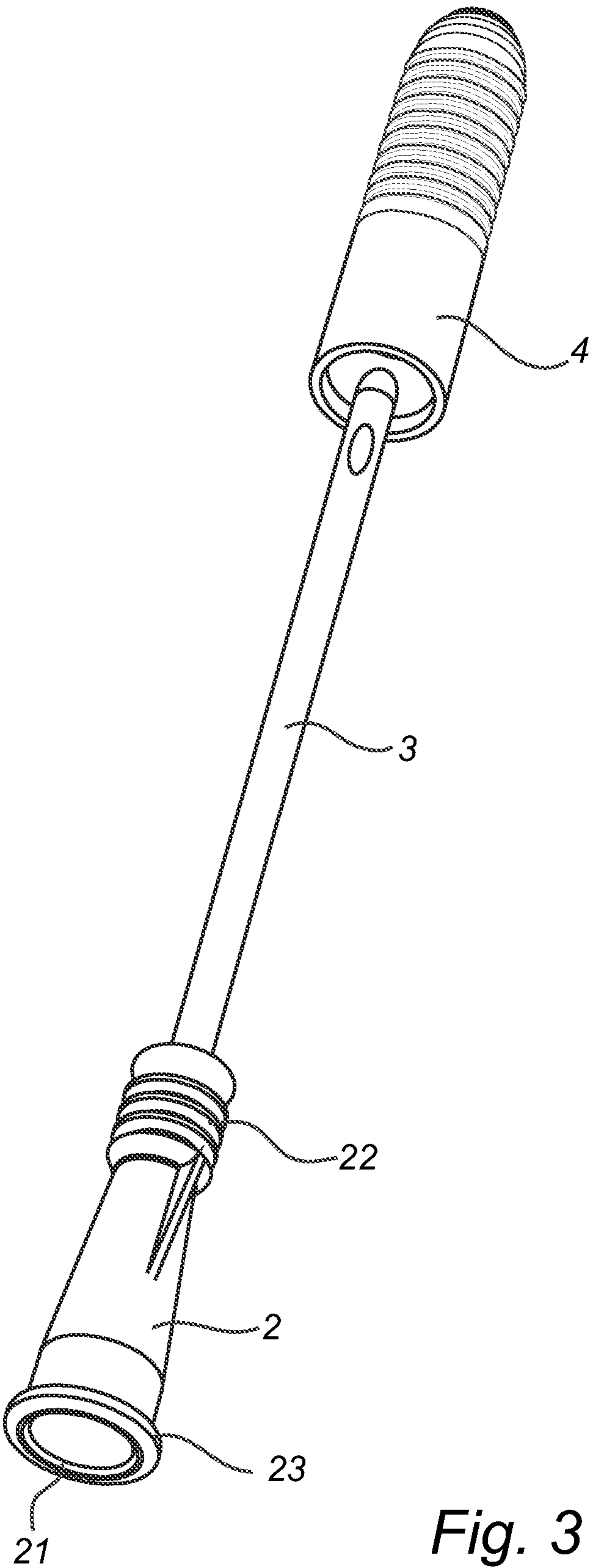

Fig. 3



*Fig. 3*