

J. SMITH.

WEATHER STRIP FOR DOORS, WINDOWS, &c.

No. 16,341.

Patented Jan. 6, 1857.

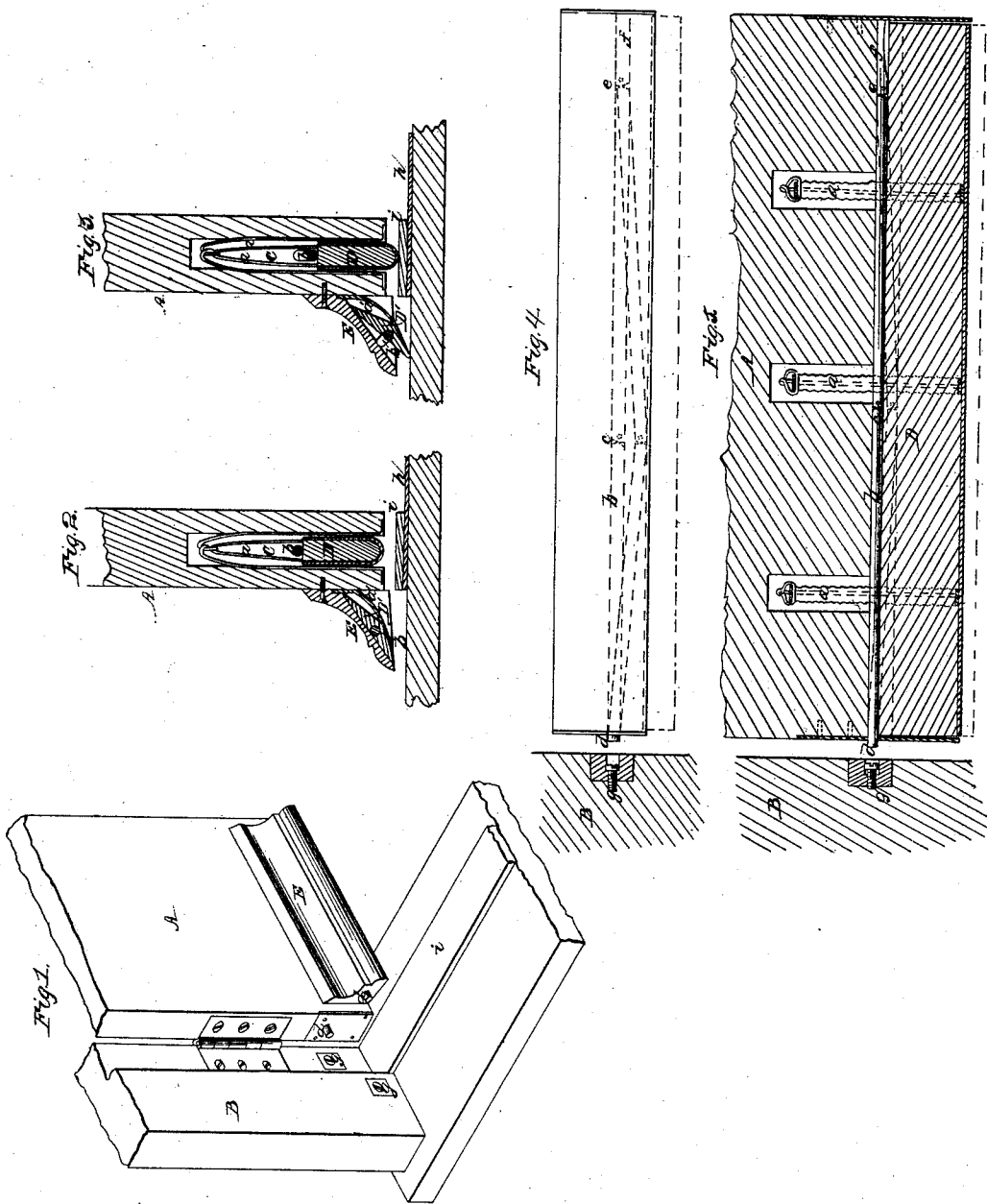

UNITED STATES PATENT OFFICE.

JAMES SMITH, OF CLEVELAND, OHIO.

WEATHER-STRIP FOR DOORS, WINDOWS, &c.

Specification of Letters Patent No. 16,341, dated January 6, 1857.

To all whom it may concern:

Be it known that I, JAMES SMITH, of Cleveland, in the county of Cuyahoga and State of Ohio, have invented certain new and useful Improvements in Weather-Strips for Doors, Windows, &c.; and I do hereby declare the following to be a full, clear, and exact description of the same, reference being had to the accompanying drawings, making a part thereof, in which—

Figure 1 represents in perspective a portion of a door and frame with the strip attached. Fig. 2 represents a vertical cross section through the door, with the strip raised up, and Fig. 3 represents a similar cross section with the strip lowered. Fig. 4 represents in elevation a portion of the door, and frame, the latter in section, to show the manner of adjusting and letting down the strip. Fig. 5 represents a vertical longitudinal section through a portion of the door and frame to show the manner of hanging and operating the strip.

Similar letters of reference where they occur in the several figures, denote like parts in all.

The nature of my invention consists in combining with the weather strip, a jointed rod, and suitable springs, so that a regulated end pressure, on the end of the jointed rod, shall lower the strip, when the door has closed, and the removal of the end pressure by opening the door, allow the springs to act in raising up said strip.

To enable others skilled in the art to make and use my invention, I will proceed to describe the same with reference to the drawings.

My invention is equally applicable to a shield on the weather side of a door, or to the door itself, or to both at the same time, and I have so represented it in the drawings.

A, represents a door, hinged to the frame B, in any of the usual well known ways. A groove C, may be cut longitudinally through the underpart of the door, in which the weather strip D, may be hung, by means of springs *a, a, a*, of either rubber, or metal, so that when not influenced by any pressure, the said strip shall not project below the bottom of the door, as seen in Fig. 2.

A rod *b*, lies immediately over the strip

D, said rod being jointed at or near its center with a rule-joint *c*, so that when pressure is applied to the loose end (*d*) of said rod, the joint *c* will allow it to go down in the center, and force down with it the strip D, elongating the springs *a, a, a*. A second joint *e*, may be made near one end of the rod *b*, so that its extreme end *f*, may be firmly held to the door, to give it its necessary rigidity.

In the frame of the door B, is a set screw *g*, against which the end *d*, of the rod, strikes as the door is closed, and the pressure on said end forces down the rod, and the strip with it, as shown by the red lines in Figs. 4 and 5. The set screw *g* may be brought nearer to or removed farther from the sweep of the rod *b*, so as to force the strip farther down, or not so far, as occasion may require; and when the door is opened the point *d* of the rod is instantly removed from the set screw, and the recoil of the springs *a, a, a*, raises up the strip D within its groove in the door. The strip D may be covered with rubber or any other suitable material that will not damage the carpet, as it is let down, and that will make a close fitting joint. With this kind of a weather strip, it is immaterial whether a carpet *h*, or a cleat *i*, be put under the door, or taken away, as such would not in the least affect the action of the weather strip; nor would the irregular settling of the floor prevent its entirely closing the space between the door and the floor, as by the setting of the screw, it can be brought down until it comes in contact with whatever is underneath it, and then the rod gives to any further pressure from below.

When the weather strip is applied to a shield E, on the outside of a door, the principle is in no way changed, but the form of the strip D', and the springs *a'*, will be slightly varied, but the same kind of jointed rod, and set screw are used in this, as in the former case. Indeed, the two weather strips may be advantageously used, on the same door, or window, as shown in Figs. 2, 3, the one D, to rest upon the carpet cleat *i*, and the other D', to rest upon the floor or sill outside of the cleat *i*, and thus the door closes itself effectually against rain, or wind.

Having thus fully described the nature of

my invention what I claim therein as new and desire to secure by Letters Patent is—

In combination with a weather strip, hung to its springs, a jointed rod, and set screw,
5 for operating it when said rod is made to press down the strip at one point only as herein set forth; and this I claim whether

the strip be arranged in the door, or in or under a shield on the door, or both, substantially as herein set forth and explained.

JAMES SMITH.

Witnesses:

THOS. H. UPPERMAN,
E. COHEN.