

(No Model.)

2 Sheets—Sheet 1.

M. M. CARMONA Y VALLE.
CAR COUPLING.

No. 401,005.

Patented Apr. 9, 1889.

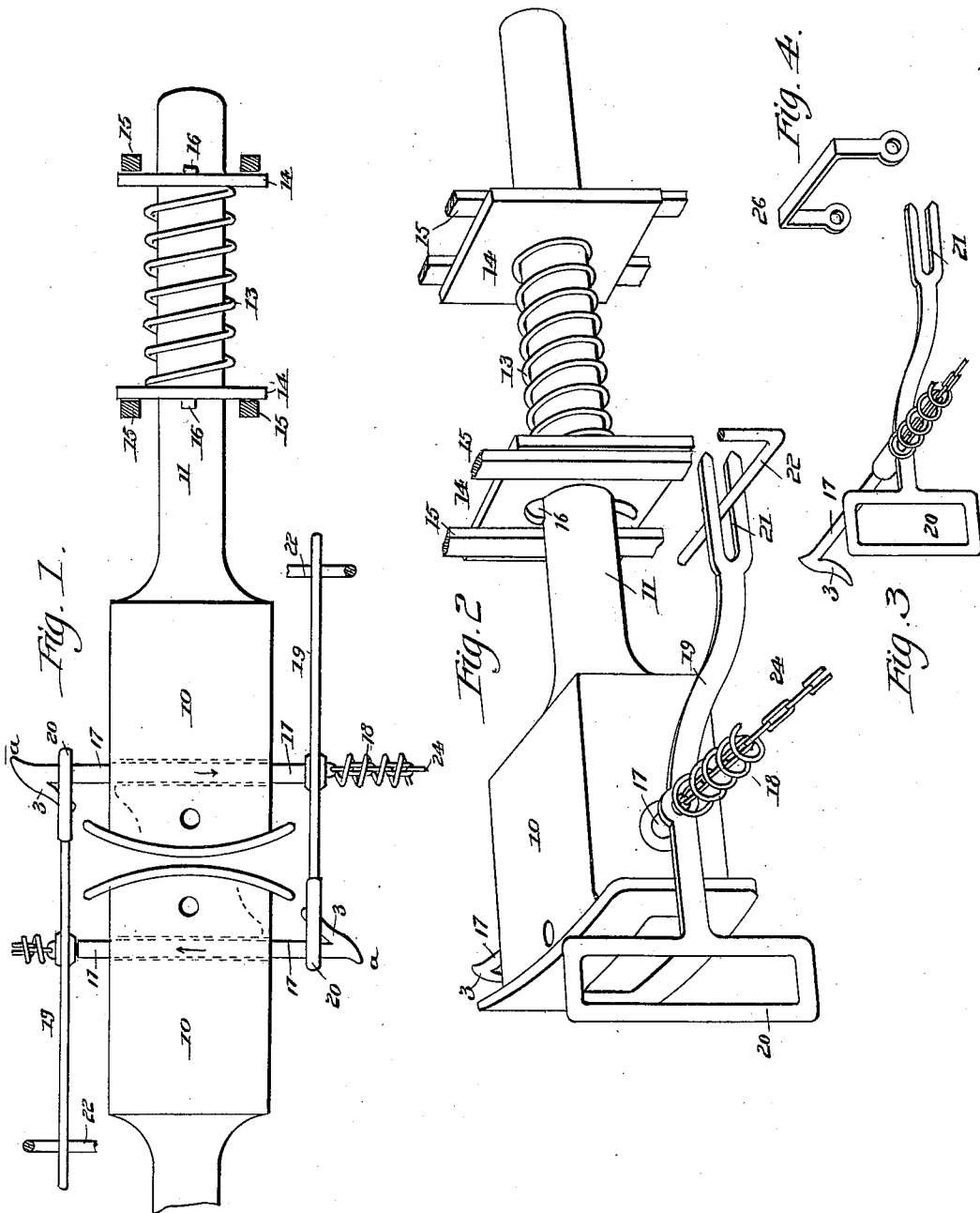

WITNESSES:
J. Clark.
C. Sedgwick

INVENTOR:
Manuel M. Carmona y Valle
BY *Munn & Co*
ATTORNEYS.

(No Model.)

2 Sheets—Sheet 2.

M. M. CARMONA Y VALLE. CAR COUPLING.

No. 401,005.

Patented Apr. 9, 1889.

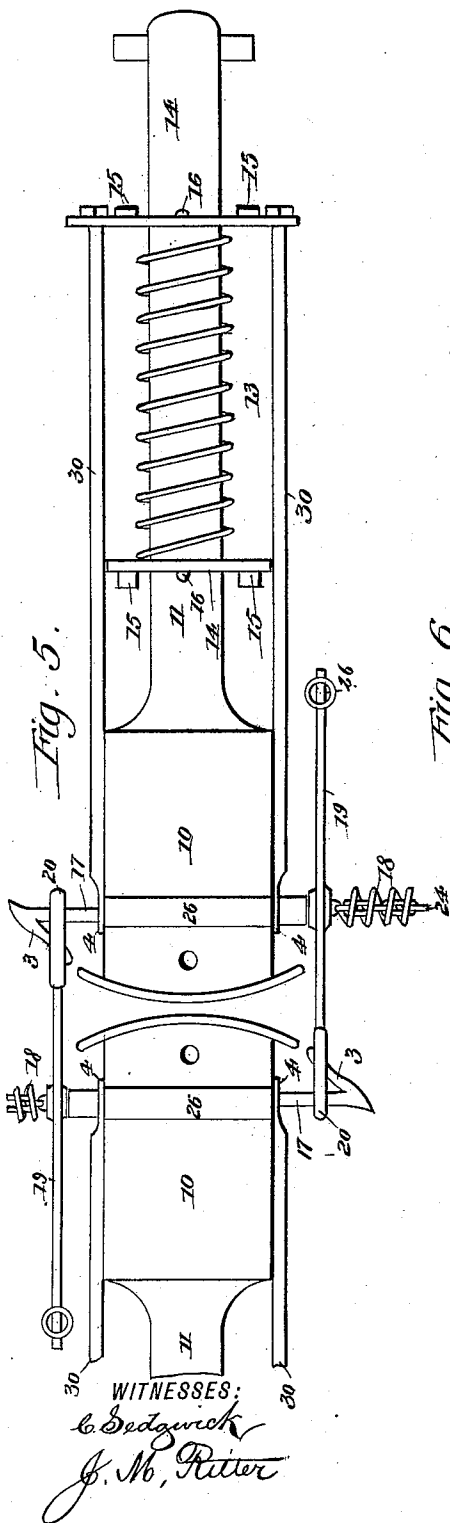

WITNESSES:

C. Sedgwick
J. M. Ritter

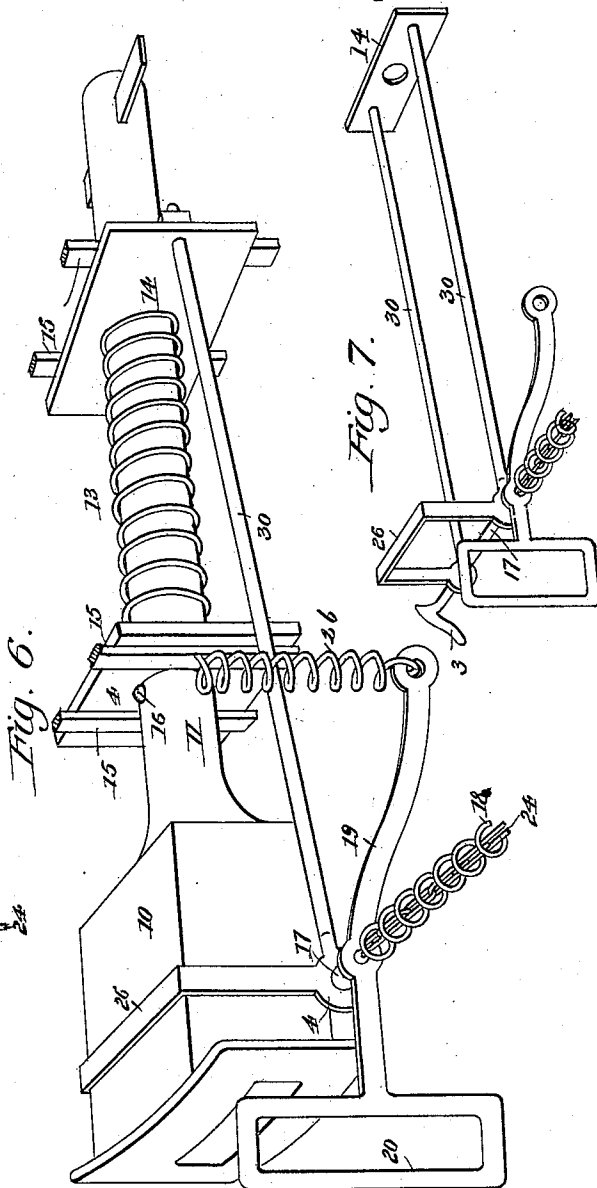

INVENTOR:

Manuel M. Carmona y Valle

BY

Munn & Co

ATTORNEYS.

UNITED STATES PATENT OFFICE.

MANUEL M. CARMONA Y VALLE, OF MEXICO, MEXICO.

CAR-COUPLING.

SPECIFICATION forming part of Letters Patent No. 401,005, dated April 9, 1889.

Application filed December 1, 1888. Serial No. 292,581. (No model.)

To all whom it may concern:

Be it known that I, MANUEL M. CARMONA Y VALLE, of the city of Mexico, Mexico, have invented a new and Improved Double Automatic Car-Coupler, of which the following is a full, clear, and exact description.

The object of this invention is to provide an automatic car-coupler by means of which cars may be doubly coupled, and which may be applied to any of the known forms of coupler, and that, too, without interfering with the action of the original couplers; and to the ends named the invention consists, essentially, of a coupling-link and a coupling-hook of novel construction, which link and hook are combined with a draw-frame when the coupler is applied to draw-heads not specially made to coact therewith, all as will be hereinafter more fully described, and specifically pointed out in the claims.

Reference is to be had to the accompanying drawings, forming a part of this specification, in which similar figures and letters of reference indicate corresponding parts in all the views.

Figure 1 is a plan view of my improved automatic coupler, the parts being represented as they appear when in the coupled position. Fig. 2 is a perspective view of my improved coupler. Fig. 3 is a perspective view, upon a smaller scale, of my coupler as it appears when removed from its draw-head. Fig. 4 is a perspective view of a saddle at times employed in connection with my coupler, the views above referred to illustrating a construction employed in connection with freight-cars. Fig. 5 is a plan view of my improved automatic double coupler constructed for use in connection with a passenger-car and arranged to coact with a draw-head of ordinary form. Fig. 6 is a perspective view of the construction shown in Fig. 1, and Fig. 7 is a perspective view of the coupling attachment, representing it as it appears when removed from the draw-head.

Referring now to the construction shown in Figs. 1, 2, and 3, 10 represents a draw-head and 11 a draw-bar of the form which I prefer to use in connection with my coupler, the draw-bar spring being shown at 13, the follower-plates at 14, and the draw-bar cage at

15, keys 16 being arranged in the ordinary manner. Through the draw-head 10 I form a bore or slot that is adapted to receive a coupling-pin, 17, normally held in the position shown in Fig. 1 by a spring, 18, said spring abutting against a fixed stop that is carried by the car-body.

To the free end of the pin 17 I rigidly connect an inwardly and forwardly extending arm, 3, and upon the other end of the pin I mount a lever, 19, at the forward end of which lever there is formed a coupling-link, 20. The rear end of the lever 19 is forked, as shown at 21, to embrace a rod, 22, that is arranged for connection with the car-body, or I could connect a spring, 23, (see Fig. 6,) to the rear end of the lever 19, said spring being connected to the car-body, and the tension of the spring being adjusted so that the link 20 would be normally held in about the position in which it is shown in the drawings.

As two cars provided with my improved coupler approach to couple, the forward lengths of the coupling-links 20 will bear against the inclined arms 3 of the coupling-pins 17, and the pins will be moved against the tension of their springs 18 in the direction of the arrows shown in Fig. 1, until the extending end *a* of each of the pins 17 clears the forward link length, after which the springs 18 will act to throw the pins 17 to the position shown in the drawings. To uncouple, the pins are drawn in the direction of the arrows by means of chains or rods 24, that are connected to the pins and extend outward through the springs, as shown.

In case it should be desired to couple cars in which the difference in height is greater than half the height of the link 20, the spring 23 (shown in Fig. 6) is employed instead of the rod 22, the links in this case being moved upward or downward by means of a lever that is placed against the draw-head as a fulcrum and brought to bear against the link-lever 19.

In Figs. 5, 6, and 7 I illustrate a construction by means of which my coupler may be applied to any of the well-known types of couplers without interfering with their action. To this end I provide a saddle, 26, which is passed over the draw-head and formed with

eyes 4, through which the coupling-pin 17 is passed, said pin extending beneath the draw-head. To the eyes 4 I connect rearwardly-extending auxiliary draw-bars 30, which pass
5 through apertures formed in the rear draw-bar plate. The saddle 26 might be arranged below the draw-head and the pin 17 above without departing from the spirit of my invention.

10 Having thus described my invention, I claim as new and desire to secure by Letters Patent—

1. The combination, with a draw-head, of a coupling-pin, a spring arranged in connection with the pin, and a coupling-link pivotally
15 connected to the pin, substantially as described.

2. The combination, with a draw-head, of a coupling-pin formed with a forwardly-extending and inwardly-inclined arm, a spring
20 arranged in connection with the pin, and a

coupling-link pivotally connected to the pin, substantially as described.

3. The combination, with a draw-head, of a coupling-pin provided with a forwardly-extending arm, auxiliary draw-bars through
25 which the pin passes, a saddle by which the draw-bars are connected, a lever pivotally mounted upon the coupling-pin, a link carried by the lever, and springs arranged in connection with the lever and coupling-pin,
30 substantially as described.

4. The combination, with a coupling-pin, of a link pivotally connected thereto, auxiliary draw-bars through which the pin passes, and a follower-plate through which the draw-bars
35 pass, substantially as described.

MANUEL M. CARMONA Y VALLE.

Witnesses:

PEDRO VIGIL,
FEODORO PEREZ.