

4 Sheets, Sheet 1.

R. M. Hoe.

Printing Press.

N^o 2029.

Patented May 20. 1842.

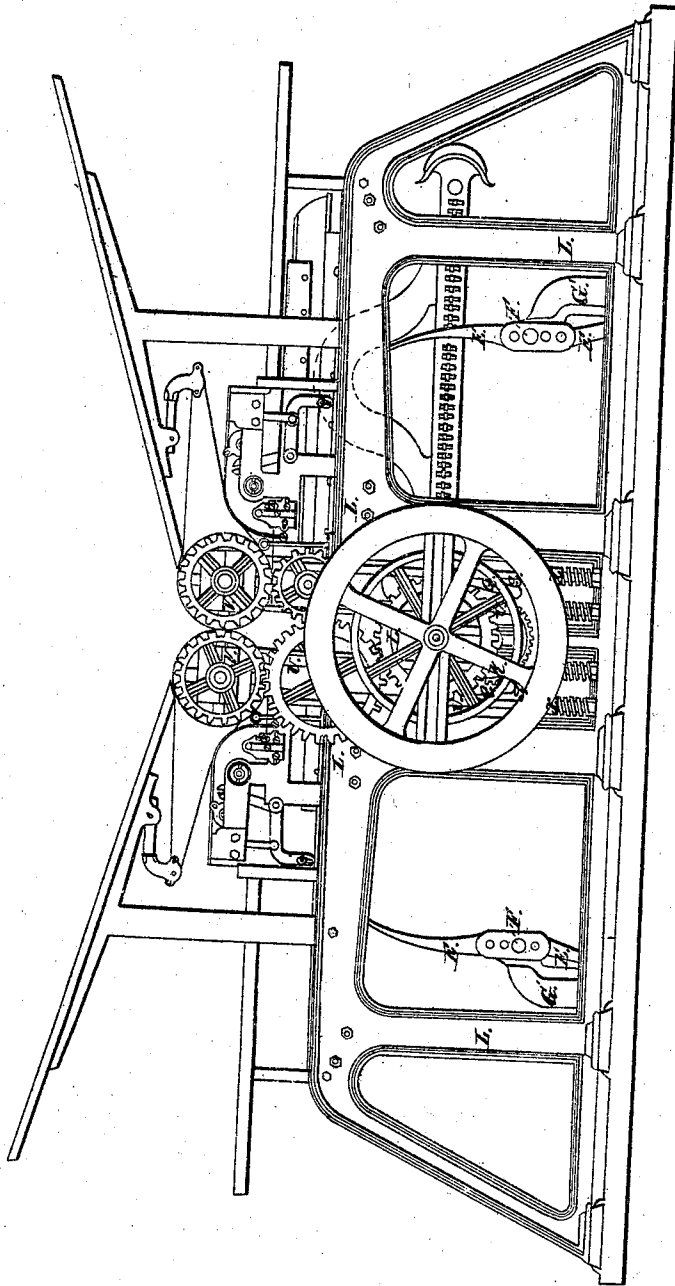

R. M. Hoe.

Printing Press.

N^o 2,029.

Patented May 20. 1842.

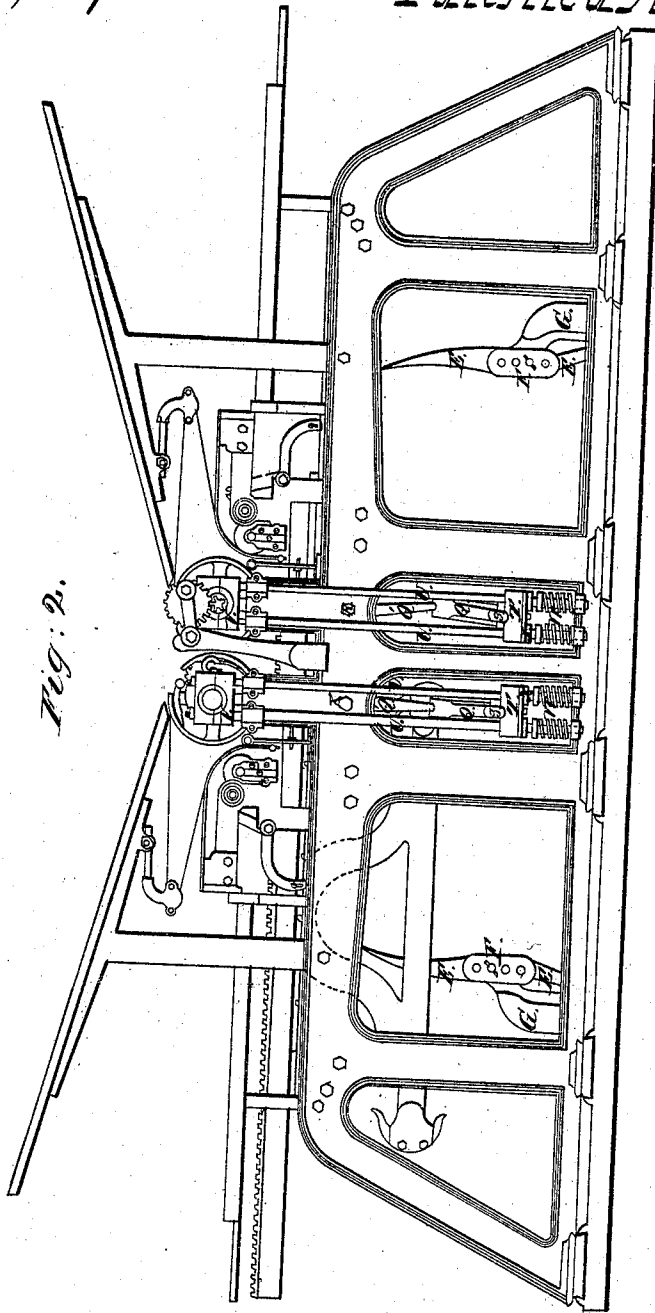

Fig: 2.

R. M. Hoe.

Printing Press.

N^o 2,029.

Fig: 3. Patented May 20 1842

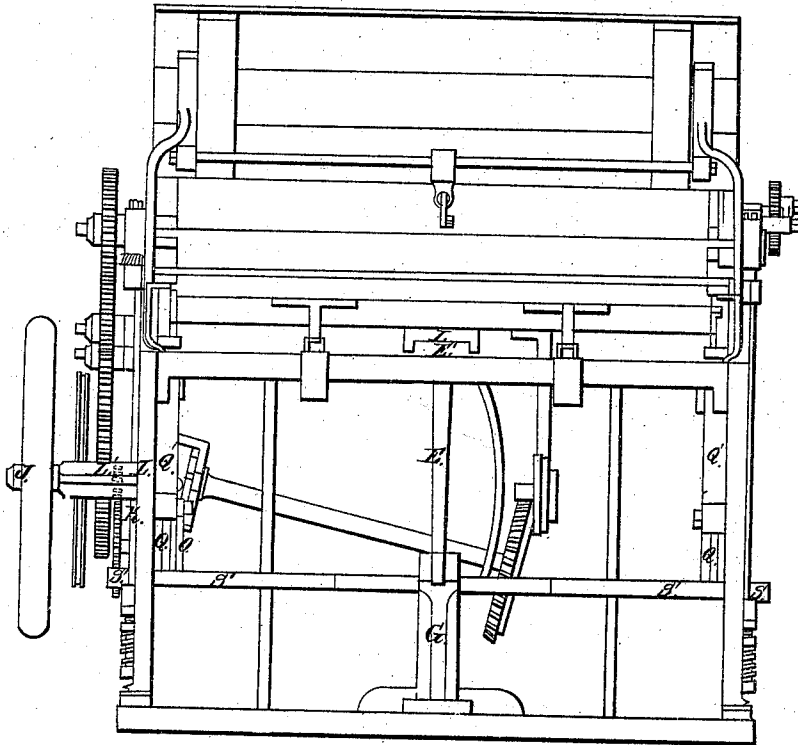
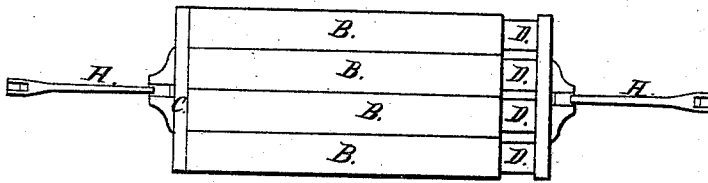

Fig: 5.



R. M. Hoe.

Printing Press.

N^o 2629.

Patented May 20. 1842.

Fig. 4.

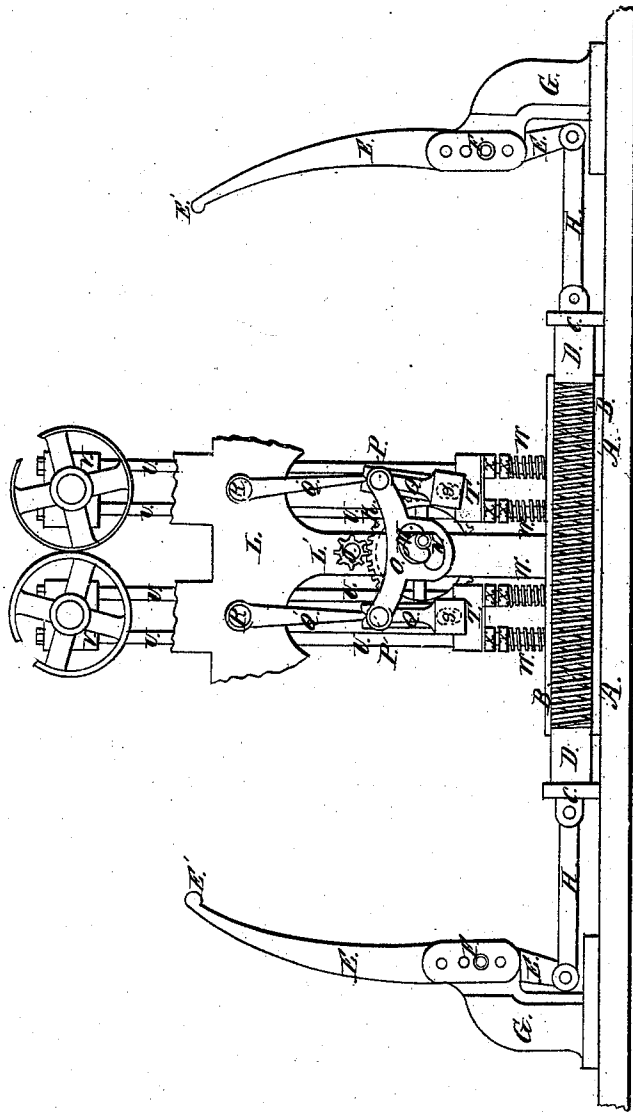

UNITED STATES PATENT OFFICE.

RICHD. M. HOE, OF NEW YORK, N. Y.

DOUBLE-CYLINDER PRINTING-PRESS.

Specification of Letters Patent No. 2,629, dated May 20, 1842.

To all whom it may concern:

Be it known that I, RICHARD M. HOE, civil engineer and machinist, of the city of New York, in the State of New York, have invented certain Improvements in Double-Cylinder Power Printing-Presses; and I do hereby declare that the following is a full and exact description thereof.

In its general construction this press combines what have been found to be the most valuable of the properties contained in the well known presses invented and patented in England by Applegath, by Cooper and Miller, and by Napier, upon the particular manner of arranging the respective improvements in these presses, which I have combined in my press. I do not now found any claim to an exclusive right; but I have made certain new and useful improvements in presses of this description, the first of which improvements consists in a novel and efficient arrangement of the levers and springs which are used to stop the momentum of the bed of the press at the end of its traversing motion in either direction; and the second is an improvement in the manner of raising and lowering the pressing cylinders, so as to cause them to rise and fall with the most perfect steadiness, without the possibility of their being subjected to those jerks, to which they have been liable under a rapid motion of the press as heretofore constructed.

In the accompanying drawing Figures 1 and 2 represent two side elevations of my press; Fig. 3 an end view thereof; and Fig. 4 a representation in outline of such parts as contain my new improvements; those portions of the press which are not necessary to an explanation of these improvements being omitted in this figure.

In the respective Figs. 1, 2 and 3 I shall give references to those parts only which I believe to be substantially new, the others being already known to those who are conversant with modern printing machinery.

For preventing the injurious effects upon the machinery which under the ordinary arrangement of the press are produced by the stopping of the momentum of the bed, when its motion is to be reversed, the following is the plan adopted by me. On the lower part or basis of the frame work of the press I inclose, within suitable tubes or cases (or arrange on the outside or around iron or other rods), three, four, or any other desired num-

ber of spiral springs, which are laid horizontally in the direction of the length of the press each spring being contained within a separate case or tube (or on a separate rod) on, or within, which it may move freely. In Fig. 4, A A represents one of these springs, and B B the tube, or case, within which it is contained; the latter being shown in section for the purpose of exhibiting the springs within it. Into each end of the tubes, or cases, containing the springs, there enters a follower, or piston D, D, the ends of which bear against the springs A A; each set of these pistons is connected to a piece of metal C C, by which they are made to operate together, either as a bearing to sustain the reaction of the springs, or as followers pressing them inward.

E E, in each of the figures, is a lever working on a fulcrum pin F, in standards G G, there being several holes through the lever and standard to vary the fulcrum of the lever. The levers E are connected to the pieces C by a jointed rod H H. As the bed traverses back and forth, a stop I, on the underside of the bed, is brought into contact, alternately, with the upper ends E' E', of the levers, and the bed is, by the recoil of the springs, effectively checked, without any injurious jarring of the machinery.

Fig. 5 is a top view of the case, or tubes, containing the springs, these being represented as four in number, with their pistons, the pieces C, C by which the pistons are combined together, and the connecting rods H H. By the foregoing arrangement of the respective parts, the bed may be arrested at any required period of its progress and that with but little play in the springs which consequently retain their elasticity unimpaired for a great length of time. Although I have named, and prepared, spiral springs, others may be used which may be similarly combined, and operate so as to produce a like effect.

My improvement in the manner of raising and lowering the pressing cylinders consists in placing a pinion on the main driving shaft which pinion gears into a wheel having a cam on its axis that rocks two horizontal rock shafts, which raise and lower the pressing cylinders alternately, with a perfectly smooth and equable motion. To effect this I place a pinion upon the main driving shaft J, which pinion gears into a toothed wheel K Figs. 1, 3 and 4. The situ-

5 ation of this pinion is shown by the dotted lines at L' Figs. 3 and 4, the part marked L being a portion of the interior surface of the side frame L L, upon the exterior surface of which the wheel K, and the pinion L', are situated. M, Fig. 4 is a cam on the axis of the wheel K, which cam operates within an opening N, in the rocking piece O, the arms of which rocking piece are
 10 jointed at P P, to the toggles or progressive levers Q Q Q' Q'; the latter turn on stationary pins R R, affixed to the frame L; and the lower ends of the former are firmly attached to vibrating or rocking shafts S', S', which cross from side to side of the machine, their ends S, S, bearing on the connecting pieces T, T, which are alternately forced down by them, as one or other of the shafts is depressed by the toggles.
 15 U, U, are pairs of rods made fast to the connecting pieces T T, and to the brasses V, V, which constitute the bearings of the gudgeons of the pressing cylinders; the rods U, U, slide up and down freely in suitable
 20 guides, pass through spiral springs W, W, and have on them adjusting nuts X X, by which the tension of the springs, and the position of the rods, may be readily adjusted. The form given to the cam M, and to the cavity N, within which it revolves, as shown in the drawing, is such as will alternately raise and lower the two arms of the rocking piece O, and will consequently,
 25 through the intermedium of the parts above described, compel the pressing cylinders to rise and fall with an equable motion, without its being possible that those jerks should
 30
 35

occur to which they are liable under the construction of the apparatus by which their motion has heretofore been effected. 40

Having thus fully described the nature of my improvements in the double cylinder power printing press what I claim therein as new and desire to secure by Letters Patent is— 45

1. The particular arrangement of the spiral or other springs, levers, pistons, and their appendages, for arresting the momentum of the bed the springs being placed on, or near to, the foundation or base of the machine and being connected with the levers which receive the blow of the bed at either end, as its motion is about to be reversed; the whole arrangement and operation being substantially the same with that herein described. 50 55

2. I claim the manner herein set forth of combining and arranging the apparatus for raising and lowering the pressing cylinders; that is to say, I claim the manner of governing and regulating this motion by means of a pinion placed on the main driving shaft and operating upon a wheel carrying a cam which actuates a rocking piece connected with toggle joints or progressive levers that raise and lower the respective cylinders alternately through the intermedium of an apparatus arranged substantially in the manner herein fully made known. 60 65

RICHD. M. HOE. [L. s.]

Witnesses:

THOS. S. HOLLINGSWORTH,
 JOHN WHEATMAN.