

G. L. ANDERS.

Improvement in Printing-Telegraph Apparatus.

No. 129,641.

Patented July 23, 1872.

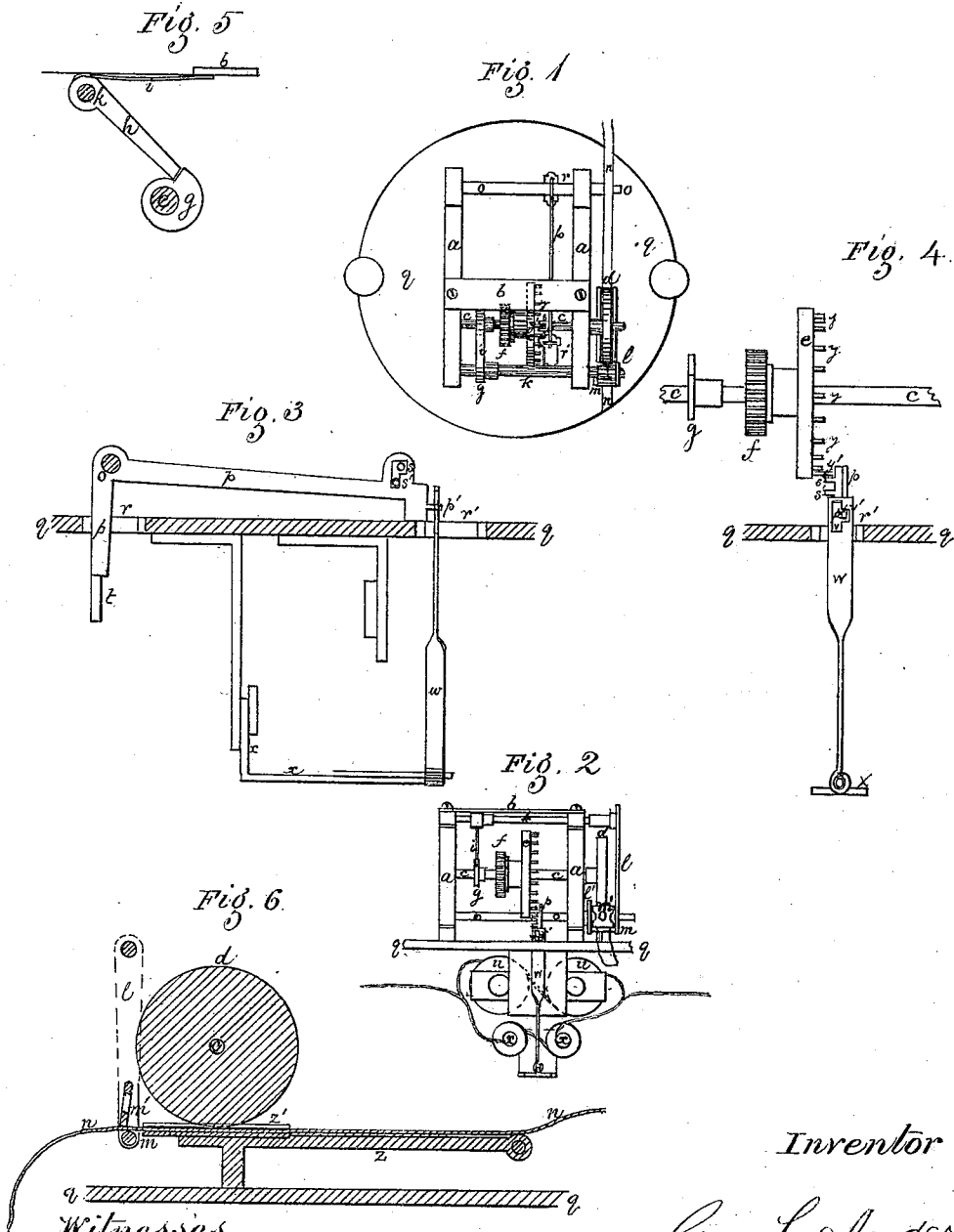

Inventor

Geo L. Anders

Witnesses
Carroll D. Wright
Sam^r. M. Barton.

UNITED STATES PATENT OFFICE.

GEORGE L. ANDERS, OF BOSTON, ASSIGNOR TO E. B. WELCH, OF CAMBRIDGE, MASSACHUSETTS.

IMPROVEMENT IN PRINTING-TELEGRAPH APPARATUS.

Specification forming part of Letters Patent No. 129,641, dated July 23, 1872.

SPECIFICATION.

I, GEORGE L. ANDERS, of Boston, in the county of Suffolk and State of Massachusetts, have invented certain Improvements in Electro-Magnetic Printing-Telegraph Instruments, of which the following is a specification:

Figure 1 in the drawing is a top view, and Fig. 2 is a front view, of my improved electro-magnetic printing-telegraph instrument. Figs. 3, 4, 5, and 6 are parts in detail embodying the general principles of my invention.

The present invention relates to certain new and useful improvements in electro-magnetic printing-telegraph instruments, and has for its main object reliability and rapidity of action. My improvements consist in a series of devices, to be fully explained in due course, so arranged and operated as to control the vibrating distance of the armature of an electro-magnet by the polarity of the current transmitted through the electro-magnet in such a manner that in its shorter vibrating distance it shall effect the release of an escape-wheel, and in its greater action shall secure the impression of the desired letter on a strip of paper; also, of so arranging and operating an escape-wheel, in connection with other devices of the instrument, as to allow of the adjustment of the type-wheels of two or more instruments at the proper point to obtain the impression of a letter on the strip of paper passing below them; and, lastly, of a device, in connection with other devices of the instrument, arranged and operated so as to regulate the feeding of the paper after each impression.

a a in the drawing represent a frame of a telegraphic instrument, connected at the top by a bar, *b*. Supported by the frame *a a* is an arbor, *c c*, to which are connected a type-wheel, *d*, escapement-wheel *e*, gear *f*, connecting with a train of wheels and weights, and cam-wheel *g*, which connects with a spring, *i*, and operates a lever-arm, *h*, turning an arbor, *k*, which is supported by the frame *a a* and actuates an arm, *l*, connected by a feed-roller, *m*, with a shorter arm, *l'*, together forming a standard for the support of a swing-clutch, *m'*, between which and the roller *m* a strip of paper, *n*, is fed along and controlled in its passage, as will be hereinafter described. At-

tached to an arbor, *o o*, at the back of the lower portion of the frame *a a*, is a bell-crank-lever arm, *p*, one end of which extends down through a slot, *r*, formed in the top of the instrument-case *q*, and forms an armature, *t*, that is actuated by the electro-magnet *u u*. The lever-arm *p* is formed near the front end with pallets *s s'* and a dog, *p'*, the latter connecting with a double slot, *v v'*, formed in the top of an armature, *w*, that extends through a slot, *r'*, formed in the top of the instrument-case *q*, and is operated so as to swing either to the right or left by the action of the polarized magnet *x x*. The pallets *s s'* are so arranged as to engage with or be disengaged from pins or teeth *y y y*, &c., or their mechanical equivalents, arranged at proper intervals on the escapement-wheel *e*, which is also provided with one long pin, *y'*, or its mechanical equivalent. Attached to and operated by the arbor *o o* is a lever-arm, *z*, operating a press, *z'*, through which passes the paper *n* in such a manner as to bring the paper *n* at the desired intervals against the type-wheel *d* and impress it with the letter required, the action of the lever-arm *z* and press *z'* being regulated by the operation of the pallets *s s'* in connection with the pins *y y y*, &c., and the pin *y'* of the escapement-wheel *e*, together with the cam-wheel *g*, and the lever-arm *h*, and spring *i*, the latter acting against the bar *b* of the frame *a a*.

The operation of my improvements is as follows: By the action of the armature *t*, lever-arm *p*, and pallets *s s'*, and the dog *p'* in the short slot *v*, all the pins *y y y*, &c., and *y'* in the escape-wheel *e*, are allowed to pass one by one the pallets *s s'* until a desired letter is reached; then, through the action of a reverse current on the polarized magnet *x x* and armature *w*, the long slot *v* is presented to the dog *p'*, and the armature *t* is attracted nearer the poles of the magnet *u u*, and elevates the press *z'* against the desired letter on the type-wheel *d*, and when drawn back a greater distance from the poles of the magnet *u u* it allows the pallets *s s'* to permit all the short pins *y y y*, &c., to pass by, and retains the long pin *y'*, from which point the selection of the next letter begins. As one revolution of the type-wheel *d* and escapement-arbor *c c* is required

for each impression of a letter, it will be seen that the cam *g*, operating the arm *h*, lever-arm *l*, and clutch *m'*, will draw along the paper *n*, between the type-wheel *d* and press *z'*, a sufficient distance for each impression, thus regulating its feed, and by this arrangement it will also be seen that the paper *n* is fed along by the motive power connected with the instrument.

Having thus fully described my improvements, what I claim as my invention, and desire to have secured to me by Letters Patent, is—

1. A printing-telegraph instrument, having an electro-magnet, *u u*, the vibrating distance of whose armature *t* is controlled by the polarity of a current transmitted through the electro-magnet *x x* in such a manner that in the shorter vibrating distance of the armature *t* it shall effect the release of the escapement-wheel *e*, and in its greater action shall secure an impression of a letter on a strip of paper, *n*, substantially as specified.

2. The escapement-wheel *e*, provided with short pins *y y y*, &c., and a long pin, *y'*, so operated that the escapement-wheel *e* is released by the action of the electric currents to the desired letter, and is then at once thrown forward to the standard point, regulated by the long pin *y'* on the escapement-wheel *e*, substantially as specified.

3. The pallets *s s'* on the bell-crank-lever arm *p*, arranged as shown, to allow the passage of the pins *y y y*, &c., in combination with the armatures *t* and *w*, substantially as specified.

4. The armature *w*, formed with a double slot, *v v'*, in combination with the polarized magnet *x x*, bell-crank-lever arm *p*, and escapement-wheel *e*, substantially as specified.

5. The bell-crank-lever arm *p*, arranged with pallets *s s'* and dog *p'*, connected with and operated by the armatures *t* and *w*, substantially as specified.

6. The cam-wheel *g* on type-wheel arbor *c c*, in combination with arm *h*, spring *i*, and arbor *k*, so operating the arms *l l'* as to feed along the paper *n*, either with or independently of the transmission of the electric currents operating the press (*z'*) mechanism, substantially as specified.

7. The combination of an electro-magnet and polarized magnet, the polarized magnet controlling the vibrating distance of the armature of the electro-magnet.

In testimony whereof I have signed my name to this specification in the presence of two subscribing witnesses.

GEO. L. ANDERS.

Witnesses:

CARROLL D. WRIGHT,
SAML. M. BARTON.