



12 **NEW EUROPEAN PATENT SPECIFICATION**

45 Date of publication of the new patent specification : **11.05.94 Bulletin 94/19**

51 Int. Cl.<sup>5</sup> : **G01R 31/36, H02J 7/10, B26B 19/28**

21 Application number : **87200844.6**

22 Date of filing : **11.05.87**

54 **Device for indicating the charge status of a battery.**

30 Priority : **15.05.86 NL 8601243**

43 Date of publication of application : **09.12.87 Bulletin 87/50**

45 Publication of the grant of the patent : **08.08.90 Bulletin 90/32**

45 Mention of the opposition decision : **11.05.94 Bulletin 94/19**

84 Designated Contracting States : **AT DE ES FR GB IT NL SE**

56 References cited :  
EP-A- 0 110 466  
EP-A- 0 164 890  
CH-A- 648 936  
DE-A- 2 313 566  
DE-A- 2 851 599  
DE-A- 3 100 503  
DE-C- 3 031 852  
DE-C- 3 031 853  
US-A- 4 392 101  
US-A- 4 525 055  
US-A- 4 553 081

73 Proprietor : **N.V. Philips' Gloeilampenfabrieken Groenewoudseweg 1 NL-5621 BA Eindhoven (NL)**

72 Inventor : **Ijntema, Johannes c/o INT. OCTROOIBUREAU B.V. Prof. Holstlaan 6 NL-5656 AA Eindhoven (NL)**  
Inventor : **Van den Akker, Jouw c/o INT. OCTROOIBUREAU B.V. Prof. Holstlaan 6 NL-5656 AA Eindhoven (NL)**  
Inventor : **Verrij, Jacob Frederik c/o INT. OCTROOIBUREAU B.V. Prof. Holstlaan 6 NL-5656 AA Eindhoven (NL)**  
Inventor : **Folmer, Lambert Johan Hendrik c/o INT. OCTROOIBUREAU B.V. Prof. Holstlaan 6 NL-5656 AA Eindhoven (NL)**  
Inventor : **Hishiki, Teruo c/o INT. OCTROOIBUREAU B.V. Prof. Holstlaan 6 NL-5656 AA Eindhoven (NL)**

74 Representative : **Peters, Rudolf Johannes et al INTERNATIONAAL OCTROOIBUREAU B.V., Prof. Holstlaan 6 NL-5656 AA Eindhoven (NL)**

**EP 0 248 461 B2**

## Description

The invention relates to a device for indicating the charge status of a battery during charging and/or discharging comprising:

- 5 a power-supply circuit for charging the battery and/or energizing a load ( $R_L$ );
- clock means for generating clock pulses during charging and/or discharging of the battery;
- computing means for computing the charge status on the basis of the generated clock pulses; and
- indicator means for indicating the computed charge status.

10 Such a device is suitable for use in rechargeable apparatuses, in particular in rechargeable electronic shavers.

Such a device is known from CH-A-648 936. The known apparatus contains a current measuring device, placed in series with the battery and the load. At regular intervals the current flowing through the measuring device is measured and stored in a storage and calculation device. The length of the intervals is measured using a clock, which generates regular clock pulses. By multiplication of the momentaneous strength of the current and the length of the interval between two measurements an approximation is obtained of the amount of charge that is extracted from the battery. This amount of charge is subtracted from the nominal charge capacity of the battery and the outcome of the subtraction is presented as the remaining charge left in the battery.

20 In some circumstances, for example due to aging or due to a wrong use of the battery, the nominal capacity may be overestimated with respect to the actual capacity and the battery runs out before the device has calculated and indicated zero remaining charge. If this situation is detected, the reduced actual capacity is derived from the fact that the battery is empty and subsequently stored in the storage and calculation device to replace the nominal capacity, so that during a new discharge cycle the device correctly indicates the charge status using the revised capacity and an unexpected running out of the battery is avoided.

25 A disadvantage of the known device is that for determining the charge status it is necessary to connect current measuring means in series with the load between the battery terminals. As a result of this the known device is not suitable for use in, for example, a rechargeable electronic shaver, in which the load is constituted by a motor. When this motor is energized by the battery, the voltage drop across the current measuring means should be very small, because otherwise the motor characteristic will be affected adversely. To avoid the adverse effect the current measuring means should have such a low resistance value that obtaining a sensible output from the current measuring device presents major problems.

In addition, the nominal battery capacity is only adapted to the actual battery capacity when the battery is exhausted. So at a moment the user is confronted with an apparatus that is unexpectedly not functioning.

35 Further it is known from the CH-A-648.936 to dispense with the current measuring means in the situation wherein the load is known. In other words if the current consumption by the load is predetermined then a time measurement would suffice to determine the discharge of the battery. If however the current consumption of the load is not known before or only known to some inaccurate value then current measurement is apparently unavoidable.

40 Also from DE-A-23 13 566 a device is known for indicating the charge status of a battery. During charging and discharging of the battery this device measures the charging and discharging currents by means of a resistor connected in series with the battery. The voltage across this resistor is amplified and then integrated, the gain and the integration constant during discharging being different from those during charging of the battery. The integrated voltage is compared with a reference voltage and each time that this reference voltage is reached a pulse is generated. These pulses are supplied to a counter whose count is displayed by means of an indicator which indicates the charge status of the battery. When the battery is discharged a warning signal is generated as soon as a specific count is reached and after a certain time the load is disconnected from the battery to preclude complete discharging of the battery. During charging of the battery the charging circuit is disconnected when a maximum count is reached to prevent the battery from becoming overcharged.

45 As this device also contains a resistance in series with the load it suffers from the same kind of disadvantages as mentioned already. Moreover, the known device does not allow for deviations from the nominal capacity of the battery.

50 From DE-A-28 51 599 a device is known which device comprises a clock generating clock-pulses during the discharging of a battery. The known device is intended to test the charge capacity of a battery. During the discharging of the battery the clock-means generates clock-pulses which are added to measure the passing of time. During the discharging the battery voltage is checked, and if it falls below a threshold value before a predetermined period of time has passed the amount in which the battery capacity has deteriorated can be accessed by the number of clock-pulses counted. If, after passing of the predetermined period of time, the threshold level has not been reached, the condition of the battery is concluded to be satisfactory. This known

device does not compute and indicate the charge status of the battery during discharging.

It is an object of the invention to provide a device which enables an accurate indication of the charge status of a battery to be obtained without directly measuring the charging and discharging currents. According to the invention a device of the type defined in the opening paragraph is characterized in that:

the computing means comprise:

first adjusting means for adjusting a discharging time of the battery to a first value during discharging of the battery by the load and/or second adjusting means for adjusting a charging time of the battery to a second value during charging of the battery by the power-supply circuit under no-load condition, and

time-measuring means for determining, on the basis of the generated clock pulses alone, the ratio between the elapsed discharging time and said first value representing the adjusted discharging time and/or for determining the ratio between the elapsed charging time and said second value representing the adjusted charging time, which ratios represent the computed charge status,

and in that the device further comprises:

detection means for detecting at least one actual charge status of the battery during virtually every discharging and/or virtually every charging cycle of the battery,

correction means for correcting the computed charge status and for correcting the first value of the first adjusting means and/or the second value of the second adjusting means when a difference occurs between said at least one actual charge status detected by the detection means and the computed charge status at the instant of detection, and

control means for controlling the first and/or second adjusting means and time-measuring means.

The operation of the device in accordance with the invention does not require the measurement of charging and discharging currents but is based on an adjusted and initially nominal discharging time and/or charging time for a given capacity of the battery. The charge status is determined by measuring the elapsed discharging time and/or charging time and expressing them as a fraction of the nominal discharging time and/or charging time. In order to preclude errors in the computed charge status due to deviations from the nominal values of, for example, the charging and/or discharging currents the computed charge status is compared with a measured actual charge status during the discharging and/or charging of the battery. In the case of a difference the computed charge status is corrected and the adjusted discharging or charging time is also corrected, so that during the next discharging or charging cycle of the battery the computed charge status will be better in conformity with the actual charge status.

The device in accordance with the invention is therefore suitable for indicating the charge status either during discharging or discharging of the battery and also for indicating the charge status both during discharging and charging of the battery.

In order to minimize possible deviations between the computed and the actual charge status of the battery in the case of comparatively slow charging processes the computed charge status is compared with an actual charge status and, if necessary, corrected not only during discharging but preferably also at a specific instant during charging of the battery.

If the battery is charged very rapidly, for example in a few minutes, it may be less interesting to the user to have information on the charge status of the battery during charging. In such a case it is adequate to compare the computed charge status with an actual charge status of the battery and, if necessary, correct it only during discharging.

One embodiment may be characterized in that the detection means for detecting said at least one actual charge status during discharging of the battery comprise a first detection device for detecting a decrease of the battery voltage below a reference voltage.

Another embodiment may be characterized in that the detection means for detecting said at least one actual charge status during charging of the battery comprise a second detection device for detecting the substantially fully-charged condition of the battery. This embodiment may be characterized further in that the second detection device comprises a device for detecting a battery-voltage decrease which occurs when the battery is in the substantially fully charged condition. A further embodiment may be characterized in that the second detection device comprises a device for detecting whether the battery voltage is equal to a reference voltage.

Apart from during discharging of the battery by the load and during charging of the battery by the power-supply circuit under no-load conditions the charge status may also be calculated and adapted in a number of other situations, in order to ensure that the computed charge status agrees as far as possible with the actual charge status. For example, the charge status may also be computed in the situation in which the load is energized by the power-supply circuit, when also a specific charging current may be supplied to the battery. To this end an embodiment may be characterized in that the computing means further comprise third adjusting means for adjusting a charging time of the battery to a third value during charging of the battery by the power-supply

circuit in its loaded condition.

When the battery is almost fully charged the usual power supply circuits change over to a trickle-charging mode. In this situation the charge status can be calculated if the device in another embodiment is characterized in that the computing means further comprise fourth adjusting means for adjusting a charging time of the battery to a fourth value during charging of the battery by the power-supply circuit in the no-load condition and when the battery is in the substantially fully charged condition.

The charge status may also be computed in the case of self-discharging of the battery. The device is then characterized in that the computing means further comprise fifth adjusting means for adjusting a discharging time of the battery to a fifth value during discharging of the battery when the power-supply circuit and the load are inoperative. If the power-supply circuit is suitable for briefly supplying a relatively large charging current so as to recharge the battery after having been discharged almost completely, as rapidly as possible to such an extent that the load can be powered for at least one use, the device in another embodiment may be characterized in that the power-supply circuit is adapted to supply a charging current to the battery for a fraction of the charging time which charging current is larger than the charging current during the remainder of the charging time of the battery, and in that the computing means further comprise sixth adjusting means for adjusting a charging time of the battery to a sixth value during charging of the battery with an increased charging current when the load is inoperative and the battery is substantially empty.

A further embodiment of the invention may be characterized in that each of the adjusting means comprises a memory device for storing the adjusted value of the relevant adjusting means, in that the time-measuring means comprise:

an adjustable frequency divider for dividing the frequency of the clock pulses from the clock means depending on the value stored in the relevant adjusting means, and

a memory device having a fixed number of storage locations for the storage of the number of clock pulses supplied by the frequency divider, which number represents the computed charge status.

In this embodiment the charge status is determined by filling a non-volatile memory with clock pulses of variable frequency during charging and vacating this memory during discharging, the frequency of said clock pulses being dictated by the value stored in the relevant adjusting means and corrected by the correction means.

This embodiment may be characterized further

in that the first adjusting means comprise a first memory device for the storage of a first value, which represents the discharging time of the battery when discharged by the load,

in that the second adjusting means comprise a second memory device for the storage of the second value, which represents the charging time of the battery by the power-supply circuit, and

in that each of the other adjusting means comprises a memory device common to the first or second adjusting means, and means for connecting a fixed frequency divider in series with the programmable frequency divider.

Another embodiment of the invention may be characterized further

in that each of the adjusting means comprises a memory device for storing the adjusted value of the relevant adjusting means,

in that the time-measuring means comprise:

a memory device whose number of storage locations is proportional to the value stored in the relevant adjusting means and

a frequency divider for dividing the frequency of the clock pulses by a fixed number.

In this embodiment the charge status is determined in that a variable memory, whose storage capacity is dictated by the value stored in the relevant adjusting means and corrected by the correction means, is filled with clock pulses of a fixed frequency during charging and is vacated with clock pulses of a fixed frequency during discharging.

This embodiment may be characterized further

in that the first adjusting means comprise a memory device for storing the first value,

in that the second adjusting means comprise a memory device for storing the second value, and

in that each of the other adjusting means comprises a memory device common to the first or the second adjusting means for connecting a second fixed frequency divider in series with the said fixed frequency divider.

The indicator means of the device in accordance with the invention suitably comprises a passive electro-optical display device, in particular a liquid-crystal display device.

Embodiments of the invention will now be described in more detail, by way of example, with reference to the accompanying drawings, in which:

Fig. 1 shows a basic diagram of a device according to the invention,

Fig. 2 shows an extension of the diagram of Fig. 1,

Fig. 3 shows a first embodiment based on the circuit of Fig. 2,

Fig. 4 shows a second embodiment of the invention, and

Fig. 5 shows a third embodiment of the invention,

5 Fig. 6 shows a fourth embodiment of the invention.

Fig. 1 is the basic diagram of a device for indicating the charge status of a battery. The device comprises a power-supply circuit 1 with terminals 2 and 3 for applying a mains voltage, which may be an alternating voltage or a direct voltage. The power-supply circuit is, for example, a switched-mode power supply as known from British Patent Specification 2,000,394 or European Patent Application 30,026. A battery 4 is connected to the output of the power-supply circuit. In the present Application "battery" is to be understood to mean an assembly of one or more cells. In the present example the battery 4 comprises two nickel-cadmium cells connected in series. By means of a switch  $S_1$  a load  $R_L$  can be connected in parallel with the battery 4. This load  $R_L$  is, for example the motor of a dry-shaver. Furthermore, a device 7 is connected in parallel with the battery 4, to detect an actual charge status when the battery 4 is discharged. The device 7 detects for example whether the battery 4 is nearly empty by detecting a voltage level which corresponds to, for example, ten per cent of the nominal battery capacity. The device 7 comprises, for example, a comparator, which compares the battery voltage derived therefrom. It is to be noted that such detection devices are known *per se*, for example from United States Patent Specification 4,536,757 and from European Patent Application 115,625. When the mains voltage is applied and when the switch  $S_1$  is open the power-supply circuit 1 supplies the charging current for the battery 4, which condition will be referred to hereinafter as "battery charging". If the power-supply circuit 1 is not connected to the mains and the switch  $S_1$  is closed, the battery 4 supplies the supply current to the load  $R_L$ , which condition will be referred to hereinafter as "battery shaving". The device further comprises a number of means 8 to 15, whose supply voltages are furnished by the battery 4.

The device comprises control means 8 which on the basis of a signal providing information on whether the switch  $S_1$  is closed or not and a signal providing information on whether the power-supply circuit 1 is connected to the mains or not determines whether the battery-charging mode or the battery-shaving mode obtains.

The device also comprises computing means 9 comprising first adjusting means 10, second adjusting means 11 and time-measuring means 12. The first adjusting means 10 comprise a non-volatile and a volatile memory, the non-volatile memory containing a value, which dictates the nominal discharging time of the battery 4. When the device is put into use for the first time with a charged battery 4, each time when the device is put into use again after replacement of the battery, and in the case that the battery voltage decreases below the supply voltage required for the circuit elements, this value is stored in the volatile memory. The second adjusting means 11 only comprise a non-volatile memory, which stores a value dictating the nominal charging time of the battery 4. Depending on the battery shaving or battery charging mode detected by the control means 8, the value stored in the first or in the second adjusting means is applied to the time-measuring means 12. In the battery shaving and battery charging modes clock pulses are supplied to the time-measuring means 12 by clock means 13. From the number of clock pulses the time-measuring means 12 determine the fraction which the elapsed discharging and charging times form of the total discharging time and charging time stored in the adjusting means 10 and 11 respectively.

The fractions as calculated by the computing means 9 are indicated by an indicator means 14, which may comprise any passive or active indicator means or a combination thereof. The relevant information may be represented in any form, for example alphanumerically or segmentarily.

The indicator means may be constructed so as to indicate the charge status not only during operation of the device but also for a definite or indefinite time after switching-off of the device. In the lastmentioned case the charge status of the battery may be indicated, for example, by an electro-optical indicator means during operation of the device and by an electro-acoustic indicator means after switching off. The electro-acoustic indicator means may produce, for example, a number of acoustic signals in conformity with the charge status of the battery. Obviously, it is also possible to indicate the charge status only after the device has been switched off.

During discharging of the battery 4 in the battery-shaving mode the value which is stored in the volatile memory of the adjusting means 10 and which defines the discharging time of the battery 4 is applied to the time-measuring means 12. On the basis of the clock pulses supplied by the clock means 13 said means 12 express the discharging time which has elapsed as a fraction of the adjusted discharging time of the battery 4. This fraction forms the calculated charge status which is indicated by the indicator means 14.

The function as calculated by the computing means is also applied to the correction means 15. These means also receive a detection signal from the detection means 7, which, as mentioned above, detects when still a fraction of, say 10%, of the battery capacity is left during discharging of the battery 4. If for whatever reason the discharging current of the battery differs from the nominal discharging current, the residual fraction

as calculated by the computing means 12 deviates from the actual residual fraction of the battery capacity as signalled by the detection means 7. The correction circuit 15 then corrects the fraction calculated by the computing means 12 and hence also the indication by the indicator means 14. Moreover, the correction means 15 correct the value stored in the volatile memory of the adjusting means 10, which value determines the discharging time of the battery 4, in such a way that during the next discharge of the battery 4 the calculated charge status is better in conformity with the actual charge status of the battery 4.

It is to be noted that instead of a voltage level corresponding to 10% of the battery voltage the detection means 7 may detect any other voltage level. For example, the means 7 detect the voltage level corresponding to the fully discharged condition of the battery 4.

When the battery 4 is charged the value which is stored in the adjusting means 11 by the control means 8 and which defines the nominal charging time of the battery 4, is applied to the time-measuring means 12. If the fraction calculated by the time-measuring means 12 on the basis of the clock pulses from the clock means 13 is unity, i.e. after the adjusted charging time, the time-measuring means 12 generate a signal which stops the power-supply circuit 1. The indicator means 14 then indicates that the battery 4 is fully charged.

Starting from a nominal charging time and discharging time per charging and discharging cycle a calculated and indicated charge status are compared in the above-described way with the actual charge status during discharging, the adjusted discharging time being each time corrected in such a way that the calculated and the actual charge status are better in conformity with each other during the next charging and discharging cycle.

Fig. 2 shows an extension of the diagram of Fig. 1. The device does not only comprise a detection device 7 for detecting an actual charge status during discharging, but also a detection device 16 for detecting an actual charge status during charging of the battery 4. The detection device 16 comprises for example a means which detects whether the battery 4 is substantially fully charged. To achieve this several methods are known, such as detection of a specific battery voltage, detection of a maximum in the battery voltage by detecting a change of sign of the first derivative of the battery voltage with respect to time or by detecting a decrease of the battery voltage, detecting a change of sign of the second derivative of the battery voltage with respect to time or detecting a sudden temperature rise occurring when the battery is overcharged. Such methods are described in for example United States Patent Specification 4,392,101. Upon detection of the battery 4 being substantially fully charged the detection device 16 generates a signal which causes the power-supply circuit 1 to be disconnected.

The second adjusting means, like the first adjusting means 10 now comprise a non-volatile and a volatile memory, a value determining the nominal discharging time of the battery 4 being stored in the non-volatile memory. When the device is put into use for the first time, when it is put into use again after replacement of the battery 4, or after the electronic circuits have been inoperative due to too low a battery voltage, the value is transferred from the non-volatile memory into the volatile memory. During discharging of the battery 4 the device operates in the same way as described with reference to Fig. 1. During charging the value stored in the volatile memory of the adjusting means 11, which value determines the charging time of the battery 4, is applied to the time-measuring means 12 under control of the control means 8. On the basis of the clock pulses from the clock means 13 these means 12 express the elapsed charging time of the battery 4 as a fraction of the adjusted charging time of the battery 4. This fraction again forms the calculated charge status as indicated by the indicator means 14.

If the charging current deviates from the nominal charging current, the fraction calculated by the calculating means 12 does not correspond to the situation at the instant at which the detection means 16 detect that the battery 4 is substantially fully charged. In that case the correction circuit 15 corrects the calculated fraction, thereby also ensuring that the indicator means 14 indicates that the battery 4 is fully charged. Moreover, the correction means 15 correct the value stored in the volatile memory of the second adjusting means 11 which value denotes the charging time of the battery 4, in such a way that the next time that the battery 4 is charged the calculated charge status is better in conformity with the actual status of the battery 4.

Thus, the device of Fig. 2 compares a calculated and an indicated charge status with each other for each discharging and charging cycle both during charging and discharging, the adjusted charging and discharging times being corrected in the case of deviations in such a way that during the next discharging and charging cycle the calculated and the actual charge status are better in conformity with each other.

Fig. 3 shows an embodiment of the device in Fig. 2, identical parts bearing the same reference numerals.

The control means 8 comprise a first AND-gate 20 and a second AND-gate 21, each comprising an inverting input and non-inverting input. A signal which is high when the switch  $S_1$  is closed is applied to the non-inverting input of the gate 20 and to the inverting input of the gate 21 and a signal which is high when the power-supply circuit 1 is connected to the mains is applied to the inverting input of the gate 20 and to the non-inverting input of the gate 21. Consequently, the AND-gate 20 supplies a signal to the first adjusting means

10 in the battery-shaving mode and the AND-gate 21 supplies a signal to the second adjusting means 11 in the battery-charging mode.

5 The adjusting means 10 comprise a read-only memory 23 which stores a value which determines the nominal discharging time of the battery 4 and a read-write memory 24, into which the value from the read-only memory 23 is written by a reset pulse each time that the device becomes operative and into which a value corrected by the correction means 15 is written when the device is in operation. The manner in which the reset pulse is generated is not described for the sake of simplicity. The adjusting means 11 are constructed in the same way as the adjusting means 10 and comprise a read-only memory 25 in which a value is stored which  
10 represent the nominal charging time of the battery 4 and a read-write memory 26 into which the value from the read-only memory 25 is written when there is a reset pulse and into which a corrected value is written when the device is in operation. The read-only memories 23 and 25 comprise, for example, an aluminium conductor pattern, whereas the read-write memories 24 and 26 comprise, for example shift registers.

The computing means 12 comprise a memory in the form of a shift register 33, in the present example a  
15 13-bit register in which the calculated charge status is stored. During charging of the battery 4 clock pulses 32 from a frequency divider 30 are applied to the input 34 of the register via an OR-gate, which pulses each time increment the contents of the shift register by one bit. The situation in which the bits 1 to 10 contain a logic "1" corresponds to a fully charged battery. The bits 11, 12 and 13 are overflow bits, which will be discussed to below. During discharging of the battery 4 clock pulses from the frequency divider 30 are applied  
20 to an input 35 of the shift register 33 via an OR-gate, which pulses each time decrement the contents of the shift register by one bit. The frequency divider 20 is a programmable frequency divider in which the frequency of the clock pulses supplied by the clock means 13 is divided by a number which is stored in the read-write memory 24 of the first adjusting means 10 in the battery-shaving mode and is divided by a number which is stored in the read-write memory 26 of the second adjusting means 20 in the battery-charging mode. Such  
25 frequency dividers are known per se and are not described in more detail.

The clock means 13 comprise an oscillator for generating pulses and a number of fixed frequency dividers for deriving from these pulses the various clock frequencies required in the device. Similar clock means are well-known and therefore not described in more detail.

The correction means 15 comprise a flip-flop 51 which is triggered by a detection signal from the detection means 7. The output of said flip-flop is connected to an input of a NOR-gate 57 whose other input is connected to the first bit of the register 33 and whose output is connected to one input of an AND-gate 53, whose other input is connected to the clock means 13 and whose output is connected both to the count-up (+) input of the read-write memory 24 and to an input of the OR-gate 32, the output of said flip-flop 51 being also connected to a first input of an AND-gate 54, whose second input is connected to the second bit of the register 33, whose  
35 third input is connected to the clock means 13 and whose output is connected both to the count-down (-) input of the read-write memory 24 and to an input of the OR-gate 31. The correction means 51 further comprise a flip-flop 52 which is triggered by a detection signal from the detection means 16. Its output is connected to a first input of an AND-gate 56 whose second input is connected to the 11th bit of the register 33, whose third input is connected to the clock means 13 and whose output is connected both to the count-up (+) input of the read-write memory 26 and to the input of the OR-gate 31, the output of the flip-flop 52 being also connected to a first input of an AND-gate 55, whose second input is connected to the clock means 13, whose third input is connected to the output of an inverter 58 whose input is connected to the 10th bit of the register 33 and whose output is connected to both the count-down (-) input of the read-write memory 26 and to an input of the OR-gate 32.  
40

45 In the present embodiment the indicator means 14 comprises a liquid-crystal display means 40 with a bargraph with segment electrodes 41 to 45 and a back electrode 46. These electrodes 41 to 46 are driven by a driver circuit 47 in response to signals from the odd bits 1 to 9 of the shift register 33 of the computing means 12. The clock pulses for this driver circuit 47 are generated by the clock means 13. The segments 41 to 45 successively indicate the following charge statuses of the battery 4, again expressed in percentages of the  
50 battery capacity.

	Segment No.	%C
55	41	10—30
	42	30—50
	43	50—70
	44	70—90
	45	90—100

Moreover, the segment 41 starts to blink in the rhythm of a low-frequency clock signal applied to the driver circuit 47 by the clock means 13, if the driver circuit 47 receives a signal from the detection means 7 *via* the flip-flop 51 when the 10%-level is passed. It is also possible to represent the percentages separately or inscribed in the segments, for example in the sequence of 20, 40, 60, 80 and 100%. The indicator means further comprise a light-emitting diode (LED) 48 to indicate charging of the battery 4. This LED is driven by the signal on the inverting output of flip-flop 52. When the battery 4 is fully charged, the flip-flop 52 is triggered by the detection means 16, causing LED 48 to be turned off.

It is also possible to have the segment 45 blink when the battery 4 is almost fully charged in the same way as having the segment 41 blink when the battery is nearly empty.

It is also possible to provide the liquid-crystal display means 40 with extra electrodes in the form of letters and/or signs to indicate that the battery is nearly empty or nearly full or to indicate that the battery 4 is being charged or discharged.

The operation of the device may be explained as follows. It is assumed that the battery 4 is fully charged, the bits 1 to 10 of the register 33 containing a logic "1" and the segments 41 to 45 of the display means 40 being visible. When the power-supply circuit 1 is not connected to the mains the battery-shaving mode is obtained by closing the switch  $S_1$ . The AND-gate 20 of the control means 8 then supplies signal which causes the value stored in the read-write memory 24 to be applied to the programmable frequency divider 30. After a number of clock pulses from the clock means 13 as determined by this value, a clock pulse appears on an output of the frequency divider 30 and is applied to the input 35 of the register 33 via the OR-gate 31. This causes the 10th bit of the charging register 33 to change to a logic "0". With the next clock pulse generated by the frequency divider 30 the 9th bit changes to a logic "0", the top segment 45 of the display means 40 being turned off *via* the driver circuit 47. In this way the contents of the shift register 33 is each time decremented by one bit.

If the discharging current is larger and, consequently, the discharging time of the battery is shorter than the discharging time represented by the value in the read-write memory 24, the charging register 33 is decremented too slowly. At the instant at which the detection means 7 detects that the 10%-level is passed, a number of bits in the register 33 still contain a logic "1". It is assumed that the bits 1, 2 and 3 contain a "1". The "1" in the 2nd bit and the output signal of flip-flop 51 open the AND-gate 54, which causes a clock pulse to be applied to the input 35 of the register 33 via the OR-gate 31, which sets the 3rd bit to "0". The same clock pulse is applied to the count-down input of the read-write memory 24, which causes the value stored therein to be decremented by 1. The next clock pulse is also applied to the input 35 of the register 33 via the AND-gate 54 and the OR-gate 31, which causes the 2nd bit to be set to "0", said pulse also being applied to the count-down input of the memory 24, so that the value stored is again decremented by 1. Only the 1st bit of the charging register 33 now contains a logic "1", which is in agreement with the detection by the means 7. This correction also results in a correction of the indication of the liquid-crystal display means 40, so that the segment 41 will blink to indicate that the battery 4 is nearly empty.

Since the value of the number stored in the read-write memory 24 has been decreased, the calculated charge status will be better in conformity with the charge status during the next discharging period of the battery 4.

When the discharging current is smaller and the discharging time of the battery 4 is longer than the discharging time represented by the value in the read-write memory 24, the contents of the charging register 33 is decremented too fast. The 1st bit of register 33 is then set to "0" by a clock pulse from the frequency divider 30 before the passage of the 10%-level is detected by the detection means 7. In that case the AND-gate 53 is opened *via* the NOR-gate 57, which causes a clock pulse to be applied to the input 34 of the register 33 via the OR-gate 32, which sets the 1st bit to "1". This clock pulse is then applied to the count-up (+) input of the read-write memory 24, which causes the value stored therein to be incremented by "1". This is repeated until the flip-flop 51 is triggered by the detection means 7. Since the value of the number stored in the memory 24 has been incremented, the calculated charge status during the next discharging period will be better in conformity with the actual charge status of the battery 4.

For the explanation of the operation of the device during the charging process it is assumed that the battery 4 is nearly empty. When the power-supply circuit 1 is connected to the mains and the switch  $S_1$  is opened, the value stored in the read-write memory 26 is applied to the programmable frequency divider 30 via the AND-gate 21. After a number of clock pulses determined by this value the frequency divider 30 each time generates a clock pulse which is applied to the input 34 of the register 32 via the OR-gate 32, causing the contents of this register 33 to be incremented by one bit.

If the charging time of the battery 4 is shorter than the charging time represented by the value in the memory 26, the contents of the register 33 is incremented too slowly, so that at the instant at which the detection means 16 detects that the battery 4 is nearly fully charged the 10th bit of register 33 is still "0". This bit signal

is inverted by the inverter 58 and applied to the AND-gate 55, which also receives the output signal of the flip-flop 52, so that a clock pulse appears on the output of the AND-gate 55. This pulse is applied to the input 34 of the register 33 via the OR-gate 32, so that the contents of this register is incremented by one bit and said pulse is also applied to the count-down (-) input of the read-write memory 26, so that the value stored in this memory is decremented by one. This is repeated until the 10th bit of the register 33 is "1" in accordance with the full-detection by the means 16.

If the charging time of the battery 4 is longer than the charging time represented by the value in the memory 26, the contents of the register 33 is incremented too rapidly, so that at the instant at which the detection means 16 detects the fully charged condition one or more of the bits 11, 12 and 13 contain a logic "12". Triggering of the flip-flop 52 causes the AND-gate 56 to be opened, so that a clock pulse appears on its output. This pulse is applied to the input 35 of register 33 via the OR-gate 31, which causes the contents of this register to be decremented by one bit, said pulse being also applied to the count-up input of the read-write memory 26, which causes the value stored therein to be incremented. This is repeated until the 11th bit is "0".

The correction of the value stored in the memory 26 ensures that the calculated charge status is better in conformity with the actual charge status of the battery 4 during the next charging process.

Fig. 4 shows a second preferred embodiment based on the embodiment shown in Fig. 3, similar parts bearing the same reference numerals.

In the device of Fig. 3 a calculation of the charge status of the battery 4 is affected only in the battery-charging mode, in which the power-supply circuit 1 is connected to the mains and the switch  $S_1$  is closed and in the battery-shaving mode, in which the power-supply circuit 1 is not connected to the mains and the switch  $S_1$  is closed. In all the other possible modes no calculation and adaptation of the charge status is effected.

In the device of Fig. 4 the charge status of the battery is also calculated in these other modes. Moreover, in the device of Fig. 4 the power-supply circuit 1 is of the type that can charge the battery in the nearly empty condition with a relatively large charging current for a fixed time, so that the battery-shaving mode becomes available after a short lapse of time. Such a power-supply circuit is known from British Patent Application 2,125,641.

When the power-supply circuit 1 is connected to the mains and the switch  $S_1$  is closed, the power-supply circuit delivers a current to the load  $R_L$  and also a relatively small current to the battery 4 if the battery voltage is lower than the value at which the voltage across the motor  $R_L$  is stabilised. As a rule, this voltage is some tenths of volts lower than the battery voltage detected by the detection means 16 in the fully charged condition. When peak loads are ignored, the current supplied by the power-supply circuit 1 is generally larger than the current necessary to maintain the voltage across the motor  $R_L$  at the stabilised value. The battery 4 is charged by the difference between these currents. This condition is referred to as the mains-shaving mode. The device comprises third adjusting means 60 comprising a read-only memory 61 in which a value is stored which represents the charging time of the battery 4 in the mains-shaving mode. When this mode is detected by the control means 8 from the signal from the power-supply circuit 1 which indicates connection to the mains and from the signal indicating that the switch  $S_1$  is closed, the value stored in the memory 61 is applied to the programmable frequency divider 30. After a number of clock pulses of the clock means 13 determined by this value this frequency divider 30 each time generates a clock pulse, which is applied to the input 34 of register 33 via the OR-gate 32, causing the contents of the register to be incremented by one bit. When the battery voltage becomes equal to the stabilised motor voltage, the power-supply circuit 1 is rendered inoperative until the battery voltage has decreased below the stabilised motor voltage.

If in the battery-charging mode the nearly fully charged condition of the battery 4 is detected by the detection means 16, power-supply circuits of the type currently used change over to a trickle-charging mode, in which the battery 4 is charged with a relatively small trickle of charging current to keep the battery in the fully charged condition.

The device is provided with fourth adjusting means 62, comprising a read-only memory 63, in which a value is stored which represents the charging time of the battery 4 required for fully charging the battery with the trickle-charging current.

When the trickle-charging mode is detected by the control means 8 from the signals indicating the battery-charging mode and the output signal of the flip-flop 52, the power-supply circuit 1 is changed over to trickle charging by the control means 8 and the value stored in the memory 63 is applied to the frequency divider 30. After a number of clock pulses from the clock means 13 determined by this value this causes the frequency divider 30 to supply a clock pulse to the input 34 of the register 33 via the OR-gate 32, so that the contents of this register is each time incremented by one bit.

If the power-supply circuit 1 is not connected to the mains and the switch  $S_1$  is open, the battery 4 is drained slowly as a result of self-discharging. This condition is referred to hereinafter as "self-discharging". The device comprises fifth adjusting means 64 comprising a read-only memory 65, in which a value is stored, which rep-

represents the discharging time of the battery 4 in the case that it would be fully discharged by self-discharging. On detection of the self-discharging condition by the control means 8 the value stored in the memory 65 is applied to the programmable frequency divider 30. After a relatively large number of clock pulses from the clock means 13 this causes the frequency divider 30 to apply a clock pulse to the input 35 of register 33 via the OR-gate 31, so that the contents of this register is each time to be decremented by one bit.

As stated above, the power supply circuit 1 can supply a relatively large charging current. If the power-supply circuit 1 is connected to the mains, the switch  $S_1$  is closed and the flip-flop 51 has been triggered by the detection device 7 due to the battery 4 being nearly empty, the power-supply circuit 1 is changed over to the quick-charging mode by the control means 8. The power-supply circuit 1 then supplies a relatively large charging current for a relatively short time. During this time the battery 4 is charged to such an extent that energy is available for at least one shave. The device comprises sixth adjusting means 66 comprising a read-only memory 67 in which a value is stored which represents the charging time of the battery 4 in the case that it would be fully charged by the quick-charging current. In the quick-charging mode the value stored in memory 66 is applied to the frequency divider 30. After a relatively small number of clock pulses determined by this value this each time causes the frequency divider 30 to supply a clock pulse to the input 34 of register 33 via the OR-gate 32, so that the contents of this register is each time incremented by one bit.

At a given moment the battery voltage will decrease below the minimum supply voltage required for the electronic circuits when the battery 4 is discharged further after a passage of the 10%-level has been detected by the detection means, so that said circuits become inoperative. When the battery 4 is subsequently charged with the increased charging current, the device will become operative again above a certain battery voltage. The segment 41 of the indicator means 40 then blinks until the battery voltage has increased above the 10%-level.

It is to be noted that it is not necessary to apply all the adaptations of the calculation of the charge status of the battery as described with reference to Fig. 4. For example the influence of self-discharging of the battery on the charge status may be ignored if this self-discharging effect is very small. In such a case the read-only memory 64 may be dispensed with. It is also possible to combine the read-only memories 60 and 62 to form one memory if the charging current in the trickle-charging mode is of the same order of magnitude as in the mains-shaving mode.

Fig. 5 shows a device for indicating the charge status of a battery in accordance with a third embodiment, identical parts bearing the same reference numerals as in Fig. 4. The adjusting means 10 again comprise a read-only memory 23 in which a value representing the nominal discharging time of the battery is stored and a read-write memory 24 into which the value from the read-only memory 23 is entered each time that the device becomes operative and which during operation of the device stores a value corrected by the correction means 15. The adjusting means 11 are of the same construction as the adjusting means 10, the read-only memory 25 storing a value representing the nominal charging time of the battery 4 and the read-write memory 26 being loaded with the value from the read-only memory 25 when the device becomes operative and with a value corrected by the correction means 15 when the device is in operation. The computing means 12 again comprise a programmable frequency divider 30 and a register 33 which stores the computed charge status. In the present embodiment the register 33 is, for example, a 36-bit register. The indicator means 14 is of the same construction as that in the embodiment shown in Fig. 4, except that now the driver circuit 47 drives a succeeding segment electrode of the liquid-crystal display means 40 after every 8 clock pulses applied to the register 33 starting from the empty situation. In the present embodiment the segments 41 to 45 respectively correspond to 20, 40, 60, 80 and 100% of the battery capacity. The following Table gives the relationship between the contents of the register and the number of segment electrodes being driven.

	Number of bits stored in register	Segment No.
50	0—7	41
	8—15	41, 42
	16—23	41 to 43
	24—31	41 to 44
	32—36	41 to 45

55

The segment 41 moreover starts to blink in the rhythm of a low-frequency signal supplied to the driver circuit by the clock means 13 if upon passage of the 10%-level the detection means 7 supply a signal to the driver circuit via the flip-flop 51.

To explain the operation of the device in the battery-shaving mode it is assumed that the battery 4 is

fully charged so that the bits 0-36 of the register 33 contain a logic "1" and the segments 41 to 45 are driven. In the battery-shaving mode the value stored in the read-write memory 24 is transferred to the programmable frequency divider 30 in response to a signal from the control means 8. Moreover, the signal from the control means 8 is applied to an AND-gate 72, as a result of which clock pulses from the clock means 13 are applied to the programmable frequency divider 30. After a number of clock pulses determined by the value in the memory 24 a clock pulse is applied to the count-down input 35 of the register 33, so that the 36th bit changes to a logic "0". As is apparent from the above Table, the segments 45 of the display means 40 is turned off after five clock pulses from the divider 30 and subsequently a following segment is turned off after every eight clock pulses from the frequency divider 30. The clock pulses applied to the frequency divider 30 are also fed to a fixed frequency divider 84 via an AND-gate 83, which divider 84 divides the frequency of the incoming pulses by a value equal to the number of bit positions of the register 33, i.e. 36 in the present example. The output pulses of the frequency divider 84 are applied to a register 82. At the instant at which the detection means detects a passage of the 10%-level a signal from the flip-flop 51 causes the contents of the register 82 to be transferred to the read-write memory 24. When it is assumed that upon the detection of the 10%-level the contents of the register 33 is in conformity with this situation, i.e. all the 36 bit positions contain a logic "0", the value from the memory 24 applied to the frequency divider 30 is correct. It is then evident that the contents of the register 82 is the same as the contents of the memory 24. Therefore, the contents of the memory 24 is not corrected. If the discharging time of the battery 4 is now, for example, shorter than the discharging time represented by the value in the memory, the contents of the register is decremented too slowly. At the instant at which the detection means 7 detects a passage of the 10%-level some of the bits of the register 33 are still "1". By means of the flip-flop 51 all the bits of the register 33 are set to logic "0", so that the segment 41 starts to blink. Until this instant a number of pulses has been applied to the register 82, which is equal to the value from the memory 24 multiplied by the number of bits which are logic "0" expressed as a fraction of the total number of bits of the register 33. The contents of the register 82 is written into the read-write memory 24. In this way the value of the number stored in the read-write memory 24 is decremented, so that in the next discharging period of the battery 4 the contents of the register 33 is decremented more rapidly and, consequently, the computed and displayed charge status is better in conformity with the actual charge status.

To explain the operation of the device in the battery-charging mode it is assumed that the battery 4 is almost empty. Under control of the control means 8 the value stored in the read-write memory 26 is transferred to the programmable frequency divider 30. Clock pulses from the clock means 13, which for practical reasons are divided by means of a fixed frequency divider 70 are, applied to the input of the divider 30 via an AND-gate 71. After a number of clock pulses determined by the value from the memory 26, the frequency divider 30 supplies a clock pulse to the count-up input 34 of the register 34, so that the first bit changes to a logic "1". As a result of this the bottom segment 41 charges over from the blinking mode to the continuously turned-on mode. The segments 42 to 45 are driven each time that 8 clock pulses have been applied to the register 33.

The clock pulses applied to the frequency divider 30 are also applied to a fixed frequency divider 81 via an AND-gate 80, which divider 81 divides the frequency of the incoming pulses by a fixed value which in the present example is equal to 31. The output pulses of the frequency divider 81 are applied to the register 82. At the instant at which the detection means 16 detects the fully-charged level the contents of the register 82 is loaded into the read-write memory 26 in response to a signal from the flip-flop 52. If it is assumed that the charging time of the battery 4 is, for example, shorter than the discharging time represented by the value in the memory 26, the contents of the register 33 is incremented too slowly. Upon detection of the fully-charged level, some of the bits of the register 33 are still "0". By means of the flip-flop 52 all the bits of the register 33 are set to "1", so that all the segments of the display means 40 are driven. Until the detection of the fully charged level the register 82 has received a number of pulses equal to the value from the memory 26 multiplied by the number of bits with the logic "1" value expressed as a fraction of the value of the fixed frequency divider 81. As the contents of the register 82 is loaded into the memory 26, the contents of the register 33 is incremented more rapidly the next time that the battery is charged, so that the computed charge-status is then better in conformity with the actual charge status.

The adjusting means which establish the charging or discharging time of the battery 4 in the other charging and discharging modes which are possible comprise a memory common to the first adjusting means 11 or the second adjusting means 12.

The adjusting means for the self-discharging mode comprise the first adjusting means 10 and a fixed frequency divider 78 connected in series with the programmable frequency divider 30. In the self-discharging mode the value from the read-write memory 24 is applied to the frequency divider 30 under control of the control means 8. By means of an AND-gate 77 clock pulses from the clock means 13 are applied to the frequency divider 78 and subsequently to the frequency divider 30, so that after a number of clock pulses determined by the value from the memory 24 the contents of the charge register 33 is adapted and the value stored in

the memory 24 is not corrected. The charging time of the battery 4 defined by the adjusting means for the self-discharging mode is modified by a correction of the value stored in the memory 24 for the battery-shaving mode.

5 The adjusting means for the quick-charging mode comprise the second adjusting means 11 and a fixed frequency divider 74 connected in series with the programmable frequency divider 30. In the quick-charging mode the value from the memory 26 is transferred to the programmable frequency divider 30. Clock pulses from the clock means 13 are applied to the frequency divider 74 *via* the AND-gate 73 and subsequently to the frequency divider 30, so that the contents of the register 33 is incremented each time after a number of clock  
10 pulses determined by the value from the memory 26. In a similar way, the adjusting means for the mains-shaving mode and trickle-charging mode comprise the second adjusting means 11 and the fixed frequency dividers 76 and 79 respectively. In the mains-shaving mode clock pulses are applied to the frequency divider 76 *via* the AND-gate 75 and in the trickle-charging mode these pulses are applied to the frequency divider 79 *via* the AND-gate 87, so that the contents of the register 33 is also adapted in these modes.

15 It is to be noted that in the embodiments described the functions performed by the circuits 8, 10, 11, 12, 14 and 15 may be realized by means of a microprocessor.

Fig. 6 shows a fourth embodiment of the invention in which the functions of the control means, the adjusting means, the computing means and the correction means are performed by a microprocessor. The microprocessor is for example of the type Toshiba M 50.760-XXXP. This microprocessor requires a minimum supply  
20 voltage of 2 V, which is delivered by the battery 4. For the sake of simplicity the external components necessary for a correct operation of the microprocessor are not shown.

The display means 40 again comprises 5 segment electrodes 41 to 45. In the present example the segment electrode 41 displays fixed information in the form of the letters RECH, which denotes the fully discharged state of the battery 4 and, consequently, the need to recharge the battery 4. Above the segment electrode  
25 45 a number of electrodes forming the words FULL are arranged, which when driven indicate that the battery is charged to substantially the full extent.

In the present example, the full battery capacity is divided in accordance with the scales -10, 0, 20, 40, 60, 80 and 100%. In this scale the segment electrodes 41 to 45, in this order, denote the ranges 0-20; 20-40; 40-60; 60-80 and 80-100%. In this scale the 0%-level corresponds to the condition in which the detection  
30 means 7 detect the level of 10% of the full battery capacity. When this level is detected the segment electrode 41 will blink. When the battery 4 is discharged even further, this segment electrode 41 keeps blinking until the voltage level is reached below which the display means 40 no longer functions. This voltage level corresponds to the -10%-level. At this level the fixed information RECH is displayed as a sign that the battery 4 must be recharged. In the present embodiment the detection means 16 detects a voltage level which on the  
35 display-means scale corresponds to the 80%-level. When this level is reached the charging current of the circuit 1 is set to the slow-charging level to charge the battery 4 completely within a predetermined time. When this level is detected all the segment electrodes and the FULL indication are driven. However, for computing, the charge status the micro-processor 9 proceeds with the 80%-level. If the computed charge status is already higher prior to detection of the 80%-level, the display means continues to display the 80%-level until this level  
40 is detected.

A first read-only memory in the microprocessor 90 stores a value representing 1/10 of the nominal discharging time. When the device becomes operative in the battery-shaving mode this value is loaded into a counter formed by a part of the memory. This counter then counts down with clock pulses of a fixed frequency  
45 derived from the internal clock of the microprocessor. The processor also comprises a charge register storing a number which may have values from 0 to 9. This value represents the computed charge status, which is displayed by the display means 40. When it is assumed that the battery 4 is fully charged, i.e. the charge register contains the number 9, the charge register is set to 8 after the counter has counted down to zero. Subsequently, the value from the first read-only memory is each time again applied to the counter, after which it counts down again until it is empty. If the detection means 7 detects the 10%-level and the state of the charge  
50 register is unequal to zero at this instant, the processor computes a new value from the old values and the state of the charge register, which new values represents 1/10 of the discharging time. This new value is written into a first read-write register and is transferred to the counter during the next discharging process.

A second read-only memory in the microprocessor stores a value which represents 1/10 of the nominal charging time. In the battery-charging mode this value is applied to the counter when the device becomes  
55 operative, which counter again counts down until it is empty with clock pulses of a fixed frequency derived from the internal clock. When it is assumed that the battery 4 is almost empty, i.e. position 0 of the charge register, the charge register is now set to position 1. In this way the value stored in the second read-only memory is each time transferred to the counter in the battery-charging mode, which counter each time counts down until it is empty, resulting in the contents of the charge register being incremented by one each time. If the

detection means 16 detects the 80% level and at this instant the state of the charge register is not 7, the processor derives a new value representing 1/10 of the charging time from the old value and the state of the charge register. This new value is entered into a read-write memory. The next time that the battery 4 is charged, this value is each time applied to the counter. Adaptation of the computed charge status in the quick-charging, trickle-charging, mains-shaving and self-discharging modes can be realized simply in the present embodiment by vacating the counters with clock pulses of a different frequency.

The invention is not limited to the embodiments described herein, many modifications being conceivable to those skilled in the art within the scope of the invention. In the embodiments described the computed charge status during discharging and/or charging of the battery is compared with one actual charge status, after which the computed charge status is corrected. However, it is also possible to compare, and if necessary correct, the computed charge status during charging and/or discharging several times with an actual charge status.

## Claims

1. A device for indicating the charge status of a battery (4) during charging and/or discharging, comprising:
  - a power-supply circuit (1) for charging the battery (4) and/or energizing a load ( $R_L$ );
  - clock means (13) for generating clock pulses during charging and/or discharging of the battery (4);
  - computing means (9) for computing the charge status on the basis of the generated clock pulses;
 and
  - indicator means (14) for indicating the computed charge status, characterized in that:
    - the computing means (9) comprise:
      - first adjusting means (10) for adjusting a discharging time of the battery (4) to a first value during discharging of the battery (4) by the load ( $R_L$ ) and/or second adjusting means (11) for adjusting a charging time of the battery (4) to a second value during charging of the battery (4) by the power-supply circuit (1) under no-load condition, and
      - time-measuring means (12) for determining, on the basis of the generated clock pulses alone, the ratio between the elapsed discharging time and said first value representing the adjusted discharging time and/or for determining the ratio between the elapsed charging time and said second value representing the adjusted charging time, which ratios represent the computed charge status,
      - and in that the device further comprises: detection means (7, 16) for detecting at least one actual charge status of the battery (4) during virtually every discharging and/or virtually every charging cycle of the battery (4),
      - correction means (15) for correcting the computed charge status and for correcting the first value of the first adjusting means (10) and/or the second value of the second adjusting means (11) when a difference occurs between said at least one actual charge status detected by the detection means (7) and the computed charge status at the instant of detection, and
      - control means (8) for controlling the first and/ or second adjusting means (10, 11) and time-measuring means (12).
2. A device as claimed in Claim 1, characterized in that the detection means (7, 16) for detecting said at least one actual charge status during discharging of the battery (4) comprise a first detection device for detecting a decrease of the battery voltage below a reference voltage.
3. A device as claimed in Claim 1, characterized in that the detection means (7, 16) for detecting said at least one actual charge status during charging of the battery (4) comprise a second detection device for detecting the substantially fully charged condition of the battery (4).
4. A device as claimed in Claim 3, characterized in that the second detection device comprises a device for detecting a battery-voltage decrease which occurs when the battery (4) is in the substantially fully charged condition.
5. A device as claimed in Claim 3, characterized in that the second detection device comprises a device for detecting whether the battery voltage is equal to a reference voltage.
6. A device as claimed in any one of the preceding Claims, characterized in that the computing means (9) further comprises third adjusting means (60) for adjusting a charging time of the battery (4) to a third value during charging of the battery (4) by the power-supply circuit (1) in its loaded condition.

- 5 7. A device as claimed in any one of the preceding Claims, characterized in that the computing means (9) further comprises fourth adjusting means (62) for adjusting a charging time of the battery (4) to a fourth value during charging of the battery (4) by the power-supply circuit (1) in the no-load condition and when the battery (4) is in the substantially fully charged condition.
- 10 8. A device as claimed in any one of the preceding Claims, characterized in that the computing means (9) further comprise fifth adjusting means (64) for adjusting a discharging time of the battery (4) to a fifth value during discharging of the battery (4) when the power supply circuit (1) and the load ( $R_L$ ) are inoperative.
- 15 9. A device as claimed in any one of the preceding Claims, characterized in that the power-supply circuit (1) is adapted to supply a charging current to the battery (4) for a fraction of the charging time, which charging current is larger than the charging current during the remainder of the charging time of the battery (4), and in that the computing means (9) further comprise sixth adjusting means (66) for adjusting a charging time of the battery (4) to a sixth value during charging of the battery (4) with an increased charging current when the load ( $R_L$ ) is inoperative and the battery (4) is substantially empty.
- 20 10. A device as claimed in any one of the preceding Claims, characterized  
in that each of the adjusting means 10, 11, 60, 62, 64, 66) comprises a memory device (24, 26, 61, 63, 65, 67) for storing the adjusted value of the relevant adjusting means,  
in that the time-measuring means (12) comprise:  
an adjustable frequency divider (36) for dividing the frequency of the clock pulses from the clock means (13) depending on the value stored in the relevant adjusting means, and  
25 a memory device (33) having a fixed number of storage locations for the storage of the number of clock pulses supplied by the frequency divider (30), which number represents the computed charge status.
- 30 11. A device as claimed in Claim 10 when appendant to any one of the Claims 6 to 9, characterized  
in that the first adjusting means (10) comprise a first memory device (24) for the storage of a first value, which represents the discharging time of the battery (4) when discharged by the load ( $R_L$ ),  
in that the second adjusting means (11) comprise a second memory device (26) for the storage of the second value, which represents the charging time of the battery (4) by the power-supply circuit (1),  
and  
35 in that each of the other adjusting means comprises a memory device common (24, 26) to the first or second adjusting means (10, 11) and means (73, 75, 77, 87) for connecting a fixed frequency divider (74, 76, 78) in series with the programmable frequency divider (30).
- 40 12. A device as claimed in any one of the Claims 1 to 9, characterized  
in that each of the adjusting means (10, 11, 60, 62, 64, 66) comprises a memory device (24, 26, 61, 63, 65, 67) for storing the adjusted value of the relevant adjusting means,  
in that the time-measuring means (12) comprise:  
a memory device whose number of storage locations is proportioned to the value stored in the relevant adjusting means, and  
45 a frequency divider for dividing the frequency of the clock pulses by a fixed number.
- 50 13. A device as claimed in Claim 12, when appendant to any one of the Claims 6 to 8, characterized  
in that the first adjusting means (10) comprise a memory device for storing the first value,  
in that the second adjusting means (11) comprise a memory device for storing the second value,  
and  
in that each of the other adjusting means (60, 62, 64, 66) comprises a memory device common to the first or the second adjusting means for connecting a second fixed frequency divider in series with the said fixed frequency divider.
- 55 14. A device as claimed in any one of the preceding Claims, characterized in that the indicator means (14) comprise a passive electro-optical display means.
15. A device as claimed in Claim 14, characterized in that the indicator means (14) comprise a liquid-crystal display means.

16. A device as claimed in any one of the preceding Claims, characterized in that the indicator means (14) comprise an electro-acoustic indicator means.
- 5 17. A device as claimed in any one of the preceding Claims, characterized in that the indicator means (14) comprise means for indicating the charge status of the battery after the device has been switched off.
18. A dry-shaving apparatus, characterized in that it comprises a device as claimed in any one of the preceding Claims.

10

### Patentansprüche

1. Anordnung zum Anzeigen des Ladungszustands einer Batterie (4) beim Laden und/oder Entladen, mit einer Speiseschaltung zum Laden und/oder Versorgen einer Belastung ( $R_L$ ), Taktgebermitteln (13) zum Erzeugen von Taktimpulsen beim Laden und/oder Entladen der Batterie (4),  
 15 Berechnungsmitteln (9) zum Berechnen des Ladungszustands auf Basis der erzeugten Taktimpulse, und  
 20 Anzeigemitteln (14) zum Anzeigen des berechneten Ladungszustands, dadurch gekennzeichnet, daß  
 die Berechnungsmittel (9) folgende Elemente  
 erste Einstellmittel (10) zum Einstellen einer Entladezeit der Batterie (4) auf einen ersten Wert beim Entladen der Batterie (4) durch die Belastung ( $R_L$ ) und/oder zweite Einstellmittel (11) zum Einstellen einer Aufladezeit der Batterie (4) auf einen zweiten Wert beim Laden der Batterie (4) durch die Speiseschaltung (1) bei abgeschalteter Belastung, und  
 25 Zeitmeßmittel (12) zum Feststellen, nur auf Basis der erzeugten Taktimpulse, des Verhältnisses der abgelaufenen Entladezeit und diesem ersten Wert, der die eingestellte Entladezeit darstellt, und/oder zum Feststellen des Verhältnisses der abgelaufenen Ladezeit und diesem zweiten Wert, der die eingestellte Ladezeit darstellt, wobei diese Verhältnisse den berechneten Ladungszustand darstellen, und  
 30 außerdem folgende Elemente enthalten,  
 Detektormittel (7, 16) zum Detektieren wenigstens eines wirklichen Ladungszustands der Batterie (4) bei nahezu jedem Entladezyklus und/oder nahezu jedem Aufladezyklus der Batterie (4),  
 Korrekturmittel (15) zum Korrigieren des berechneten Ladungszustands und zum Korrigieren des ersten Werts der ersten Einstellmittel (10) und/oder des zweiten Werts der zweiten Einstellmittel (11) beim Auftreten eines Unterschieds zwischen dem von den Detektormitteln (7) detektierten wenigstens einen wirklichen Ladungszustand und dem berechneten Ladungszustand zum Zeitpunkt der Detektion, und  
 35 Steuermittel (8) zum Steuern der ersten und/ oder zweiten Einstellmittel (10, 11) und der Zeitmeßmittel (12).
2. Anordnung nach Anspruch 1, dadurch gekennzeichnet, daß die Detektormittel (7, 16) zum Detektieren des wenigstens einen wirklichen Ladungszustands beim Entladen der Batterie (4) mit einer ersten Detektoreinrichtung zum Detektieren eines Abfalls in der Batteriespannung unter einer Bezugsspannung  
 45 versehen ist.
3. Anordnung nach Anspruch 1, dadurch gekennzeichnet, daß die Detektormittel (7, 16) zum Detektieren des wenigstens einen wirklichen Ladungszustands beim Aufladen der Batterie (4) mit einer zweiten Detektoreinrichtung zum Detektieren des im wesentlichen voll aufgeladenen Zustands der Batterie (4) versehen ist.  
 50
4. Anordnung nach Anspruch 3, dadurch gekennzeichnet, daß die zweite Detektoreinrichtung eine Einrichtung zum Detektieren eines Abfalls in der Batteriespannung enthält, der im nahezu voll geladenen Zustand der Batterie (4) auftritt.
5. Anordnung nach Anspruch 3, dadurch gekennzeichnet, daß die zweite Detektoreinrichtung eine Einrichtung zum Detektieren der Gleichheit der Batteriespannung und einer Bezugsspannung enthält.  
 55
6. Anordnung nach einem oder mehreren der vorangehenden Ansprüche, dadurch gekennzeichnet, daß das Berechnungsmittel (9) weiter dritte Einstellmittel (60) zum Einstellen einer Ladezeit der Batterie (4) auf

einen dritten Wert beim Laden der Batterie (4) durch die Speiseschaltung (1) bei eingeschalteter Belastung enthält.

- 5 7. Anordnung nach einem oder mehreren der vorangehenden Ansprüche, dadurch gekennzeichnet, daß das Berechnungsmittel (9) vierte Einstellmittel (62) zum Einstellen einer Ladezeit der Batterie (4) auf einen vierten Wert beim Laden der Batterie (4) durch die Speiseschaltung (1) bei einer nahezu voll geladenen Batterie (4) sowie bei abgeschalteter Belastung enthält.
- 10 8. Anordnung nach einem oder mehreren der vorangehenden Ansprüche, dadurch gekennzeichnet, daß das Berechnungsmittel (9) fünfte Einstellmittel (64) zum Einstellen einer Entladezeit der Batterie (4) auf einen fünften Wert beim Entladen der Batterie (4) bei abgeschalteter Speiseschaltung (1) sowie bei abgeschalteter Belastung ( $R_L$ ) enthält.
- 15 9. Anordnung nach einem oder mehreren der vorangehenden Ansprüche, dadurch gekennzeichnet, daß die Speiseschaltung (1) sich zum Liefern eines Ladestroms an die Batterie (4) während eines Bruchteils der Ladezeit eignet, und dieser Ladestrom größer ist als der Ladestrom in der weiteren Ladezeit der Batterie (4), und daß das Berechnungsmittel (9) sechste Einstellmittel (66) zum Einstellen einer Ladezeit der Batterie (4) auf einen sechsten Wert beim Laden der Batterie (4) mit einem erhöhten Ladestrom bei abgeschalteter Belastung ( $R_L$ ) sowie bei einer fast leeren Batterie (4) enthält.
- 20 10. Anordnung nach einem oder mehreren der vorangehenden Ansprüche, dadurch gekennzeichnet, daß jedes der Einstellmittel (10, 11, 60, 62, 64, 66) einen Speicher (24, 26, 61, 63, 65, 67) zum Speichern des eingestellten Werts der betreffenden Einstellmittel enthält, daß die Zeitmeßmittel (12)
- 25 einen einstellbaren Frequenzteiler (36) zum Teilen der Frequenz der Taktimpulse aus den Taktgebermitteln (13) in Abhängigkeit von dem in den betreffenden Einstellmitteln gespeicherten Wert, und einen Speicher (33) mit einer festen Anzahl von Speicherstellen zum Speichern der Anzahl vom Frequenzteiler (30) gelieferter Taktimpulse enthalten, wobei die Anzahl den berechneten Ladungszustand darstellt.
- 30 11. Anordnung nach Anspruch 10, in Abhängigkeit von einem der Ansprüche 6 bis 9, dadurch gekennzeichnet, daß
- 35 die ersten Einstellmittel (10) einen ersten Speicher (24) zum Speichern des ersten Werts enthalten, der die Entladezeit der Batterie (4) bei Entladung durch die Belastung festlegt,
- die zweiten Einstellmittel (11) einen zweiten Speicher (26) zum Speichern des zweiten Werts enthalten, der die Ladezeit der Batterie (4) durch die Speiseschaltung (1) festlegt, und daß
- jedes der übrigen Einstellmittel einen den ersten oder zweiten Einstellmitteln (10, 11) gemeinsamen Speicher (24, 26) und Mittel (73, 75, 77, 87) zum Reihenschalten eines festen Frequenzteilers (74, 76, 78) mit dem programmierbaren Frequenzteiler (30) enthält.
- 40 12. Anordnung nach einem der vorangehenden Ansprüche 1 bis 9, dadurch gekennzeichnet, daß jedes der Einstellmittel (10, 11, 60, 62, 64, 66) einen Speicher (24, 26, 61, 63, 65, 67) zum Speichern des eingestellten Werts der betreffenden Einstellmittel enthält, daß die Zeitmeßmittel (12)
- 45 einen Speicher, dessen Anzahl von Speicherstellen dem in den betreffenden Einstellmitteln gespeicherten Wert proportional ist, und einen Frequenzteiler zum Teilen der Frequenz der Taktimpulse durch eine feste Zahl enthalten.
- 50 13. Anordnung nach Anspruch 12, in Abhängigkeit von einem der Ansprüche 6 bis 8, dadurch gekennzeichnet, daß
- die ersten Einstellmittel (10) einen Speicher zum Speichern des ersten Werts enthalten,
- die zweiten Einstellmittel (11) einen Speicher zum Speichern des zweiten Werts enthalten, und daß
- jedes der übrigen Einstellmittel (60, 62, 64, 66) einen den ersten oder zweiten Einstellmitteln (10, 11) gemeinsamen Speicher und Mittel zum Reihenschalten eines zweiten festen Frequenzteilers mit dem festen Frequenzteiler enthält.
- 55 14. Anordnung nach einem oder mehreren der vorangehenden Ansprüche, dadurch gekennzeichnet, daß die Anzeigemittel (14) eine passive elektrooptische Anzeigeanordnung enthalten.

15. Anordnung nach Anspruch 14, dadurch gekennzeichnet, daß die Anzeigemittel (14) eine Flüssigkristallanordnung enthalten.
- 5 16. Anordnung nach einem oder mehreren der vorangehenden Ansprüche, dadurch gekennzeichnet, daß die Anzeigemittel (14) ein elektroakustisches Anzeigemittel enthalten.
17. Anordnung nach einem oder mehreren der vorangehenden Ansprüche, dadurch gekennzeichnet, daß die Anzeigemittel (14) Mittel zum Anzeigen des Ladungszustands der Batterie (4) nach dem Abschalten des Geräts enthalten.
- 10 18. Trockenrasierer, dadurch gekennzeichnet, daß er mit einer Anordnung nach einem oder mehreren der vorangehenden Ansprüche ausgerüstet ist.

15 **Revendications**

1. Dispositif pour indiquer l'état de charge d'une batterie (4) pendant la charge et/ou la décharge, comprenant:
- 20 un circuit d'alimentation électrique (1) pour charger la batterie (4) et/ou exciter un dispositif consommateur ( $R_L$ );  
 une horloge pour produire des impulsions d'horloge pendant la charge et/ou la décharge de la batterie (4);  
 des moyens de calcul (9) pour calculer l'état de charge sur base des impulsions d'horloge produites, et
- 25 un moyen indicateur (14) pour indiquer l'état de charge calculé; caractérisé en ce que:  
 les moyens de calcul (9) comprennent:  
 un premier moyen de réglage (10) pour régler un temps de décharge de la batterie (4) sur une première valeur pendant la décharge de la batterie (4) par le dispositif consommateur ( $R_L$ ) et/ou un deuxième moyen de réglage (11) pour régler un temps de charge de la batterie (4) sur une deuxième valeur pendant la charge de la batterie (4) par le circuit d'alimentation électrique (1) en l'absence de dispositif consommateur, et des moyens de mesure du temps (12) pour déterminer, uniquement sur base des impulsions d'horloge produites, le rapport entre le temps de décharge écoulé et le temps de décharge réglé et/ou pour déterminer le rapport entre le temps de charge écoulé et le temps de charge réglé, ces rapports représentant l'état de charge calculé;
- 30 et en ce que le dispositif comprend, en outre:  
 des moyens de détection (7, 16) pour détecter au moins un état de charge réel de la batterie (4) pendant virtuellement chaque cycle de décharge et/ou virtuellement chaque cycle de charge de la batterie (4); des moyens de correction (15) pour corriger l'état de charge calculé et pour corriger la première valeur du premier moyen de réglage (10) et/ou la deuxième valeur du deuxième moyen de réglage (11) lorsqu'une différence apparaît entre ledit au moins un état de charge réel détecté par les moyens de détection (7) et l'état de charge calculé à l'instant de la détection, et un moyen de commande (8) pour commander le premier et/ou le deuxième moyen de réglage (10, 11) et les moyens de mesure du temps (12).
- 35 2. Dispositif suivant la revendication 1, caractérisé en ce que les moyens de détection (7, 16) destinés à détecter ledit au moins un état de charge réel pendant la décharge de la batterie (4) comprennent un premier dispositif détecteur pour la détection d'une diminution de la tension de la batterie en dessous d'une tension de référence.
- 40 3. Dispositif suivant la revendication 1, caractérisé en ce que les moyens de détection (7, 16) destinés à détecter ledit au moins un état de charge pendant la charge de la batterie (4) comprennent un deuxième dispositif détecteur pour la détection de l'état en substance complètement chargé de la batterie (4).
- 45 4. Dispositif suivant la revendication 3, caractérisé en ce que le deuxième dispositif détecteur comprend un dispositif pour la détection d'une diminution de la tension de la batterie qui se produit lorsque la batterie (4) se trouve dans l'état en substance complètement chargé.
- 50 5. Dispositif suivant la revendication 3, caractérisé en ce que le deuxième dispositif détecteur comprend un dispositif pour détecter si la tension de la batterie est égale à une tension de référence.
- 55

- 5 6. Dispositif suivant l'une quelconque des revendications précédentes, caractérisé en ce que les moyens de calcul (9) comprennent, en outre, un troisième moyen de réglage (60) pour régler un temps de charge de la batterie (4) sur une troisième valeur pendant la charge de la batterie (4) par le circuit d'alimentation électrique (1) dans son état avec le dispositif consommateur actif.
- 10 7. Dispositif suivant l'une quelconque des revendications précédentes, caractérisé en ce que les moyens de calcul (9) comprennent, en outre, un quatrième moyen de réglage (62) pour régler un temps de charge de la batterie (4) sur une quatrième valeur pendant la charge de la batterie (4) par le circuit d'alimentation électrique (1) dans l'état sans dispositif consommateur ainsi que lorsque la batterie (4) se trouve dans l'état en substance complètement chargé.
- 15 8. Dispositif suivant l'une quelconque des revendications précédentes, caractérisé en ce que les moyens de calcul (9) comprennent, en outre, un cinquième moyen de réglage (64) pour régler un temps de décharge de la batterie (4) sur une cinquième valeur pendant la décharge de la batterie (4) lorsque le circuit d'alimentation électrique (1) et le dispositif consommateur ( $R_L$ ) sont inactifs.
- 20 9. Dispositif suivant l'une quelconque des revendications précédentes, caractérisé en ce que le circuit d'alimentation électrique (1) est à même de fournir à la batterie (4), pendant une fraction de temps de charge, un courant de charge qui est plus intense que le courant de charge fourni pendant le reste du temps de charge de la batterie (4), et en ce que les moyens de calcul (9) comprennent, en outre, un sixième moyen de réglage (66) pour régler un temps de charge de la batterie (4) sur une sixième valeur pendant la charge de cette batterie (4) au moyen d'un courant de charge accru lorsque le dispositif consommateur ( $R_L$ ) est inactif et que la batterie (4) est en substance vide.
- 25 10. Dispositif suivant l'une quelconque des revendications précédentes, caractérisé:  
 en ce que chacun des moyens de réglage (10, 11, 60, 62, 64, 66) comprend un dispositif à mémoire (24, 26, 61, 63, 65, 67) pour stocker la valeur réglée du moyen de réglage en question;  
 en ce que les moyens de mesure du temps (12) comprennent:  
 un diviseur de fréquence réglable (36) pour diviser la fréquence des impulsions d'horloge de  
 30 l'horloge (13) en fonction de la valeur stockée dans le moyen de réglage en question, et  
 un dispositif à mémoire (33) comportant un nombre fixe d'emplacements pour le stockage du nombre d'impulsions d'horloge fournies par le diviseur de fréquence (30), ce nombre représentant l'état de charge calculé.
- 35 11. Dispositif suivant la revendication 10 découlant de l'une quelconque des revendications 6 à 9, caractérisé:  
 en ce que le premier moyen de réglage (10) comprend une première mémoire (24) pour le stockage d'une première valeur, qui représente le temps de décharge de la batterie (4) lorsqu'elle est déchargée par le dispositif consommateur ( $R_L$ );  
 en ce que le deuxième moyen de réglage (11) comprend une deuxième mémoire (26) pour le  
 40 stockage de la deuxième valeur, qui représente le temps de charge de la batterie (4) par le circuit d'alimentation électrique (1), et  
 en ce que chacun des autres moyens de réglage comprend une mémoire (24, 26) commune au premier ou au deuxième moyen de réglage (10, 11) et des moyens (73, 75, 77, 87) pour connecter un diviseur de fréquence fixe (74, 76, 78) en série avec le diviseur de fréquence programmable (30).
- 45 12. Dispositif suivant l'une quelconque des revendications 1 à 9, caractérisé:  
 en ce que chacun des moyens de réglage (10, 11, 62, 64, 66) comprend une mémoire (24, 26, 61, 63, 65, 67) destinée à stocker la valeur réglée du moyen de réglage en question;  
 en ce que les moyens de mesure du temps (12) comprennent:  
 50 une mémoire dont le nombre d'emplacements de stockage est proportionnel à la valeur stockée dans le moyen de réglage en question, et  
 un diviseur de fréquence pour diviser la fréquence des impulsions d'horloge par un nombre fixe.
- 55 13. Dispositif suivant la revendication 12, découlant de l'une quelconque des revendications 6 à 8, caractérisé:  
 en ce que le premier moyen de réglage (10) comprend une mémoire pour le stockage de la première valeur;  
 en ce que le deuxième moyen de réglage (11) comprend une mémoire pour le stockage de la deuxième valeur, et

en ce que chacun des autres moyens de réglage (60, 62, 64, 66) comprend une mémoire commune au premier ou au deuxième moyen de réglage pour connecter un deuxième diviseur de fréquence fixe en série avec ledit diviseur de fréquence fixe.

5

**14.** Dispositif suivant l'une quelconque des revendications précédentes, caractérisé en ce que le moyen indicateur (14) comprend un dispositif d'affichage électrooptique passif.

10

**15.** Dispositif suivant la revendication 14, caractérisé en ce que le moyen indicateur (14) comprend un dispositif d'affichage à cristaux liquides.

**16.** Dispositif suivant l'une quelconque des revendications précédentes, caractérisé en ce que le moyen indicateur (14) comprend un dispositif indicateur électroacoustique.

15

**17.** Dispositif suivant l'une quelconque des revendications précédentes, caractérisé en ce que le moyen indicateur (14) comprend un dispositif pour indiquer l'état de charge de la batterie après que le dispositif a été éteint.

20

**18.** Appareil de rasage à sec, caractérisé en ce qu'il comprend un dispositif suivant l'une quelconque des revendications précédentes.

25

30

35

40

45

50

55

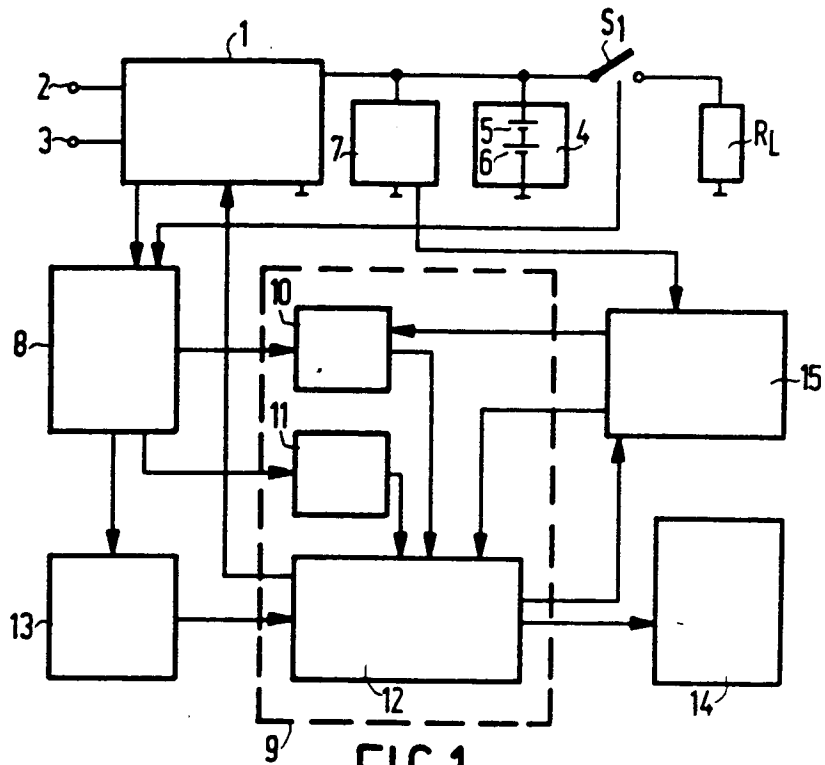

FIG. 1

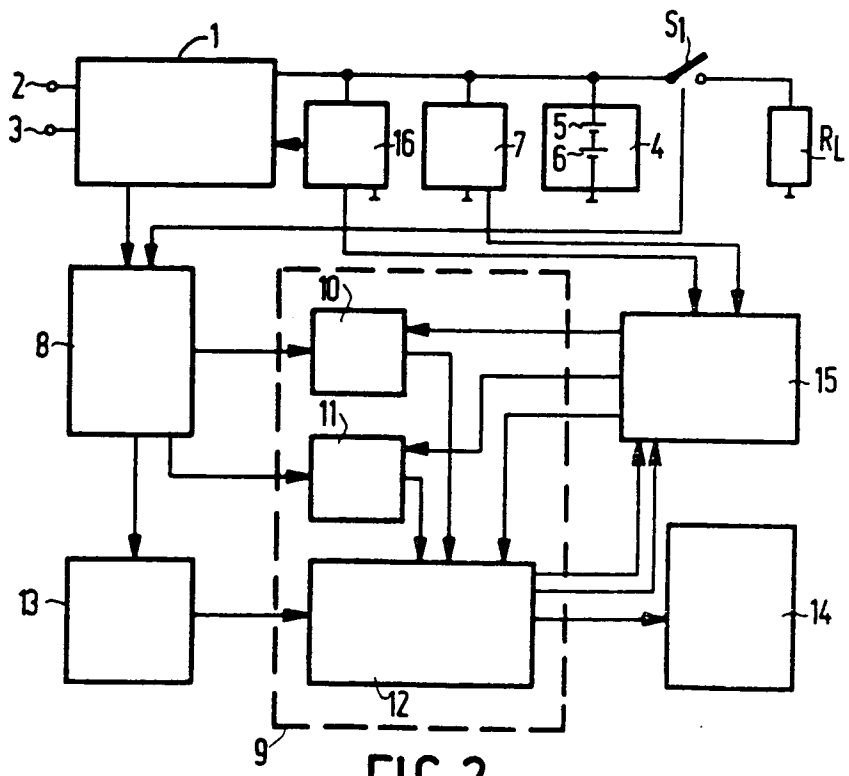

FIG. 2

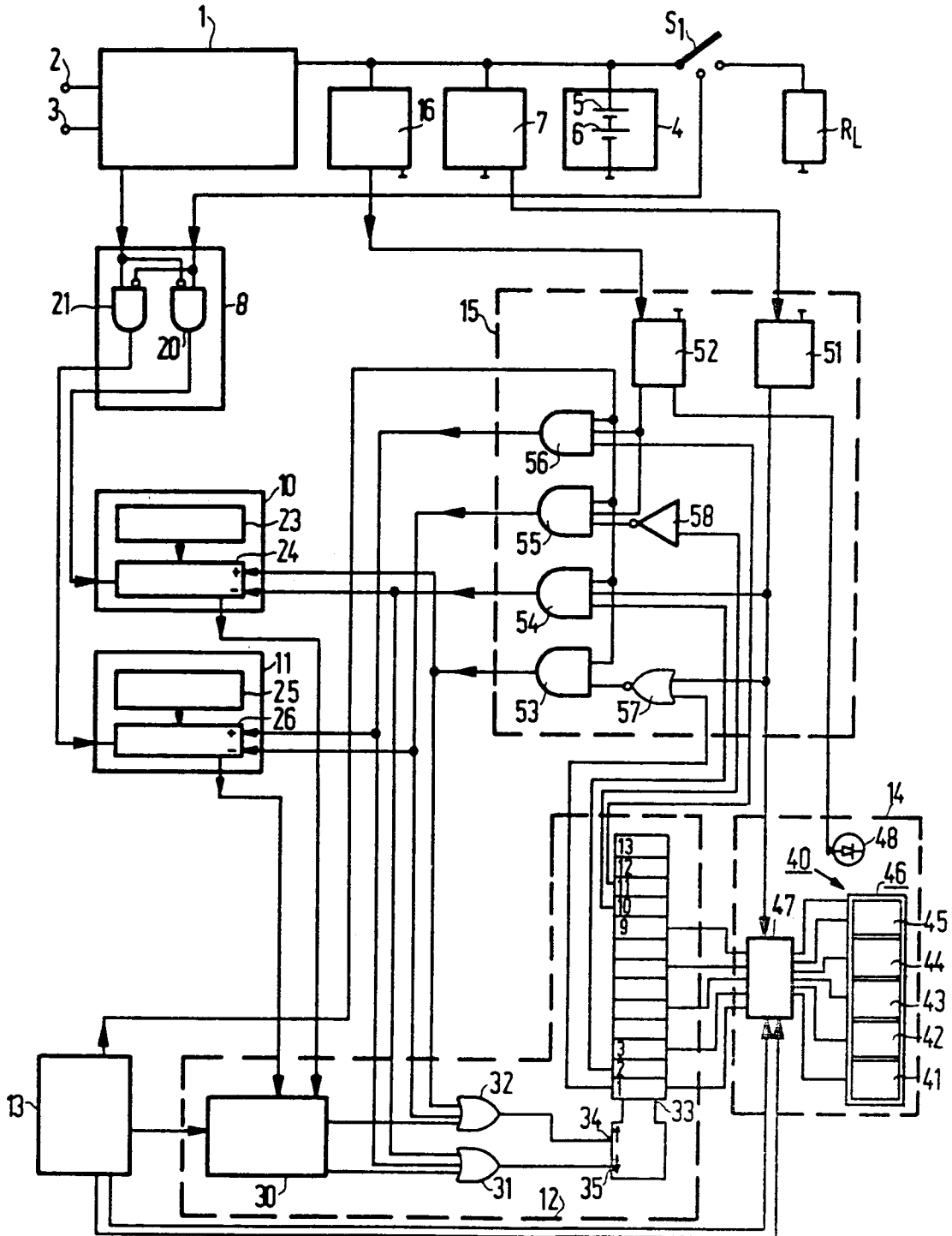

FIG. 3

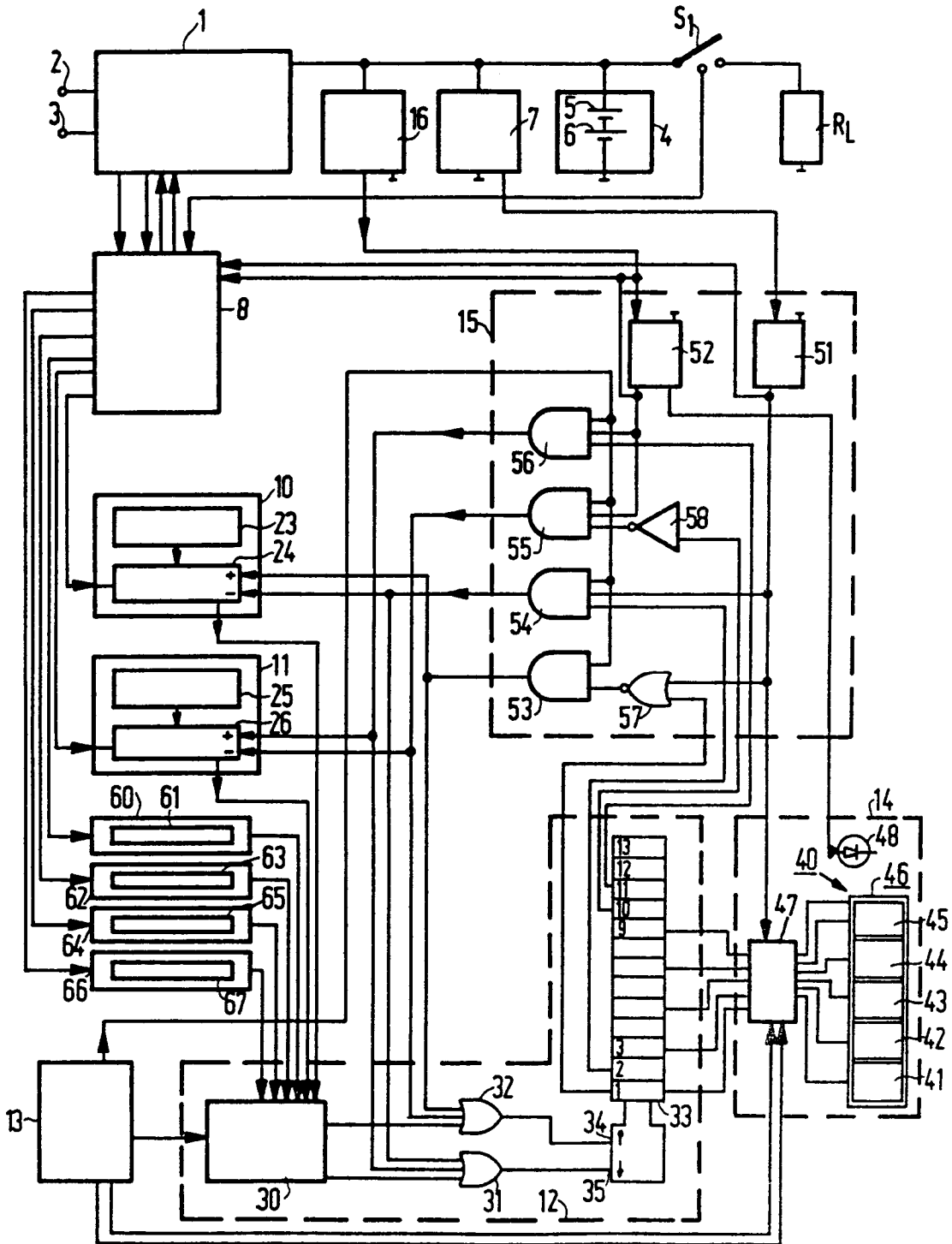

FIG. 4

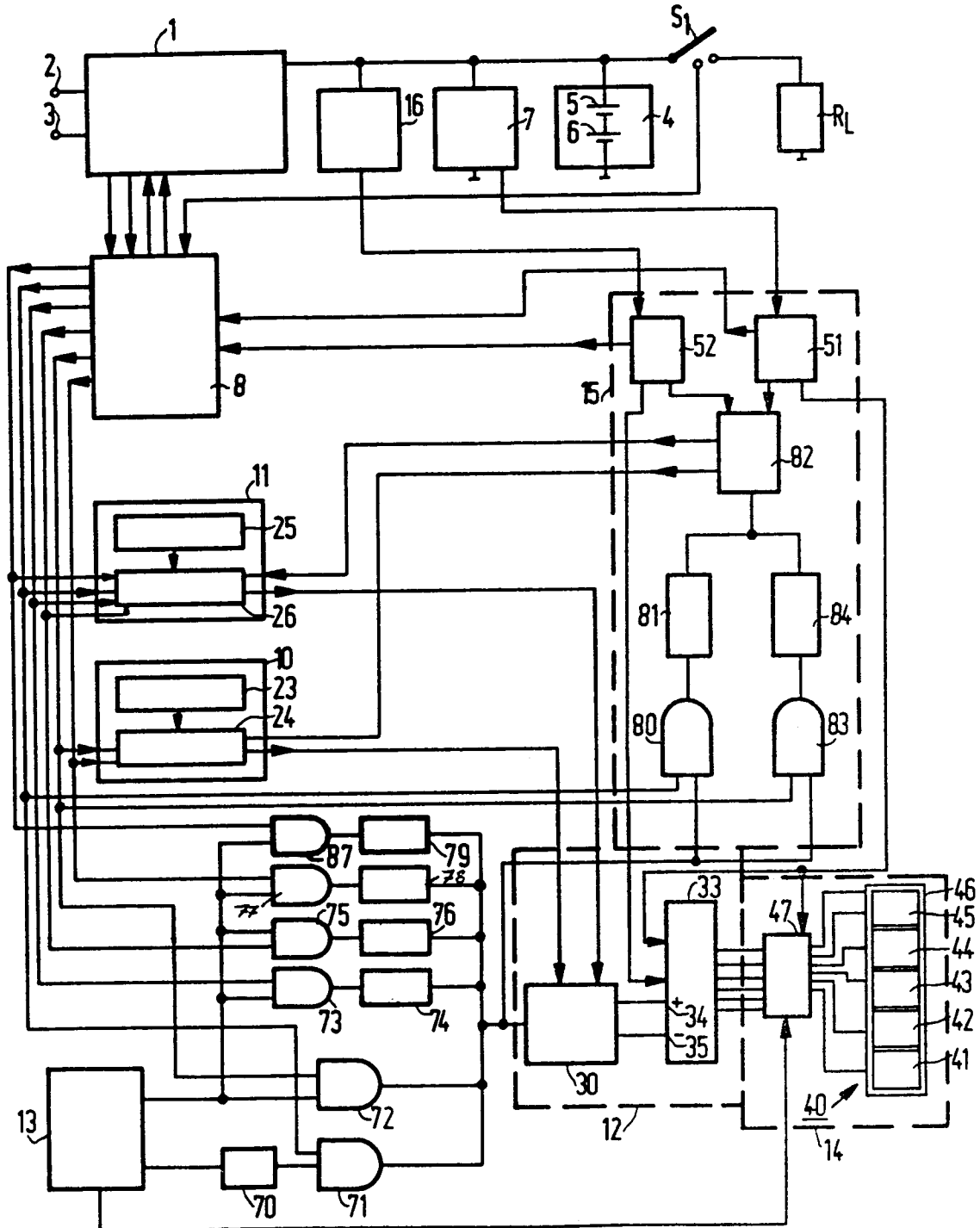

FIG. 5

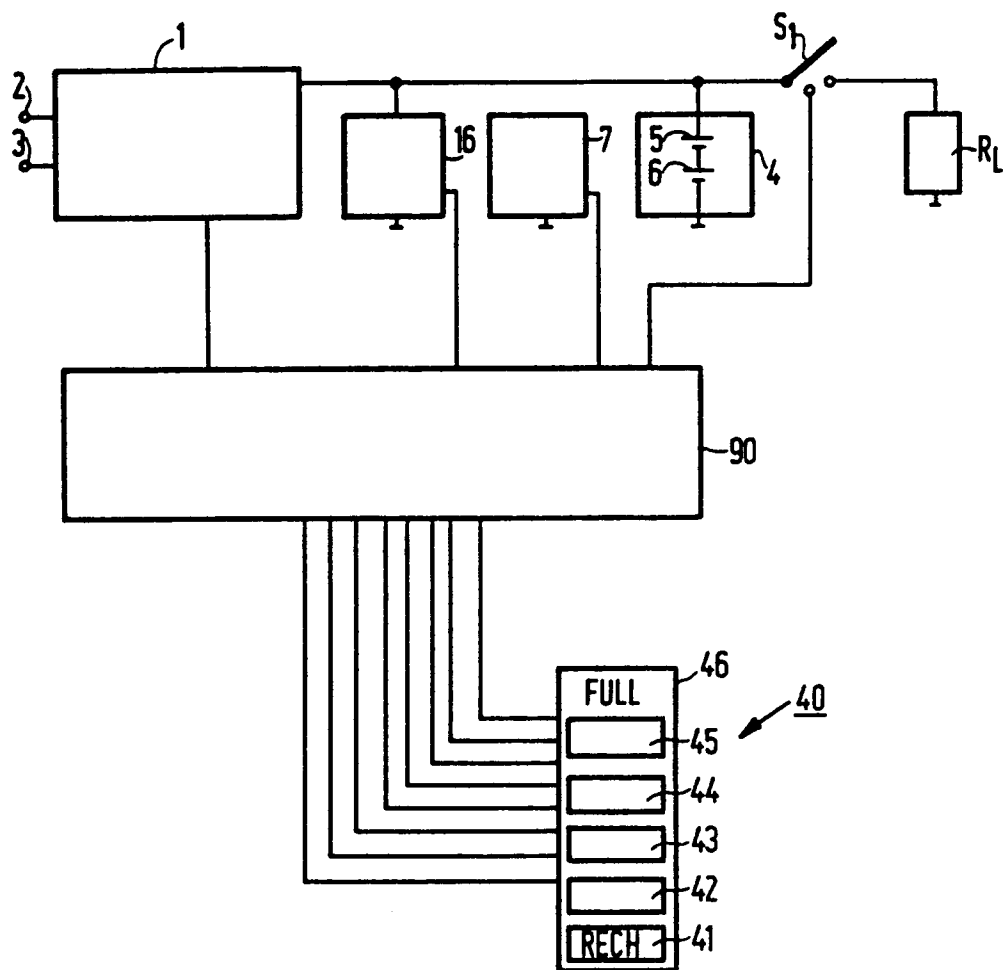

FIG. 6