

(19) World Intellectual Property Organization
International Bureau



(43) International Publication Date
17 March 2005 (17.03.2005)

PCT

(10) International Publication Number
WO 2005/025047 A1

(51) International Patent Classification⁷: H02P 6/00, 5/41

(74) Agents: FUKAMI, Hisao et al.; Fukami Patent Office, Mitsui Sumitomo Bank Minamimorimachi Bldg., 1-29, Minamimorimachi 2-chome, Kita-ku, Osaka-shi, Osaka 5300054 (JP).

(21) International Application Number:
PCT/JP2004/010091

(22) International Filing Date: 8 July 2004 (08.07.2004)

(81) Designated States (unless otherwise indicated, for every kind of national protection available): AE, AG, AL, AM, AT, AU, AZ, BA, BB, BG, BR, BW, BY, BZ, CA, CH, CN, CO, CR, CU, CZ, DE, DK, DM, DZ, EC, EE, EG, ES, FI, GB, GD, GE, GH, GM, HR, HU, ID, IL, IN, IS, KE, KG, KP, KR, KZ, LC, LK, LR, LS, LT, LU, LV, MA, MD, MG, MK, MN, MW, MX, MZ, NA, NI, NO, NZ, OM, PG, PH, PL, PT, RO, RU, SC, SD, SE, SG, SK, SL, SY, TJ, TM, TN, TR, TT, TZ, UA, UG, US, UZ, VC, VN, YU, ZA, ZM, ZW.

(25) Filing Language: English

(26) Publication Language: English

(30) Priority Data:
2003-204733 31 July 2003 (31.07.2003) JP

(71) Applicant (for all designated States except US): TOYOTA JIDOSHA KABUSHIKI KAISHA [JP/JP]; 1, Toyota-cho, Toyota-shi, Aichi 4718571 (JP).

(84) Designated States (unless otherwise indicated, for every kind of regional protection available): ARIPO (BW, GH, GM, KE, LS, MW, MZ, NA, SD, SL, SZ, TZ, UG, ZM, ZW), Eurasian (AM, AZ, BY, KG, KZ, MD, RU, TJ, TM), European (AT, BE, BG, CH, CY, CZ, DE, DK, EE, ES, FI, FR, GB, GR, HU, IE, IT, LU, MC, NL, PL, PT, RO, SE, SI, SK, TR), OAPI (BF, BJ, CF, CG, CI, CM, GA, GN, GQ, GW, ML, MR, NE, SN, TD, TG).

(72) Inventors; and
(75) Inventors/Applicants (for US only): OKAMURA, Masaki [JP/JP]; c/o Toyota Jidosha Kabushiki Kaisha, 1, Toyota-cho, Toyota-shi, Aichi 4718571 (JP). YAMASHITA, Takashi [JP/JP]; c/o Denso Corporation, 1-1, Showa-cho, Kariya-shi, Aichi 4488661 (JP).

[Continued on next page]

(54) Title: MOTOR DRIVE APPARATUS CAPABLE OF ACCURATELY ESTIMATING DEMAGNETIZATION OF PERMANENT MAGNET MOTOR

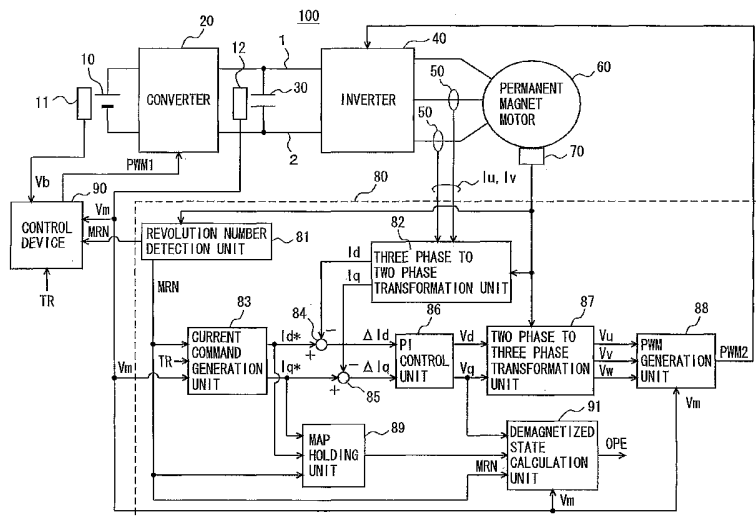

(57) Abstract: A map holding unit (89) holds, in the form of a map, a voltage control amount (Vq_map) of the q axis in a case where no demagnetization of a permanent magnet motor (60) occurs. Based on a motor revolution number, namely the number of revolutions of the motor (MRN) provided from a revolution number detection unit (81), a demagnetized state calculation unit (91) calculates a rotational angular velocity (ω). Then, based on the voltage control amount (Vq_map) from the map holding unit (89), a voltage control amount (Vq) to be controlled that is provided from a PI control unit (86) and the rotational angular velocity (ω), the demagnetized state calculation unit (91) calculates an amount of demagnetization (P(Vq_map - Vq) / ω) and outputs, if the amount of demagnetization is greater than a predetermined value, an operation signal (OPE) for controlling the operation of the permanent magnet motor (60).

WO 2005/025047 A1



Published:

— *with international search report*

For two-letter codes and other abbreviations, refer to the "Guidance Notes on Codes and Abbreviations" appearing at the beginning of each regular issue of the PCT Gazette.

DESCRIPTION

Motor Drive Apparatus Capable of Accurately Estimating
Demagnetization of Permanent Magnet Motor

5

Technical Field

The present invention relates to a motor drive apparatus capable of estimating demagnetization of a permanent magnet motor.

Background Art

10

Hybrid vehicles have recently been of great interest as environment-friendly vehicles. The hybrid vehicles are now partially commercialized.

15

A hybrid vehicle has, as its motive power sources, a DC (direct current) power supply, an inverter and a motor driven by the inverter in addition to a conventional engine. More specifically, the engine is driven to secure the motive power source and a DC voltage from the DC power supply is converted by the inverter into an AC voltage to be used for rotating the motor and thereby securing the motive power source as well.

20

Japanese Patent Laying-Open No. 2001-157304 discloses a motor drive system for a hybrid vehicle. The motor drive system estimates demagnetization of a permanent magnet of an electric rotating machine from the temperature of the permanent magnet according to data used for controlling the hybrid vehicle.

25

The conventional method, however, estimates demagnetization from the temperature of the permanent magnet which is estimated according to the control data for the hybrid vehicle, resulting in a problem that the demagnetization cannot accurately be estimated.

Disclosure of the Invention

An object of the present invention is thus to provide a motor drive apparatus cable of accurately estimating demagnetization of a permanent magnet motor.

According to the present invention, the motor drive apparatus includes an

estimation unit and an operation handling unit. The estimation unit estimates an amount of demagnetization of a permanent magnet motor based on a voltage control amount of the q axis applied in a case where the permanent magnet motor is controlled using a d-q axis transformation. The operation handling unit limits operation of the permanent magnet motor when the amount of demagnetization estimated by the estimation unit is greater than a predetermined value.

Preferably, the motor drive apparatus further includes a converter. The converter changes an input voltage necessary for driving the permanent magnet motor. The estimation unit corrects the estimated amount of demagnetization according to the level of the input voltage.

Preferably, the estimation unit estimates the amount of demagnetization by comparing the voltage control amount of the q axis to be controlled with a reference value.

Preferably, the estimation unit estimates the amount of demagnetization based on a difference between a reference value and the voltage control amount of the q axis to be controlled.

Preferably, the estimation unit holds, in the form of a map, the reference values correlated with at least two revolution numbers to extract the reference value and estimate the amount of demagnetization.

Preferably, the reference value is the voltage control amount of the q axis when no demagnetization of the permanent magnet motor occurs.

With the motor drive apparatus of the present invention, the amount of demagnetization is estimated based on the voltage control amount of the q axis applied when the permanent magnet motor is controlled using the d-q axis transformation, namely the armature flux linkage in the direction of the q axis among armature flux linkages emitted from permanent magnets. Then, if the estimated amount of demagnetization is larger than a predetermined value, the operation of the permanent magnet motor is limited.

The present invention can in this way estimate the amount of demagnetization accurately and, based on the estimated amount of demagnetization, the permanent magnet motor can appropriately be handled.

Brief Description of the Drawings

5 Fig. 1 is a schematic block diagram of a motor drive apparatus according to an embodiment of the present invention.

Fig. 2 is a circuit diagram of a converter shown in Fig. 1.

Fig. 3 is a circuit diagram of an inverter shown in Fig. 1.

10 Figs. 4A and 4B conceptually illustrate how to calculate an amount of demagnetization of a permanent magnet motor shown in Fig. 1.

Fig. 5 conceptually shows a map held by a map holding unit shown in Fig. 1.

Fig. 6 is a timing chart of voltage commands of the converter shown in Fig. 1.

Best Modes for Carrying Out the Invention

15 Embodiments of the present invention are hereinafter described in detail with reference to the drawings. It is noted here that like components are denoted by like reference characters and the description thereof is not repeated.

20 Referring to Fig. 1, according to an embodiment of the present invention, a motor drive apparatus 100 includes a DC power supply 10, voltage sensors 11 and 12, a converter 20, a capacitor 30, an inverter 40, electric-current sensors 50, a rotational position sensor 70, and control devices 80 and 90.

Converter 20 is connected between DC power supply 10 and capacitor 30.

Capacitor 30 is connected between a power supply line 1 and a ground line 2.

25 Voltage sensor 11 detects a DC voltage V_b which is output from DC power supply 10 to output the detected voltage to control device 90. Voltage sensor 12 detects a terminal-to-terminal voltage V_m of capacitor 30 to output the detected voltage V_m to control devices 80 and 90.

Converter 20 increases DC voltage V_b from DC power supply 10 in response to signal PWM1 from control device 90 to apply the increased voltage to capacitor 30.

Capacitor 30 then smoothes the DC voltage from converter 20 to apply the smoothed DC voltage to inverter 40.

Inverter 40 receives the DC voltage via capacitor 30 to convert the DC voltage into an AC voltage in response to signal PWM2 from control device 80 and thereby
5 drive a permanent magnet motor 60.

Electric-current sensors 50 detect motor currents I_u and I_v flowing through permanent magnet motor 60 to output the detected motor currents I_u and I_v to control device 80. In Fig. 1, there are provided only two current sensors 50 for the following reason. It is supposed here that permanent magnet motor 60 is a three-phase motor.
10 Then, motor currents I_u and I_v flowing through two phases respectively may be detected to calculate, from the detected motor currents I_u and I_v , motor current I_w flowing through the remaining phase. Therefore, if these motor currents I_u , I_v and I_w flowing through respective three phases are to be detected separately, three current sensors 50 may be provided.

15 Permanent magnet motor 60 which is the three-phase motor includes U, V and W-phase coils as stator coils.

Rotational position sensor 70 detects a rotational position of a rotor of permanent magnet motor 60 to output a sensor value θ indicative of the detected rotational position to control device 80.

20 Control device 80 includes a revolution number detection unit 81, a three-phase to two-phase transformation unit 82, a current command generation unit 83, subtracters 84 and 85, a PI control unit 86, a two-phase to three-phase transformation unit 87, a PWM generation unit 88, a map holding unit 89, and a demagnetized state calculation unit 91.

25 Revolution number detection unit 81 receives sensor value θ from rotational position sensor 70 to detect a motor revolution number MRN (number of revolutions of the motor) based on the received sensor value θ . Revolution number detection unit 81 then outputs this motor revolution number MRN to current command generation unit 83,

map holding unit 89, demagnetized state calculation unit 91 and control device 90.

Three-phase to two-phase transformation unit 82 receives respective motor currents I_u and I_v from two current sensors 50, 50. Based on motor currents I_u and I_v , three-phase to two-phase transformation unit 82 calculates motor current $I_w (= -I_u - I_v)$.

Then, three-phase to two-phase transformation unit 82 performs three-phase to two-phase transformation on motor currents I_u , I_v and I_w using sensor value θ from rotational position sensor 70. Specifically, three-phase to two-phase transformation unit 82 substitutes motor currents I_u , I_v and I_w and sensor value θ into the following expression to calculate current values I_d and I_q .

$$\begin{bmatrix} I_d \\ I_q \end{bmatrix} = \frac{2}{3} \begin{bmatrix} -\cos \theta & -\cos(\theta - \frac{2}{3}\pi) & -\cos(\theta + \frac{2}{3}\pi) \\ \sin \theta & \sin(\theta - \frac{2}{3}\pi) & \sin(\theta + \frac{2}{3}\pi) \end{bmatrix} \begin{bmatrix} I_u \\ I_v \\ I_w \end{bmatrix} \dots (1)$$

More specifically, using sensor value θ , three-phase to two-phase transformation unit 82 transforms respective three-phase motor currents I_u , I_v and I_w flowing through respective three-phase coils of permanent magnet motor 60 into current values I_d and I_q . Three-phase to two-phase transformation unit 82 then outputs the calculated current values I_d and I_q to subtractors 84 and 85 respectively.

Current command generation unit 83 receives a torque command value T_R from an ECU (Electrical Control Unit) provided outside motor drive apparatus 100, receives motor revolution number MRN from revolution number detection unit 81 and receives voltage V_m from voltage sensor 12. Then, current command generation unit 83 generates, based on these torque command value T_R , motor revolution number MRN and voltage V_m , current commands I_d^* and I_q^* for outputting the torque indicated by torque command value T_R , outputs the generated current command I_d^* to subtractor 84 and map holding unit 89 and outputs the generated current command I_q^* to subtractor 85 and map holding unit 89.

Subtractor 84 calculates deviation ΔId between current command Id^* and current value Id to output the calculated deviation ΔId to PI control unit 86.

Subtractor 85 calculates deviation ΔIq between current command Iq^* and current value Iq to output the calculated deviation ΔIq to PI control unit 86.

5 PI control unit 86 uses a PI gain for deviations ΔId and ΔIq to calculate voltage control amounts Vd and Vq for adjusting the motor current, outputs the calculated voltage control amount Vd to two-phase to three-phase transformation unit 87 and outputs the calculated voltage control amount Vq to two-phase to three-phase transformation unit 87 and demagnetized state calculation unit 91.

10 Two-phase to three-phase transformation unit 87 performs two-phase to three-phase transformation on voltage control amounts Vd and Vq from PI control unit 86 using sensor value θ from rotational position sensor 70. Specifically, two-phase to three-phase transformation unit 87 substitutes voltage control amounts Vd and Vq from PI control unit 86 and sensor value θ from rotational position sensor 70 into the
 15 following expression to calculate voltage control amounts Vu , Vv and Vw to be applied to the three-phase coils of permanent magnet motor 60.

$$\begin{bmatrix} Vu \\ Vv \\ Vw \end{bmatrix} = \begin{bmatrix} -\cos\theta & \sin\theta \\ -\cos(\theta - \frac{2}{3}\pi) & \sin(\theta - \frac{2}{3}\pi) \\ -\cos(\theta + \frac{2}{3}\pi) & \sin(\theta + \frac{2}{3}\pi) \end{bmatrix} \begin{bmatrix} Vd \\ Vq \end{bmatrix} \dots (2)$$

In other words, using sensor value θ , two-phase to three-phase transformation unit 87 transforms voltage control amounts Vd and Vq applied to the d axis and the q axis into voltage control amounts Vu , Vv and Vw applied to the three-phase coils of permanent magnet motor 60.
 20

Then, two-phase to three-phase transformation unit 87 outputs voltage control amounts Vu , Vv and Vw to PWM generation unit 88.

PWM generation unit 88 generates signal PWM2 based on voltage control

amounts V_u , V_v and V_w and voltage V_m from voltage sensor 12 to output the generated signal PWM2 to inverter 40. More specifically, PWM generation unit 88 sets the amplitude and width of a pulse according to the level of voltage V_m to generate signal PWM2. Here, if the level of voltage V_m is relatively higher, PWM generation
5 unit 88 makes the amplitude of the pulse relatively higher while making the width thereof relatively smaller to generate signal PWM2.

Map holding unit 89 holds a map showing a voltage control amount V_{q_map} of the q axis measured for each pair of current commands I_d^* and I_q^* , and the control amount is correlated with at least two motor revolution numbers. This voltage control
10 amount V_{q_map} is a voltage control amount of the q axis in a case where permanent magnet motor 60 is not demagnetized.

Map holding unit 89 receives current commands I_d^* and I_q^* from current command generation unit 83 and receives motor revolution number MRN from revolution number detection unit 81 to extract voltage control amount V_{q_map}
15 correlated with these motor revolution number MRN and current commands I_d^* and I_q^* and output the extracted control amount to demagnetized state calculation unit 91.

Demagnetized state calculation unit 91 calculates, according to a method hereinafter described, an amount of demagnetization of permanent magnet motor 60 based on voltage control amount V_q of the q axis from PI control unit 86, voltage
20 control amount V_{q_map} from map holding unit 89 and motor revolution number MRN from revolution number detection unit 81, and limits the current to be flown to permanent magnet motor 60 or motor revolution number MRN of permanent magnet motor 60 or outputs operation signal OPE for outputting a warning to the outside if the calculated amount of demagnetization is greater than a predetermined value.

Moreover, demagnetized state calculation unit 91 corrects, with a method hereinafter described, the calculated amount of demagnetization according to the level of
25 voltage V_m from voltage sensor 12.

Control device 90 generates signal PWM1 for controlling converter 20 based on

torque command value TR from the external ECU, DC voltage Vb from voltage sensor 11, voltage Vm from voltage sensor 12 and motor revolution number MRN from revolution number detection unit 81, and outputs the generated signal PWM1 to converter 20.

5 More specifically, control device 90 calculates a voltage command for converter 20 based on torque command value TR and motor revolution number MRN to generate, based on the calculated voltage command, DC voltage Vb and voltage Vm, signal PWM1 for setting voltage Vm to the voltage command.

10 Fig. 2 is a circuit diagram of converter 20 shown in Fig. 1. Referring to Fig. 2, converter 20 includes NPN transistors Q1 and Q2, diodes D1 and D2 and a reactor L1. NPN transistors Q1 and Q2 are connected in series between power-supply line 1 and ground line 2. Reactor L1 has one end connected to the intermediate point between NPN transistor Q1 and NPN transistor Q2 and the other end connected to the positive electrode of DC power supply 10. Between respective collectors and emitters of NPN transistors Q1 and Q2, diodes D1 and D2 for allowing current to flow from the emitter to the collector of the transistors each are connected respectively.

15 Fig. 3 is a circuit diagram of inverter 40 shown in Fig. 1. Referring to Fig. 3, inverter 40 includes a U phase arm 15, a V phase arm 16 and a W phase arm 17. U phase arm 15, V phase arm 16 and W phase arm 17 are provided in parallel between power-supply line 1 and ground line 2.

20 U phase arm 15 is comprised of NPN transistors Q3 and Q4 connected in series, V phase arm 16 is comprised of NPN transistors Q5 and Q6 connected in series, and W phase arm 17 is comprised of NPN transistors Q7 and Q8 connected in series. Between respective collectors and emitters of NPN transistors Q3-Q8, diodes D3-D8 for allowing current to flow from the emitter to the collector of NPN transistors Q3-Q8 each are connected respectively.

The intermediate point of the phase arms each of inverter 40 is connected to an end of the phase coils each of permanent magnet motor 60. In other words, the end of

the U phase coil of permanent magnet motor 60 is connected to the intermediate point between NPN transistors Q3 and Q4, the end of the V phase coil thereof is connected to the intermediate point between NPN transistors Q5 and Q6 and the end of the W phase coil thereof is connected to the intermediate point between NPN transistors Q7 and Q8.

5 Figs. 4A and 4B conceptually illustrate how to calculate an amount of demagnetization of permanent magnet motor 60 shown in Fig. 1. The voltage generated by magnets of permanent magnet motor 60 appears in the direction of the q axis.

Thus, according to the present invention, the amount of demagnetization of permanent magnet motor 60 is calculated based on voltage control amount V_q of the q axis that is applied when permanent magnet motor 60 is controlled using the d-q axis transformation.

In the case where permanent magnet motor 60 is controlled with the d-q axis transformation, the voltage of the q axis is represented by the following voltage equation:

$$V_q = \omega\Phi - \omega L_d I_d + R I_q \dots (3)$$

where ω is rotational angular velocity, Φ is armature flux linkage by permanent magnets, L_d is inductance of the q axis, R is armature resistance, I_d is d axis component of armature current and I_q is q axis component of the armature current.

20 In equation (3), the term $\omega L_d I_d$ is used for field-weakening control.

Fig. 4A shows a case where no demagnetization occurs while Fig. 4B shows a case where demagnetization occurs. If demagnetization does not occur, the armature flux linkage is Φ_c and the voltage control amount of the q axis is V_{qc} . Then, in the case where no demagnetization occurs, the following expression is established.

$$25 \quad V_{qc} = \omega\Phi_c - \omega L_d I_d + R I_q \dots (4)$$

If demagnetization occurs, the armature flux linkage is Φ_1 and the voltage control amount of the q axis is V_{q1} . Then, in the case where demagnetization occurs, the following expression is established.

$$V_{q1} = \omega \Phi_1 - \omega L_d I_d + R I_q \dots (5)$$

Expression (5) is then subtracted from expression (4):

$$V_{qc} - V_{q1} = \omega (\Phi_c - \Phi_1)$$

$$\Phi_c - \Phi_1 = (V_{qc} - V_{q1}) / \omega \dots (6).$$

5 There is a relation $\Phi_1 < \Phi_c$ in the case where demagnetization occurs so that the left side of expression (6) represents an amount of change in armature flux linkage, namely an amount of demagnetization.

 Therefore, the right side of expression (6) can be calculated to determine the amount of demagnetization.

10 According to the present invention, voltage control amount V_{qc} of the q axis in the case where no demagnetization occurs is measured in advance for each pair of current commands I_d^* and I_q^* and the resultant value V_{q_map} is held in the form of the map. Then, the measured value V_{q_map} , voltage control amount V_{q1} to be controlled and rotational angular velocity ω are substituted into expression (6) to determine the
15 amount of demagnetization $\Phi_c - \Phi_1$.

 If the determined amount of demagnetization $\Phi_c - \Phi_1$ is a positive value, demagnetization of permanent magnet motor 60 occurs. If the determined amount of demagnetization $\Phi_c - \Phi_1$ is zero, no demagnetization of permanent magnet motor 60 occurs.

20 Thus, according to the present invention, the amount of demagnetization is calculated based on voltage control amount V_q of the q axis in controlling permanent magnet motor 60 through the d-q axis transformation. Then, from the calculated amount of demagnetization, it is determined whether or not demagnetization of
 permanent magnet motor 60 occurs.

25 Fig. 5 conceptually shows the map held by map holding unit 89 shown in Fig. 1. Referring to Fig. 5, this map MAP is comprised of a plurality of voltage control amounts V_{q_map} each located at a point of intersection between a line representing a motor revolution number and a line representing a torque. The white circles in Fig. 5 each

represent voltage control amount Vq_map .

This map MAP includes voltage control amounts Vq_map for at least two motor revolution numbers MRN1 and MRN 2.

5 Regarding permanent magnet motor 60, the torque is a function between the d axis component I_d and the q axis component I_q of the armature current, so that the torque shown in Fig. 5 represents the d axis component I_d and the q axis component I_q of the armature current. Therefore, the fact that voltage control amount Vq_map is located at the point of intersection between a line representing a motor revolution number and a line representing a torque means that voltage control amount Vq_map is located at the point of intersection between the line representing the motor revolution number and respective lines representing the d axis component I_d and the q axis component I_q of the armature current. In other words, map MAP is comprised of voltage control amounts Vq_map correlated with motor revolution numbers MRN1, MRN2 and the d axis component I_d and the q axis component I_q of the armature current.

15 Referring again to Fig. 1, map holding unit 89 receives current commands I_d^* and I_q^* from current command generation unit 83 and receives motor revolution number MRN from revolution number detection unit 81. As discussed above, map MAP is comprised of voltage control amounts Vq_map correlated with motor revolution numbers MRN1 and MRN2 and d axis and q axis components I_d and I_q of the armature current. Then, map holding unit 89 extracts from map MAP voltage control amount Vq_map located at the point correlated with current commands I_d^* and I_q^* from current command generation unit 83 and motor revolution number MRN from revolution number detection unit 81 to output the extracted voltage control amount Vq_map to demagnetized state calculation unit 91.

20 Demagnetized state calculation unit 91 receives voltage control amount Vq from PI control unit 86, receives voltage control amount Vq_map from map holding unit 89 and receives motor revolution number MRN from revolution number detection unit 81.

Then, demagnetized state calculation unit 91 calculates rotational angular velocity ω based on motor revolution number MRN from revolution number detection unit 81 and substitutes the calculated rotational angular velocity ω and voltage control amounts V_{q_map} and V_q into expression (6). In this case, voltage control amount V_{q_map} is substituted for V_{qc} of expression (6) and voltage control amount V_q is substituted for V_{q1} of expression (6).

If the result of calculation $\Phi_c - \Phi_1$ is larger than a predetermined value, demagnetized state calculation unit 91 determines that demagnetization of permanent magnet motor 60 occurs to generate operation signal OPE and output this signal to the external ECU. In contrast, if the result of calculation $\Phi_c - \Phi_1$ is equal to or smaller than the predetermined value, demagnetized state calculation unit 91 determines that no demagnetization of permanent magnet motor 60 occurs.

In this way, demagnetized state calculation unit 91 calculates an amount of change in armature flux linkage based on voltage control amount V_{q_map} which is measured in advance when no demagnetization of permanent magnet motor 60 occurs as well as voltage control amount V_q to be controlled and determines, from the result of the calculation, whether or not demagnetization of permanent magnet motor 60 occurs.

If demagnetization of permanent magnet motor 60 occurs, sensor value θ from rotational position sensor 70 reflects the demagnetization and accordingly, three-phase to two-phase transformation unit 82 transforms motor currents I_u , I_v and I_w into current values I_d and I_q with sensor value θ reflecting the demagnetization. Current values I_d and I_q are thus influenced by demagnetization.

PI control unit 86 then uses a PI gain for deviations $\Delta I_d (= I_d^* - I_d)$ and $\Delta I_q (= I_q^* - I_q)$ to calculate voltage control amounts V_d and V_q for adjusting the motor current, so that voltage control amount V_q is a value reflecting demagnetization.

Accordingly, with the result of calculation $\Phi_c - \Phi_1$ performed through substitution of voltage control amounts V_{q_map} and V_q into expression (6), whether or not demagnetization of permanent magnet motor 60 occurs can be determined.

Demagnetized state calculation unit 91 corrects, according to the input voltage of inverter 40, namely the level of output voltage V_m of converter 20, the amount of demagnetization $\Phi_c - \Phi_1$ which is calculated by the above-described method.

Fig. 6 is a timing chart of voltage commands of converter 20 shown in Fig. 1.

5 It is herein described above that voltage control amount V_{q_map} in the case where no demagnetization of permanent magnet motor 60 occurs is measured in advance. The measured voltage control amount V_{q_map} includes the dead time of NPN transistors Q3-Q8 that are components of inverter 40.

Referring to Fig. 6, when the DC voltage applied to inverter 40 is 500 V, the
10 voltage command of the q axis, namely voltage control amount V_{q_map} , is represented by signal PL1. Signal PL1 is a pulse signal with width W_1 and height H_1 . This signal PL1 includes dead time D_1 . Dead time D_1 has the same height H_1 as that of signal PL1 and width w .

When the DC voltage applied to inverter 40 decreases to 250 V, the voltage
15 command of the q axis, namely voltage control amount V_{q_map} , is represented by signal PL2. Signal PL2 is a pulse signal with width W_2 and height H_2 . Since the DC voltage applied to inverter 40 decreases from 500 V to 250 V, the width and height are those values represented respectively by width $W_2 = 2 \times W_1$ and height $H_2 = (H_1) / 2$.

Then, the dead time which should essentially be included in signal PL2 is dead
20 time D_2 having height H_2 and width w . However, with voltage control amount V_{q_map} being measured at the DC voltage of 500 V, signal PL2 has the same dead time D_1 as that of signal PL1 if no dead time correction is made for addressing the decrease in DC voltage applied to inverter 40. In other words, signal PL2 includes an extra dead time D_3 in addition to dead time D_2 which should essentially be included.

25 Accordingly, if the DC voltage applied to inverter 40 decreases, voltage control amount V_{q_map} has to be corrected by removing the extra dead time D_3 . Moreover, if the DC voltage applied to inverter 40 increases, voltage control amount V_{q_map} has to be corrected by adding the shortage dead time.

Then, demagnetized state calculation unit 91 corrects voltage control amount V_{q_map} from map holding unit 89 by expressions (7) and (8) according to the level of voltage V_m from voltage sensor 12.

$$V_{q_map_ad} = V_{q_map} \pm V_{dead_q} \dots (7)$$

$$5 \quad V_{dead_q} = (V_{mi} - V_{mf}) * (D_i) * (f_c) * \cos\beta * (3)^{1/2} \dots (8)$$

where V_{mi} is input voltage to inverter 40 in measuring voltage control amount V_{q_map} , V_{mf} is input voltage to inverter 40 under control, D_i is dead time in measuring voltage control amount V_{q_map} , f_c is switching frequency of inverter 40, and β is angle formed by the q axis and a current vector.

10 In expression (7), the sign "-" in the sign " \pm " indicates a decrease in DC voltage which is input to inverter 40 and the sign "+" therein indicates an increase in DC voltage input to inverter 40.

Demagnetized state calculation unit 91 then substitutes the corrected voltage control amount $V_{q_map_ad}$, voltage control amount V_q to be controlled and rotational angular velocity ω into expression (6) to calculate the amount of demagnetization $\Phi_c - \Phi_1$.

15 In this case, since the amount of demagnetization $\Phi_c - \Phi_1$ is calculated using the corrected voltage control amount $V_{q_map_ad}$, the calculation of the amount of demagnetization $\Phi_c - \Phi_1$ with the corrected voltage control amount $V_{q_map_ad}$ corresponds to correction of the amount of demagnetization $\Phi_c - \Phi_1$.

In other words, demagnetized state calculation unit 91 corrects the amount of demagnetization $\Phi_c - \Phi_1$ according to the level of the input voltage to inverter 40. It is noted that the correction of the dead time according to the input voltage can be made by providing V_{q_maps} correlated with respective voltages.

25 As motor drive apparatus 100 includes converter 20 as shown in Fig. 1, the level of voltage V_m applied to inverter 40 varies depending on the output torque of permanent magnet motor 60.

It is thus advantageous that the amount of demagnetization is corrected according to the level of the DC voltage applied to inverter 40 in terms of accurate determination of the amount of demagnetization for motor drive apparatus 100 having converter 20.

5 If the switching frequency of inverter 40 changes, the influence of the dead time accordingly changes. Therefore, according to the present invention, voltage control amount Vq_map may also be corrected if the switching frequency of inverter 40 under control changes from the switching frequency of inverter 40 at the time when voltage control amount Vq_map is measured.

10 As discussed above, demagnetized state calculation unit 91 calculates the difference between voltage control amount Vq_map of the q axis in the case where no magnetization of permanent magnet motor 60 occurs and voltage control amount Vq to be controlled that is calculated by PI control unit 86 to estimate the amount of demagnetization $\Phi_c - \Phi_1$. According to the present invention, voltage control amount
15 Vq to be controlled may be compared with voltage control amount Vq_map (corresponding to "reference value") to determine whether or not demagnetization of permanent magnet motor 60 occurs according to the result of the comparison.

In this case, demagnetized state calculation unit 91 determines that demagnetization of permanent magnet motor 60 occurs if voltage control amount Vq is
20 smaller than voltage control amount Vq_map and determines that no demagnetization of permanent magnet motor 60 occurs if voltage control amount Vq is equal to voltage control amount Vq_map .

Motor drive apparatus 100 described above is mounted on a hybrid vehicle. If demagnetization of permanent magnet motor 60 occurs, the external ECU instructs
25 control device 80 to stop permanent magnet motor 60 according to operation signal OPE from demagnetized state calculation unit 91 and accordingly performs control in such a manner that the vehicle runs with the engine. The hybrid vehicle can thus be run safely.

It is seen from the above that accurate estimation of the amount of demagnetization of permanent magnet motor 60 is particularly effective if motor drive apparatus 100 is mounted on a hybrid vehicle.

5 "Estimation means" for estimating the amount of demagnetization of permanent magnet motor 60 is comprised of map holding unit 89 and demagnetized state calculation unit 91.

"Operation handling means" for limiting the operation of permanent magnet motor 60 is implemented by a function of demagnetized state calculation unit 91 of outputting operation signal OPE if the calculated amount of demagnetization is larger than a
10 predetermined value, among several functions of demagnetized state calculation unit 91.

Moreover, while it is described above that voltage control amount Vq_map is extracted according to current commands Id^* and Iq^* , the present invention is not limited to this and voltage control amount Vq_map may be extracted according to currents Id and Iq detected by current sensors 50 and undergo transformation by three-
15 phase to two-phase transformation unit 82.

Although the present invention has been described and illustrated in detail, it is clearly understood that the same is by way of illustration and example only and is not to be taken by way of limitation, the spirit and scope of the present invention being limited only by the terms of the appended claims.

20 Industrial Applicability

The present invention is applied to a motor drive apparatus capable of accurately estimating demagnetization of a permanent magnet motor.

CLAIMS

1. A motor drive apparatus comprising:
estimation means (89, 91) estimating an amount of demagnetization of a
5 permanent magnet motor (60) based on a voltage control amount of the q axis applied in
a case where said permanent magnet motor (60) is controlled using a d-q axis
transformation; and
operation handling means (91) limiting operation of said permanent magnet
motor (60) when said estimated amount of demagnetization is larger than a
10 predetermined value.
2. The motor drive apparatus according to claim 1, further comprising a
converter (20) changing an input voltage necessary for driving said permanent magnet
motor (6), wherein
15 said estimation means (89, 91) corrects said estimated amount of
demagnetization according to the level of said input voltage.
3. The motor drive apparatus according to claim 1, wherein
said estimation means (89, 91) estimates said amount of demagnetization by
20 comparing the voltage control amount of the q axis to be controlled with a reference
value.
4. The motor drive apparatus according to claim 3, wherein
said estimation means (89, 91) holds, in the form of a map (MAP), the reference
25 values correlated with at least two revolution numbers to extract said reference value
from said map (MAP) and estimate said amount of demagnetization.
5. The motor drive apparatus according to claim 1, wherein

said estimation means (89, 91) estimates said amount of demagnetization based on a difference between a reference value and the voltage control amount of the q axis to be controlled.

5 6. The motor drive apparatus according to claim 5, wherein
said estimation means (89, 91) holds, in the form of a map (MAP), the reference values correlated with at least two revolution numbers to extract said reference value from said map (MAP) and estimate said amount of demagnetization.

10 7. The motor drive apparatus according to any of claims 3-6, wherein
said reference value is said voltage control amount of the q axis when no demagnetization of said permanent magnet motor (60) occurs.

FIG. 1

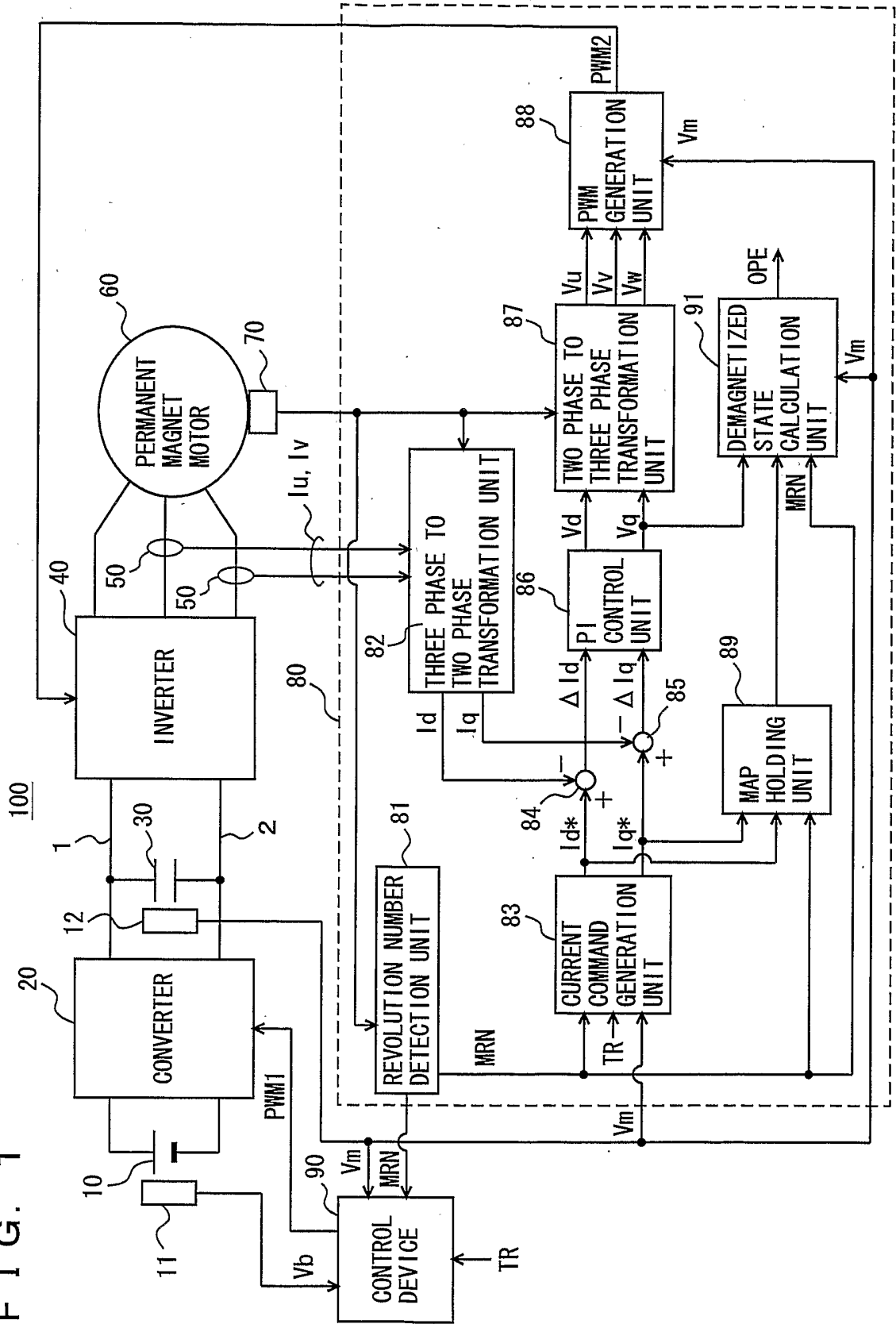

FIG. 2

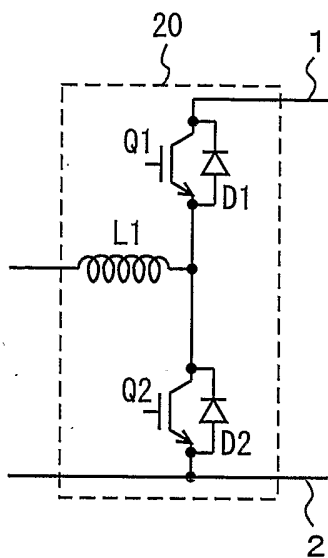

FIG. 3

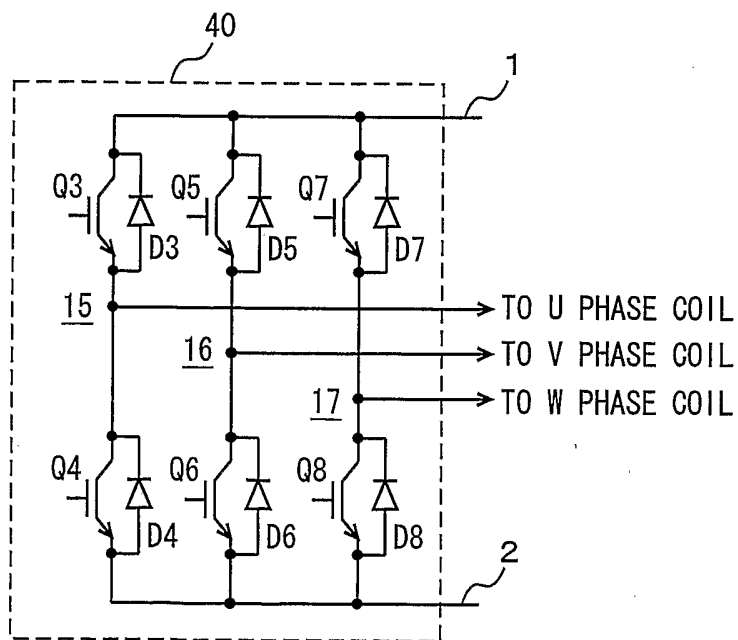

FIG. 4A

FIG. 4B

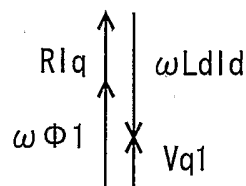
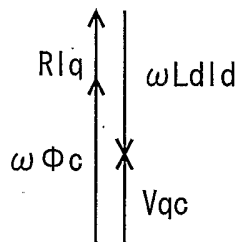
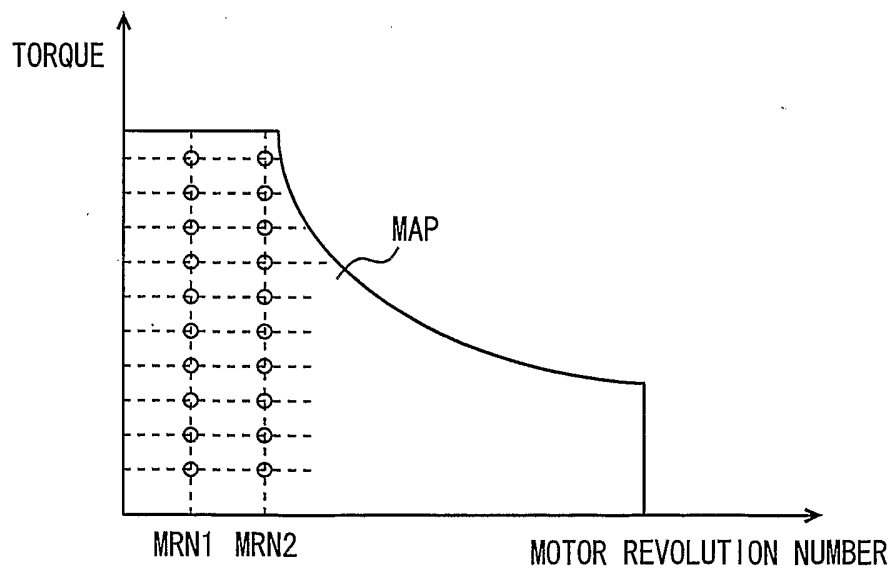
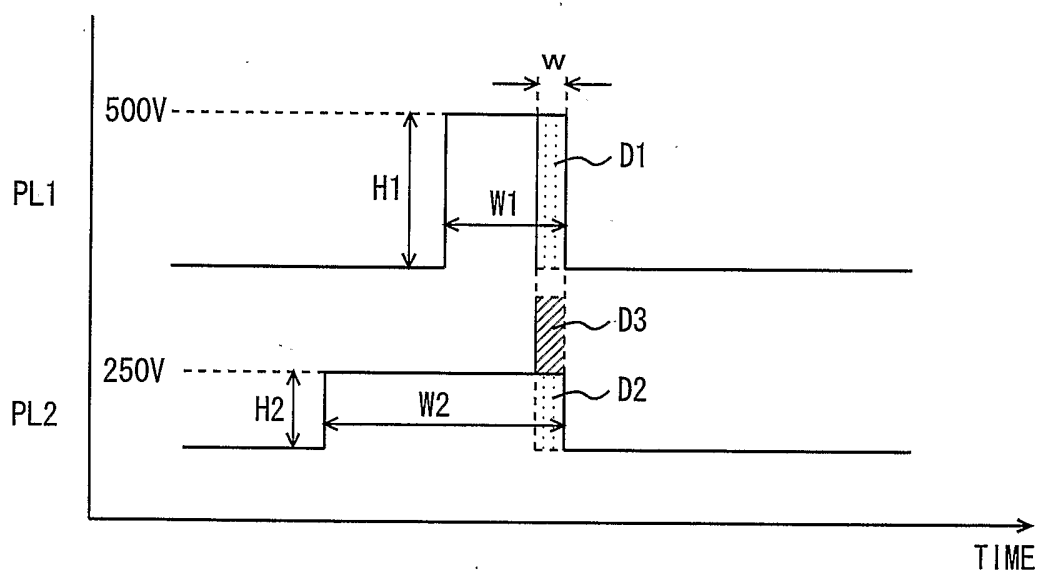

FIG. 5



F I G. 6



INTERNATIONAL SEARCH REPORT

International Application No
PCT/JP2004/010091

A. CLASSIFICATION OF SUBJECT MATTER
IPC 7 H02P6/00 H02P5/41

According to International Patent Classification (IPC) or to both national classification and IPC

B. FIELDS SEARCHED

Minimum documentation searched (classification system followed by classification symbols)
IPC 7 H02P B60L

Documentation searched other than minimum documentation to the extent that such documents are included in the fields searched

Electronic data base consulted during the international search (name of data base and, where practical, search terms used)

EPO-Internal, PAJ, WPI Data, INSPEC

C. DOCUMENTS CONSIDERED TO BE RELEVANT

Category °	Citation of document, with indication, where appropriate, of the relevant passages	Relevant to claim No.
X	US 5 650 706 A (KAWABATA YASUTOMO ET AL) 22 July 1997 (1997-07-22) abstract column 1, line 11 - line 38 column 2, line 43 - line 47 column 2, line 51 - line 55 column 4, line 7 - line 16 column 5, line 5 - line 43 column 6, line 16 - line 23 claim 4 figures 1-3	1
A	----- -/--	2-7

Further documents are listed in the continuation of box C.

Patent family members are listed in annex.

° Special categories of cited documents :

"A" document defining the general state of the art which is not considered to be of particular relevance
"E" earlier document but published on or after the international filing date
"L" document which may throw doubts on priority claim(s) or which is cited to establish the publication date of another citation or other special reason (as specified)
"O" document referring to an oral disclosure, use, exhibition or other means
"P" document published prior to the international filing date but later than the priority date claimed

"T" later document published after the international filing date or priority date and not in conflict with the application but cited to understand the principle or theory underlying the invention
"X" document of particular relevance; the claimed invention cannot be considered novel or cannot be considered to involve an inventive step when the document is taken alone
"Y" document of particular relevance; the claimed invention cannot be considered to involve an inventive step when the document is combined with one or more other such documents, such combination being obvious to a person skilled in the art.
"&" document member of the same patent family

Date of the actual completion of the international search

20 January 2005

Date of mailing of the international search report

27/01/2005

Name and mailing address of the ISA

European Patent Office, P.B. 5818 Patentlaan 2
NL - 2280 HV Rijswijk
Tel. (+31-70) 340-2040, Tx. 31 651 epo nl,
Fax: (+31-70) 340-3016

Authorized officer

Roider, A

INTERNATIONAL SEARCH REPORT

International Application No
PCT/JP2004/010091

C.(Continuation) DOCUMENTS CONSIDERED TO BE RELEVANT		
Category *	Citation of document, with indication, where appropriate, of the relevant passages	Relevant to claim No.
A	<p>PATENT ABSTRACTS OF JAPAN vol. 2000, no. 26, 1 July 2002 (2002-07-01) & JP 2001 268970 A (SANYO ELECTRIC CO LTD; KUMAGAYA SEIMITSU KK), 28 September 2001 (2001-09-28) abstract</p> <p>-----</p>	1
A	<p>PATENT ABSTRACTS OF JAPAN vol. 2003, no. 11, 5 November 2003 (2003-11-05) & JP 2003 204693 A (FORD GLOBAL TECHNOL INC), 18 July 2003 (2003-07-18) abstract</p> <p>-----</p>	1
A	<p>PATENT ABSTRACTS OF JAPAN vol. 0162, no. 27 (E-1207), 26 May 1992 (1992-05-26) & JP 04 042764 A (NIPPON CHEMICON CORP), 13 February 1992 (1992-02-13) abstract</p> <p>-----</p>	1
A	<p>PATENT ABSTRACTS OF JAPAN vol. 2000, no. 23, 10 February 2001 (2001-02-10) & JP 2001 157304 A (DENSO CORP), 8 June 2001 (2001-06-08) cited in the application abstract</p> <p>-----</p>	1

INTERNATIONAL SEARCH REPORT

Information on patent family members

International Application No

PCT/JP2004/010091

Patent document cited in search report		Publication date	Patent family member(s)	Publication date
US 5650706	A	22-07-1997	JP 2943657 B2 JP 8103093 A	30-08-1999 16-04-1996
JP 2001268970	A	28-09-2001	NONE	
JP 2003204693	A	18-07-2003	US 6427794 B1 CA 2403290 A1 DE 10243217 A1 US 2003051929 A1	06-08-2002 17-03-2003 08-05-2003 20-03-2003
JP 04042764	A	13-02-1992	NONE	
JP 2001157304	A	08-06-2001	NONE	