

(19)



(11)

**EP 3 481 260 B1**

(12)

**EUROPEAN PATENT SPECIFICATION**

(45) Date of publication and mention of the grant of the patent:  
**20.09.2023 Bulletin 2023/38**

(51) International Patent Classification (IPC):  
**A47F 3/04<sup>(2006.01)</sup>**

(21) Application number: **17757872.1**

(52) Cooperative Patent Classification (CPC):  
**A47F 3/0456; A47F 2003/046**

(22) Date of filing: **06.07.2017**

(86) International application number:  
**PCT/IB2017/054074**

(87) International publication number:  
**WO 2018/007971 (11.01.2018 Gazette 2018/02)**

(54) **REFRIGERATED DISPLAY CABINET**

GEKÜHLTE AUSLAGEVITRINE

MEUBLE D'EXPOSITION RÉFRIGÉRÉ

(84) Designated Contracting States:  
**AL AT BE BG CH CY CZ DE DK EE ES FI FR GB GR HR HU IE IS IT LI LT LU LV MC MK MT NL NO PL PT RO RS SE SI SK SM TR**

(72) Inventor: **SALIN, Gian Michele**  
**36031 Due Ville (VI) (IT)**

(30) Priority: **06.07.2016 IT 201600070459 U**

(74) Representative: **De Gaspari, Andrea**  
**De Gaspari Osgnach s.r.l.**  
**Via Altinate, 33**  
**35121 Padova (IT)**

(43) Date of publication of application:  
**15.05.2019 Bulletin 2019/20**

(56) References cited:  
**WO-A1-2008/074355 CH-A- 460 066**  
**US-A- 3 115 019 US-A1- 2006 168 978**  
**US-A1- 2010 024 446**

(73) Proprietor: **Arneg S.p.A.**  
**35010 Campo San Martino (PD) (IT)**

**EP 3 481 260 B1**

Note: Within nine months of the publication of the mention of the grant of the European patent in the European Patent Bulletin, any person may give notice to the European Patent Office of opposition to that patent, in accordance with the Implementing Regulations. Notice of opposition shall not be deemed to have been filed until the opposition fee has been paid. (Art. 99(1) European Patent Convention).

## Description

**[0001]** The present invention refers in general to a refrigerated display cabinet and, in particular, to a refrigerated display cabinet that combines the characteristics both of a refrigerated display cabinet of the so-called wall-mounted type, and of a refrigerated display cabinet of the so-called island type.

**[0002]** Currently, particular display groups equipped with refrigerating systems, usually called refrigerated cabinets, for displaying consumer products, are very common. These refrigerated display groups, or refrigerated cabinets, are typically used in the field of mass distribution to display and conserve particular types of perishable products. In particular, these refrigerated display cabinets are often used in supermarkets, canteens, etc. to offer the possibility of purchasing fresh products and of keeping the products themselves in an environment at a suitable temperature.

**[0003]** WO 2008/074355 A1 discloses a refrigerating cabinet used in supermarkets, comprising a display case defining a display space, at least one shelf arranged in the display case for bearing of goods requiring refrigeration.

**[0004]** According to a terms and definitions used by standard ISO 23953-1:2015, refrigerated cabinets can be divided into:

- semi-vertical cabinet: is a refrigerated cabinet for displaying and selling with horizontal display opening in its upper part and accessible from above;
- island cabinet: is a refrigerated cabinet intended to be coupled as part of a so-called "gondola", in other words of a line of refrigerated cabinets coupled together. The "gondola" is equipped with a head refrigerated cabinet so as to allow the consumer to gain access from all sides;
- wall-mounted cabinet: is a refrigerated cabinet intended to be placed against a wall, or another refrigerated cabinet in a back-to-back configuration.

**[0005]** Each type of refrigerated cabinet has its own functional characteristics that are often different from those of other types of refrigerated cabinets. In addition, each type of refrigerated cabinet has its own advantages and defects. For example, an island cabinet can occupy more floor space with respect to a wall-mounted cabinet for the same refrigerated volume and/or amount of goods displayed. On the other hand, an island cabinet can have better accessibility to the products contained in it with respect to a wall-mounted cabinet, the upper shelves of which for storing products are often arranged at great heights from the ground.

**[0006]** Not all types of refrigerated cabinets, moreover, ensure adequate visibility of the products contained in them. This drawback can be particularly critical, for example, when the refrigerated cabinet is used for promotional sales in the retail sector.

**[0007]** The general purpose of the present invention is therefore that of making a refrigerated display cabinet, in particular a refrigerated display cabinet of the combined type, which is capable of overcoming the aforementioned drawbacks of the prior art in an extremely simple, cost-effective and particularly functional manner.

**[0008]** In detail, a purpose of the present invention is to make a refrigerated display cabinet that is capable of combining the characteristics typical of wall-mounted and island refrigerated cabinets, improving the ergonomics, in terms of visibility and accessibility of the displayed products, with respect to known refrigerated cabinets.

**[0009]** Another purpose of the invention is to make a refrigerated display cabinet that is capable of optimising the floor space occupied, in other words increasing the amount of goods displayed for the same floor space occupied, with respect to known refrigerated cabinets.

**[0010]** These and other purposes according to the present invention are accomplished by making a refrigerated display cabinet, in particular a combined refrigerated display cabinet, as outlined in claim 1.

**[0011]** Further characteristics of the invention are highlighted by the dependent claims, which are an integral part of the present description.

**[0012]** In general, the refrigerated display cabinet according to the present invention combines the typical characteristics of wall-mounted and island refrigerated cabinets, making it possible to house the products both on an upper shelf accessible from above, typical of an island cabinet, and on a plurality of display surfaces extending horizontally accessible from the front, characteristics of a wall-mounted cabinet. The refrigerated display cabinet according to the present invention makes it possible to obtain high ergonomics, in terms of visibility and accessibility of the displayed products, together with the optimisation of the floor space occupied.

**[0013]** The refrigerated display cabinet according to the present invention has particularly small dimensions in plan, which provide great versatility. The floor space occupied is indeed intended, on the one hand, to satisfy the requirement of low space occupied demanded by the market and, on the other hand, to ensure the possibility of combining and channelling, in a modular fashion, many refrigerated display cabinets. The vertical extension of the refrigerated display cabinet also makes it possible to obtain one or more further display levels, thanks to which the amount of goods displayed, for the same floor space occupied, is considerably increased.

**[0014]** The characteristics and advantages of a refrigerated display cabinet according to the present invention will become clearer from the following description, given as an example and not for limiting purposes, referring to the attached schematic drawings, in which:

figure 1 is a vertical section view of a preferred embodiment of the refrigerated display cabinet according to the present invention;  
figure 2 is a partial view, in vertical section, of the

refrigerated display cabinet of figure 1, in which the operating scheme of the aeraulic circuit is highlighted;  
 figure 3 is an enlarged view of a detail of figure 2;  
 figure 4 is another vertical section view of the refrigerated display cabinet of figure 1, which highlights the viewing possibilities of the displayed products thereof; and  
 figure 5 is a further vertical section view of the refrigerated display cabinet of figure 1, which highlights the accessibility of the displayed products.

**[0015]** It should be specified that, in the attached figures and in the following description, numerous components of the refrigerated display cabinet will not be mentioned and/or illustrated, since they are components well known to the person skilled in the art.

**[0016]** With reference in particular to figure 1, a refrigerated display cabinet according to the present invention is shown, wholly indicated with reference numeral 10. The refrigerated display cabinet 10 is provided with at least one refrigerating machine (not shown) which can be both incorporated in the refrigerated display cabinet 10 itself, and installed remotely to be able to operate with a plurality of distinct refrigerated display groups.

**[0017]** The refrigerated display cabinet 10 is thus provided with a base block 12 in which at least one display surface 14 is formed, intended to contain a plurality of products to be kept at a temperature below room temperature by means of the refrigerating machine. In the embodiment shown in the figures, each display surface 14 extends mainly horizontally, typical of island refrigerated display cabinets, and can be provided with one or more vertical dividing walls (not shown).

**[0018]** A support structure 18 for a plurality of shelves 20A and 20B extending horizontally, on which the products to be conserved rest, extends upwards from the base block 12. Each shelf 20A and 20B is arranged at a greater height with respect to the height of each display surface 14 with reference to a support plane of the base block 12. With reference to the embodiment shown in the figures, two distinct batteries of shelves 20A and 20B are provided, arranged above each display surface 14 at two respective predetermined heights from the support plane of the base block 12. Indeed, one or more upper shelves 20A can be provided, preferably delimited by respective front partitions 36, and possibly one or more lower shelves 20B, arranged between each display surface 14 and such upper shelves 20A.

**[0019]** As shown in figure 2, inside the refrigerated display cabinet 10 a plurality of delivery ducts 22 and 24 of an aeraulic circuit is provided. Each delivery duct 22 and 24 is configured to convey refrigerated air, produced by the refrigerating machine, towards each display surface 14 and towards each shelf 20A and 20B. In detail, at least one main delivery duct 22, obtained inside the support structure 18, and at least one secondary delivery duct 24, obtained inside at least part of the shelves 20A and

20B and arranged in fluid connection downstream of the main delivery duct 22 are provided.

**[0020]** Each main delivery duct 22 extends mainly vertically, whereas each secondary delivery duct 24 extends mainly horizontally, being associated with a respective shelf 20A and 20B extending horizontally, in this case the upper shelves 20A. Moreover, each main delivery duct 22 has an average passage cross section of the refrigerated air that is greater than the average passage cross section of the refrigerated air of each secondary delivery duct 24.

**[0021]** Along the vertical side surface of each main delivery duct 22 there is a plurality of slots 26 oriented to send the refrigerated air towards each display surface 14 and towards at least part of the shelves 20A and 20B. In the intersection point 28 between each main delivery duct 22 and each secondary delivery duct 24 at least one selective deflector 30 is arranged, configured to divide the flow of refrigerated air into two distinct flows, as will be specified better hereinafter.

**[0022]** The end opening portion 32 of each secondary delivery duct 24 extends along a direction substantially perpendicular to the direction of extension of the respective secondary delivery duct 24. In other words, since each secondary delivery duct 24 extends mainly horizontally, the respective end opening portion 32 extends vertically downwards to convey at least part of the refrigerated air towards each display surface 14 and towards possible lower shelves 20B arranged below such a secondary delivery duct 24. Preferably, each end opening portion 32 has an average passage cross section of the refrigerated air that is smaller than the average passage cross section of the refrigerated air of the respective secondary delivery duct 24.

**[0023]** The operation of the refrigerated display cabinet 10 is thus based on a single aeraulic circuit that simultaneously cools both each display surface 14, and each shelf 20A and 20B above. Preferably, the refrigerated display cabinet 10 is symmetrical with respect to a vertical plane passing through the support structure 18 of the shelves 20A and 20B. In other words, as shown for example in figure 1, one or more shelves 20A and 20B are provided arranged on one side of the refrigerated display cabinet 10 and one or more corresponding shelves 20A and 20B are provided arranged on the opposite side of such a refrigerated display cabinet 10. It is thus possible to provide one or more main delivery ducts 22, parallel to one another, which extend vertically inside the support structure 18.

**[0024]** The single aeraulic circuit, based mainly on the shape of dividing walls and deflectors and on the suitable sizing of the delivery ducts 22 and 24, makes it possible to suck suction air from the upper shelves 20A without the help of additional machines or tools, keeping the aeraulic circuit equally closed and stable. Thanks to the aforementioned system, the two different types of refrigerated cabinet, island and wall-mounted, can co-exist in a single body.

**[0025]** All of the apparatuses (heat exchangers, fans and valves) of the refrigerating machine necessary to keep the aeraulic circuit in normal operating conditions are housed in one or more suitable compartments 42 arranged inside the base block 12. These apparatuses, enclosed in the respective compartments 42, have identical operation to that of the corresponding apparatuses of a conventional refrigerated cabinet.

**[0026]** The overall flow of refrigerated air, with flow rate equal to  $Q_i$  and at the suction temperature, is sucked by the fans and forced to pass through the heat exchanger, which reduces the temperature thereof. Thereafter the air, cooled to delivery temperature, rises along the main delivery ducts 22, driven by the pressure induced by the ventilation system.

**[0027]** As indicated by the arrows of figure 2, a first portion of air flow rate  $Q_v$  at delivery temperature is drawn through the slots 26 to cool the products contained on the display surfaces 14. A second portion of air flow rate  $Q_r$  at delivery temperature is, on the other hand, intended for cooling the goods present on the lower shelves 20B.

**[0028]** The remaining air flow rate, equal to  $Q_f = Q_i - Q_v - Q_r$ , is driven to each selective deflector 30 positioned at the base of a respective upper shelf 20A. The selective deflector 30 is suitably perforated and shaped to further divide the air flow rate  $Q_f$  in two distinct air flow rates  $Q_1$  and  $Q_2$ .

**[0029]** A first air flow rate  $Q_1$  is channelled in every single secondary horizontal delivery duct 24 obtained inside the respective upper shelves 20A. Inside the horizontal secondary delivery duct 24 the air flow rate  $Q_1$  undergoes an acceleration, due to the narrowing of the section of such a secondary delivery duct 24 with respect to the main delivery ducts 22. Crossing a closed channel, the thermal load of the air flow rate  $Q_1$  only undergoes negligible losses. Consequently, once the end opening portion 32 of each secondary delivery duct 24 is reached, the air flow rate  $Q_1$  can be considered at delivery temperature.

**[0030]** At the end opening portion 32 the air flow rate  $Q_1$  is forced to a second acceleration by a further narrowing of the passage section. At the end opening portion 32, therefore, the air flow rate  $Q_1$  is deviated downwards and directed towards a suction grid 34 of each display surface 14, thus acting as an air curtain for the wall part of the refrigerated display cabinet 10.

**[0031]** The second air flow rate  $Q_2$  is pushed upwards inside each upper main delivery duct 22. A precise sizing of the upper slots 26 allows this second air flow rate  $Q_2$  to come out above the upper shelves 20A. The temperature of the second air flow rate  $Q_2$  is always that of delivery. Due to the braking effect of the selective deflector 30, combined with that of the slots system 26, the second air flow rate  $Q_2$  is less, not only in terms of flow rate but also as kinetic energy, with respect to the air flow rate  $Q_1$  that flows parallel in the secondary delivery duct 24 below, but remaining sufficient to adequately conserve the displayed goods.

**[0032]** At the free end of each upper shelf 20A the air flow rate  $Q_2$  has absorbed the thermal load of the goods, going to the suction temperature, and reaches a front partition 36, preferably transparent. The front partition 36 extends vertically and is fixedly connected to a respective upper shelf 20A at the end opening portion 32 of the respective secondary delivery duct 24. A suction channel 38 extending vertically is arranged between each upper shelf 20A and the respective front partition 36. The air flow rate  $Q_2$ , deviated by the front partition 36, is thus sent above the suction channel 38.

**[0033]** The suction channel 38 is separated from the end opening portion 32 through a dividing wall 40 of minimal thickness. The air flow rate  $Q_1$ , greater with respect to the air flow rate  $Q_2$ , comes out from the end opening portion 32 at high speed. The kinetic energy of the air flow rate  $Q_1$  thus generates a natural driving force close to its limit. Keeping the suction channel 38 a minimum distance from the end opening portion 32 makes it possible to subject the air flow rate  $Q_2$  to the aforementioned driving force.

**[0034]** Therefore, at the outlet mouth of the suction channel 38 the air flow rate  $Q_2$  is subjected to three different actions:

- a horizontal pressure thrust, generated by the fans, which allowed the flow of air to cross the secondary delivery duct 24;
- the force of gravity, which contributes to thrusting the flow of air downwards, since such a flow of air, being at a low temperature, has a specific weight greater than the mass of hot air above;
- a downward driving force, generated at the end opening portion 32.

**[0035]** The resulting effect is the sucking of the air flow rate  $Q_2$ , which is sucked through the suction channel 38 and mixes with the air flow rate  $Q_1$ , which drives it downwards. The kinetic load of the air flow rate  $Q_1$  is regulated by the shape of the selective deflector 30, by the size of the section of the secondary delivery duct 24 and by the size of the end opening portion 32, so as to be sufficient to capture the air flow rate  $Q_2$  and still conserve the energy to constitute a curtain of air suitable for the refrigeration of the lower shelves 20B.

**[0036]** The ratio in dimensional terms between the air flow rates  $Q_1$  and  $Q_2$  is regulated by the shape of the selective deflector 30, so that the air flow rate  $Q_1$  is much greater than the air flow rate  $Q_2$ , in the limits to in any case ensure the refrigerating effect of such an air flow rate  $Q_2$ . In this way, the thermal impact due to the mixing of the air flow rate  $Q_2$ , at suction temperature, with the air flow rate  $Q_1$ , at delivery temperature, is reduced. The result is that of obtaining a resulting air flow rate  $Q_c = Q_1 + Q_2$ , of temperature very close to that of  $Q_1$ , thus ensuring the refrigerating capability of the curtain. At the end of the aeraulic circuit, the resulting air flow rate  $Q_c$ , which forms a downward curtain, joins with the air flow rates  $Q_r$

and  $Q_v$ , which respectively supply the lower shelves 20B and the display surfaces 14 below. This resulting air flow rate  $Q_c$  is finally sucked by the fans through a lower suction grid 34, arranged at the front end of each display surface 14.

**[0037]** Preferably, based on an ergonomic study on the refrigerated display cabinet 10, the results of which can be seen in figures 3 and 4, the height of each upper shelf 20A, measured from the support plane of the base block 12, is about 1100 mm. This value is devised to combine the excellent visibility of the "island" section, consisting of the display surface of the shelf 20A, with the large load capacity of the vertical section, consisting of the shelf 20B and the display surface 14, without precluding easy accessibility to the goods displayed in each of the levels.

**[0038]** As far as the height of the display surfaces 14 is concerned, a measurement of about 550 mm from the support plane of the base block 12 ensures the possibility of housing inside the base block 12 itself an incorporated refrigerating machine, so as to make the refrigerated display cabinet 10 independent in terms of refrigeration and allowing easy arrangement thereof inside any shop. This solution is an alternative to the remote connection to a refrigerating station.

**[0039]** It has thus been seen that the refrigerated display cabinet according to the present invention achieves the purposes highlighted earlier, in particular obtaining the following advantages:

- the aforementioned height from the ground of 1100 mm of the upper shelves 20A makes it possible to have the goods at a raised level making a strong visual impression;
- in order to reduce the visual impact of the refrigerated display cabinet 10 in favour of product visibility numerous partially or totally transparent components are provided. The consumer can thus have total visibility on all of the shelves 20A and 20B and on all of the display surfaces 14 of the base block 12. Being, indeed, in frontal position with respect to the refrigerated display cabinet 10 (figure 4), the at least partial transparency of the support structure 18 and of the shelves 20A and 20B makes it possible to see the goods housed on the opposite side. On the other hand, being in lateral position, the visibility on both sides is ensured by the transparency of the side;
- the illumination of the upper shelves 20A is ensured by the exposure to ambient light, exploited in the best possible way thanks to the absence of shaded areas;
- the illumination of the display surfaces 14, already ensured by the light effect due to the many transparencies, can be increased by the optional installation of luminescent bars using LED technology both under the upper shelves 20A, to illuminate the lower ones 20B, and under the lower shelves 20B, to illuminate the display surfaces 14;
- the height from ground of the partitions 36 of the

upper shelves 20A, which coincides with the overall height from ground of the refrigerated display cabinet 10, is preferably less than 1300 mm, so as to allow the consumer to easily access the goods displayed on the upper shelves 20A, avoiding unnatural movements (see figure 5);

- the height from ground of 550 mm of the display surfaces 14, together with the lowered height of the respective front partitions 46, promotes access to the goods in conditions of full convenience, without forcing the consumer to bend over excessively;
- the lower shelves 20B provide a further refrigerated surface on which to position the goods;
- a possible top shelf 16, formed above the support structure 18 and totally transparent, can form a non-refrigerated support structure, also possibly accessible to the consumer;
- the refrigerated display cabinet 10 provides for the possible scenario of being channelled on each side with another refrigerated display cabinet 10 of the same type, forming a "gondola" line typical of an island, accessible on both sides. Alternatively, the refrigerated display cabinet 10 can be used singularly, closing the sides with suitable transparent side walls (not shown). Such side walls are devised to allow maximum visibility on the products displayed in the vertical part, as well as total accessibility to the upper shelves 20A from all four sides of the refrigerated display cabinet 10, in turn a characteristic of an island refrigerated cabinet.

**[0040]** The refrigerated display cabinet thus conceived therefore defined by the attached claims.

## Claims

### 1. Refrigerated display cabinet (10) comprising:

- at least one refrigerating machine;
- a base block (12) in which at least one display surface (14) is obtained, designed to contain a plurality of products to be kept at a temperature below room temperature by means of the refrigerating machine;
- a support structure (18) for a plurality of shelves (20A, 20B) extending horizontally, on which the products to be conserved rest, said plurality of shelves (20A, 20B) comprising one or more upper shelves (20A), said support structure (18) extending upwards from the base block (12) so that each shelf (20A, 20B) is arranged at a greater height with respect to the height of each display surface (14) with reference to a support plane of the base block (12);
- wherein said one or more upper shelves (20A) are accessible from above, and wherein the display cabinet (10) comprises a plurality of delivery

ducts (22, 24) of an aeraulic circuit, arranged to convey refrigerated air ( $Q_i$ ), produced by the refrigerating machine, towards each display surface (14) and towards each shelf (20A, 20B), said plurality of delivery ducts (22, 24) comprising:

- at least one main delivery duct (22), obtained inside the support structure (18) and arranged to send a first amount of refrigerated air ( $Q_v, Q_r, Q_2$ ) towards each display surface (14) and towards at least part of the shelves (20A, 20B); and
- at least one secondary delivery duct (24), obtained inside at least part of the shelves (20A, 20B) and arranged in fluid connection downstream of the main delivery duct (22), each secondary delivery duct (24) being arranged to send a second amount of refrigerated air ( $Q_1$ ) towards each display surface (14) and towards at least part of the shelves (20A, 20B), so that said first amount of refrigerated air ( $Q_v, Q_r, Q_2$ ) can be at least partially mixed with said second amount of refrigerated air ( $Q_1$ );
- the display cabinet (10) comprises two distinct batteries of shelves (20A, 20B), arranged above each display surface (14) at two respective predetermined heights from the support plane of the base block (12), in which one or more upper shelves (20A) and one or more lower shelves (20B) are provided, arranged between each display surface (14) and said upper shelves (20A);
- the end opening portion (32) of each secondary delivery duct (24) extends along a direction substantially perpendicular to the direction of extension of the respective secondary delivery duct (24), said end opening portion (32) extending vertically downwards to convey at least part of the refrigerated air ( $Q_1$ ) towards each display surface (14) and towards the lower shelves (20B) arranged below said secondary delivery duct (24);
- each upper shelf (20A) is delimited by a partition (36) extending vertically, fixedly connected to said upper shelf (20A) at the respective end opening portion (32);
- between each upper shelf (20A) and the respective front partition (36) a suction channel (38) is arranged extending vertically, said front partition (36) deviating a part ( $Q_2$ ) of said first amount of refrigerated air ( $Q_v, Q_r, Q_2$ ) to send it above the suction channel (38) in order to suck the air flow rate ( $Q_2$ ), which is sucked through the suction channel (38) and mix the air flow rate ( $Q_2$ ) with the air flow rate ( $Q_1$ ), which drives

it downwards;

**characterized in that**

along the vertical side surface of each main delivery duct (22) there is a plurality of slots (26) oriented to send the refrigerated air ( $Q_v, Q_r, Q_2$ ) towards each display surface (14) and towards at least part of the shelves (20A, 20B);

**and in that**

the height from ground of the partitions (36) of the upper shelves (20A), which coincides with the overall height from ground of the refrigerated display cabinet (10) is preferably less than 1300 mm, so as to allow the consumer to easily access the goods displayed on the upper shelves (20A) avoiding unnatural movements.

2. Refrigerated display cabinet (10) according to claim 1, **characterized in that** each main delivery duct (22) extends mainly vertically, whereas each secondary delivery duct (24) extends mainly horizontally, being associated with a respective upper shelf (20A) extending horizontally.
3. Refrigerated display cabinet (10) according to claim 2, **characterized in that** each main delivery duct (22) has an average passage cross section of the refrigerated air ( $Q_i$ ) that is greater than the average passage cross section of the refrigerated air ( $Q_1$ ) of each secondary delivery duct (24).
4. Refrigerated display cabinet (10) according to any one of claims 1 to 3, **characterised in that** at the intersection point (28) between each main delivery duct (22) and each secondary delivery duct (24) at least one selective deflector (30) is arranged, configured to divide the flow of refrigerated air ( $Q_f$ ) into two distinct flows ( $Q_1, Q_2$ ).
5. Refrigerated display cabinet (10) according to claim 1, **characterised in that** each end opening portion (32) has an average passage cross section of the refrigerated air ( $Q_1$ ) that is less than the average passage cross section of the refrigerated air ( $Q_1$ ) of the respective secondary delivery duct (24).
6. Refrigerated display cabinet (10) according to claim 1, **characterised in that** the suction channel (38) is separated from the end opening portion (32) through a dividing wall (40) of thickness such as to allow said part ( $Q_2$ ) of said first amount of refrigerated air ( $Q_v, Q_r, Q_2$ ) to be mixed with said second amount of refrigerated air ( $Q_1$ ), obtaining a resulting amount of air ( $Q_c$ ) that forms a curtain of air configured for refrigerating the lower shelves (20B).
7. Refrigerated display cabinet (10) according to claim 6, **characterised in that** it comprises one or more

compartments (42) arranged inside the base block (12) and containing the apparatuses of the refrigerating machine necessary to keep the aeraulic circuit in normal operating conditions.

- 5
8. Refrigerated display cabinet (10) according to claim 7, **characterised in that** each display surface (14) is provided with a suction grid (34) configured to convey said resulting amount of air ( $Q_c$ ) towards a corresponding lower suction grid (34) arranged at the front end of each display surface (14). 10
9. Refrigerated display cabinet (10) according to any one of the previous claims, **characterised in that** it is symmetrical with respect to a vertical plane passing through the support structure (18) of the shelves (20A, 20B), so as to provide one or more shelves (20A, 20B) arranged on one side of the refrigerated display cabinet (10) and one or more corresponding shelves (20A, 20B) arranged on the opposite side of said refrigerated display cabinet (10). 15 20
10. Refrigerated display cabinet (10) according to any one of the previous claims, **characterized in that** it comprises a top shelf (16), placed above the support structure (18) and configured to form a non-refrigerated support surface. 25

#### Patentansprüche 30

1. Kühlvitrine (10), bestehend aus:

- mindestens einer Kältemaschine;
  - einem Basisblock (12), in den mindestens ein Auslagefläche (14) eingearbeitet ist, die dazu bestimmt ist, eine Vielzahl von Produkten zu enthalten, die mit Hilfe der Kältemaschine auf einer Temperatur unterhalb der Raumtemperatur gehalten werden sollen; 35 40
  - einer Tragkonstruktion (18) für eine Vielzahl von sich horizontal erstreckenden Fachböden (20A, 20B), auf denen die zu konservierenden Produkte liegen, wobei die besagte Vielzahl von Fachböden (20A, 20B) einen oder mehrere obere Fachböden (20A) umfasst, wobei sich die besagte Tragkonstruktion (18) von dem Basisblock (12) nach oben erstreckt, sodass jeder Fachboden (20A, 20B) in einer größeren Höhe im Verhältnis zur Höhe jeder Auslagefläche (14) in Bezug auf eine Stützebene des Basisblocks (12) angeordnet ist; 45 50
- wobei die besagten ein oder mehreren oberen Fachböden (20A) von oben zugänglich sind, und wobei die Kühlvitrine (10) eine Vielzahl von Versorgungskanälen (22, 24) eines Luftkreislaufs umfasst, die so angeordnet sind, dass sie gekühlte Luft ( $Q_i$ ), die von der Kältemaschine
- 55

erzeugt wird, zu jeder Auslagefläche (14) und zu jedem Fachboden (20A, 20B) leiten, wobei die besagte Vielzahl von Versorgungskanälen (22, 24) Folgendes umfasst:

- mindestens einen Hauptversorgungs kanal (22), der im Inneren der Tragkonstruktion (18) eingearbeitet und so angeordnet ist, dass er eine erste Menge an gekühlter Luft ( $Q_v, Q_r, Q_2$ ) zu jeder Auslagefläche (14) und zu mindestens einem Teil der Fachböden (20A, 20B) leitet; und
- mindestens einen Nebenversorgungs kanal (24), der im Inneren mindestens eines Teils der Fachböden (20A, 20B) eingearbeitet und in Fluidverbindung stromabwärts des Hauptversorgungs kanals (22) angeordnet ist, wobei jeder Nebenversorgungs kanal (24) so beschaffen ist, dass er eine zweite Menge an gekühlter Luft ( $Q_1$ ) zu jeder Auslagefläche (14) und zu mindestens einem Teil der Fachböden (20A, 20B) leitet, sodass die besagte erste Menge an gekühlter Luft ( $Q_v, Q_r, Q_2$ ) zumindest teilweise mit der besagten zweiten Menge an gekühlter Luft ( $Q_1$ ) gemischt werden kann;
- die Kühlvitrine (10) umfasst zwei getrennte Fachboden-Einheiten (20A, 20B), die über jeder Auslagefläche (14) in zwei jeweiligen vorbestimmten Höhen von der Stützebene des Basisblocks (12) angeordnet sind, in denen ein oder mehrere obere Fachböden (20A) und ein oder mehrere untere Fachböden (20B) vorgesehen sind, die zwischen jeder Auslagefläche (14) und den besagten oberen Fachböden (20A) angeordnet sind;
- der Endöffnungsabschnitt (32) jedes Nebenversorgungs kanals (24) erstreckt sich entlang einer Richtung, die im Wesentlichen senkrecht zur Erstreckungsrichtung des jeweiligen Nebenversorgungs kanals (24) ist, wobei sich der besagte Endöffnungsabschnitt (32) vertikal nach unten erstreckt, um zumindest einen Teil der gekühlten Luft ( $Q_1$ ) zu jeder Auslagefläche (14) und zu den unteren Fachböden (20B), die unter dem besagten Nebenversorgungs kanal (24) angeordnet sind, zu leiten;
- jeder obere Fachboden (20A) ist durch eine sich vertikal erstreckende Trennwand (36) begrenzt, die mit dem besagten oberen Fachboden (20A) an dem jeweiligen Endöffnungsabschnitt (32) fest verbunden ist;
- zwischen jedem oberen Fachboden (20A) und der jeweiligen vorderen Trennwand (36) ist ein Saugkanal (38) angeordnet, der sich vertikal erstreckt, wobei die besagte vordere Trennwand (36) einen Teil ( $Q_2$ ) der

besagten ersten Menge an gekühlter Luft ( $Q_v, Q_r, Q_2$ ) umführt, um diese über den Ansaugkanal (38) zu leiten und den Luftstromanteil ( $Q_2$ ), der durch den Ansaugkanal (38) angesaugt wird, anzusaugen, und den Luftstromanteil ( $Q_2$ ) mit dem Luftstromanteil ( $Q_1$ ), der ihn nach unten treibt, zu mischen,

**dadurch gekennzeichnet, dass:**

sich entlang der vertikalen Seitenfläche jedes Hauptversorgungskanals (22) eine Vielzahl von Schlitzfenstern (26) befindet, die so ausgerichtet sind, dass sie die gekühlte Luft ( $Q_v, Q_r, Q_2$ ) zu jeder Auslagefläche (14) und zu mindestens einem Teil der Fachböden (20A, 20B) leiten;

und **dadurch, dass**

die Höhe der Trennwände (36) der oberen Fachböden (20A) vom Boden aus, die mit der Gesamthöhe der Kühlvitrine (10) über dem Boden übereinstimmt, vorzugsweise weniger als 1300 mm beträgt, damit die Kundschaft leicht auf die in den oberen Fachböden (20A) ausgestellten Waren zugreifen kann und unergonomische Bewegungen vermieden werden.

2. Kühlvitrine (10) nach Patentanspruch 1, **dadurch gekennzeichnet, dass** jeder Hauptversorgungskanal (22) sich hauptsächlich vertikal erstreckt, während jeder Nebenversorgungskanal (24) sich hauptsächlich horizontal erstreckt, wobei er mit einem entsprechenden oberen Fachboden (20A) verbunden ist, der sich horizontal erstreckt.

3. Kühlvitrine (10) nach Patentanspruch 2, **dadurch gekennzeichnet, dass** jeder Hauptversorgungskanal (22) einen mittleren Durchlassquerschnitt der gekühlten Luft ( $Q_i$ ) aufweist, der größer ist als der mittlere Durchlassquerschnitt der gekühlten Luft ( $Q_1$ ) jedes Nebenversorgungskanals (24).

4. Kühlvitrine (10) nach jeglichem der Patentansprüche 1 bis 3, **dadurch gekennzeichnet, dass** am Schnittpunkt (28) zwischen jedem Hauptversorgungskanal (22) und jedem Nebenversorgungskanal (24) mindestens ein selektiver Abweiser (30) angeordnet ist, der so konfiguriert ist, dass er den Kühlluftstrom ( $Q_f$ ) in zwei unterschiedliche Ströme ( $Q_1, Q_2$ ) aufteilt.

5. Kühlvitrine (10) nach Patentanspruch 1, **dadurch gekennzeichnet, dass** jeder Endöffnungsabschnitt (32) einen mittleren Durchlassquerschnitt der Kühlluft ( $Q_1$ ) aufweist, der kleiner ist als der mittlere Durchlassquerschnitt der Kühlluft ( $Q_1$ ) des jeweiligen Nebenversorgungskanals (24).

6. Kühlvitrine (10) nach Patentanspruch 1, **dadurch gekennzeichnet, dass** der Ansaugkanal (38) von dem Endöffnungsabschnitt (32) durch eine Trennwand (40) mit einer solchen Dicke getrennt ist, so dass der besagte Teil ( $Q_2$ ) der ersten Menge an gekühlter Luft ( $Q_v, Q_r, Q_2$ ) mit der besagten zweiten Menge an gekühlter Luft ( $Q_1$ ) gemischt wird, wobei eine resultierende Luftmenge ( $Q_c$ ) erhalten wird, die einen Luftvorhang bildet, der zum Kühlen der unteren Fachböden (20B) konfiguriert ist.

7. Kühlvitrine (10) nach Patentanspruch 6, **dadurch gekennzeichnet, dass** sie ein oder mehrere Fächer (42) umfasst, die im Inneren des Basisblocks (12) angeordnet sind und die Geräte der Kältemaschine enthalten, die erforderlich sind, um den Luftkreislauf unter normalen Betriebsbedingungen zu halten.

8. Kühlvitrine (10) nach Patentanspruch 7, **dadurch gekennzeichnet, dass** jede Auslagefläche (14) mit einem Ansauggitter (34) versehen ist, das so konfiguriert ist, dass es die besagte resultierende Luftmenge ( $Q_c$ ) zu einem entsprechenden unteren Ansauggitter (34) leitet, das am vorderen Ende jeder Auslagefläche (14) angeordnet ist.

9. Kühlvitrine (10) nach jeglichem der vorhergehenden Patentansprüche, **dadurch gekennzeichnet, dass** sie in Bezug auf eine vertikale Ebene, die durch die Tragkonstruktion (18) der Fachböden (20A, 20B) verläuft, symmetrisch ist, sodass ein oder mehrere auf einer Seite der Kühlvitrine (10) angeordnete Fachböden (20A, 20B) und ein oder mehrere auf der gegenüberliegenden Seite der besagten Kühlvitrine (10) angeordnete, entsprechende Fachböden (20A, 20B) vorgesehen werden.

10. Kühlvitrine (10) nach jeglichem der vorhergehenden Patentansprüche, **dadurch gekennzeichnet, dass** sie einen Top-Fachboden (16) umfasst, der oberhalb der Tragkonstruktion (18) angeordnet und so konfiguriert ist, dass er eine nicht gekühlte Auflagefläche bildet.

## Revendications

1. Vitrine réfrigérée (10) comprenant :

- au moins une machine frigorifique ;
- un bloc de base (12) dans lequel se trouve au moins une surface d'exposition (14) destinée à contenir une pluralité de produits à maintenir à une température inférieure à la température ambiante au moyen de la machine frigorifique ;
- une structure de support (18) pour une pluralité d'étagères (20A, 20B) s'étendant horizontalement, sur lesquelles reposent les produits à con-

server, ladite pluralité d'étagères (20A, 20B) comprenant une ou plusieurs étagères supérieures (20A), ladite structure de support (18) s'étendant vers le haut à partir du bloc de base (12) de sorte que chaque étagère (20A, 20B) est disposée à une hauteur supérieure par rapport à la hauteur de chaque surface d'exposition (14) en référence à un plan de support du bloc de base (12) ;  
 où lesdites une ou plusieurs étagères supérieures (20A) sont accessibles par le haut, et où la vitrine (10) comprend une pluralité de conduits de distribution (22, 24) d'un circuit aéraulique, disposés pour acheminer l'air réfrigéré (Qi), produit par la machine frigorifique, vers chaque surface d'exposition (14) et vers chaque étagère (20A, 20B),  
 cette pluralité de conduits de refoulement (22, 24) comprenant :

- au moins un conduit de distribution principal (22), réalisé à l'intérieur de la structure de support (18) et disposé de manière à envoyer une première quantité d'air réfrigéré ( $Q_v$ ,  $Q_r$ ,  $Q_2$ ) vers chaque surface d'exposition (14) et vers au moins une partie des étagères (20A, 20B) ; et
- au moins un conduit de refoulement secondaire (24), réalisé à l'intérieur d'au moins une partie des étagères (20A, 20B) et disposé en connexion fluide en aval du conduit de refoulement principal (22), chaque conduit de refoulement secondaire (24) étant disposé de manière à envoyer une deuxième quantité d'air réfrigéré ( $Q_1$ ) vers chaque surface d'exposition (14) et vers au moins une partie des étagères (20A, 20B), de sorte que ladite première quantité d'air réfrigéré ( $Q_v$ ,  $Q_r$ ,  $Q_2$ ) puisse être au moins partiellement mélangée avec ladite deuxième quantité d'air réfrigéré ( $Q_1$ ) ;
- la vitrine (10) comprend deux batteries distinctes d'étagères (20A, 20B), disposées au-dessus de chaque surface d'exposition (14) à deux hauteurs respectives prédéterminées par rapport au plan de support du bloc de base (12), dans lesquelles sont prévues une ou plusieurs étagères supérieures (20A) et une ou plusieurs étagères inférieures (20B), disposées entre chaque surface d'exposition (14) et lesdites étagères supérieures (20A) ;
- la partie d'ouverture finale (32) de chaque conduit de refoulement secondaire (24) s'étend le long d'une direction essentiellement perpendiculaire à la direction d'extension du respectif conduit de refoulement secondaire (24), ladite partie d'ouverture fina-

le (32) s'étendant verticalement vers le bas pour acheminer au moins une partie de l'air réfrigéré ( $Q_1$ ) vers chaque surface d'exposition (14) et vers les étagères inférieures (20B) disposées en dessous dudit conduit de distribution secondaire (24) ;  
 - chaque étagère supérieure (20A) est délimitée par une cloison (36) s'étendant verticalement, reliée de manière fixe à ladite étagère supérieure (20A) à hauteur de la respective partie d'ouverture finale (32) ;  
 - entre chaque étagère supérieure (20A) et la cloison avant respective (36), un canal d'aspiration (38) s'étend verticalement, ladite cloison avant (36) déviant une partie ( $Q_2$ ) de ladite première quantité d'air réfrigéré ( $Q_v$ ,  $Q_r$ ,  $Q_2$ ) pour l'envoyer au-dessus du canal d'aspiration (38) afin d'aspirer le débit d'air ( $Q_2$ ), qui est aspiré à travers le canal d'aspiration (38) et de mélanger le débit d'air ( $Q_2$ ) avec le débit d'air ( $Q_1$ ), qui l'entraîne vers le bas ;

#### caractérisée en ce que

le long de la surface latérale verticale de chaque conduit de distribution principal (22), il y a une pluralité de fentes (26) orientées pour envoyer l'air réfrigéré ( $Q_v$ ,  $Q_r$ ,  $Q_2$ ) vers chaque surface d'exposition (14) et vers au moins une partie des étagères (20A, 20B) ;

#### et en ce que

la hauteur par rapport au sol des cloisons (36) des étagères supérieures (20A), qui coïncide avec la hauteur totale par rapport au sol de la vitrine réfrigérée (10), est de préférence inférieure à 1 300 mm, de manière à permettre au consommateur d'accéder aisément aux marchandises exposées sur les étagères supérieures (20A) en évitant des mouvements non naturels.

2. Vitrine réfrigérée (10) selon la revendication 1, **caractérisée en ce que** chaque conduit de distribution principal (22) s'étend principalement verticalement, tandis que chaque conduit de distribution secondaire (24) s'étend principalement horizontalement, étant associé à une étagère supérieure respective (20A) s'étendant horizontalement.
3. Vitrine réfrigérée (10) selon la revendication 2, **caractérisée en ce que** chaque conduit de distribution principal (22) présente une section transversale moyenne de passage de l'air réfrigéré (Qi) qui est supérieure à la section transversale de passage moyenne de l'air réfrigéré ( $Q_1$ ) de chaque conduit de distribution secondaire (24).
4. Vitrine réfrigérée (10) selon l'une quelconque des

- revendications de 1 à 3, **caractérisée en ce qu'**au point d'intersection (28) entre chaque conduit de refoulement principal (22) et chaque conduit de refoulement secondaire (24) est disposé au moins un déflecteur sélectif (30) configuré pour diviser le flux d'air réfrigéré ( $Q_f$ ) en deux flux distincts ( $Q_1$ ,  $Q_2$ ). 5
5. Vitrine réfrigérée (10) selon la revendication 1, **caractérisée en ce que** chaque partie d'ouverture finale (32) présente une section transversale moyenne de passage de l'air réfrigéré ( $Q_1$ ) qui est inférieure à la section transversale moyenne de passage de l'air réfrigéré ( $Q_1$ ) du respectif conduit de refoulement secondaire (24). 10 15
6. Vitrine réfrigérée (10) selon la revendication 1, **caractérisée en ce que** le canal d'aspiration (38) est séparé de la partie d'ouverture finale (32) par une paroi de séparation (40) ayant une épaisseur telle qu'elle permet à ladite partie ( $Q_2$ ) de ladite première quantité d'air réfrigéré ( $Q_v$ ,  $Q_r$ ,  $Q_2$ ) d'être mélangée à ladite deuxième quantité d'air réfrigéré ( $Q_1$ ), en obtenant une quantité d'air résultante ( $Q_c$ ) qui forme un rideau d'air configuré pour réfrigérer les étagères inférieures (20B). 20 25
7. Vitrine réfrigérée (10) selon la revendication 6, **caractérisée en ce qu'**elle comprend un ou plusieurs compartiments (42) disposés à l'intérieur du bloc de base (12) et contenant les appareils de la machine frigorifique nécessaires au maintien du circuit aérodynamique dans des conditions de fonctionnement normales. 30
8. Vitrine réfrigérée (10) selon la revendication 7, **caractérisée en ce que** chaque surface d'exposition (14) est pourvue d'une grille d'aspiration (34) configurée pour acheminer ladite quantité d'air résultante ( $Q_c$ ) vers une grille d'aspiration inférieure correspondante (34) disposée au niveau de l'extrémité avant de chaque surface d'exposition (14). 35 40
9. Vitrine réfrigérée (10) selon l'une quelconque des revendications précédentes, **caractérisée en ce qu'**elle est symétrique par rapport à un plan vertical passant par la structure de support (18) des étagères (20A, 20B), de manière à présenter une ou plusieurs étagères (20A, 20B) disposées sur un côté de la vitrine réfrigérée (10) et une ou plusieurs étagères correspondantes (20A, 20B) disposées sur le côté opposé de ladite vitrine réfrigérée (10). 45 50
10. Vitrine réfrigérée (10) selon l'une quelconque des revendications précédentes, **caractérisée en ce qu'**elle comprend une étagère au sommet (16), placée au-dessus de la structure de support (18) et configurée de manière à former une surface de support non réfrigérée. 55

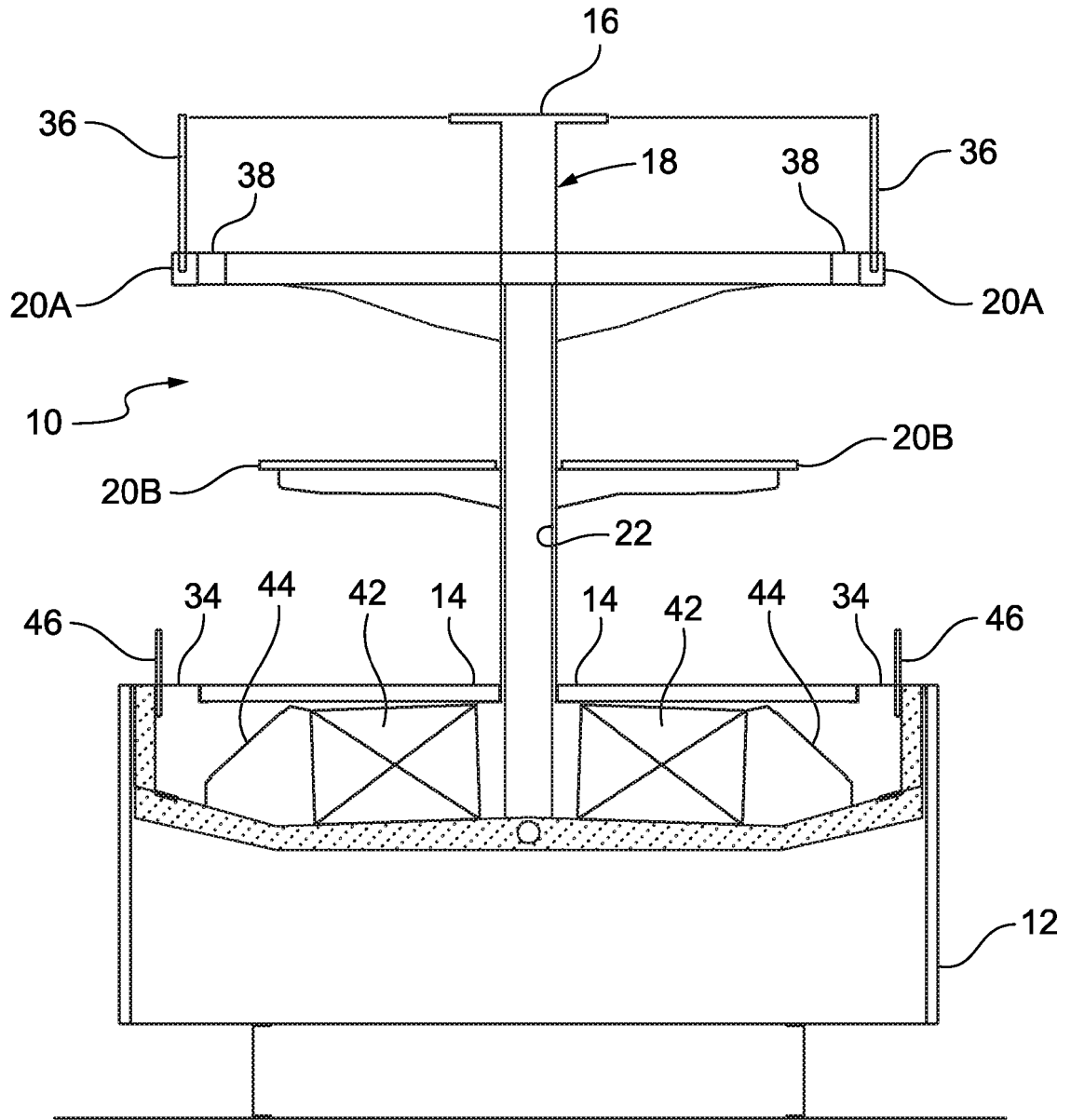

Fig. 1

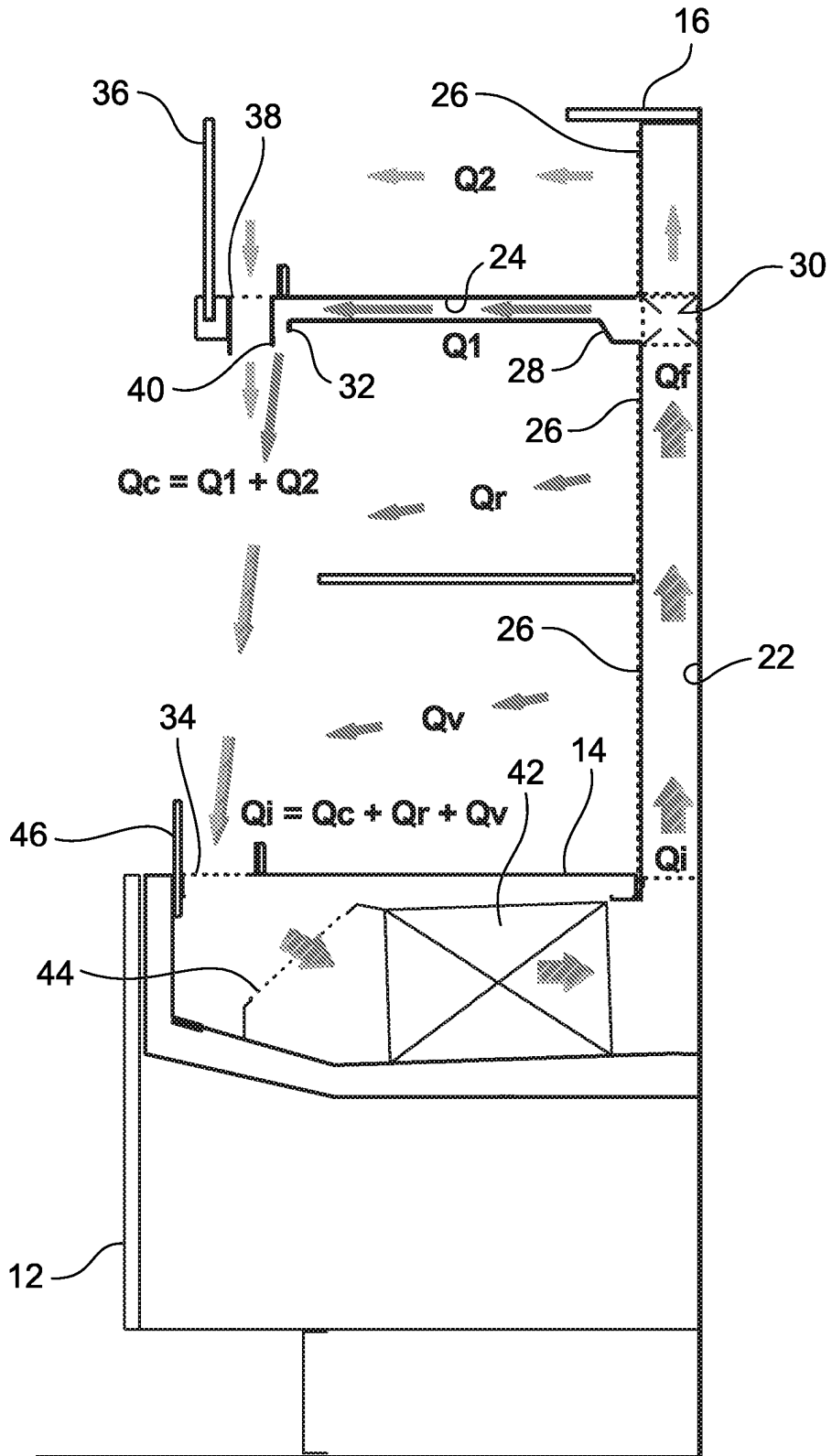
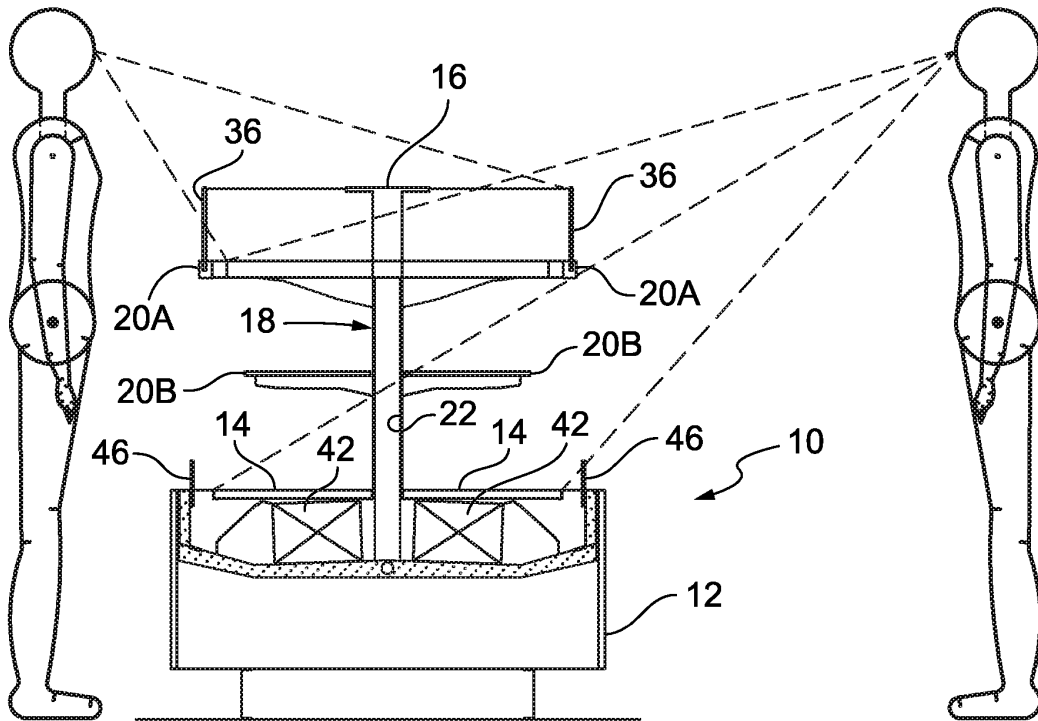
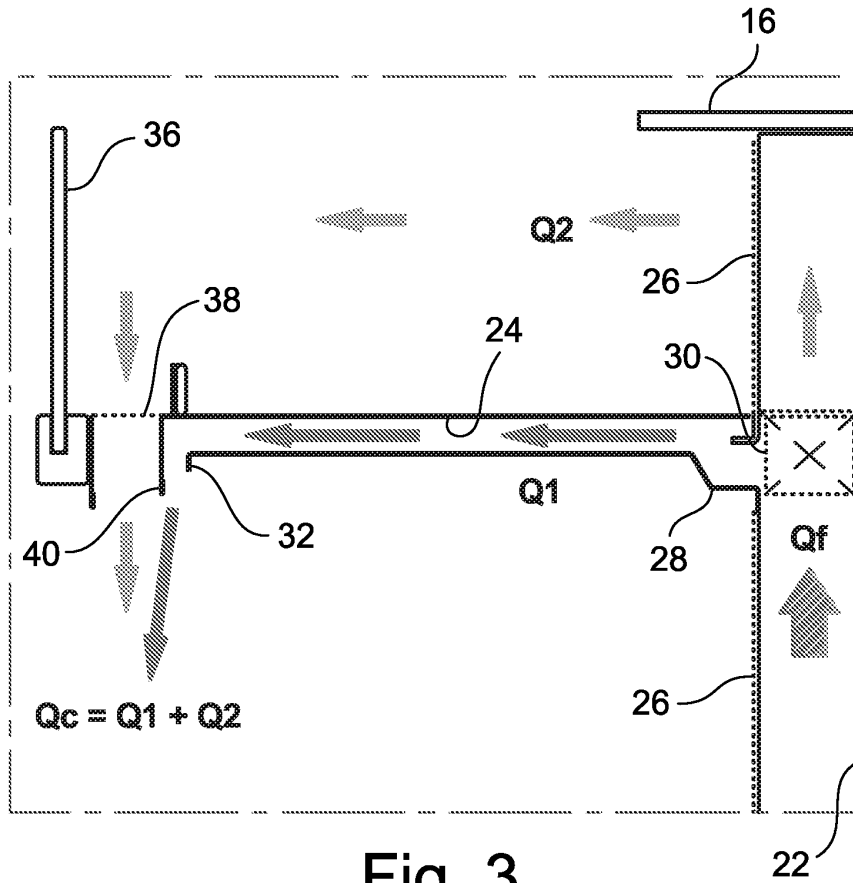

Fig. 2



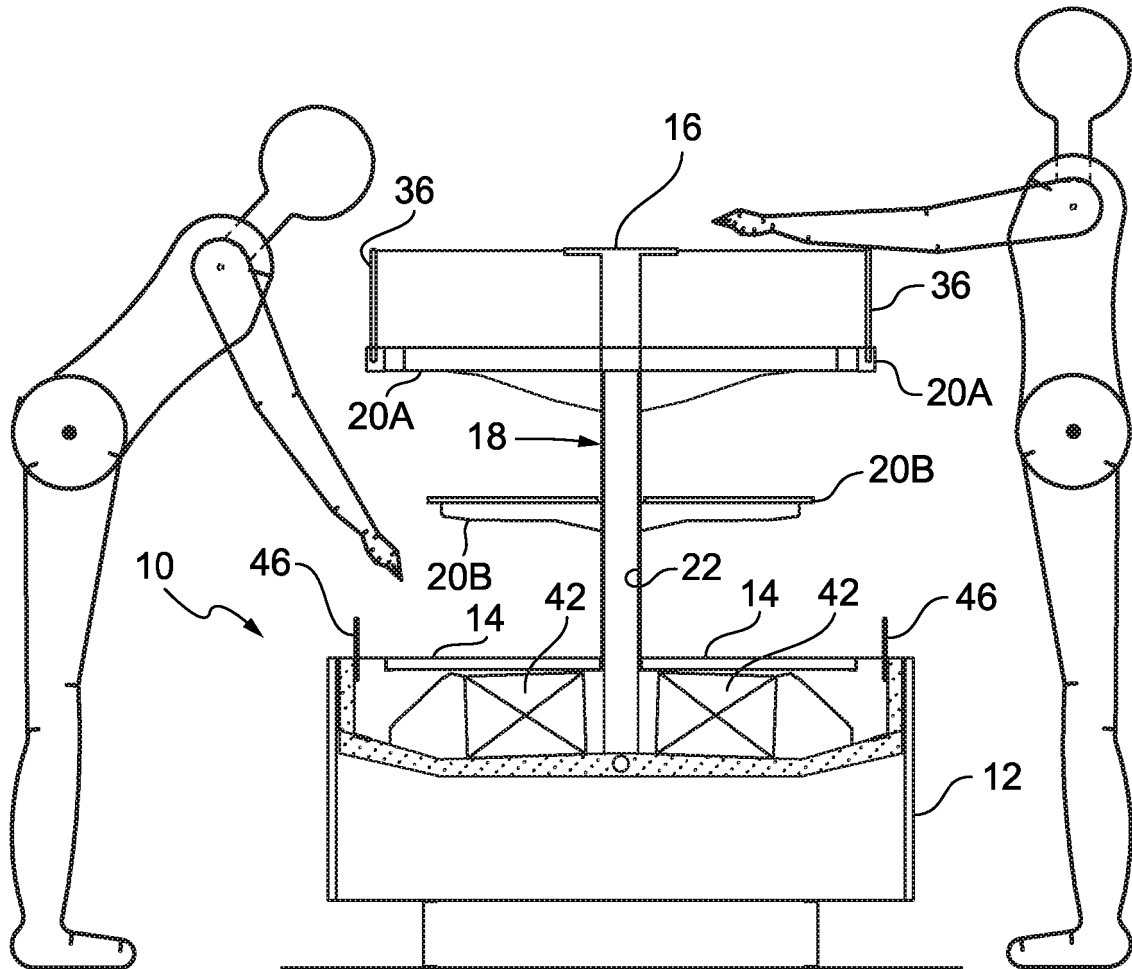

Fig. 5

**REFERENCES CITED IN THE DESCRIPTION**

*This list of references cited by the applicant is for the reader's convenience only. It does not form part of the European patent document. Even though great care has been taken in compiling the references, errors or omissions cannot be excluded and the EPO disclaims all liability in this regard.*

**Patent documents cited in the description**

- WO 2008074355 A1 [0003]