



US00D484698S

(12) **United States Design Patent** (10) **Patent No.:** **US D484,698 S**
Mueller (45) **Date of Patent:** **** Jan. 6, 2004**

(54) **LIMOUSINE BASKET**

Primary Examiner—Louis S. Zarfaz
Assistant Examiner—Deanne Levy
(74) *Attorney, Agent, or Firm*—Richard A. Joel

(76) **Inventor:** **Maryann Mueller**, 44B Mansion Blvd.,
Delmar, NY (US) 12054

(**) **Term:** **14 Years**

(57) **CLAIM**

(21) **Appl. No.:** **29/175,011**

The ornamental design for a limousine basket, as shown and described.

(22) **Filed:** **Jan. 28, 2003**

DESCRIPTION

(51) **LOC (7) Cl.** **03-01**

(52) **U.S. Cl.** **D3/304; D3/271**

(58) **Field of Search** **D3/304, 270, 271;**
D12/91, 92; D21/548, 551

This is a refiling of Ser. No. 29/141/106 filed Apr. 30, 2001 now abandoned.

(56) **References Cited**

FIG. 1 is a perspective view of the limousine basket showing the embodiment of the invention;

U.S. PATENT DOCUMENTS

FIG. 2 is a top view of the limousine basket of **FIG. 1**;

D54,589 S	*	3/1920	Bradfield	D12/91
D86,441 S	*	3/1932	Decker	D21/548
D209,663 S	*	12/1967	Sangimino	D12/91
D280,223 S	*	8/1985	Barbato et al.	D21/551
D362,788 S	*	10/1995	Hartman	D21/548
D434,222 S	*	11/2000	Shih	D3/271

FIG. 3 is a bottom view of the limousine basket of **FIG. 1**;

FIG. 4 is a left side view of the limousine basket of **FIG. 1**;

OTHER PUBLICATIONS

Sears Catalog 1986, Item "B" wood antique-look car valet
p. 26.*

FIG. 5 is a right side view of the limousine basket of **FIG. 1**;
and,

FIG. 6 is a rear view of the limousine basket of **FIG. 1**.

* cited by examiner

1 Claim, 6 Drawing Sheets

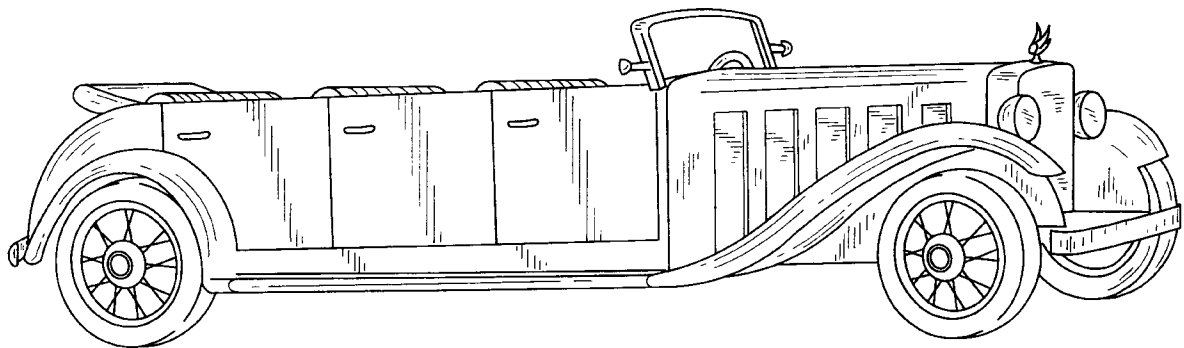

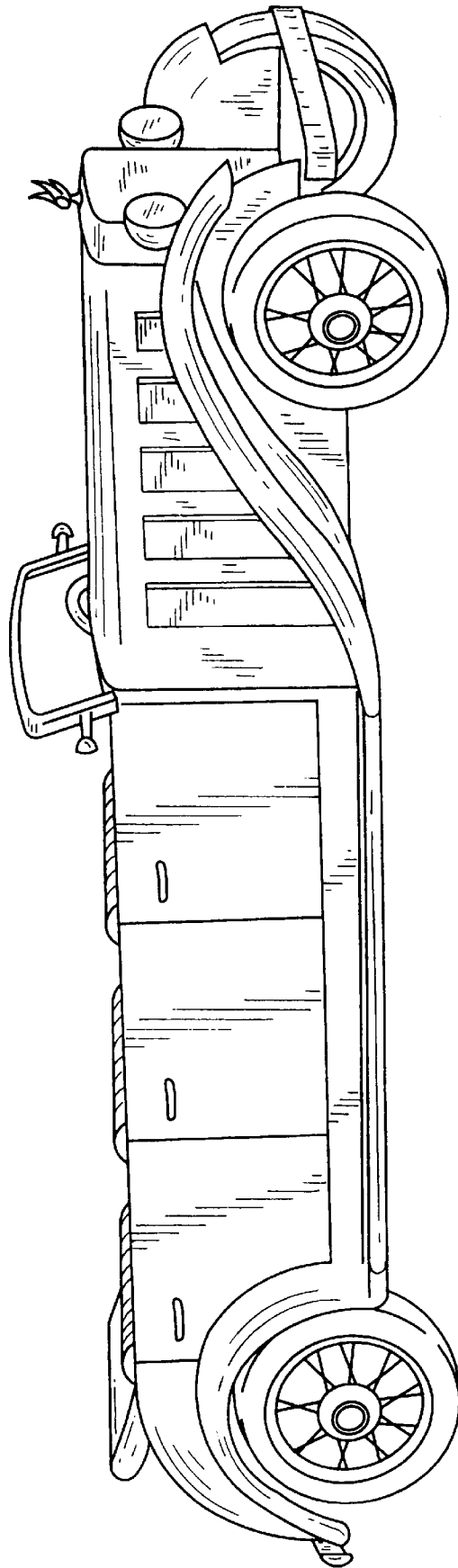

FIG. 1

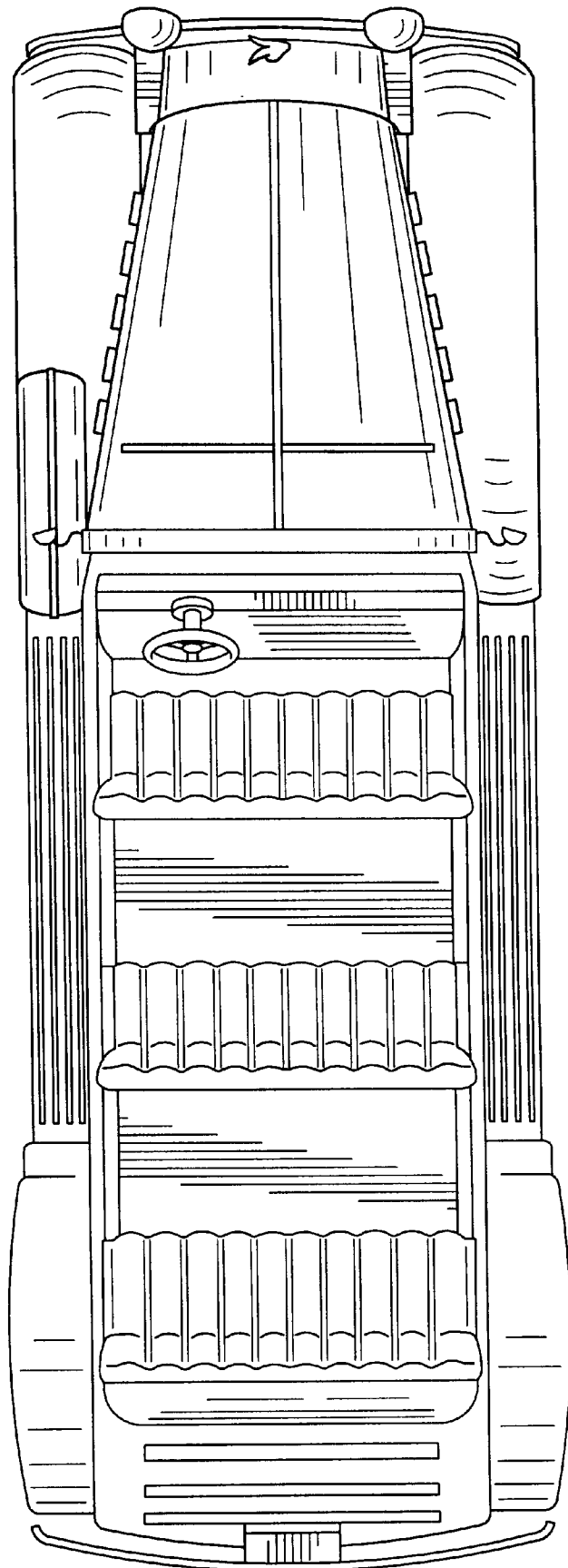

FIG. 2

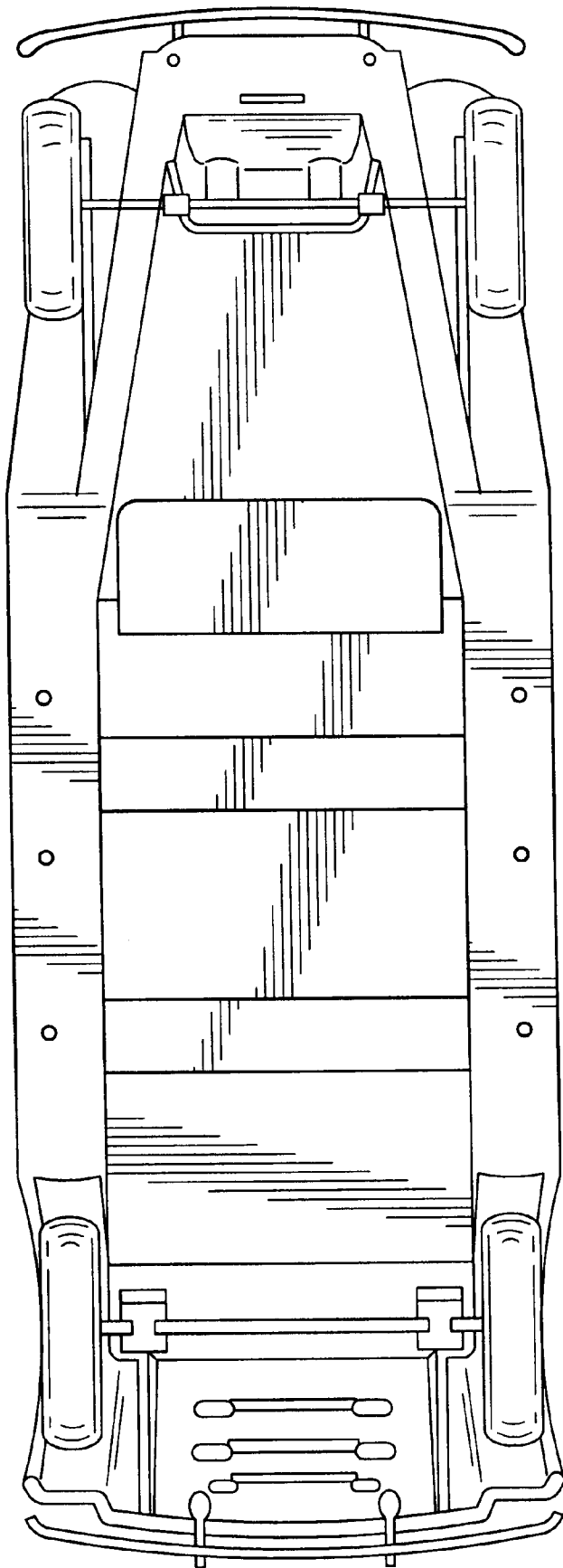

FIG. 3

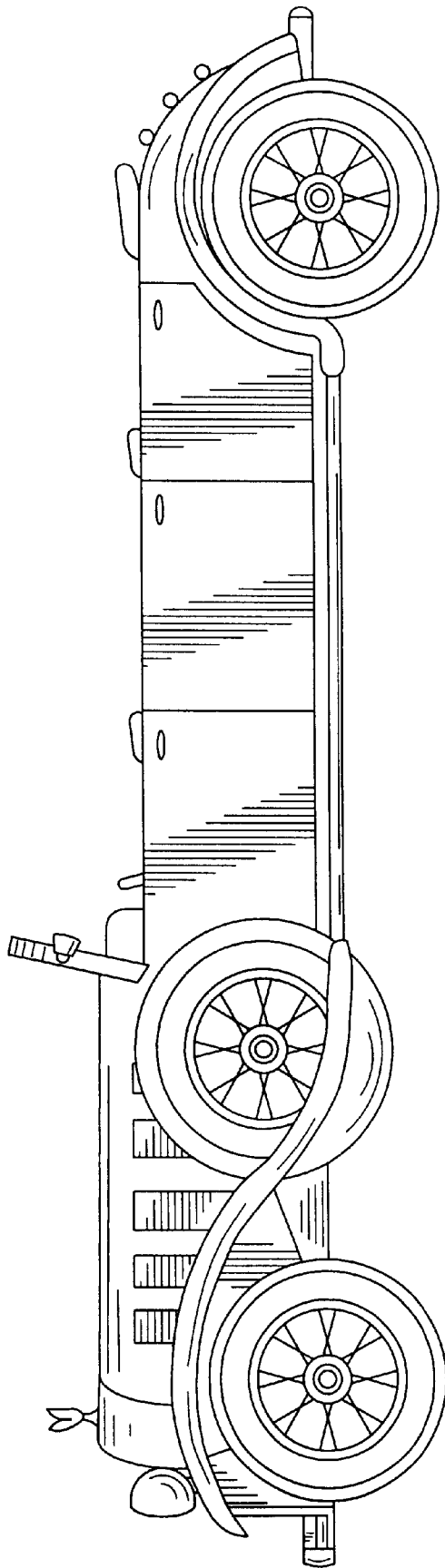

FIG. 4

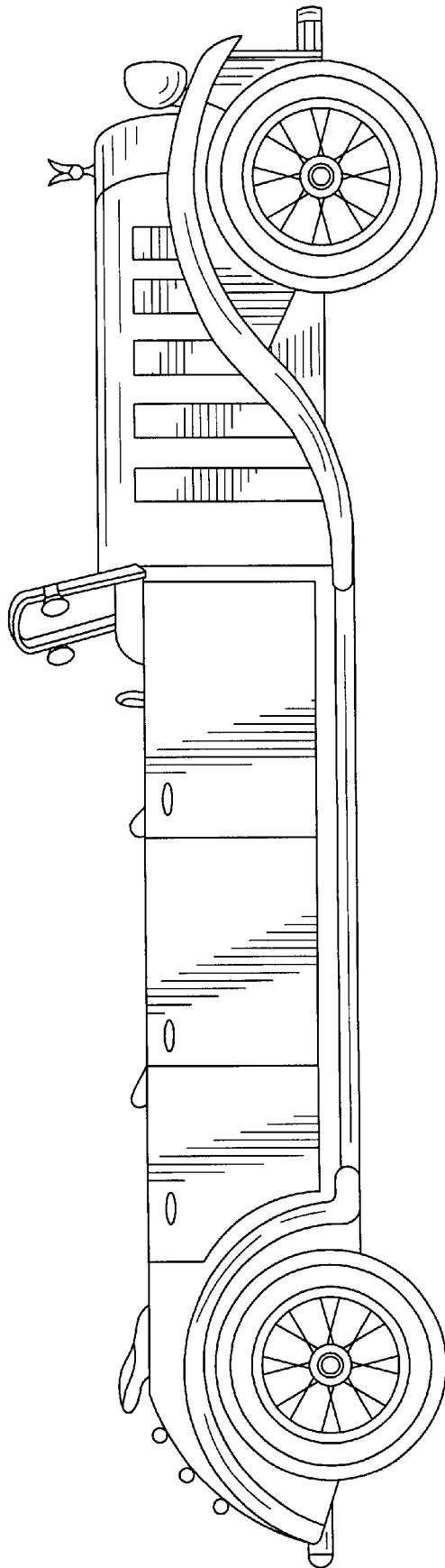

FIG. 5

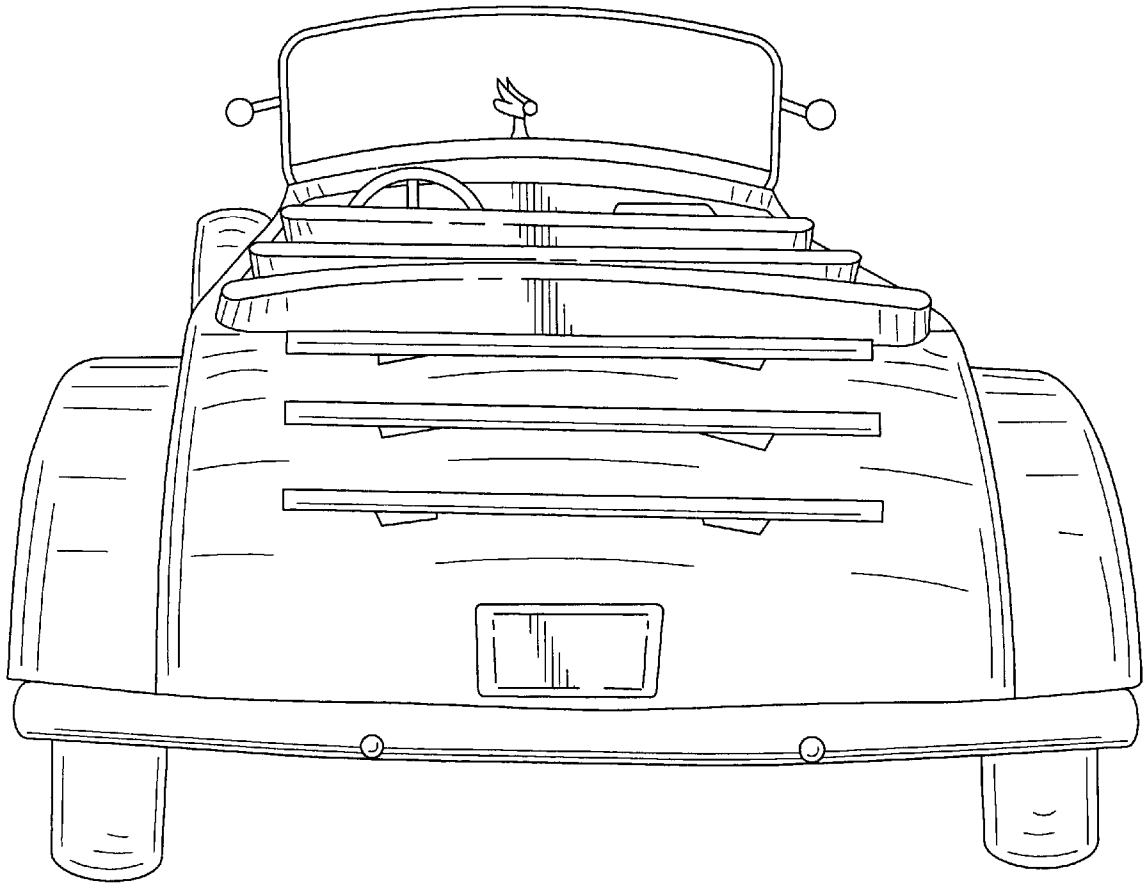

FIG. 6