

Edward Wells' Imp't. in Landaulet Carriage

109981

PATENTED DEC 6 1870

fig 1.

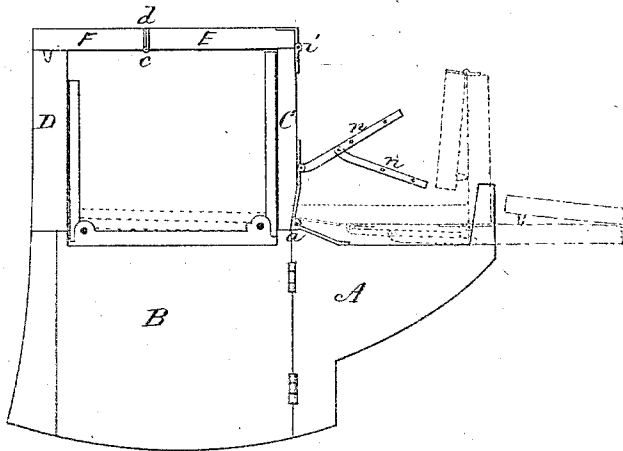
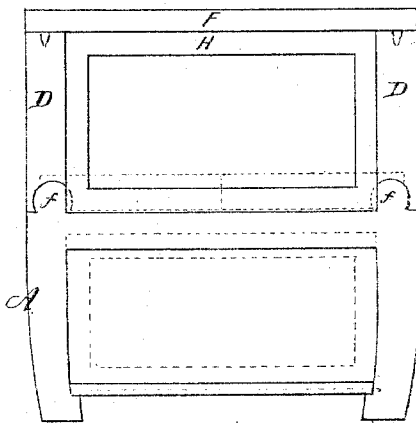

fig 2.



Witnesses

J. H. Hammond
A. J. Roberts

Edward Wells

Inventor

By his Attorney,

John E. Earle

United States Patent Office.

EDWARD WELLS, OF NEW HAVEN, CONNECTICUT.

Letters Patent No. 109,981, dated December 6, 1870.

IMPROVEMENT IN LANDAULET CARRIAGES.

The Schedule referred to in these Letters Patent and making part of the same.

To all whom it may concern:

Be it known that I, EDWARD WELLS, of New Haven, in the county of New Haven and State of Connecticut, have invented a new Improvement in Landaulet Carriages; and I do hereby declare the following, when taken in connection with the accompanying drawing and the letters of reference marked thereon, to be a full, clear, and exact description of the same, and which said drawing constitutes part of this specification, and represents in—

Figure 1, a side view, and

Figure 2, a front view.

This invention relates to an improvement in that class of carriages commonly called "Landaulets;" that is to say, those in which the top, from the center of the door back, folds in like manner as a landau carriage.

The front part has heretofore been removable, that is, taken from the body. This removal is the only objection to this otherwise-desirable style of carriages, as it frequently occurs that, when away with the carriage open, it is desirable to close the top; but this cannot be done, as the front portion is necessarily left where it was taken from the carriage.

To overcome this difficulty is the object of my invention; and

It consists in hinging the posts at the front side of the door, so as to fold down across the front, the sash being constructed so as to drop, the posts covering the sash, and the whole top constructed to double and fold back, so that no part of the carriage is removed, but the whole may be easily adjusted to close the carriage.

A is the body, of usual form, and

B, the door.

The rear door-post C is hinged at *a*, in the usual manner, and the top divided, at the center *d* of the door, into two parts, E F.

The two parts of the top are hinged together at *c*, and the rear part E hinged to the post C at *i*.

The forward portion F is doweled, or otherwise constructed so as to lock onto the front door-post D.

Therefore, detaching the top from the front posts, it may be folded, as denoted in broken lines, fig. 1.

n n are common sash-irons fixed to the post C, to support the bows, for the extension of the rear part of the top, in the usual manner.

The sash H for the front is constructed to drop into a recess in the body, in the usual manner, and the two front door-posts D D, (see fig. 2,) hinged at *f*, will fold down over the sash-opening, as denoted in broken lines.

The shape of the front sash or front end of the carriage may be curved, straight, or any of the usual forms, but so as to permit the dropping of the front or sash. The glass front may be divided into two portions, having a center post between the two portions, extending to the top, and this post constructed to fold over or under the other post, as the case may be.

When the carriage is open, if it is desired to close the top, the posts D D are raised and the top thrown forward, and the parts secured together, as denoted in the drawing, which may be done in a few seconds, and with little or more inconvenience or trouble than is experienced in throwing up the top of an ordinary carriage, and all objections to this style of carriage are overcome.

I claim as my invention—

1. The top, consisting of the two parts E F, hinged together, and the part E hinged to the door-post, so that the said parts and post fold together, substantially in the manner described.

2. In combination with the folding-top E F and the post C, the front posts D D, constructed and arranged to fold down across the front, substantially in the manner set forth.

Witnesses:

EDWARD WELLS.

A. J. TIBBITS,

J. H. SHUMWAY.