

[54] PROPULSION AND DEFLECTOR UNIT FOR WATERCRAFT

[76] Inventor: Neil A. Panyik, 97 W. Main St., Lucas, Ohio 44843

[\*\*] Term: 14 Years

[21] Appl. No.: 210,310

[22] Filed: Jun. 22, 1988

[52] U.S. Cl. .... D12/214; D12/306; D12/317

[58] Field of Search ..... D12/214, 306; 416/247 A, 244 B, 245 A; 415/208.1, 211.2; 440/71, 72, 76, 31; 114/166

[56] References Cited

U.S. PATENT DOCUMENTS

D. 133,078	7/1942	Lee	.....	D12/306
D. 146,659	4/1947	Jaeger	.....	D12/306
D. 292,694	11/1987	Panyik	.....	D12/306
839,672	12/1906	Stub	.	
1,713,446	5/1929	Peterson	.....	416/247 A
2,100,994	11/1937	Cohen	.....	415/211.2
2,544,281	3/1951	Seil	.....	416/247 A
2,900,128	8/1959	Piper, Jr. et al.	.....	415/211.2
3,075,491	1/1963	Hogan	.....	416/247 A
3,173,478	3/1965	Maycen	.....	416/247 A
3,570,436	11/1971	LeVasseur	.	
4,120,615	10/1978	Keem et al.	.....	415/211.2
4,289,487	9/1981	Fattler	.....	440/31

FOREIGN PATENT DOCUMENTS

1122456 9/1956 France .  
682118 2/1965 Italy .

Primary Examiner—Kay H. Chin  
Attorney, Agent, or Firm—Pearne, Gordon, McCoy & Granger

[57] CLAIM

The ornamental design for a propulsion and deflector unit for watercraft, as shown and described.

DESCRIPTION

FIG. 1 is a front elevational view of a propulsion and deflector unit for watercraft showing my new design; FIG. 2 is a sectional view thereof taken along the line 2—2 of FIG. 1;

FIG. 3 is a sectional view similar to FIG. 2 but with deflector vanes in a different position, only the deflector is shown for ease of illustration;

FIG. 4 is a left side perspective view with the vanes in the position of FIG. 3, the right side perspective view being a mirror image of that shown except for the caps on the shaft for the deflector unit;

FIG. 5 is a front elevational view of a second embodiment of the propulsion and deflector unit for watercraft, the fan blades have been omitted for convenience of illustration; and

FIG. 6 is a sectional view of FIG. 5, taken along the line 6—6 of FIG. 5.

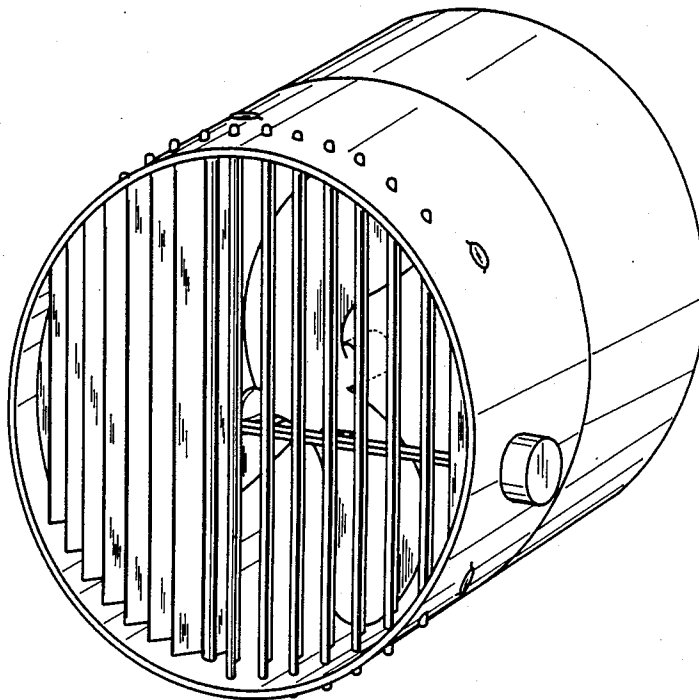

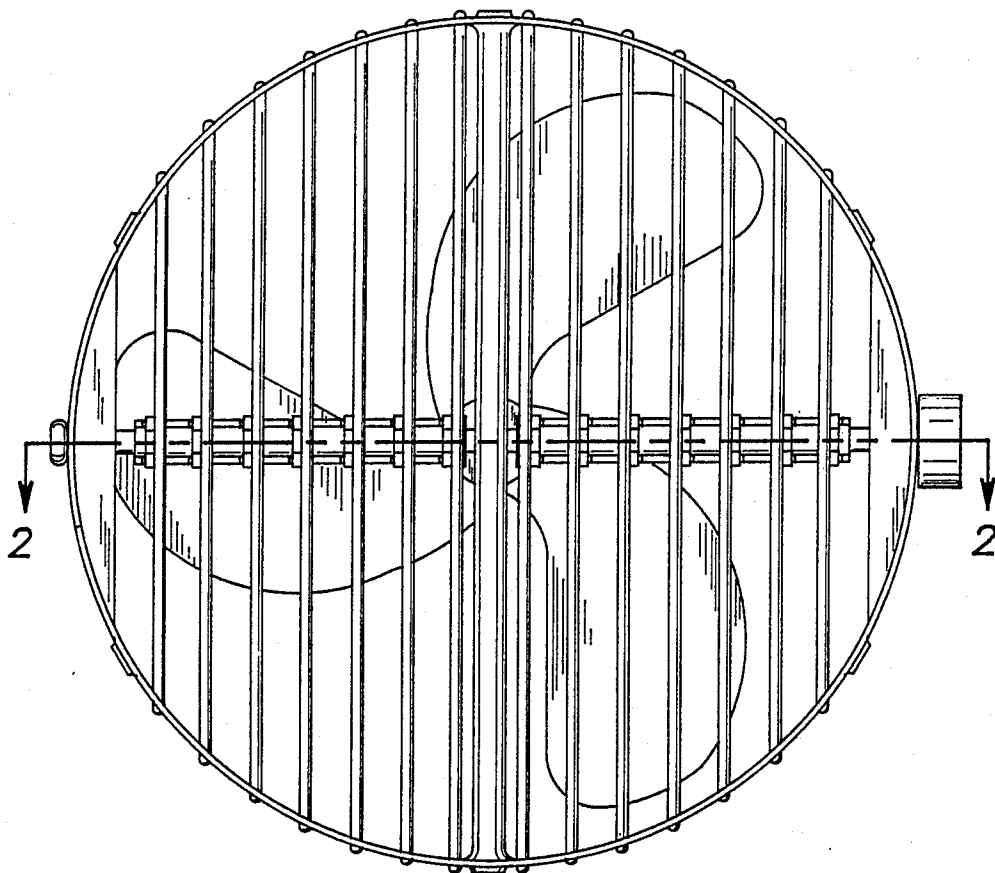

Fig. 1

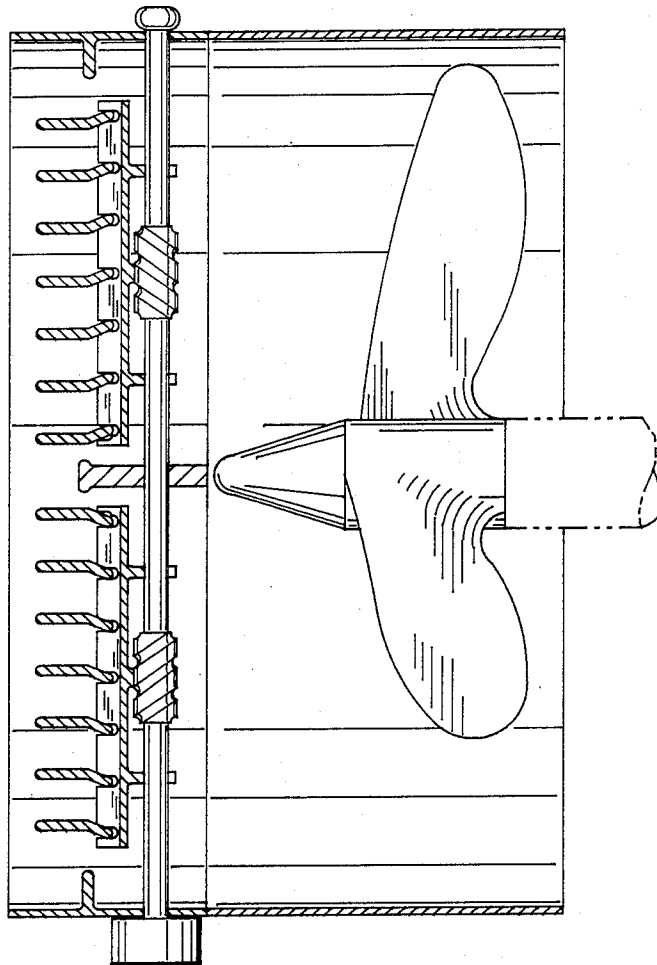

Fig. 2

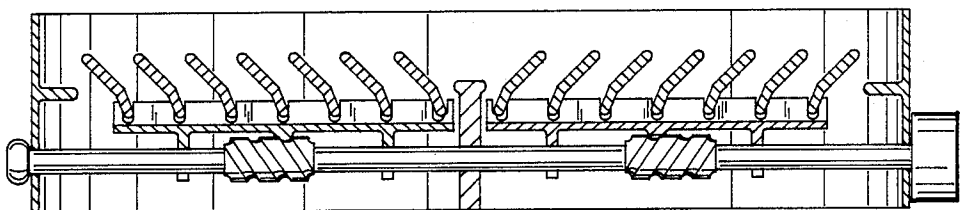

Fig. 3

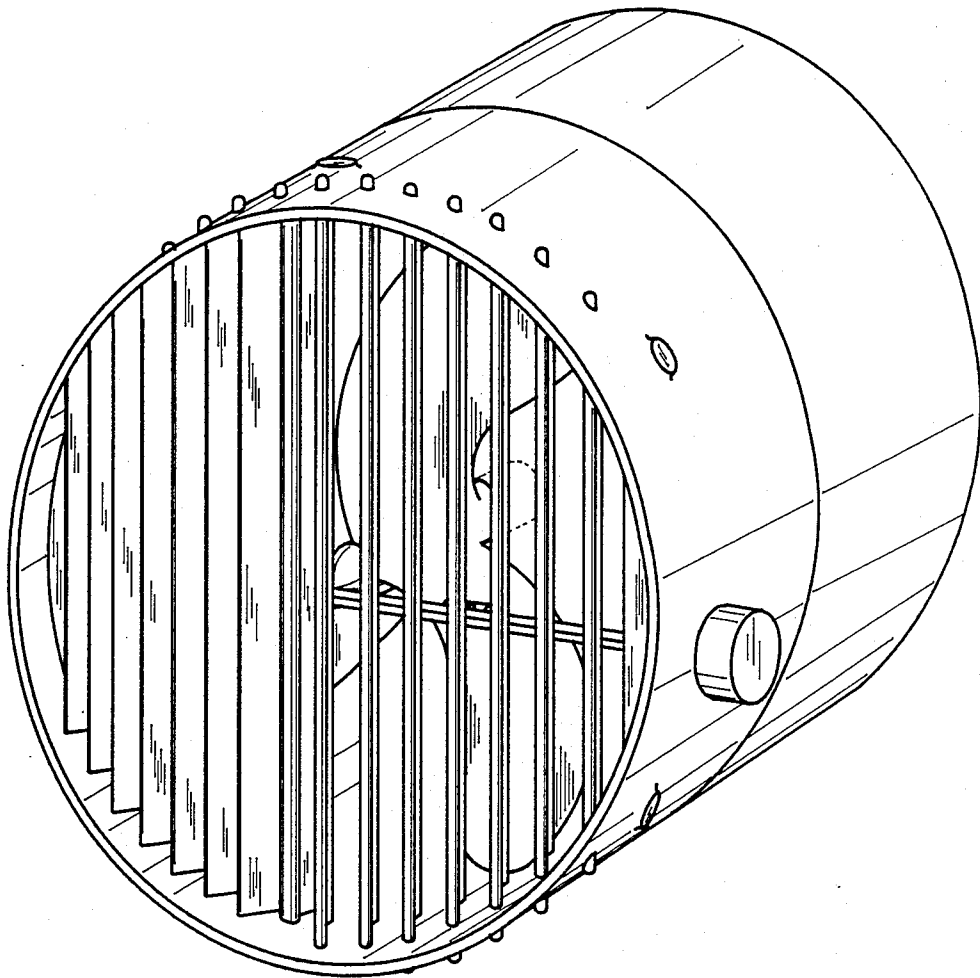

Fig. 4

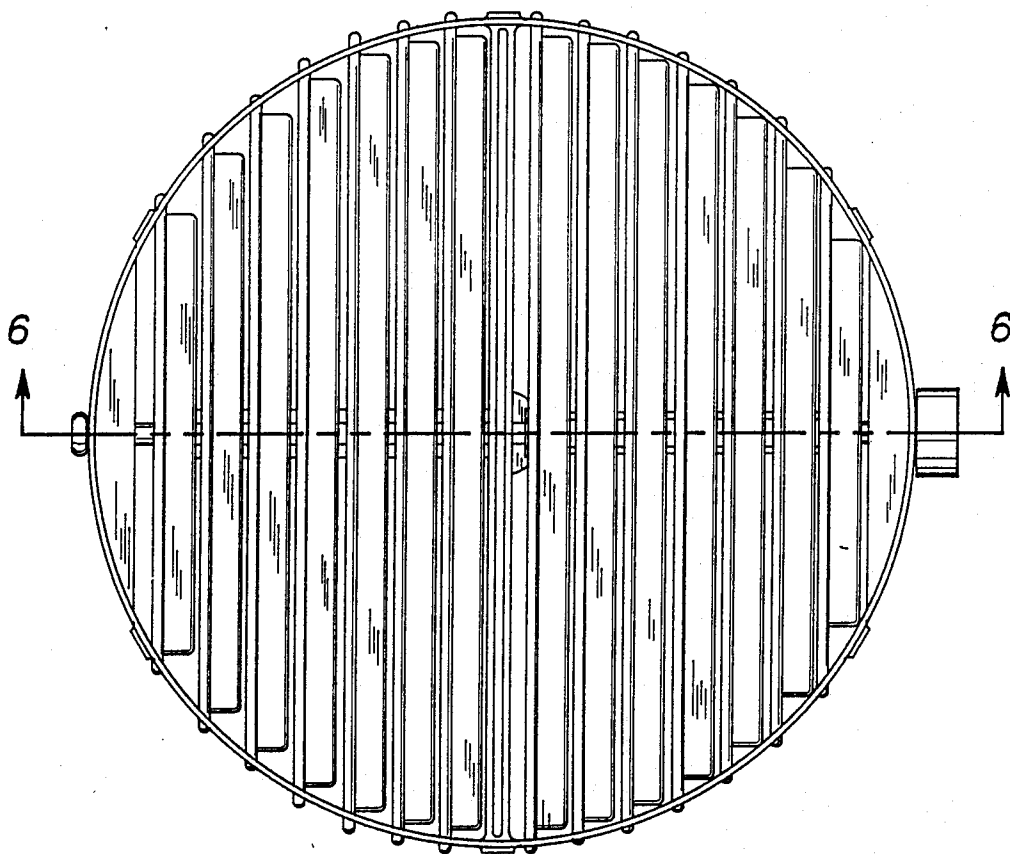

Fig. 5

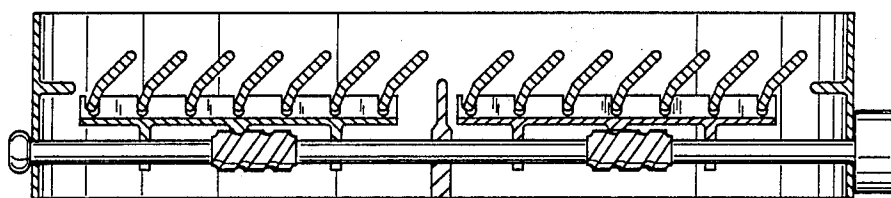

Fig. 6