

R. W. HULL.  
 STEAM PRESSING AND FINISHING IRON.  
 APPLICATION FILED MAR. 11, 1910.

976,571.

Patented Nov. 22, 1910

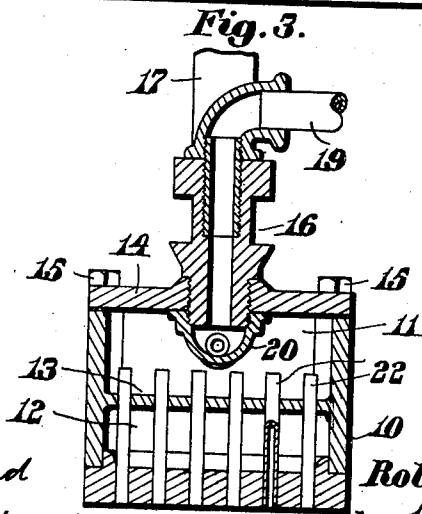
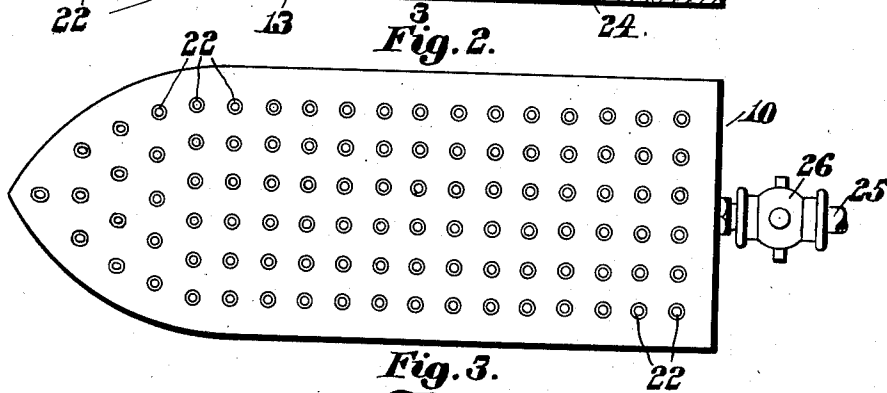
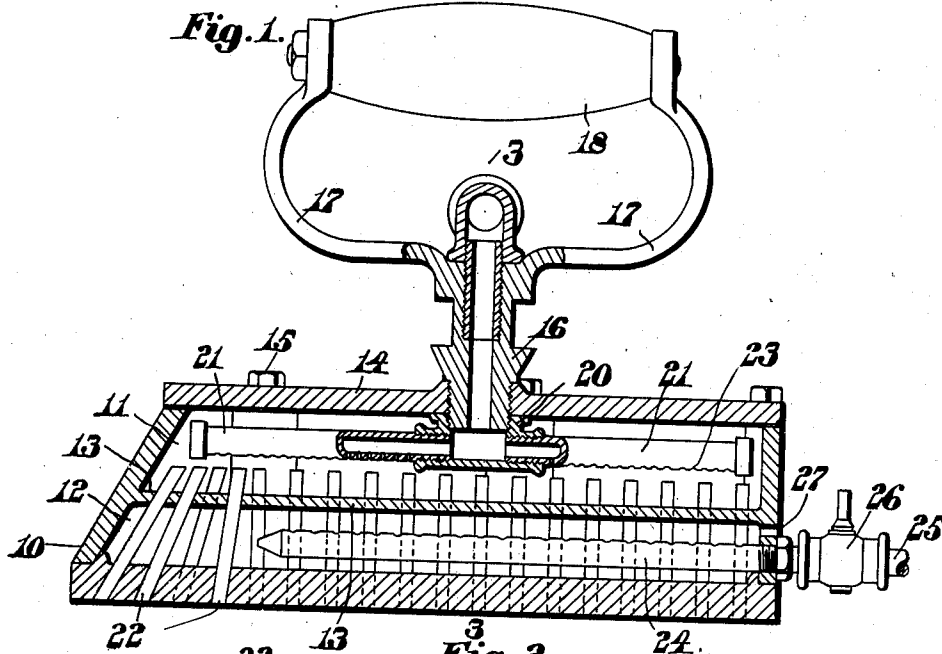

**Witnesses:**  
 Nathan L. Lombard  
 Edna C. Clelland

**Inventor:**  
 Robert W. Hull,  
 by Walter C. Lombard,  
 Atty.

# UNITED STATES PATENT OFFICE.

ROBERT W. HULL, OF HINGHAM, MASSACHUSETTS.

STEAM PRESSING AND FINISHING IRON.

976,571.

Specification of Letters Patent. Patented Nov. 22, 1910.

Application filed March 11, 1910. Serial No. 549,041.

*To all whom it may concern:*

Be it known that I, ROBERT W. HULL, a citizen of the United States of America, and a resident of Hingham, in the county of Plymouth and State of Massachusetts, have invented certain new and useful Improvements in Steam Pressing and Finishing Irons, of which the following is a specification.

10 This invention relates to pressing and finishing irons and has for its object the production of a device of this class which is adapted to dampen cloth or garments made therefrom while the iron is being used  
15 to press and finish the same.

One of the principal objects of the present invention is the production of a chambered iron divided into two compartments one of which is supplied with a water spray while  
20 the other is provided with a means for heating whereby the water in the other compartment is turned into steam and is permitted to pass through tubular members to the operating face of the iron.

25 The invention consists in certain novel features of construction and arrangement of parts which will be readily understood by reference to the description of the drawings and to the claims hereinafter given.

30 Of the drawings: Figure 1 represents a longitudinal vertical section of an iron embodying the features of the present invention, the operating handle for which is shown in elevation. Fig. 2 represents an  
35 inverted plan of the same, and Fig. 3 represents a transverse section of the same, the cutting plane being on line 3-3 on Fig. 1, the handle being broken away.

Similar characters designate like parts  
40 throughout the drawings.

In the drawings, 10 represents a chambered iron divided into two compartments 11 and 12 by means of a horizontal partition 13. The upper compartment is closed by  
45 means of a cover 14 secured to the body portion of the iron by means of a plurality of bolts or screws 15.

Threaded to the cover 14 is a tubular member 16 having secured to its upper end  
50 or formed thereon a yoke 17 carrying a handle 18 by which the iron may be operated. The upper end of the tubular member 16 also has secured thereto a pipe 19 connected to any suitable source of water supply  
55 while the lower end of said tubular

member 16 has threaded thereto a tee 20, the opposite branches of which are secured to perforated pipe members 21 extending longitudinally of the chamber 11.

The lower wall of the iron 10 is provided  
60 with a plurality of open-ended tubes 22 extending upwardly through the partition 13 and into the interior of said chamber 11. The open upper ends of these tubes are so situated as to be out of alinement with the  
65 perforations 23 in the pipe 21 so that no water passing from the perforations 23 may be directed into said tubes 22.

The lower compartment 12 is provided with a perforated gas jet 24 to which gas is  
70 supplied through a pipe 25 provided with a suitable valve 26 by which the supply of gas to the perforated jet 24 may be regulated.

Air is admitted to the chamber 12 through  
75 the perforations 27 in the end wall of the iron 10.

It is obvious that when water is admitted through the perforated pipes 21 the water will pass through the perforations 23 and  
80 impinge against the partition 13 thus causing a fine spray of water throughout the compartment 11.

The intense heat of the partition 13 caused by the flames immediately below said partition rising from the gas jet 24 will turn  
85 this spray of water into steam, portions of which will pass through the tubes 22 to the operating face of the iron 10, thereby sufficiently moistening the cloth or garment being pressed and finished. This dispenses  
90 with the necessity of using a moist cloth spread over the material during the pressing and finishing operation.

Usually in pressing and finishing cloth  
95 material or garments made from cloth another moist cloth is spread over the same and a pressing iron is moved over this moist cloth for the purpose of shrinking the material or garment being operated upon and  
100 when sufficient shrinking has been accomplished the moist cloth is removed and a dry cloth is in turn spread over the material and the pressing and finishing operation continued.  
105

By using this improved iron, the use of both the moist and dry cloth are entirely dispensed with as the steam passing through the open-ended tubes provides sufficient  
110 moisture for the shrinking operation, while

by shutting off the steam the pressing and finishing of the material may be completed with a dry iron.

The gloss that is left on the surface of the material by the use of the dry iron may be removed by again passing said iron over the material with a sufficient quantity of steam passing through the same to effect this result.

It is obvious that the use of this iron saves much time and labor.

It is believed the operation and many advantages of the invention will be fully apparent from the foregoing description.

Having thus described my invention, I claim:

1. In a device of the class described, the combination of a chambered flatiron; a horizontal plate dividing said iron into two compartments; a plurality of open-ended tubes extending through the lower wall of said iron and terminating at points intermediate the plate and the upper wall; means for supplying heat to the lower compartment; and means for supplying a water spray to the upper compartment.

2. In a device of the class described, the combination of a chambered flatiron; a horizontal plate dividing said iron into two compartments; a plurality of open-ended tubes extending through the lower wall of said iron and terminating at points intermediate the plate and the upper wall; a gas jet projecting through the rear wall of said iron for supplying heat to the lower compartment; and means for supplying a water spray to the upper compartment.

3. In a device of the class described, the combination of a chambered flatiron; a horizontal plate dividing said iron into two compartments; a plurality of open-ended tubes extending through the lower wall of said iron and terminating at points intermediate the plate and the upper wall; means for supplying heat to the lower compartment; a perforated tube in said upper com-

partment; and a supply pipe leading to said tube.

4. In a device of the class described, the combination of a chambered flatiron having a cover for said chamber; a horizontal plate dividing said iron into two compartments; a plurality of open-ended tubes extending through the lower wall of said iron and terminating at points intermediate the plate and the upper wall; means for supplying heat to the lower compartment; a tubular member secured to the cover of said iron; a supply inlet connected with one end thereof; and a perforated pipe within the upper compartment communicating with the other end of the tubular member.

5. In a device of the class described, the combination of a chambered flatiron; a horizontal plate dividing said iron into two compartments; a plurality of open-ended tubes extending through the lower wall of said iron and terminating at points intermediate the plate and the upper wall; means for supplying heat to the lower compartment; a handle having a tubular shank secured to the cover of said iron; a supply inlet connected with one end thereof; and a perforated pipe within the upper compartment communicating with the other end of said tubular shank.

6. In a device of the class described, the combination of a chambered flatiron; a horizontal plate dividing said iron into two compartments; a plurality of open-ended tubes extending through the lower wall of said iron and terminating in the upper compartment; means for admitting water to said upper compartment; and means within the lower compartment for heating said plate whereby the water in the upper compartment may be generated into steam.

Signed by me at 4 Post Office Sq., Boston, Mass., this 10th day of March, 1910.

ROBERT W. HULL.

Witnesses:

WALTER E. LOMBARD,  
EDNA C. CLEVELAND.