

Feb. 9, 1960

H. LORANT

2,924,075

HYDRAULIC MOTOR FOR METAL SHAPING PRESSES

Filed Sept. 14, 1953

3 Sheets-Sheet 1

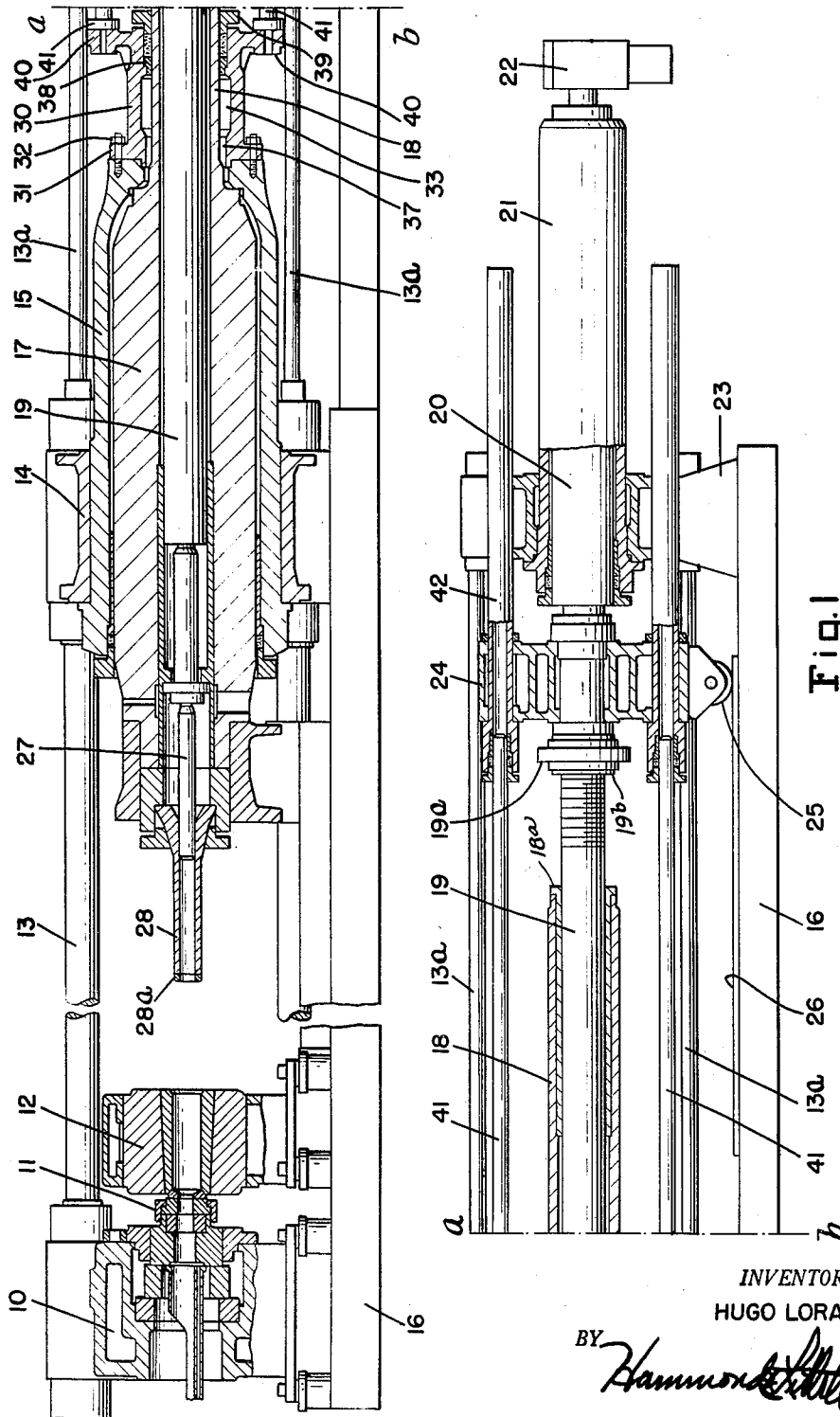

Fig. 1

INVENTOR.  
HUGO LORANT

BY *Hammond & Co.*  
ATTORNEYS

Feb. 9, 1960

H. LORANT

2,924,075

HYDRAULIC MOTOR FOR METAL SHAPING PRESSES

Filed Sept. 14, 1953

3 Sheets-Sheet 2

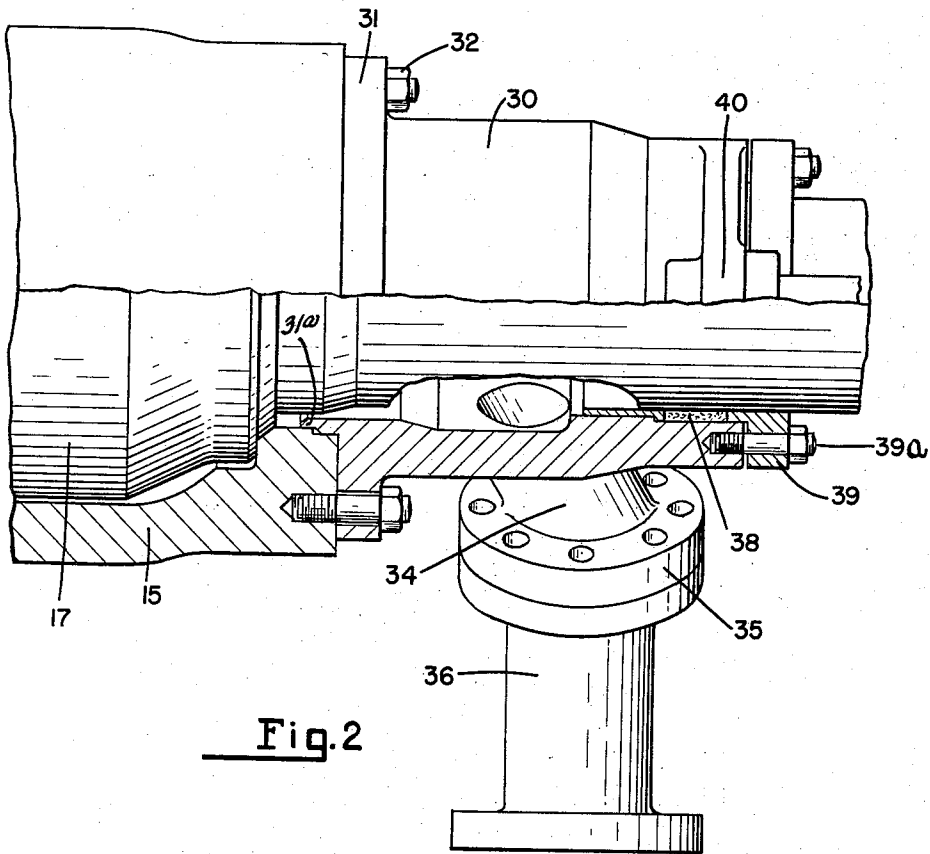

INVENTOR.  
HUGO LORANT

BY  
*Hammond & Killet*  
ATTORNEYS

Feb. 9, 1960

H. LORANT

2,924,075

HYDRAULIC MOTOR FOR METAL SHAPING PRESSES

Filed Sept. 14, 1953

3 Sheets-Sheet 3

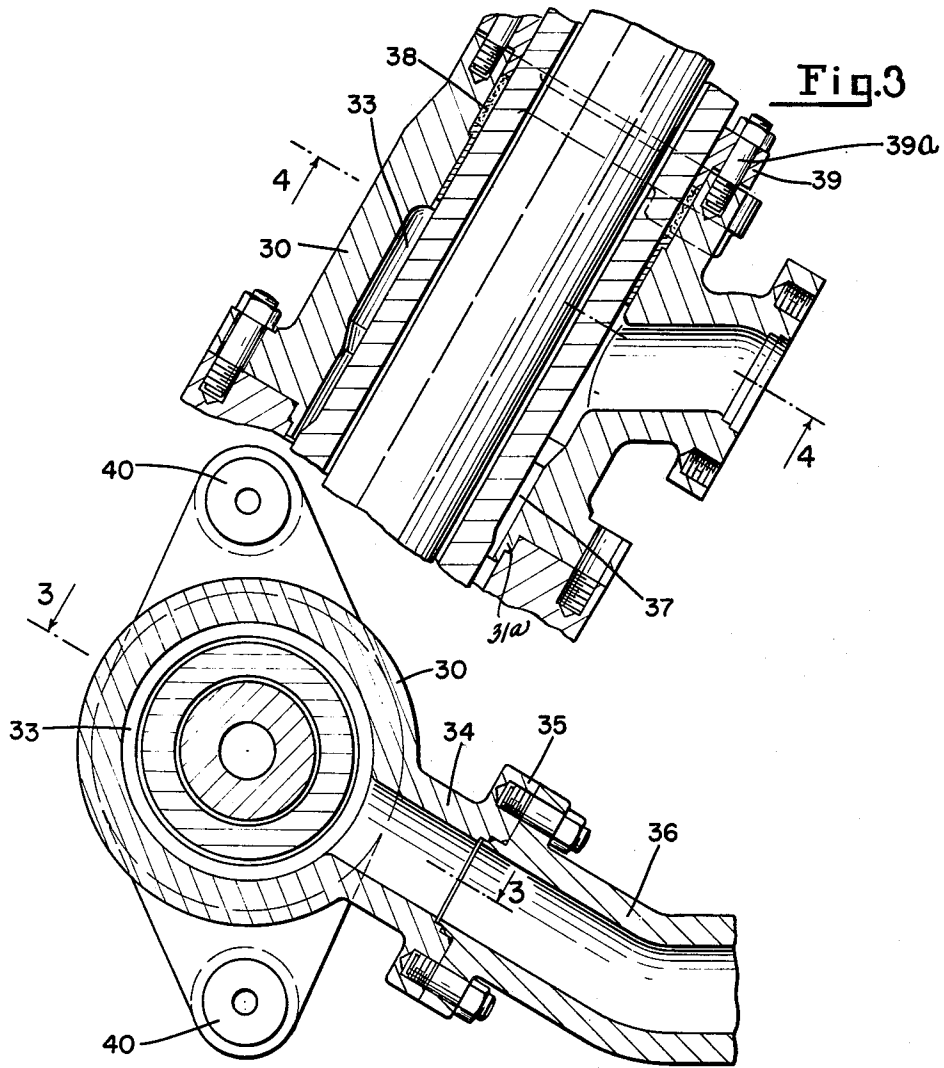

Fig. 4

INVENTOR.  
HUGO LORANT

BY *Hammond & Little*  
ATTORNEYS

1

2,924,075

## HYDRAULIC MOTOR FOR METAL SHAPING PRESSES

Hugo Lorant, New York, N.Y.

Application September 14, 1953, Serial No. 379,919

3 Claims. (Cl. 60—97)

This invention relates to an improvement in hydraulic motors or drives for presses for hydraulic extrusion, forging, stamping and the like, particularly for metals such as copper, ferrous metals, aluminum and the like, of the type in which the main ram or piston has a passage therethrough and a working tool such as a piercer or mandrel is operated through said passage.

The invention will be described with particular reference to a hydraulic extrusion press and from this description its application to forging, stamping and similar presses will be readily apparent.

In extrusion presses of this type the piercing or mandrel operating mechanism extends rearwardly from the main cylinder, and the main ram or piston is often provided with a rearwardly projecting hollow cylindrical extension through which the mandrel or other tool operating mechanism passes, so that normally it is not possible to introduce the pressure fluid into the main cylinder from the rear end thereof and means must be provided for introducing the pressure fluid into the main cylinder and behind the piston, through the side wall of the cylinder. This requires a thickened section in the side wall of the main cylinder, to which the pressure fluid inlet pipes may be attached, and requires special forging or casting technique to produce large cylinders with such thickened section in the side walls thereof. These thickened sections cause uneven stresses during the casting or forging operation, and in the use of the cylinders cracks often develop adjacent the thickened sections, which require discarding the main cylinder and the provision of a new main cylinder.

In extrusion and other presses which are not provided with working tools, such as piercers, mandrels or the like working through the main ram, it is customary to provide an opening in the rear end of the main cylinder approximately on the centerline thereof through which the pressure fluid is introduced behind the main ram on the pressure stroke and expelled from the cylinder on the return stroke and to provide main cylinders having substantially uniform wall thickness throughout. Such cylinders do not develop cracks with as much frequency as cylinders with un-uniform wall thickness and side inlets for pressure fluid as described above.

Extrusion presses which are not provided with working tools operating through the main ram are provided with solid main rams and if such an extrusion press is to be converted into a press for piercing billets and extruding hollow forms it is necessary to provide both a new main cylinder and a new main ram as well as the tool operating mechanism.

It is the object of this invention to provide an improvement which will overcome the above-named objections to existing presses, and provide, for example, an extrusion press with working tools operating through the main ram, which is of simpler design, more economical construction and subject to less likelihood of cylinder breakage than prior extrusion presses of this type.

Another object of this invention is to provide a press

2

with means to operate a working tool such as a piercing tool, mandrel or the like, through the main ram in which the main cylinder has walls of substantially uniform thickness and in which the pressure fluid is introduced into the main cylinder at the rear thereof and substantially uniformly around the centerline thereof.

Another object of this invention is to provide an improvement in presses which will permit conversion of existing presses with solid main rams into presses with hollow rams and means to operate a working tool therethrough without the necessity of providing a new main cylinder for the press.

Another object of this invention is to provide a press of the type described in which the main ram has a passage therethrough and means to operate a working tool through said passage, having a main cylinder of simplified design and substantially uniform wall thickness whereby the fabrication of said main cylinder is simplified and any tendency of the main cylinder to crack, due to un-uniform wall thickness and un-uniform stresses is reduced.

Another object of my invention is to provide a cylindrical extension or connector for the main cylinder of a press of the type in which a working tool is operated through the main ram of the press which extension may be connected to the rear of the main cylinder and surround the rearward projection of the main ram, and to provide means to introduce pressure fluid through said extension and into the rear of the main cylinder approximately uniformly around the centerline of the main cylinder.

Various other objects and advantages of my invention will be made apparent as this description proceeds.

Referring now to the drawings which illustrate one form of embodiment of my invention as applied to a hydraulic extrusion press:

Fig. 1 is a simplified drawing in two parts showing a longitudinal cross-sectional view of an extrusion press, with the improvement of my invention applied thereto.

Fig. 2 is a detailed view of the cylindrical extension or connector providing the pressure fluid inlet to the main cylinder.

Fig. 3 is a sectional view of the connector of Fig. 2 taken on the line 3—3 of Fig. 4.

Fig. 4 is a cross-sectional view on the line 4—4 of Fig. 3.

In the embodiment of the invention chosen for the purpose of illustration, the upper portion of Fig. 1 shows in simplified outline the die, billet container, main cylinder, and part of the main ram of an extrusion press for extruding tubes and other shapes, and the lower portion of Fig. 1 shows the rearward extension of the same press. This simplified view of the press has been broken away along the line *a—b* to facilitate the illustration of the entire press on one sheet of drawing.

Referring in detail to this figure, a platen or cross-head 10 mounted on the bed plate 16 supports a removable die 11 against which the movable billet container 12 is adapted to seat during an extrusion operation. The platen 10 is connected by columns or tie rods 13 to the main cylinder cross-head 14 in which the main cylinder 15 is secured. The platen 10 and main cylinder cross-head 14 are rigidly mounted on bed plate 16, and the billet container 12 is movably mounted with reference to the platen 10. A main ram or piston 17 operates inside the main cylinder 15 and is provided with a rearwardly extending hollow cylindrical projection 18 through which the secondary tool operating ram or stem 19 moves. The secondary tool operating ram 19 is adjustable through the mandrel adjustment assembly 19a and is controlled by a piston 20 operating in the tool operating cylinder 21 which receives pressure fluid through the valve con-

nection 22. Tool operating cylinder 21 is supported from the bed plate structure 16 by means of a support 23 to which it is rigidly connected and the horizontal thrust is taken by tie rods 13a connected to the main tie rods 13 adjacent the cross-head 14. The piston 20 and other operating mechanism for the secondary tool operating ram 19 is supported on a cross-head 24 having wheels 25 which move along a track 26 mounted on the bed plate 16. The forward end of the secondary ram 19 carries a mandrel and piercing tool 27 which is adapted to be projected through the hollow pressing stem 28 so that by operation of the piston 20 in the cylinder 21 the piercing mandrel 27 may be caused to pierce the billet and then take a position in the mouth of the die 11 so as to permit a hollow tube to be extruded therearound when the pressing stem 28 is advanced by movement of the main ram 17. When desired, or necessary for the extrusion, the pressure of the cylinder 21 may be added to the pressure of the main cylinder 15 by moving the abutment 19b of the mandrel adjusting assembly 19a against the abutment 18a on the hollow projection 18 of the main ram 17. When in this position further introduction of hydraulic fluid into the cylinder 21 will add the pressure in the cylinder 21 to the pressure in the cylinder 15 for moving the ram 17 forward so that the total pressure which can be exerted on the metal being shaped is the combined pressure of the cylinders 15 and 21. All of these parts are usual parts of an extrusion press for extruding hollow tubes.

In the normal construction of an extrusion press of this type the pressure fluid is introduced into the main cylinder through the side walls of the cylinder at a point adjacent to the rear end of the main cylinder and just behind the end of main ram. This construction, however, requires a thickening of side walls of the main cylinder at the point where the pressure fluid inlet pipes are attached so that if the main cylinder is produced by casting, a thickened ring or an elbow or joint projection must be provided for connection with the pressure fluid line from the accumulators, and if a forged cylinder is to be produced a similar wide projection or thickened section must be provided for connection with the inlet for the pressure fluid. In either event, the manufacture of the main cylinder becomes more complicated and due to the uneven wall thickness brought about by this projection or thickened portion, cracking of the cylinder due to un-uniform construction and un-uniform stresses is more likely to take place at this point.

Where the press is not provided with a hollow main ram and means to operate a working tool through the said hollow main ram, it is possible to make connections for the inlet of the pressure fluid into the main cylinder along the centerline of the main cylinder at the rear end thereof. In this construction the main cylinder may be provided with a wall of substantially uniform thickness and the manufacture of the cylinder is simplified and there is less risk of cracking of the main cylinder in service.

In the extrusion press, according to my invention, I have provided a pressure inlet connector 30 for the main cylinder which is connected with the rear of the main cylinder by means of flange 31 and bolts 32 and provides a cylindrical chamber 33 which surrounds the rearward extension 18 of the main ram 17. An integral annular projection 31a on the connector 30 projects into the opening in the rear of the main cylinder and bears against the inside walls of the opening in the rear of the main cylinder. The cylindrical connection 30 is provided with an integral nipple 34 extending at an angle of approximately 75° to the centerline of the connector, which has a flange 35 by which it can be connected to an elbow 36 to which the pressure fluid line from the accumulators may be connected so that the pressure fluid may be introduced through the elbow 36 and nipple 34 into the passage 33 where it passes through the passage

37 surrounding the extension 18 and into the rear of the main cylinder 15 behind the main ram 17 to move the ram 17 forward on the extrusion stroke of the press.

Suitable packing 38 is inserted between the rearward portion of connector 30 and the rearward extension 18 of the main ram, a cylindrical bushing 39 is secured by bolts 39a to the rear of the connector 30 so that the packing may be kept in fluid tight contact with the extension 18 and prevent leakage of the pressure fluid from the rear of connector 30. Connector 30 is also provided with outwardly extending ears 40 at the rear thereof to which the stationary piercer return rams or elements 41 for the tool controlling mechanism are connected. The return rams 41 are hollow and the pressure fluid for returning the piercer tool operating mechanism to its rearward or withdrawn position is introduced through the ears 40 and into the hollow stationary rams 41 and flows from the rearward end of the hollow rams 41 into the movable piercer or tool return cylinders or elements 42, forcing these cylinders to travel rearward from the tool advancing position to move the piston 20 back into the cylinder 21 and retract the mandrel 27 from its position in the mouth of the die.

As illustrated in the lower section of Fig. 1, the tool operating mechanism is in its extreme rearward or retracted position. To advance the tool operating mechanism 19, 20, etc., and the mandrel 27, or any other tool which may be connected thereto, into the billet container to pierce a billet and into the mouth of the die to act as a mandrel, pressure fluid is admitted to the valve 22 and into the rear of the cylinder 21 moving the piston 20 and the mandrel operating stem 19 forward. For example, to pierce a billet within the billet container 12 and then position the mandrel 27 in the mouth of the die 11.

To then extrude the billet into a hollow tube pressure fluid is introduced through the elbow 36 and nipple 34 into connector 30, chamber 33 and passage 37, into the rear of the main cylinder 15, so that it moves the main ram 17 forward in the cylinder 15 to push the extrusion stem 28 against the rear of the billet to cause the billet to flow through the die opening. A removable ring 28a is mounted on the forward end of the extrusion stem 28 to protect the stem against contact with the hot billet and permit easy retraction of the press stem 28 when the extrusion is finished. If desired, the pressure of the cylinder 21 may be added to the pressure available in the main cylinder to complete the extrusion in the manner previously described.

At the end of the extrusion stroke the main ram is retracted by pistons operating in return cylinders at each side of the main ram. These cylinders are not shown in the present drawings, but are of the usual construction used in extrusion presses.

By the use of the separate connector 30 at the rear end of the main cylinder it is possible to introduce the pressure fluid into the rear of the main cylinder and on the return stroke to expel it therefrom without providing a thickened side wall projection on the main cylinder, and to realize many advantages in the construction and operation of such a press. The thickness of the side wall of the main cylinder is substantially uniform in any plane at right angles to the axis of the cylinder. It is also possible by the use of such a connector and other parts to readily convert an extrusion press for solid extrusion into a press for hollow extrusion without changing the main cylinder by merely removing the pressure fluid inlet connection into the rear of the main cylinder of a press for solid extrusion, inserting a new hollow main ram, installing the necessary tool or piercer and mandrel operating cylinders, etc., and using a connector such as connector 30, surrounding the rearward projection of the new main ram and connecting with the rear of the old main cylinder for the introduction and outflow of the pressure fluid to and from the main cylinder.

5

While I have illustrated and described a preferred embodiment of my invention when used particularly as the hydraulic motor of an extrusion press, it will be understood that various modifications and changes may be made therein and the construction used in other presses within the spirit of my invention and the scope of the following claims.

I claim:

1. In a hydraulic motor, a main cylinder having a substantially imperforate side wall of substantially uniform thickness in any plane at right angles to the axis of the main cylinder, said main cylinder including an integral rear wall curving inwardly from the side wall of said main cylinder and having an opening therein concentric with the axis of said main cylinder, a hollow main ram in said main cylinder having a rearward hollow cylindrical projection of reduced diameter thereon extending through the opening in said rear wall of said cylinder and spaced from the walls of said opening, said rear wall of the main cylinder extending inwardly substantially to said rearward cylindrical projection of reduced diameter on said main ram and taking the thrust of pressure fluid between the main ram and the rear wall of said main cylinder on a pressure stroke of said motor, a separate substantially cylindrical connector on the end of said main cylinder connected to the rear wall of said main cylinder and surrounding and spaced from said rearward cylindrical projection on said main ram and thereby providing an annular passage around said projection for the introduction of the pressure fluid through said opening into the main cylinder, said connector having an opening at each of its ends and an opening in its side, means to secure the connector to the rear wall of the main cylinder, means to seal the connector against the escape of pressure fluid at the rear thereof between said connector and said rearward projection on the main ram, means to connect a pressure fluid inlet pipe to said opening in the side of said connector, and a secondary ram operative in the hollow of said main ram and its projection.

2. In a hydraulic motor, a main cylinder having a substantially imperforate side wall of substantially uniform thickness in any plane at right angles to the axis of the main cylinder, said main cylinder including an integral rear wall curving inwardly from the side wall of said main cylinder and having an opening therein concentric with the axis of said main cylinder, a hollow main ram having a rearward hollow cylindrical projection of reduced diameter extending through the opening in said rear wall of said cylinder and spaced from the walls of said opening, said rear wall extending inwardly substantially to said rearward cylindrical projection of reduced diameter, a separate cylindrical connector on the end of said main cylinder surrounding and spaced from the rearward projection of said main ram and substantially equidistant from the centerline of the main cylinder and thereby providing an annular passage

6

around said projection for the introduction of pressure fluid into the main cylinder, said connector having an opening at each of its ends and an opening in its side, said side opening including a branch extending from the side of said connector at an angle of approximately 75° to the centerline of the main cylinder and sloping in the direction of the forward movement of the hollow main ram, means to secure the connector to the rear wall of said main cylinder, means to seal the connector against the escape of pressure fluid between the connector and the rearward projection of the ram, means to connect a pressure fluid inlet pipe to said branch extending from the side of said connector, and a secondary ram operative in the hollow of said main ram and its projection.

3. In a hydraulic motor, a main cylinder and a hollow main ram in said main cylinder having a rearward hollow cylindrical projection of reduced diameter extending through the rear wall of said main cylinder through which a secondary ram is operated, said main cylinder being of substantially uniform wall thickness in any plane at right angles to the axis of the main cylinder, having a cylindrical opening in the rear thereof concentric with the axis of the main cylinder surrounding and spaced from said rearward hollow cylindrical projection, means to conduct pressure fluid into said opening in said main cylinder behind the main ram to operate the main ram in said main cylinder comprising a separate substantially cylindrical connector on the end of said main cylinder surrounding and spaced from said rearward hollow cylindrical projection and providing a passage for the introduction of pressure fluid into the main cylinder, means to secure said connector to the rear of said main cylinder, an opening in the side of said connector, a seal between the rear of said connector and said rearward hollow cylindrical projection, a secondary operating cylinder and piston for operating said secondary ram through said hollow main ram and hollow cylindrical projection, return means for said secondary ram consisting of hollow stationary elements and movable cylindrical elements, hollow ears on said connector and means to secure said stationary elements of the return means to said ears, whereby pressure fluid for operating said return means can be introduced through said ears into said hollow stationary elements.

#### References Cited in the file of this patent

##### UNITED STATES PATENTS

501,426	Kampf	July 11, 1893
502,844	Aiken	Aug. 8, 1893
861,194	Schwieger	July 23, 1907
1,470,381	Lamb	Oct. 9, 1923
2,258,464	Moody	Oct. 7, 1941
2,337,804	Dempsey	Dec. 28, 1943
2,713,941	Schuler	July 26, 1955