

(12) INTERNATIONAL APPLICATION PUBLISHED UNDER THE PATENT COOPERATION TREATY (PCT)

(19) World Intellectual Property Organization
International Bureau



(43) International Publication Date
18 February 2010 (18.02.2010)

PCT

(10) International Publication Number
WO 2010/018552 A1

- (51) **International Patent Classification:**
A41D 19/015 (2006.01) A63B 71/14 (2006.01)
- (21) **International Application Number:**
PCT/IB2009/053574
- (22) **International Filing Date:**
13 August 2009 (13.08.2009)
- (25) **Filing Language:** English
- (26) **Publication Language:** English
- (30) **Priority Data:**
TV2008A000107 13 August 2008 (13.08.2008) IT
- (71) **Applicant (for all designated States except US):**
ALPINESTARS RESEARCH SRL [IT/IT]; Via A. De Gasperi, 54, I-31010 Coste di Maser (Treviso) (IT).
- (72) **Inventor; and**
- (75) **Inventor/Applicant (for US only): MAZZAROLO, Giovanni** [IT/IT]; Via Marosticana 33, I-31010 Coste di Maser (Treviso) (IT).
- (74) **Agents: DRAGOTTI, Gianfranco et al.;** Via Paris Bordone, 9, I-31100 Treviso (IT).
- (81) **Designated States (unless otherwise indicated, for every kind of national protection available):** AE, AG, AL, AM, AO, AT, AU, AZ, BA, BB, BG, BH, BR, BW, BY, BZ, CA, CH, CL, CN, CO, CR, CU, CZ, DE, DK, DM, DO,

DZ, EC, EE, EG, ES, FI, GB, GD, GE, GH, GM, GT, HN, HR, HU, ID, IL, IN, IS, JP, KE, KG, KM, KN, KP, KR, KZ, LA, LC, LK, LR, LS, LT, LU, LY, MA, MD, ME, MG, MK, MN, MW, MX, MY, MZ, NA, NG, NI, NO, NZ, OM, PE, PG, PH, PL, PT, RO, RS, RU, SC, SD, SE, SG, SK, SL, SM, ST, SV, SY, TJ, TM, TN, TR, TT, TZ, UA, UG, US, UZ, VC, VN, ZA, ZM, ZW.

(84) **Designated States (unless otherwise indicated, for every kind of regional protection available):** ARIPO (BW, GH, GM, KE, LS, MW, MZ, NA, SD, SL, SZ, TZ, UG, ZM, ZW), Eurasian (AM, AZ, BY, KG, KZ, MD, RU, TJ, TM), European (AT, BE, BG, CH, CY, CZ, DE, DK, EE, ES, FI, FR, GB, GR, HR, HU, IE, IS, IT, LT, LU, LV, MC, MK, MT, NL, NO, PL, PT, RO, SE, SI, SK, SM, TR), OAPI (BF, BJ, CF, CG, CI, CM, GA, GN, GQ, GW, ML, MR, NE, SN, TD, TG).

Declarations under Rule 4.17:

— of inventorship (Rule 4.17(iv))

Published:

— with international search report (Art. 21(3))

— before the expiration of the time limit for amending the claims and to be republished in the event of receipt of amendments (Rule 48.2(h))

(54) **Title:** GLOVE STRUCTURE, IN PARTICULAR FOR MOTORCYCLING SECTOR

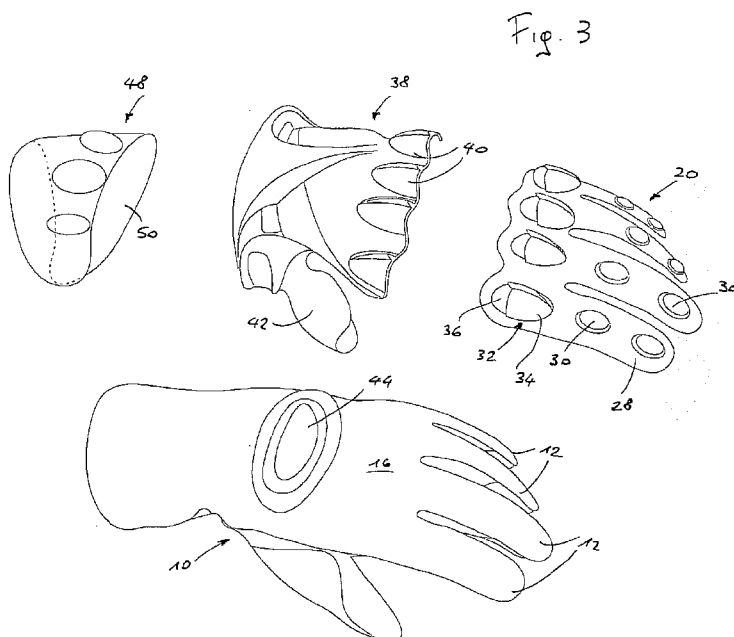

(57) **Abstract:** A motorcycle glove structure comprises a system for protecting the fingers, made with a double layer of plastic, the first layer (26) of which is injected directly and coextensively onto a flat part made of leather or similar material or fabric (24). The second layer (28) made of impact and abrasion resistant plastic is injection-moulded over the first layer and preferably has projections (30) opposite the minor knuckles. The structure also comprises a shield (38) which is made of impact and abrasion resistant plastic applied to the back of the hand and which has at the front portions (40) shaped so as to mate with projections (32) formed at the end of said second layer (28) for protecting the fingers, said co-operating projections being positioned opposite the major knuckles of the hand. The shield (38) has, co-operating therewith, a sleeve part (48) which is fixed to the glove beyond the wrist line and is provided with a rib (54) against which the rear end of said shield comes into contact when a force is applied in the direction from the fingers towards the wrist.

WO 2010/018552 A1

"Glove structure, in particular for the motorcycling sector "

The present invention relates to a glove structure and more specifically to a glove structure for motorcycle riding.

5 It is known that motorcycle riding gloves, in addition to providing protection against bad weather, must also be able to provide specific protection in the event of falls and accidents.

10 In such cases, the rider is projected from the saddle and, in view of the speed of the motorcycle at the moment of the accident and/or the fall, may slide over a distance of several metres on the road surface - and therefore on asphalt, grit or, in the best of circumstances, grass - suffering not insignificant injuries to the fingers, palm/back of the hands and/or the articulation between the arm and the wrist.

15 It may also happen that, during a fall, the rider's hand is trapped underneath the motorcycle so that injury, especially due to abrasion, is greatly worsened by the weight of the motorcycle pressing on the hand.

At the same time, the glove structure must not only be comfortable, but must also be able to offer the user the maximum freedom of movement of the hand and flexibility when riding a motorcycle.

20 In motorcycle glove structures of the known type for protecting the hands, and especially the upper part of the fingers and the hand, plastic moulded parts are usually applied, these being formed so as not to limit the freedom of movement of the hand and therefore the rider.

25 However, these protective devices, while obtaining the desired results with regard to sliding on the ground or on the road surface, are not effective for preventing and therefore providing complete protection against possible injury (fractures, sprains, or the like) which may affect the hand in the event of the rider suffering an accident or fall.

30 A further aspect not given due consideration hitherto is that the known glove structures, although being provided on the upper part with rigid protective devices, as regards the leather or fabric part are made in a conventional manner which envisages a plurality of stitches; these stitches, precisely as a result of friction against the road surface and/or grit, are prone to abrasive damage so that the glove opens in the region of the fingers and in particular the finger tips, thereby increasing the risk of injury due to abrasion and impact.

35 A first object of the present invention is to provide a glove structure, in particular for motorcyclists, in which the stitches, in particular at the finger tips, are limited in terms of number and extent and protected, while providing at the same time rigid protection for the upper portion of the fingers.

A second object of the present invention is to provide a glove structure provided with a

system for protecting the back of the hand, which not only ensures adequate protection against impacts and sliding abrasion, but is also able to interact with the rigid protection system for the fingers in the region of the major knuckles of the hand and with a further part for protecting the wrist joint.

5 A further object of the present invention is to provide a glove structure which has a section for protecting the wrist joint, which helps transmit the forces acting on the hand in the event of an accident or fall of the rider, preventing backwards twisting of the hand relative to the wrist beyond physiologically acceptable limits.

10 Yet another object of the present invention is to provide an improved method for manufacturing motorcycle glove structures with improved characteristics.

These and other objects according to the present invention are achieved with the glove structure and with the method as defined in the claims.

15 The features and advantages of the present invention will emerge more clearly from the description which follows of a preferred embodiment, provided by way of a non-limiting example with reference to the accompanying drawings in which:

Figs. 1 and 2 are plan views of the glove according to the invention from the back side and from the palm side, respectively;

Fig. 3 is an exploded view of the glove according to the invention;

Fig. 4 is a cross-section along the plane IV-IV of Fig. 1;

20 Fig. 4a is a variant of Fig. 4;

Fig. 5 is a cross-section along the plane V-V of Fig. 1;

Fig. 5a is a view, similar to that of Fig. 5, which shows the glove in a different operating configuration;

25 Figs. 6 and 6a are views similar to Figs. 5 and 5a, along the cross-sectional plane VI-VI of Fig. 1;

Figs. 6b and 6c are variants of Fig. 6 and Fig. 6a, respectively.

30 With reference firstly to Figures 1-3, the glove structure according to the present invention consists of an actual glove - indicated by the generic reference number 10 - which is made of leather or other similar material or fabric and comprises four fingers 12, a thumb 14, a back zone 16 and a palm zone 18.

Accordingly, for the purposes of the present invention, the term finger must be interpreted as not including the thumb.

35 Furthermore, from the purpose of the present invention, the term upper portion of the finger is intended to relate to the portion of the finger corresponding to the back hand whereas the term lower portion of the finger is intended to relate to the opposite portion.

As shown in figures 1-3, the glove terminates in a sleeve which, when the glove is worn, extends beyond the wrist joint.

In Figure 3 the reference number 20 indicates a system for protecting the upper portion of the fingers which in reality is preferably formed integrally with the leather forming the glove fingers, as shown more clearly in Fig. 4 and Fig. 4a which relates to a variant.

From these figures it can be seen that each glove finger 12 consists of two elements (indicated respectively by the reference numbers 22 and 24) which are made of leather or also a similar material or a tough fabric and are joined together by stitching lines 25.

Preferably, the first element 22 is pre-shaped by means of a press in the form of a U and corresponds to the lower part of the finger, i.e. the fleshy part of the finger. The second element 24 is substantially flat.

A layer 26 of plastic material, preferably non-rigid polyurethane, is applied on top of the second element by means of direct injection or, alternatively, by means of an adhesive film or glue (not shown). Then a second layer 28 of plastic material, preferably rigid polyurethane, could be injection-moulded over the layer 26 so as to form together with the latter the upper protection 20 of the fingers. It should be noted that the illustration shown in Fig. 3 is to be interpreted regarding the finger protection system 20 as being not separate or separable from the fingers 12, but forming an integral part thereof.

From Figures 1 to 3 it can be seen how the layer 28 could be formed with protuberances - generally indicated by the reference number 30 - which are situated opposite the minor knuckles, i.e. the articulations of the phalanges of the fingers.

Moreover, further projections 32 could be provided opposite the major knuckles, these being shaped at the front (i.e. towards the finger tips) in the manner of a fingernail 34 and at the rear with a tapered portion 36 which is smaller in height, for the purpose explained below.

According to an important characteristic feature of the invention, the stitching lines 25, along the perimetral edges 22a and 24a of the elements 22 and 24 are no longer exposed in the finished glove and consequently are protected in the event of an accident. In fact, the stitches 25 are entirely or partly covered by the layer 26 in the case of Fig. 4 and are internal in the variant according to Fig. 4a.

With reference again to Figs. 1 and 3, the generic reference number 38 indicates a shield for protecting the back of the hand, which extends from the major knuckles, namely from the finger joints to a short distance from the wrist.

As shown in Fig. 3, the shield 38 consists at the front in a plurality of fingernail-shaped portions 40, which correspond in number to the number of fingers, said portions 40 being such as to mate with the tapered portions 36 of the projections 32 formed at the ends of the fingers close to the joint with the back of the hand, although mutual fastening means are not envisaged.

In other words, the portions 40, when the shield 38 is positioned on the back of the glove in the manner explained below, rest on top of and cover the tapered portions 36 of the

projections 32, forming an extension of the nail-like portions 34 of the protuberances 32.

The shield 38 also comprises a U-shaped part 42 which is designed to mate with the part where the thumb is attached to the glove body.

5 In order to fix the shield 38 to the glove body, the upper part of the glove has a projection 44, which has a substantially oval shape and is made of material such as Velcro® and the corresponding inner surface of the shield has a portion which is also lined with Velcro® so that the shield is removably secured in position.

10 Fixing of the shield to the glove body is completed with a strap-type closure which extends between the two lateral edges of the shield in the region of the wrist of the glove body.

Finally, the glove structure according to the present invention is completed by a sleeve 48 comprising a portion 50 permanently fixed to the glove body in the portion beyond the wrist and a flap or panel 52 able to be removably fixed to the portion 50 by means of two mating Velcro® surfaces (indicated by 50a and 52a in Fig. 2).

15 With reference now to Figures 5, 5a and 6, 6a, 6b, 6c, it is possible to appreciate the advantageous additional characteristics obtained with the glove structure according to the present invention.

20 When the hand - which during normal use when riding a motorcycle is curved forwards together with the glove (see Fig 5a) - is straightened, an interference arises between the shaped portion 40 of the shield 38 and the nail-like portion 34 of the projection 32 protecting the major knuckle (see Fig. 5). Said interference is guided by engagement of the bottom surface of the shaped portion 40 with the tapered portion 36 of the projection 32 and prevents the fingers from passing beyond the condition where they are aligned with the back of the hand.

25 At the same time, in the event of an accident with sliding, the continuous protection of the back of the glove and therefore the hand is ensured, avoiding the situation where the major knuckle zone is protected solely by the glove leather.

If we now consider Figures 6 and 6a, it can be easily seen how a rib 54 is provided integrally on the sleeve 48, parallel to the wrist of the glove.

30 In normal riding conditions there is no interference between sleeve 48 and shield 38, so that the riding action is not hindered (see Fig. 6).

35 In the event of an accident, where forces are transmitted from the fingers, so that the hand tends to arch with respect to the wrist and the arm, the rear edge 39 of the shield 38 comes into contact against the rib 54. In this way, the aforementioned forces are transmitted to the sleeve 48, avoiding disastrous consequences for the integrity of the wrist bones.

Figs. 6b and 6c show a variant of Fig. 6 and 6a, respectively, in which the rib 154 against which the rear edge 39 of the shield 38 comes into contact is a part which is fixed onto the

sleeve 48 slidably in the direction of the R in Fig. 6c. In this way it is possible to adjust, depending on the anatomical characteristics of each user, the amplitude of the maximum permissible arching of the hand relative to the wrist and to the arm. Fig. 6c therefore shows, by way of example, two possible arrangements L_1 and L_2 of the rib 154 on the sleeve 48 and the corresponding arching angles φ_1 and φ_2 .

The invention has been described in connection with a preferred embodiment, but it is understood that conceptually and mechanically equivalent modifications and variations are possible and may be applied without departing from the scope of the invention.

For example and firstly, the use of a shield 38 may be envisaged with a traditional glove structure having the usual protection system for the upper portion of the fingers, provided that this protection system comprises projections for protecting the major knuckles, such as those indicated by the reference number 32.

Secondly, it is possible to envisage providing a shield such as the shield 38 fixed permanently to the back of the glove, in which case it is not possible to use the glove in the so-called lightened version, namely with the shield 38 removed.

In the case of the shield 38 being permanently secured to the back of the glove, the possibility of defective positioning or detachment thereof is avoided, for example following an impact which causes its detachment from the Velcro® and/or the breakage of the closing and securing strap.

Finally, as regards the sleeve portion, it is clear that the rib 54, 154 performs a vital function for ensuring the transmission of forces acting on the fingers and/or on the hand, preventing them from being transmitted to more fragile zones of the human skeleton, such as the wrist zone or the region of the thumb articulation.

Finally it must be commented that the method of forming the glove fingers, with screening of the stitching and a substantial reduction of the latter, may also be easily applied to the manufacture of gloves of the traditional type provided solely with a rigid protection for the upper portion of the fingers.

CLAIMS

1. Glove structure for the motorcycling sector, wherein each finger (12) consists of two elements (22, 24) which are made of leather or similar material or fabric and are joined permanently together along joining lines (25), the glove structure comprising:

- 5
- a protecting device (20) for protecting the upper portion of the fingers;
 - a shield (38) for protecting the back hand portion;
 - a sleeve portion (48) fixed to the glove in the region beyond the wrist,

characterized in that the shield (38) is provided at the front and at the rear with projections (40, 39) able to be engaged by corresponding projections (32, 54, 154) provided on the protecting device (20) and on the sleeve portion (48).

10

2. Glove structure according to claim 1, characterized in that the first element (22) of each finger (12) is shaped in the form of a U and is designed to cover the lower portion of the finger; the second element (24) of each finger (12) being flat and covering the upper portion of the finger.

15 3. Glove structure according to claim 1 or 2, characterized in that the joining lines (25) between the first element (22) and the second element (24) of each finger (12) are entirely or partly covered by the protecting device (20).

4. Glove structure according to claim 1 or 2, characterized in that the joining lines (25) between the first element (22) and the second element (24) of each finger (12) are internal so as to be protected in the event of an accident.

20

5. Glove structure according to any preceding claim, characterized in that the projections (40) provided at the front of the shield (38) are shaped as fingernails.

6. Glove structure according to any preceding claim, characterized in that the projections (32) of the protecting device (20) provided opposite the major knuckles are shaped at the front in the manner of a fingernail (34) and at the rear with a tapered portion (36) which is smaller in height; the tapered portion (36) being able to be engaged by the bottom surface of the shaped projection (40) of the shield for preventing the fingers from passing beyond the condition where they are aligned with the rear of the hand.

25

7. Glove structure according to any preceding claim, characterized in that the sleeve portion (48) is provided with a rib (54, 154) which projects at right angles from its surface; said rib being engageable by the rear edge (39) of the shield when the hand tends to arch with respect to the wrist and the arm.

30

8. Glove structure according to claim 8, characterized in that the position of said rib (154) on the surface of the sleeve portion (48) is adjustable so as to allow the amplitude adjustment of the maximum permissible arching of the hand relative to the wrist and to the arm.

35

9. Glove structure according to any preceding claim, characterized in that the shield (38) comprises a U-shaped portion (42) which is designed to mate with the part where the thumb is attached to the glove body.

5 10. Glove structure according to any preceding claim, characterized in that the inner surface of the shield (38) has a portion lined with Velcro; said portion being suitable to be fixed to a projection (44) made of Velcro positioned of the back hand of the glove.

10 11. Glove structure according to claim 10, characterized in that the shield (38) is also fixed to the glove body by means of a strap-type closure which extends between the two lateral edges of the shield (38) in the region of the wrist of the glove body.

12. Glove structure according to any one of claim 1 to 9, characterized in that the shield (38) is permanently fixed to the back hand region of the glove.

15 13. Glove structure according to any preceding claim, characterized in that the protecting device (20) is formed by two layers of material (26, 28); the first layer (26) is applied on top of the element (24) of each finger (12) while the second layer (28) is applied over the first layer (26).

14. Glove structure according to claim 13, characterized in that the first layer (26) is made of non-rigid polyurethane; said first layer (26) being direct injected or glued on top of the element (24).

20 15. Glove structure according to claim 13, characterized in that the second layer (28) is made of rigid polyurethane; said second layer (26) being direct injected over the layer (26).

25 16. Glove structure according to any one of claim 13 to 15, characterized in that the second layer (28) is formed with protuberances (30) providing specific protection for the minor knuckles.

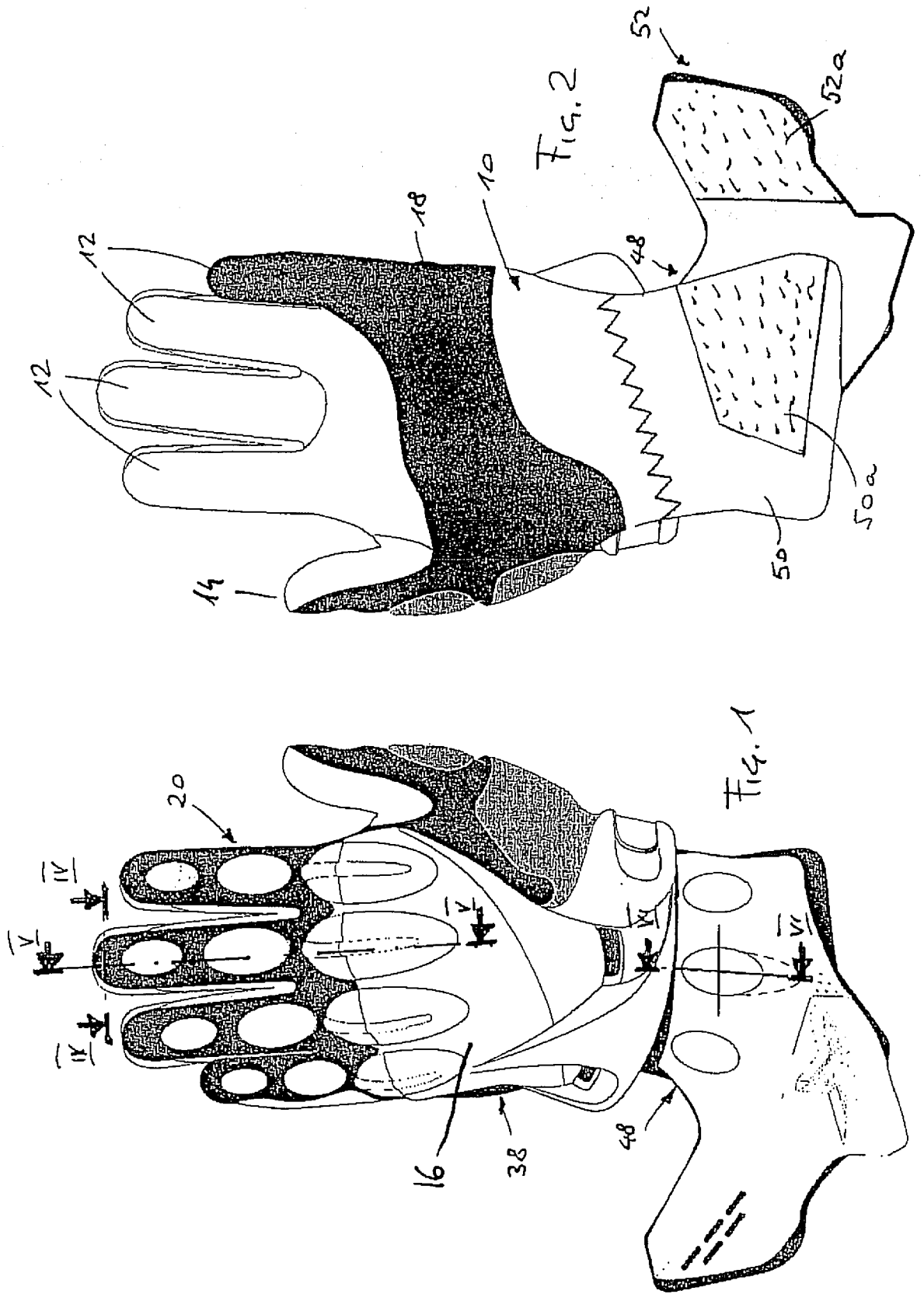
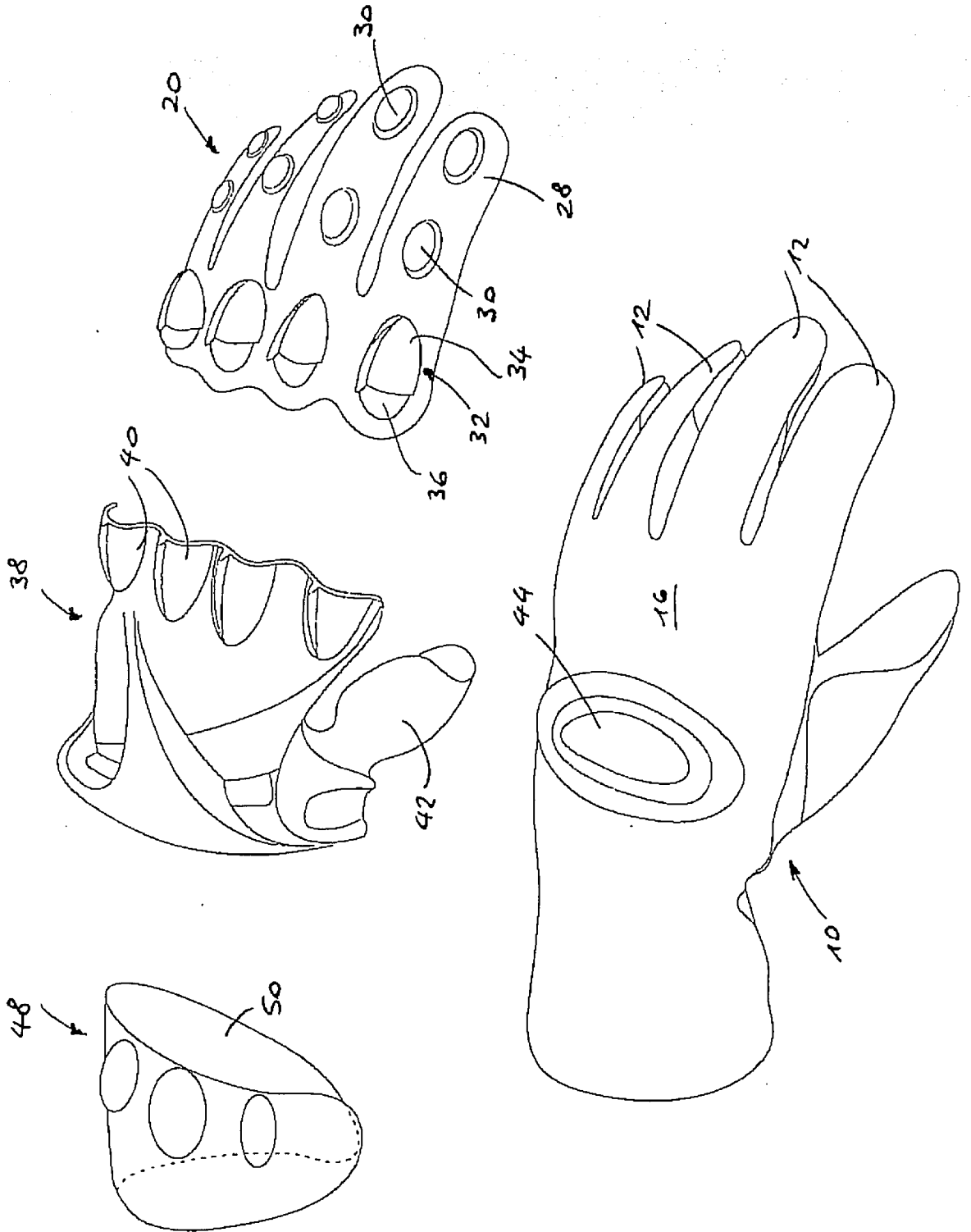

Fig. 3



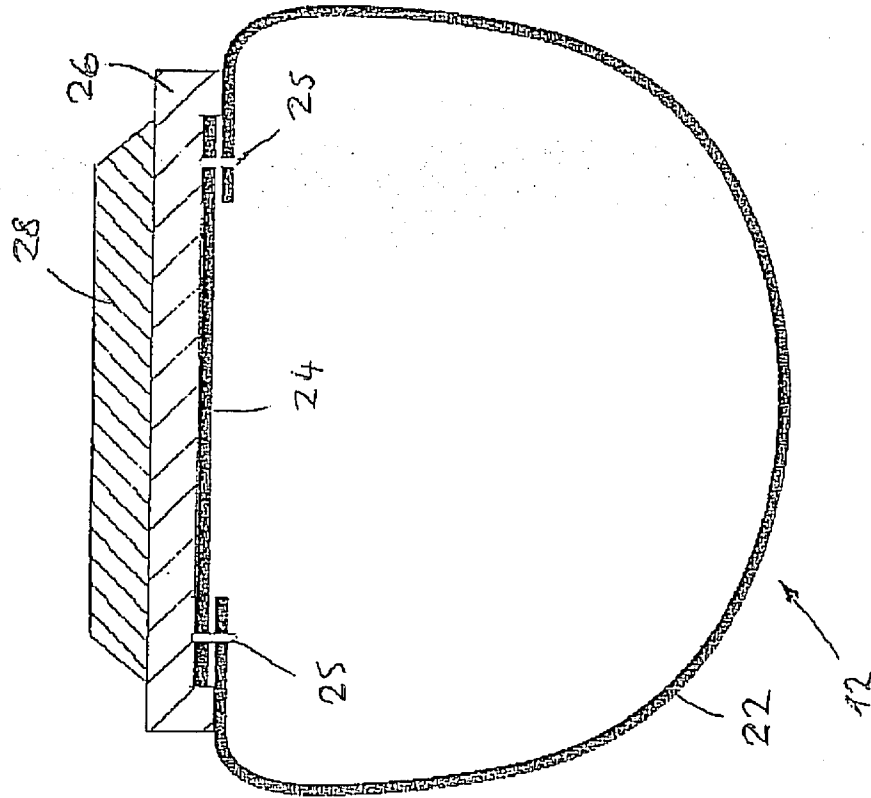

FIG. 4

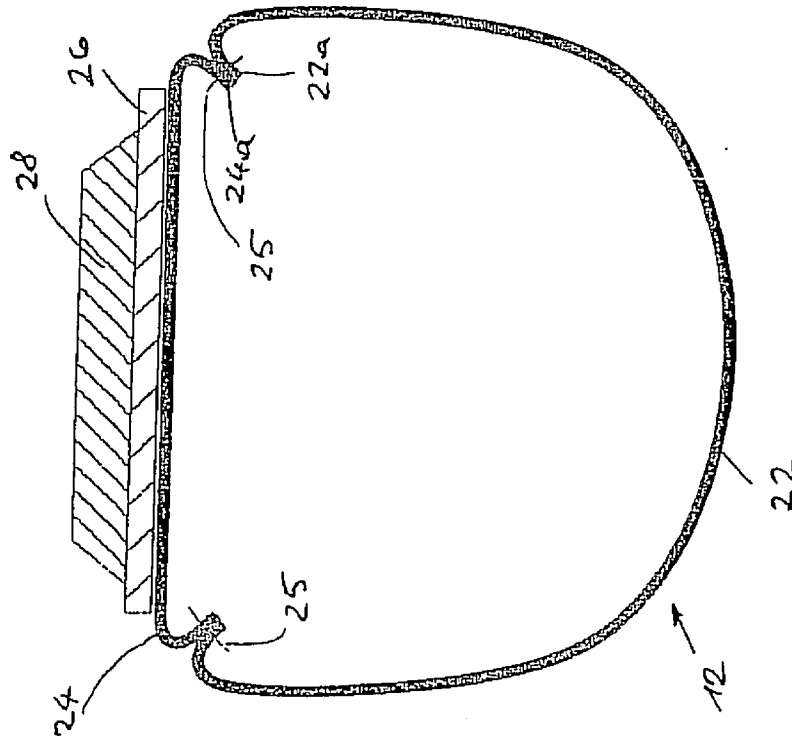

FIG. 4a

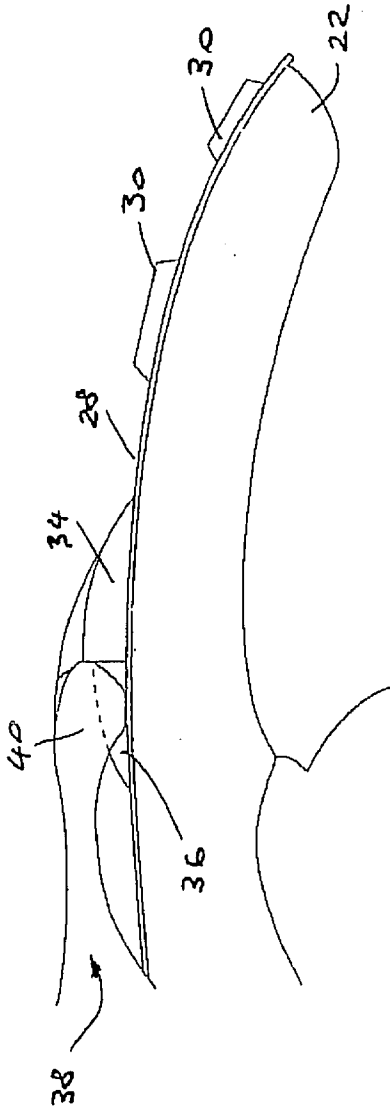

FIG. 5

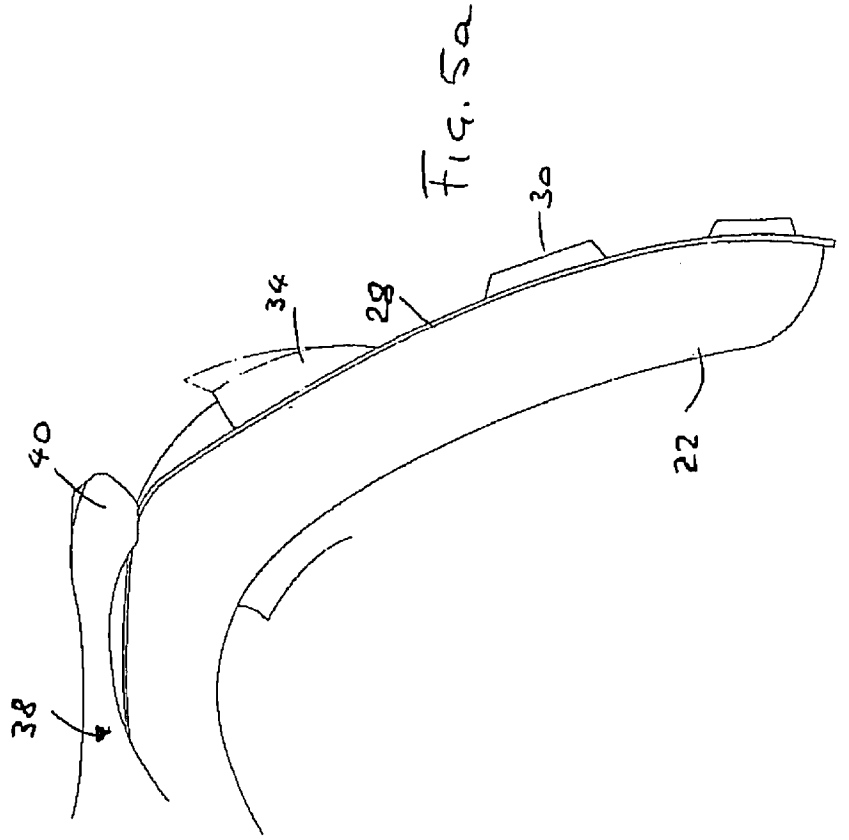

FIG. 5a

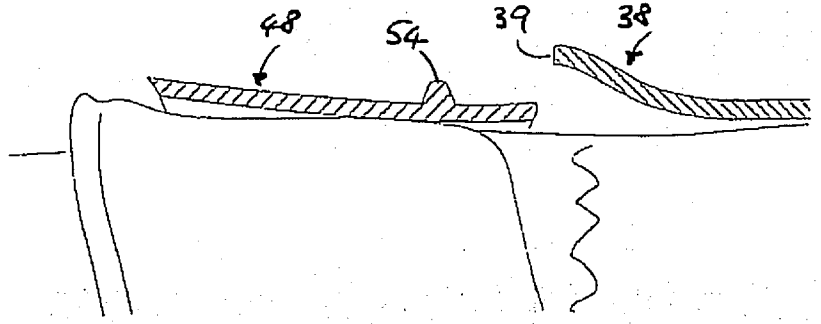

Fig. 6

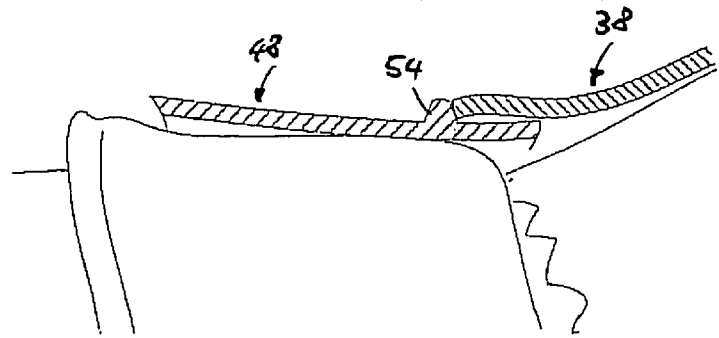

Fig. 6a

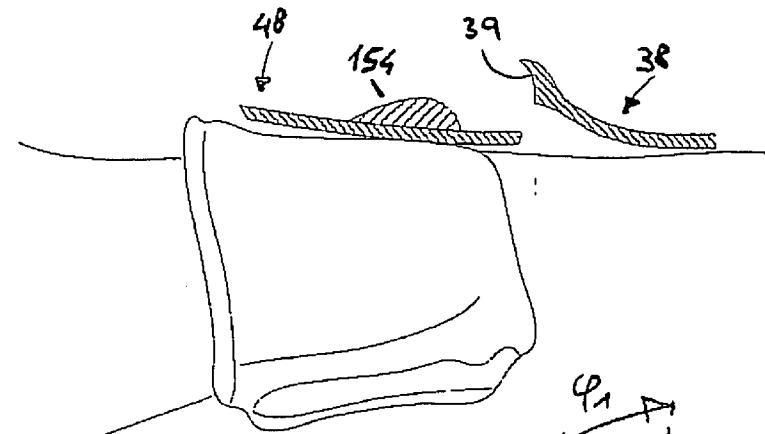

Fig. 6b

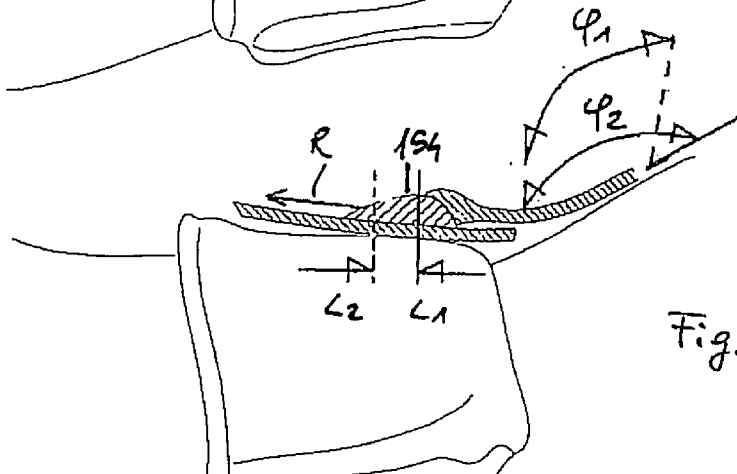

Fig. 6c

INTERNATIONAL SEARCH REPORT

International application No
PCT/IB2009/053574A. CLASSIFICATION OF SUBJECT MATTER
INV. A41D19/015 A63B71/14

According to International Patent Classification (IPC) or to both national classification and IPC

B. FIELDS SEARCHED

Minimum documentation searched (classification system followed by classification symbols)
A41D A63B

Documentation searched other than minimum documentation to the extent that such documents are included in the fields searched

Electronic data base consulted during the international search (name of data base and, where practical, search terms used)

EPO-Internal

C. DOCUMENTS CONSIDERED TO BE RELEVANT

Category*	Citation of document, with indication, where appropriate, of the relevant passages	Relevant to claim No.
Y	US 2006/010562 A1 (BEVIER JOSEPH J [US]) 19 January 2006 (2006-01-19) paragraphs [0040], [0041]; figures 8-10	1-5,9-16
Y	JP 09 262332 A (GIYAROTSUPU KK) 7 October 1997 (1997-10-07) abstract; figures	1-5,9-16
A	GB 2 368 775 A (TURNER SIMON GEORGE [GB]) 15 May 2002 (2002-05-15) page 6 - page 9; figures 3-9	1-16
A	WO 2005/053447 A (BM POLYCO LTD [GB]; STOKES LESLIE JAMES [GB]) 16 June 2005 (2005-06-16) page 21, paragraphs 3,4; figure 14	1
	-/--	

 Further documents are listed in the continuation of Box C. See patent family annex.

* Special categories of cited documents :

- *A* document defining the general state of the art which is not considered to be of particular relevance
- *E* earlier document but published on or after the international filing date
- *L* document which may throw doubts on priority claim(s) or which is cited to establish the publication date of another citation or other special reason (as specified)
- *O* document referring to an oral disclosure, use, exhibition or other means
- *P* document published prior to the international filing date but later than the priority date claimed

- *T* later document published after the international filing date or priority date and not in conflict with the application but cited to understand the principle or theory underlying the invention
- *X* document of particular relevance; the claimed invention cannot be considered novel or cannot be considered to involve an inventive step when the document is taken alone
- *Y* document of particular relevance; the claimed invention cannot be considered to involve an inventive step when the document is combined with one or more other such documents, such combination being obvious to a person skilled in the art.
- *&* document member of the same patent family

Date of the actual completion of the international search

27 November 2009

Date of mailing of the international search report

08/12/2009

Name and mailing address of the ISA/

European Patent Office, P.B. 5818 Patentlaan 2
NL - 2280 HV Rijswijk
Tel. (+31-70) 340-2040,
Fax: (+31-70) 340-3016

Authorized officer

Fonseca Fernandez, H

INTERNATIONAL SEARCH REPORT

International application No
PCT/IB2009/053574

C(Continuation). DOCUMENTS CONSIDERED TO BE RELEVANT		
Category*	Citation of document, with indication, where appropriate, of the relevant passages	Relevant to claim No.
A	US 2007/020435 A1 (WILLIAMS COLE [US]) 25 January 2007 (2007-01-25) figures 8,9 -----	1
A	US 2 448 697 A (ROBERT BAKKE) 7 September 1948 (1948-09-07) figures 1-3 -----	1
A	WO 02/076249 A (DAINESE SPA [IT]; DAINESI LINO [IT]) 3 October 2002 (2002-10-03) figures 1,10,11 -----	1

INTERNATIONAL SEARCH REPORT

Information on patent family members

International application No PCT/IB2009/053574

Patent document cited in search report	Publication date	Publication date	Patent family member(s)	Publication date
US 2006010562 A1	19-01-2006		NONE	
JP 9262332 A	07-10-1997		JP 2990343 B2	13-12-1999
GB 2368775 A	15-05-2002		NONE	
WO 2005053447 A	16-06-2005		EP 1691636 A1 JP 2007513264 T	23-08-2006 24-05-2007
US 2007020435 A1	25-01-2007		US 2008260962 A1	23-10-2008
US 2448697 A	07-09-1948		NONE	
WO 02076249 A	03-10-2002		AT 328502 T DE 60212133 T2 EP 1408782 A1 ES 2266486 T3 IT RM20010156 A1	15-06-2006 04-01-2007 21-04-2004 01-03-2007 23-09-2002