

L. BOGNER.

Improvement in Churns.

No. 130,104.

Patented Aug. 6, 1872.

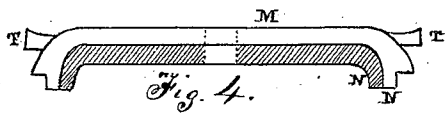
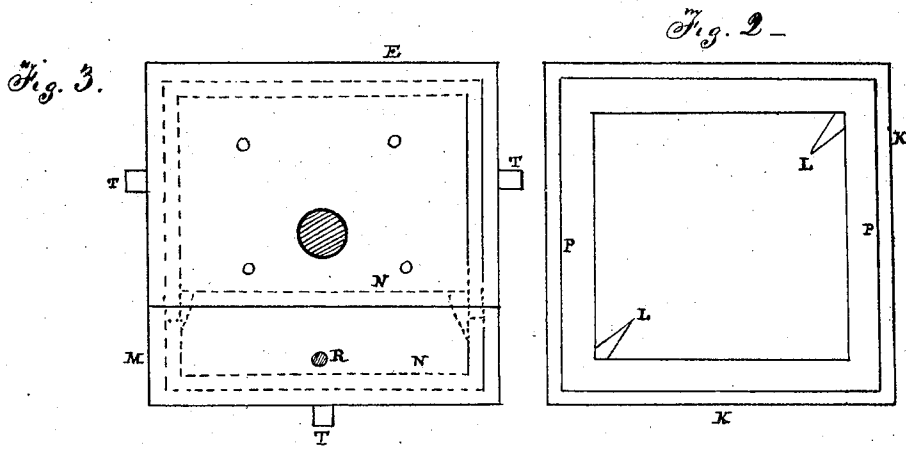
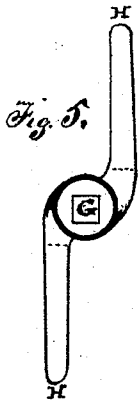
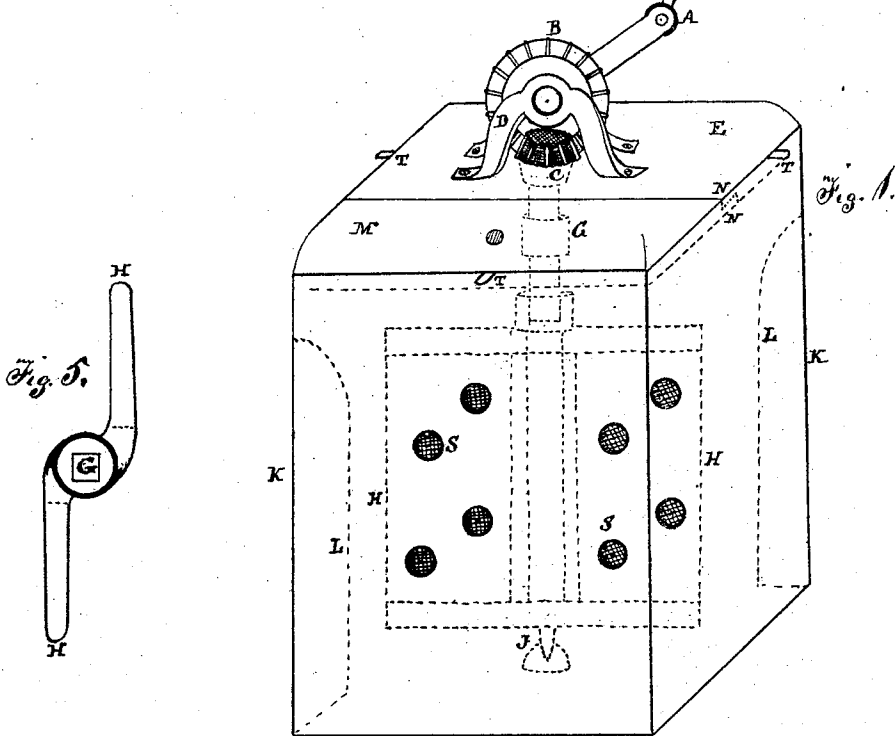

Witnesses—
Edw. F. Brown.
H. S. Miller.

Lewis Bogner—
By his Atty—
J. S. Peigan & P.

UNITED STATES PATENT OFFICE.

LEWIS BOGNER, OF ROCHESTER, INDIANA.

IMPROVEMENT IN CHURNS.

Specification forming part of Letters Patent No. **130,104**, dated August 6, 1872.

To all whom it may concern:

Be it known that I, LEWIS BOGNER, of Rochester, county of Fulton and State of Indiana, have invented an "Improved Cast-Iron Top for Churns;" and I do hereby declare the following to be an exact description thereof, reference being had to the accompanying drawing and to the letters of reference marked thereon making a part of this specification, in which—

Figure 1 represents a perspective view of the churn; Fig. 2, a top view of the churn-box, upon which the cast-iron top rests. Fig. 3 is a top view of the cast-iron top and its flanges on the under side, as shown by the dotted lines. Fig. 4 is a cross-section of the cast-iron top. Fig. 5 is a top view of the dasher, exhibiting the shape of the wings as they extend from the vertical spindle.

The nature of my invention consists in the shape and construction of the cast-iron top with its flanges underneath and bevel-gearing devices on the top, and the winged and curved dasher on the inside, when arranged, combined, and operating as herein described.

A is the crank that is attached to the upright bevel-wheel B, that gears into the horizontal bevel-wheel C; and D, the upright frame, that is firmly screwed or fastened to the cast-iron top E that supports the bevel-wheel B. The bevel-wheel C is the head of the spindle G, upon which the dasher H is fastened, and by which spindle or shaft the dasher is revolved by the operation of the crank A. J is the step in which the spindle G revolves. K is the square box of the churn, and L L are two projecting breakers that extend outward from the two

opposite corners of the inside of the box. E M is the cast-iron top or lid of the churn, constructed of cast-iron, in two pieces, having flanges N N underneath, so as to fit against the inside flange P of the upper side of the box K firmly and closely, to prevent the cream from escaping during the operation of churning. The flange N of the smaller part of the lid M slides under the cross-flange N of the larger lid E and forms a tight joint, the spindle G passing through the larger part of the lid, while the smaller part of the lid M can be raised and drawn out whenever required. The aperture R in the smaller part of the lid is intended for the escape of the air. The dasher H is formed of two wings, with apertures S to assist in breaking the cream, and cause it to revolve easier. These wings are curved at the spindle, and then extend in a straight line to their outer ends, as shown at Fig. 5. The side projections T of the cast-iron lid are intended as handles, by which the lid can be raised or removed when required, and they are cast solid with the lid.

What I claim as my invention, and desire to secure by Letters Patent, is—

The construction of the cast-iron top E M, with its flanges N underneath and bevel-gearing devices B and C on top, and the winged and curved dasher H, on the inside, when arranged, combined, and operating as herein described, and for the purposes set forth.

LEWIS BOGNER.

Witnesses:

J. W. BROWN,
J. BROWN.