

(19)



SUOMI - FINLAND

(FI)

PATENTTI- JA REKISTERIHALLITUS
PATENT- OCH REGISTERSTYRELSEN
FINNISH PATENT AND REGISTRATION OFFICE

(10) **FI 128397 B**
(12) **PATENTTIJULKAISU**
PATENTSKRIFT
PATENT SPECIFICATION

- (45) Patentti myönnetty - Patent beviljats - Patent granted **30.04.2020**
- (51) Kansainvälinen patenttiluokitus - Internationell patentklassifikation -
International patent classification
B07B 1/00 (2006.01)
B02C 21/02 (2006.01)
B07B 1/42 (2006.01)
- (21) Patenttihakemus - Patentansökning - Patent application 20186127
- (22) Tekemispäivä - Ingivningsdag - Filing date **21.12.2018**
- (23) Saapumispäivä - Ankomstdag - Reception date **21.12.2018**
- (43) Tullut julkiseksi - Blivit offentlig - Available to the public **30.04.2020**

- (73) Haltija - Innehavare - Proprietor
1 •Metso Minerals, Inc., Lokomonkatu 3, 33900 TAMPERE, SUOMI - FINLAND, (FI)
- (72) Keksijä - Uppfinnare - Inventor
1 •Salminen, Vesa-Matti, TAMPERE, SUOMI - FINLAND, (FI)
- (74) Asiamies - Ombud - Agent
Espatent Oy, Kaivokatu 10 D, 00100 Helsinki
- (54) Keksinnön nimitys - Uppfinningens benämning - Title of the invention
Liikutettava mineraalimateriaalin käsittelylaitos ja menetelmä liikutettavassa mineraalimateriaalin käsittelylaitoksessa
Rörlig anläggning för processning av mineralmaterial och förfarande i en rörlig anläggning för processning av mineralmaterial
Mobile mineral material processing station and a method in a mobile mineral material processing station
- (56) Viitejulkaisut - Anförda publikationer - References cited
WO 9512462 A1, JP 2012200655 A, JP S6017279 U, GB 2309923 A, EP 2359944 A2, US 4981204 A
- (57) Tiivistelmä - Sammandrag - Abstract

Liikutettava mineraalimateriaalin käsittelylaitos (100), jolla on liikutettava alusta (110); runko, jota tukee, tai jonka muodostaa, liikutettava alusta (110); runkoon (120) tuettuna linjassa: seulan (140); ja poistokuljettimen (150); ainakin yksi toimilaite (160) järjestettynä kallistamaan seulaa (140) ensimmäiseen kiertosuuntaan; ja kallistusmekanismi (132, 134, 136, 152, 154) järjestettynä kallistamaan poistokuljetinta (150), synkronoituna seulan (140) kanssa, toiseen kiertosuuntaan vastakkain ensimmäiseen kiertosuuntaan nähden, kun toimilaite (160) kallistaa seulaa (140) ensimmäiseen kiertosuuntaan.

A mobile mineral material processing station (100) that has a mobile platform (110); a frame (120) supported by or formed by the mobile platform (110); supported by the frame (120) in line: a screen (140); and an exit conveyor (150); at least one actuator (160) configured to tilt the screen (140) in a first rotational direction; and a tilting mechanism (132, 134, 136, 152, 154) configured to tilt the exit conveyor (150), synchronized with the screen (140), in a second rotational direction opposite to the first rotational direction when the actuator (160) tilts the screen (140) in the first rotational direction.

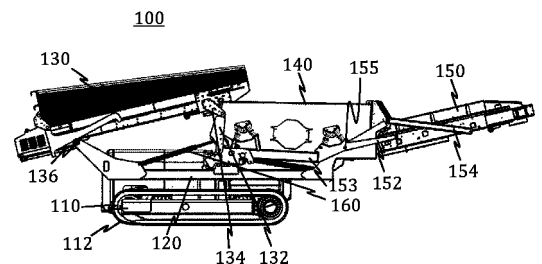

MOBILE MINERAL MATERIAL PROCESSING STATION AND A METHOD IN A MOBILE MINERAL MATERIAL PROCESSING STATION

TECHNICAL FIELD

5 The present invention generally relates to a mobile mineral material processing station. The invention relates particularly, though not exclusively, transformation of the mobile mineral material processing station between compacted transportation configuration and extended operating configuration.

10 BACKGROUND ART

This section illustrates useful background information without admission of any technique described herein representative of the state of the art.

15 Mineral material is processed by screening or crushing with mobile stations that are self-propelled or towable. Mobility of such stations is improved by compacting to a transport configuration. GB 2526769 A presents an example of a mobile screening apparatus for handling bulk material and especially in a portable or mobile format. The apparatus of GB 2526769 A has a feed conveyor and screen that can be brought to overlap and tilt upwards by their adjacent ends and also three exit conveyors, two of
20 which can be folded onto the screen so that the entire apparatus is largely compacted for ease of transportation. The foldable side conveyors appear to be manually foldable and there are rectangular profiled telescopic supports for holding the foldable side conveyors in an extended configuration. A central exit conveyor is fixedly mounted.

25 It is an object of the invention to enhance portability of a mobile mineral material processing station or to improve an operating configuration of the mobile mineral material processing station or to at least provide a new technical alternative.

SUMMARY

30 According to a first example aspect of the invention there is provided a mobile mineral material processing station comprising:

a mobile platform comprising tracks or wheels or a skids;

a frame supported by or formed by the mobile platform;
supported by the frame in line: a screen; and an exit conveyor; and
at least one actuator configured to tilt the screen in a first rotational direction.

5 The mobile mineral material processing station is characterized by a tilting mechanism configured to tilt the exit conveyor, synchronized with the screen, in a second rotational direction opposite to the first rotational direction when the actuator tilts the screen in the first rotational direction.

10 The mobile mineral material processing station may further comprise a feed conveyor. The feed conveyor may be supported by the frame in line with the screen and exit conveyor. The tilting mechanism may be configured to tilt the feed conveyor and the exit conveyor synchronized with the screen in the second rotational direction opposite to the first rotational direction when the actuator tilts the screen in the first
15 rotational direction.

The tilting mechanism may be further configured maintain the exit conveyor at a distance from the screen that remains constant during the tilting of the exit conveyor.

20 The mobile platform may comprise tracks. The mobile platform may comprise wheels. The mobile platform may comprise skids.

The at least one actuator may comprise or be a linear actuator. The at least one actuator may comprise or be a hydraulic actuator. The at least one actuator may comprise or be
25 a pneumatic actuator. The at least one actuator may comprise or be an electric hydraulic actuator.

The tilting mechanism may comprise feed conveyor tilting arms. The tilting mechanism may comprise exit conveyor tilting arms. The feed conveyor tilting arms may comprise
30 a first sub-arm and a second sub-arm that are pivotably connected to each other. The first sub-arm may be functionally connected to the screen to move with the screen. The

second sub-arm may be functionally connected to the feed conveyor to move with feed conveyor. The actuator may be connected to the first sub-arm.

5 The tilting mechanism may be configured to tilt the feed conveyor and the exit conveyor by angles deviating at most 1 degree, 5 degrees, 10 degrees, 15 degrees or 20 degrees.

The tilting of the screen in the first rotational direction may increase sloping down of the screen away from the feed conveyor.

10

The screen may be rotated from a compacted orientation to an operating orientation by the tilting in the first rotational direction. The compacted orientation may be parallel with a ground line of the mobile platform. The ground line may be ground-facing parts of the mobile platform when seen from a side perpendicularly to longitudinal direction of the mobile mineral material processing station.

15

The feed conveyor may be rotated from a compacted orientation to an operating orientation by the tilting in the second rotational direction. The compacted orientation may be parallel with a ground line of the mobile platform or deviate from the parallel with the ground line by at most 1 degree, 5 degrees, 10 degrees or 15 degrees.

20

The exit conveyor may be rotated from a compacted orientation to an operating orientation by the tilting in the second rotational direction. The compacted orientation may be parallel with a ground line of the mobile platform.

25

Advantageously, the mechanism provides that the tail end of the conveyor follows the screen when screen angle is changed. This reduces problems related on varying distance between the screen and the conveyor. Also transport height may be lowered without costly separate mechanism.

30

According to a second example aspect of the invention there is provided a method in a mobile mineral material processing station comprising a mobile platform having tracks or wheels or a skids, the method comprising:

- 5 supporting or forming a frame by the mobile platform;
- supporting by the frame in line: a screen; and an exit conveyor; and
- tilting by at least one actuator the screen in a first rotational direction.

The method is characterized by tilting by a tilting mechanism the exit conveyor, synchronized with the screen, in a second rotational direction opposite to the first rotational direction when the actuator tilts the screen in the first rotational direction.

Different non-binding example aspects and embodiments of the present invention have been illustrated in the foregoing. The embodiments in the foregoing are used merely to explain selected aspects or steps that may be utilized in implementations of the present invention. Some embodiments may be presented only with reference to certain example aspects of the invention. It should be appreciated that corresponding embodiments may apply to other example aspects as well.

BRIEF DESCRIPTION OF THE DRAWINGS

Some example embodiments of the invention will be described with reference to the accompanying drawings, in which:

Fig. 1 shows in a partly extended configuration a mobile mineral material processing station; and

Fig. 2 shows the mobile mineral material processing station in an operating configuration.

DETAILED DESCRIPTION

In the following description, like reference signs denote like elements or steps.

Fig. 1 shows in a partly extended configuration a mobile mineral material processing station 100, or station 100 in short. The station comprises:

- a mobile platform 110 comprising tracks 112 or wheels or a skids;

a frame 120 supported by or formed by the mobile platform;
supported by the frame 120 in line: an optional feed conveyor 130; a screen 140; and an exit conveyor 150;

at least one actuator 160 configured to tilt the screen 140 in a first rotational direction; and

a tilting mechanism 132, 134, 136, 152, 154 configured to tilt the feed conveyor 130 (optional) and the exit conveyor 150 synchronized with the screen 140 in a second rotational direction opposite to the first rotational direction when the actuator 160 tilts the screen 140 in the first rotational direction.

10

The tilting mechanism 132, 134, 136, 152, 154 of Fig. 1 comprises:

- a first sub-arm 132 and a second sub-arm 134 that are pivotably connected to each other and together link the feed conveyor 130 to the screen 140;
- a sliding support 136 for another end of the feed conveyor 130;
- 15 - a lower arm 152 fixedly connected to a sub frame 153 of the screen 140 and extending to pivotably connect with a receiving end of the exit conveyor 150;
- the sub frame 153 is pivotably 155 connected to the frame 120
- a body arm 154 for suspending the exit conveyor 150 from a pivot point fixed in relation to the frame 120.

20

In an embodiment, the exit conveyor 150 is maintained by the tilting mechanism at a constant distance from the screen 140.

25

In Fig. 1, there are two actuators 160 at both sides of the station 100. The actuators 160 of Fig. 1 are linear actuators such as hydraulic or pneumatic cylinders. Furthermore, in the station 100 of Fig. 1, there the drawn parts of the tilting mechanism are provided on both sides of the station 100.

30

The actuators 160 of Fig. 1 are connected to the first sub-arms 132 of the same side of the station 100 so that all of the feed conveyor 130, screen 140 and the exit conveyor 150 can be retracted in line and in a succession one after another and then extended again so that the tilting mechanism tilts also all of the feed conveyor 130, screen 140

and the exit conveyor 150 simultaneously and synchronously. A discharging end of the exit conveyor 150 is lifted by the tilting mechanism higher up so that bigger piles can be formed or direct loading to trucks is facilitated, whereas the retracted configuration can still be maintained relatively low for facilitating transport.

5

The tilting mechanism may be configured to tilt the feed conveyor and the exit conveyor by angles deviating at most 1 degree, 5 degrees, 10 degrees, 15 degrees or 20 degrees.

10 The tilting of the screen 140 in the first rotational direction may increase sloping down of the screen 140 away from the feed conveyor.

Fig. 2 shows the station 100 in an operating configuration in which the screen 140 has been rotated from a compacted orientation to an operating orientation by tilting in the first rotational direction. As shown in Fig. 1, the compacted orientation can be parallel
15 with a ground line of the mobile platform or deviate from the parallel by at most by 1 degree, 5 degrees, 10 degrees or 15 degrees.

Fig. 2 also shows that the feed conveyor 130 has been rotated from a compacted
20 orientation to an operating orientation by the tilting in the second rotational direction and that the exit conveyor 150 has been rotated from a compacted orientation to an operating orientation by the tilting in the second rotational direction.

Various embodiments have been presented. It should be appreciated that in this
25 document, words comprise, include and contain are each used as open-ended expressions with no intended exclusivity.

The foregoing description has provided by way of non-limiting examples of particular
30 implementations and embodiments of the invention a full and informative description of the best mode presently contemplated by the inventors for carrying out the invention. It is however clear to a person skilled in the art that the invention is not restricted to details of the embodiments presented in the foregoing, but that it can be

implemented in other embodiments using equivalent means or in different combinations of embodiments without deviating from the characteristics of the invention.

- 5 Furthermore, some of the features of the afore-disclosed embodiments of this invention may be used to advantage without the corresponding use of other features. As such, the foregoing description shall be considered as merely illustrative of the principles of the present invention, and not in limitation thereof. Hence, the scope of the invention is only restricted by the appended patent claims.

10

Claims:

1. A mobile mineral material processing station (100) comprising:
a mobile platform (110);
5 a frame (120) supported by or formed by the mobile platform (110);
supported by the frame (120) in line: a screen (140); and an exit conveyor
(150); and

at least one actuator (160) configured to tilt the screen (140) in a first rotational
direction; **characterized** in that the mobile mineral material processing station
10 (100) further comprises:

a tilting mechanism (132, 134, 136, 152, 154) configured to tilt the exit
conveyor (150), synchronized with the screen (140), in a second rotational direction
opposite to the first rotational direction when the actuator (160) tilts the screen (140)
in the first rotational direction.

15

2. The mobile mineral material processing station (100) of claim 1, wherein the
tilting mechanism (132, 134, 136, 152, 154) is further configured maintain the exit
conveyor (150) at a distance from the screen (140) that remains constant during the
tilting of the exit conveyor.

20

3. The mobile mineral material processing station (100) of claim 1 or 2, wherein:
the mobile mineral material processing station (100) further comprises a feed
conveyor (130); and

the feed conveyor (130) is supported by the frame (120) in line with the screen
25 (140) and the exit conveyor (150).

4. The mobile mineral material processing station (100) of claim 3, wherein the
tilting mechanism (132, 134, 136, 152, 154) is configured to tilt the feed conveyor
(130) and the exit conveyor (150) synchronized with the screen (140) in the second
30 rotational direction opposite to the first rotational direction when the actuator (160)
tilts the screen (140) in the first rotational direction.

5. The mobile mineral material processing station (100) of any one of preceding claims, wherein:

the tilting mechanism (132, 134, 136, 152, 154) comprises feed conveyor tilting arms which comprise a first sub-arm (132) and a second sub-arm (134) that are pivotably connected to each other;

the first sub-arm (132) is functionally connected to the screen (140) to move with the screen (140); and

the second sub-arm (134) is functionally connected to the feed conveyor (130) to move with feed conveyor (130).

10

6. The mobile mineral material processing station (100) of any one of preceding claims, wherein the actuator (160) is connected to the first sub-arm (132).

7. The mobile mineral material processing station (100) of any one of preceding claims, wherein the tilting mechanism (132, 134, 136, 152, 154) is configured to tilt the feed conveyor (130) and the exit conveyor (150) by angles deviating at most 20 degrees.

8. The mobile mineral material processing station (100) of any one of preceding claims, wherein the tilting of the screen (140) in the first rotational direction increases sloping down of the screen (140) away from the feed conveyor (130).

9. The mobile mineral material processing station (100) of any one of preceding claims, wherein the screen (140) is rotated from a compacted orientation to an operating orientation by the tilting in the first rotational direction.

10. The mobile mineral material processing station (100) of any one of preceding claims, wherein the feed conveyor (130) is rotated from a compacted orientation to an operating orientation by the tilting in the second rotational direction.

30

11. The mobile mineral material processing station (100) of any one of preceding claims, wherein the exit conveyor (150) is rotated from a compacted orientation to an operating orientation by the tilting in the second rotational direction.

12. The mobile mineral material processing station (100) of any one of claims 7 to 9, wherein the compacted orientation is parallel with a ground line of the mobile platform (110).

5

13. A method in a mobile mineral material processing station (100) comprising a mobile platform (110) having tracks or wheels or a skids, the method comprising:

supporting or forming a frame (120) by the mobile platform (110);

supporting by the frame (120) in line: a screen (140); and an exit conveyor

10 (150); and

tilting by at least one actuator (160) the screen (140) in a first rotational direction; **characterized** by further:

tilting by a tilting mechanism (132, 134, 136, 152, 154) the exit conveyor (150), synchronized with the screen (140), in a second rotational direction opposite to the

15 first rotational direction when the actuator (160) tilts the screen (140) in the first rotational direction.

1. Liikutettava mineraalimateriaalin käsittelylaitos (100), joka käsittää:
liikutettavan alustan (110);
rungon (120), jota tukee, tai jonka muodostaa, liikutettava alusta (110);
runkoon (120) tuettuna linjassa: seulan (140); ja poistokuljettimen (150); ja
5 ainakin yhden toimilaitteen (160) järjestettynä kallistamaan seulaa (140)
ensimmäiseen kiertosuuntaan; **tunnettu** siitä, että liikutettava mineraalimateriaalin
käsittelylaitos (100) lisäksi käsittää:

kallistusmekanismin (132, 134, 136, 152, 154) järjestettynä kallistamaan
poistokuljetinta (150), synkronoituna seulan (140) kanssa, toiseen kiertosuuntaan
10 vastakkain ensimmäiseen kiertosuuntaan nähden, kun toimilaite (160) kallistaa seulaa
(140) ensimmäiseen kiertosuuntaan.

2. Vaatimuksen 1 mukainen liikutettava mineraalimateriaalin käsittelylaitos
(100), jossa kallistusmekanismi (132, 134, 136, 152, 154) on lisäksi järjestetty
15 pitämään poistokuljettimen (150) seulasta (140) etäisyydellä, joka säilyy vakiona
poistokuljettimen kallistamisen aikana.

3. Vaatimuksen 1 tai 2 mukainen liikutettava mineraalimateriaalin käsittelylaitos
(100), jossa:
20 liikutettava mineraalimateriaalin käsittelylaitos (100) lisäksi käsittää
syöttökuljettimen (130); ja
syöttökuljetin (130) on rungon (120) tukema linjassa seulan (140) ja
poistokuljettimen (150) kanssa.

25 4. Vaatimuksen 3 mukainen liikutettava mineraalimateriaalin käsittelylaitos
(100), jossa kallistusmekanismi (132, 134, 136, 152, 154) on järjestetty kallistamaan
syöttökuljetinta (130) ja poistokuljetinta (150) synkronoituna seulan (140) kanssa
toiseen kiertosuuntaan vastakkain ensimmäiseen kiertosuuntaan nähden, kun
toimilaite (160) kallistaa seulaa (140) ensimmäiseen kiertosuuntaan.

30 5. Minkä tahansa edellisen vaatimuksen mukainen liikutettava
mineraalimateriaalin käsittelylaitos (100), jossa:

kallistusmekanismi (132, 134, 136, 152, 154) käsittää syöttökuljettimen kallistusvarret, jotka käsittävät ensimmäisen alivarren (132) ja toisen alivarren (134), jotka ovat toisiinsa nähden käännettävästi liitetty toisiinsa;

5 ensimmäinen alivarsi (132) on toiminnallisesti yhdistetty seulaan (140) liikkumaan seulan (140) mukana; ja

toinen alivarsi (134) on toiminnallisesti yhdistetty syöttökuljettimeen (130) liikkumaan syöttökuljettimen (130) mukana.

6. Minkä tahansa edellisen vaatimuksen mukainen liikutettava
10 mineraalimateriaalin käsittelylaitos (100), jossa toimilaite (160) on yhdistetty ensimmäiseen alivarteeseen (132).

7. Minkä tahansa edellisen vaatimuksen mukainen liikutettava
15 mineraalimateriaalin käsittelylaitos (100), jossa kallistusmekanismi (132, 134, 136, 152, 154) on järjestetty kallistamaan syöttökuljetinta (130) ja poistokuljetinta (150) kulmilla, jotka poikkeavat enintään 20 astetta.

8. Minkä tahansa edellisen vaatimuksen mukainen liikutettava
20 mineraalimateriaalin käsittelylaitos (100), jossa kallistamisen seula (140) ensimmäiseen kiertosuuntaan kasvattaa seulan (140) kallistusta alas pois päin syöttökuljettimesta (130).

9. Minkä tahansa edellisen vaatimuksen mukainen liikutettava
25 mineraalimateriaalin käsittelylaitos (100), jossa seula (140) kierretään kokoonpannusta asennosta toiminta-asentoon kallistamalla ensimmäiseen kiertosuuntaan.

10. Minkä tahansa edellisen vaatimuksen mukainen liikutettava
30 mineraalimateriaalin käsittelylaitos (100), jossa syöttökuljetinta (130) kierretään kokoonpannusta asennosta toiminta-asentoon kallistamalla toiseen kiertosuuntaan.

11. Minkä tahansa edellisen vaatimuksen mukainen liikutettava mineraalimateriaalin käsittelylaitos (100), jossa poistokuljetinta (150) kierretään kokoonpannusta asennosta toiminta-asentoon kallistamalla toiseen kiertosuuntaan.

5 12. Minkä tahansa vaatimuksen 7-9 mukainen liikutettava mineraalimateriaalin käsittelylaitos (100), jossa kokoonpantu asento on samansuuntainen liikutettavan alustan (110) maalinjan kanssa.

10 13. Menetelmä liikutettavassa mineraalimateriaalin käsittelylaitoksessa (100), joka käsittää liikutettavan alustan (110), jolla on telat tai pyörät tai jalakset, jossa menetelmässä:

tuetaan runkoa (120) tai muodostetaan runko (120) liikutettavalla alustalla (110);

tuetaan rungolla (120) linjaan: seula (140); ja poistokuljetin (150); ja

15 kallistetaan ainakin yhdellä toimilaitteella (160) seulaa ensimmäiseen kiertosuuntaan; **tunnettu** siitä, että lisäksi: kallistetaan kallistusmekanismilla (132, 134, 136, 152, 154) poistokuljetinta (150), synkronoituna seulan (140) kanssa, toiseen kiertosuuntaan vastakkain ensimmäiseen kiertosuuntaan nähden, kun toimilaitte (160) kallistaa seulaa (140) ensimmäiseen kiertosuuntaan.

20

Fig. 1 100

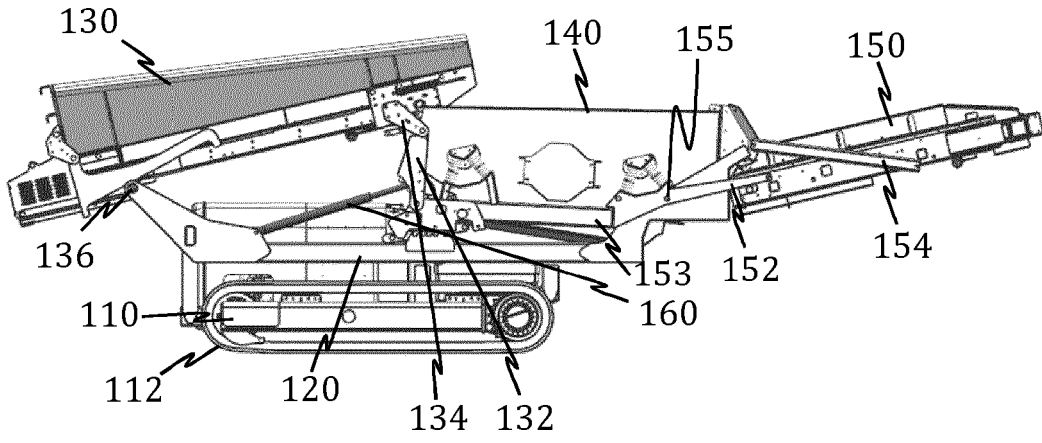

Fig. 2

