

(19) World Intellectual Property Organization  
International Bureau



(43) International Publication Date  
19 July 2007 (19.07.2007)

PCT

(10) International Publication Number  
**WO 2007/081719 A2**

(51) International Patent Classification:  
*H01L 33/00* (2006.01)

(21) International Application Number:  
PCT/US2007/000102

(22) International Filing Date: 3 January 2007 (03.01.2007)

(25) Filing Language: English

(26) Publication Language: English

(30) Priority Data:  
60/756,845 5 January 2006 (05.01.2006) US

(71) Applicant (for all designated States except US): **ILLUMITEX** [US/US]; 4717 Eagle Feather Drive, Austin, TX 78735 (US).

(72) Inventors; and

(75) Inventors/Applicants (for US only): **DUONG, Dung, T.** [US/US]; 2515 Durlston Court, Cedar Park, TX 78613 (US). **WINBERG, Paul, N.** [US/US]; 603 Riley Road, Rollingwood, TX 78746 (US). **THOMAS, Matthew, R.** [US/US]; 4717 Eagle Feather Drive, Austin, TX 78735 (US).

(74) Agent: **ADAIR, John, L.**; SPRINKLE IP LAW GROUP, 1301 W. 25TH STREET, Suite 408, Austin, TX 78705 (US).

(81) Designated States (unless otherwise indicated, for every kind of national protection available): AE, AG, AL, AM, AT, AU, AZ, BA, BB, BG, BR, BW, BY, BZ, CA, CH, CN, CO, CR, CU, CZ, DE, DK, DM, DZ, EC, EE, EG, ES, FI, GB, GD, GE, GH, GM, GT, HN, HR, HU, ID, IL, IN, IS, JP, KE, KG, KM, KN, KP, KR, KZ, LA, LC, LK, LR, LS, LT, LU, LV, LY, MA, MD, MG, MK, MN, MW, MX, MY, MZ, NA, NG, NI, NO, NZ, OM, PG, PH, PL, PT, RO, RS, RU, SC, SD, SE, SG, SK, SL, SM, SV, SY, TJ, TM, TN, TR, TT, TZ, UA, UG, US, UZ, VC, VN, ZA, ZM, ZW.

(84) Designated States (unless otherwise indicated, for every kind of regional protection available): ARIPO (BW, GH, GM, KE, LS, MW, MZ, NA, SD, SL, SZ, TZ, UG, ZM, ZW), Eurasian (AM, AZ, BY, KG, KZ, MD, RU, TJ, TM), European (AT, BE, BG, CH, CY, CZ, DE, DK, EE, ES, FI, FR, GB, GR, HU, IE, IS, IT, LT, LU, LV, MC, NL, PL, PT, RO, SE, SI, SK, TR), OAPI (BF, BJ, CF, CG, CI, CM, GA, GN, GQ, GW, ML, MR, NE, SN, TD, TG).

Published:

— without international search report and to be republished upon receipt of that report

For two-letter codes and other abbreviations, refer to the "Guidance Notes on Codes and Abbreviations" appearing at the beginning of each regular issue of the PCT Gazette.

(54) Title: SEPARATE OPTICAL DEVICE FOR DIRECTING LIGHT FROM AN LED

(57) Abstract: Embodiments of the present invention provide separate optical devices operable to couple to a separate LED, the separate optical device comprising an entrance surface to receive light from a separate LED when the separate optical device is coupled to the separate LED, an exit surface opposite from and a distance from the entrance surface and a set of sidewalls. The exit surface has at least a minimum area necessary to conserve brightness for a desired half-angle of light projected from the separate optical device. Furthermore, each sidewall is positioned and shaped so that at least a majority of rays having a straight transmission path from the entrance surface to that sidewall reflect to the exit surface with an angle of incidence at the exit surface at less than or equal to a critical angle at the exit surface.



WO 2007/081719 A2

**SEPARATE OPTICAL DEVICE FOR DIRECTING LIGHT FROM AN LED****RELATED APPLICATIONS**

[0001] This application claims the benefit of priority under 35 U.S.C. 119(e) to United States Provisional Application No. 60/756,845, entitled "Optical Device", to Duong et al., filed January 5, 2006, which is hereby fully incorporated by reference herein.

**TECHNICAL FIELD OF THE INVENTION**

[0002] The present invention relates to separate optical devices. Even more particularly, embodiments of the present invention relate to devices and methods that increase the ability to harness light from a separate light emitting diode ("LED").

**BACKGROUND**

[0003] Light emitting diodes ("LED") are ubiquitous in electronics. They are used in digital displays, lighting systems, computers and televisions, cellular telephones and a variety of other devices. In an LED, as in a traditional diode, extra electrons move from an N-type semiconductor to electron holes in a P-type semiconductor. In an LED, however, photons are released to produce light during this process. For many applications it is desirable to collect as much light as possible from the LED and distribute it into a desired cone angle.

[0004] Many conventional LED devices use a dome spherical or aspheric lens formed around the LED. Generally, the distance from the lens to the dome controls the emission cone. The T-1<sup>3</sup>/<sub>4</sub>, T-5mm or variations thereof are examples of dome lens LEDs. However, there are several drawbacks to this design. First, typical domes can only collect an f/1 acceptance angle of the LED die. Hence, photons emitted greater than this angle are either trapped within the dome due to total internal reflection ("TIR") or emitted out the edge of the dome at a non-usable angle. Next, the distribution of the light is highly dependent on the accuracy of the alignment between the chip and the dome. Therefore, far field and near field distributions are often sacrificed. Third, there can be significant non-uniformities between the near-field and far field distribution. Lastly, the distribution itself is not spatially uniform.

[0005] Another conventional scheme is to place a larger dome on top of the LED. Though this method does allow most if not all of the energy to get out, there are several significant drawbacks for practical applications. First, the emission cone angle is typically greater than 180 degrees. Though light is no longer trapped, energy is emitted to an angle greater than the original angle of the LED.

- 2 -

Mechanical housings and such can vignette, scatter and absorb the light at the larger angles. Moreover, since most secondary optical systems only collect an  $f/1$  cone (a cone having a half angle of approximately 30 degrees or less), much of the light is lost. Thirdly, since the dome is much larger than the LED die, the distribution is over a much larger area than necessary. This translates into a lower power density (or irradiance) when the light is focused.

[0006] Another solution is to place a TIR lens over the typical dome lens to collect all of the emitted energy and direct it into a smaller cone. This adds complexity to the system and only addresses the problem of getting more light into a narrower cone angle. These systems also do not address conservation of brightness of the source, creating a uniform pattern and maintaining the uniformity far field as well as near field. Also, adding such a TIR lens increases the size and cost of a lighting package as much as tenfold, rendering this solution impractical for nearly all LED applications in electronics and portable devices. Other systems utilize elaborate TIR lens, reflective collectors and condenser lens systems. While some reflective systems that re-image the LED from a dome can maintain the radiance (e.g., an ellipsoid where the LED is at one foci and the image is at the other foci), these systems are impractical for many applications.

#### SUMMARY OF THE INVENTION

[0007] Embodiments of the present invention provide separate optical devices and methods that substantially eliminate or reduce the shortcomings of previous separate optical device systems and methods. For purposes of this disclosure a "separate optical device" is an optical device that is formed independently from the LED, but may be molded in place on top of the LED.

[0008] One embodiment of the present invention includes a separate optical device operable to couple to an LED; the separate optical device comprises an entrance surface to receive light from a layer of a separate light emitting diode when the separate optical device is coupled to the LED, and an exit surface opposite from and a distance from the entrance surface. The exit surface has at least a minimum area necessary to conserve brightness for a desired half-angle of light emitted from the separate optical device. Furthermore, the separate optical device can include a set of sidewalls. Each sidewall may be positioned and shaped so that at least a majority of rays having a straight transmission path from the entrance surface to that sidewall reflect to the exit surface with an angle of

incidence at the exit surface at less than or equal to the critical angle at the exit surface.

[0009] Another embodiment of the present invention includes a separate optical device operable to couple to a separate LED, the separate optical device comprising an entrance surface to receive light from a layer of a separate non-circular LED when the separate optical device is coupled to the separate non-circular LED, an exit surface opposite from and a distance from the entrance surface, and a set of sidewalls. The exit surface, according to one embodiment, has at least a minimum area necessary to conserve brightness for a desired half-angle of light emitted from the separate optical device. Furthermore, each sidewall can be positioned and shaped so that at least a portion of rays having a straight transmission path from the entrance surface to that sidewall reflect to the exit surface with an angle of incidence at the exit surface at less than or equal to a critical angle at the exit surface. Each sidewall shape represents a superposition of multiple contoured surfaces. The area of the exit surface, distance and sidewall shapes can be selected to project light with a half angle of between 10 to 60 degrees with at least 60% efficiency and a desired intensity profile.

[0010] Another embodiment of the present invention includes a separate optical device configured to couple to a separate LED, the separate optical device comprising an entrance surface to receive light from a layer of a separate non-circular LED when the separate optical device is coupled to the separate non-circular LED, an exit surface opposite from and a distance from the entrance surface, and a set of sidewalls. The exit surface can have an area at least equal to a minimum area defined by  $\frac{n_1^2 A_1 \Omega_1}{n_2^2 \Omega_2}$ , wherein  $\Omega_1$  is the effective solid angle whereby light enters the entrance surface,  $\Omega_2$  is the effective solid angle whereby light leaves the exit surface,  $A_1$  is the area of the entrance surface,  $n_1$  is the refractive index of material of the separate optical device and  $n_2$  is the refractive index of the substance external to the separate optical device. The distance between the entrance surface and exit surface can be selected to be at least a minimum distance so that all rays with a straight transmission path from the entrance surface to the exit surface have an angle of incidence that is less than or equal to a critical angle at the exit surface. Furthermore, each sidewall can be positioned and shaped so that at least a portion of rays having a straight transmission path from the entrance surface to that sidewall reflect to the exit surface with an angle of incidence at the exit surface at less than or equal to the critical angle at the exit

surface. Each sidewall shape can represent a superposition of multiple contoured surfaces. The area of the exit surface, distance and sidewall shapes can be selected to project light with a half angle of between 10 to 60 degrees with at least 60% efficiency and a desired intensity profile.

- [0011] Embodiments of the present invention provide a separate optical device that provides technical advantages over the prior art by projecting light with a desired half-angle and intensity profile, while conserving brightness. Embodiments of the present invention can provide, for example, light in 10 to 60 degrees half angle (or other half angles) with 60-96% efficiency. Efficiencies can be higher than this (approaching 100%) with appropriate anti-reflection coatings on the exit surface or lower than this.
- [0012] Another advantage is that separate optical devices according to embodiments of the present invention can be much smaller (including greater than ten times smaller) than previous separate optical devices.
- [0013] Yet another advantage is that tight arrays of separate optical devices can be formed without or with very minimal losses.
- [0014] Embodiments of the present invention provide yet another advantage by providing for square or rectangular outputs with uniform or near uniform intensity distributions.
- [0015] Embodiments of the present invention provide another advantage by reducing or eliminating the need for secondary optics to create light with the desired half-angle.
- [0016] Embodiments of the present invention provide yet another advantage by providing separate optical devices that can project light with a desired aspect ratio without additional optics.
- [0017] Yet another advantage provided by embodiments of the present invention is that light can be projected with a desired shape and intensity profile in both near and/or far field.

#### BRIEF DESCRIPTION OF THE FIGURES

- [0018] A more complete understanding of the present invention and the advantages thereof may be acquired by referring to the following description, taken in conjunction with the accompanying drawings in which like reference numbers indicate like features and wherein:

- 5 -

- [0019] FIGURE 1 is a diagrammatic representation of one embodiment of an optical system including a separate optical device according to an embodiment of the present invention;
- [0020] FIGURE 2 is a diagrammatic representation of a set of rays traveling from a point to surfaces at different distances from the point;
- [0021] FIGURE 3 provides a diagrammatic representation of a top view of a separate optical device according to one embodiment of the present invention;
- [0022] FIGURE 4A is a diagrammatic representation of a cross-section of a model of a separate optical device for determining sidewall shapes;
- [0023] FIGURE 4B is a diagrammatic representation illustrating that the facets for a sidewall can be defined using a computer program;
- [0024] FIGURE 4C is a diagrammatic representation of one embodiment of a separate optical device with sidewalls shaped to cause TIR so that rays are reflected from the sidewalls to the exit surface;
- [0025] FIGURE 5 is a diagrammatic representation of one embodiment for estimating effective solid angle;
- [0026] FIGURES 6A-6E are diagrammatic representations describing another embodiment for estimating effective solid angle;
- [0027] FIGURE 7 is a diagrammatic representation of one embodiment of an array of separate optical devices;
- [0028] FIGURE 8 is a functional diagrammatic representation of a DLP system;
- [0029] FIGURE 9 is a diagrammatic representation of another embodiment of a separate optical device;
- [0030] FIGURE 10 is a diagrammatic representation of yet another embodiment of a separate optical device;
- [0031] FIGURE 11 is a diagrammatic representation of one embodiment of stacked separate optical devices; and
- [0032] FIGURE 12 is a diagrammatic representation of still another embodiment of a separate optical device.

#### DETAILED DESCRIPTION

- [0033] Preferred embodiments of the invention are illustrated in the FIGURES, like numerals being used to refer to like and corresponding parts of the various drawings.
- [0034] Embodiments of the present invention provide a separate optical device that is coupled to an LED to direct light from the LED to an exit interface of the separate

optical device. Ideally, the separate optical device is configured so that all the light entering the separate optical device from the LED is transmitted out the exit interface. To this end, the exit interface can be sized to take into account principles of conservation of radiance. The exit interface may be the minimum size that allows all light entering the separate optical device from the LED to exit the exit interface, thereby combining the desire to conserve radiance with the desire to reduce size. Additionally, the sidewalls of the device may be shaped so that reflection or total internal reflection ("TIR") causes light beams incident on the sidewalls to reflect towards the exit interface and be incident on the exit interface with an angle less than or equal to the critical angle. Consequently, light loss due to TIR at the exit interface is reduced or eliminated. For devices constructed of solid dielectric materials, use of TIR provides the advantage of lossless reflections. If the device is instead air-filled, then the sidewalls could be made of a reflective material which would introduce some minor losses.

[0035] While ideally 100% of the light entering the separate optical device exits the exit interface, various embodiments of the present invention may cause lesser amounts of light to exit the exit interface while still providing significant improvements over prior LED separate optical devices. More specifically, embodiments of the present invention allow light received from an LED to be emitted from the exit surface with a cone half angle of 10-60 degrees with approximately 50-96% efficiency (there is approximately a 4% efficiency loss due to fresnel losses for a dielectric material of 1.5 index of refraction) with a desired intensity profile.

[0036] FIGURE 1 is a diagrammatic representation of one embodiment of an optical system including a separate optical device 10, an LED 15 and a supporting structure 20. LED 15 includes a light emitting portion 25, typically a compound semiconductor such as InGaN or InGaP, and a substrate 30, such as sapphire substrate, silicon carbide (SiC) substrate or other substrate known or developed in the art. In FIGURE 1, the substrate 30 is positioned as typically embodied, above the light emitting portion 25; in another typical design, the substrate 30 may be positioned below the light emitting portion 25. Light from LED 15 is primarily transmitted through emitting surface 35 to separate optical device 10. LED 15 can be a wire bond, flip chip or other LED known or developed in the art. FIGURE 1 depicts the separate optical device affixed to the exit face of LED 15. Alternatively, it may be affixed to the substrate 20 and fully surround the LED 15.

- 7 -

- [0037] The thickness of LED 15 is shown much greater in comparison to separate optical device 10 than in an actual device, for clarity.
- [0038] Separate optical device 10 is formed separately from LED 15 and can be coupled to LED 15 or substrate 20 using a friction fit, optical cement or other coupling mechanism, whether mechanical, chemical, or otherwise. Preferably, separate optical device 10 is formed of a single, molded piece of dielectric, optically transmitting material with a single Index of Refraction ("IOR") "n", such as optically transparent silicone or acrylic, though other materials can be used. Furthermore, the IOR of separate optical device 10 is preferably within 20% of the IOR of substrate 30 (and ideally, IOR of separate optical device 10 is equal to or greater than IOR of substrate 30).
- [0039] Separate optical device 10 includes an entrance surface 50 to receive light transmitted from LED 15. Entrance surface 50, according to one embodiment, is the same shape as LED 15 and has an edge dimension approximately the same size as or slightly larger than the edge dimension of emitting surface 35 of LED 15. That is, the area of entrance surface 50 is approximately the same size as the area of LED 15 that transmits light to separate optical device 10, though entrance surface 50 may be slightly larger than LED 15 to account for tolerances in the manufacturing process, errors in alignment of separate optical device 10 and LED 15, or other factors. As an example, for a 1mm square LED, entrance surface 50 may be manufactured to be 1.075mm on each side.
- [0040] Separate optical device 10 further includes exit surface 55 that preferably is substantially the same shape as, substantially parallel to and substantially rotationally aligned with entrance surface 50 within the tolerance of the manufacturing process. The area of exit surface 55 can be chosen to conserve brightness for a desired half angle according to the conservation of radiance (sometimes called the conservation of brightness) equation:

$$\frac{\Phi_2 n_1^2 A_1 \Omega_1}{\Phi_1 n_2^2 \Omega_2} = A_2 \quad [\text{EQN. 1}]$$

$\Phi_1$  = light flux entering entrance surface 50;

$\Phi_2$  = light flux exiting exit surface 55,  $\Phi_1 = \Phi_2$  for conservation of brightness;

$\Omega_1$  = effective solid angle whereby light enters entrance surface 50;

$\Omega_2$  = effective solid angle whereby light leaves exit surface 55;

$A_1$  = area of entrance surface 50;

$A_2$  = area of exit surface 55;

$n_1$  = refractive index of material of separate optical device;



$n_2$  = refractive index of substance external to the exit of separate optical device 10 (e.g., typically air or other substance).

[0041]  $A_2$  represents the minimum surface area of exit surface 55 so that brightness is conserved per the above equation. Assume, for example: LED 15 is a 1mm square LED so that entrance surface 50 is approximately 1mm square,  $n_1 = 1.5$ ,  $n_2 = 1$ ,  $\Omega_1=3$ ,  $\Omega_2=1$ , then  $A_2$  must be at least  $6.75\text{mm}^2$  to conserve radiance. While in this example the effective solid angles are given, methods for determining  $\Omega_1$  and  $\Omega_2$  for a desired half angle are discussed below in conjunction with FIGURES 6A-6E.

[0042]  $A_2$  according to EQN. 1 is the minimum possible size for a given output cone angle or Emission Half Angle to conserve radiance. Consequently, to conserve radiance,  $A_2$  should be at least the size determined from EQN 1, but may be larger. For example,  $A_2$  may be made slightly larger to compensate for tolerances in the manufacturing process, errors in aligning separate optical device 10 with LED 15 or other factors.

[0043] In the case where  $A_2$  is made larger than the value determined by equation 1, flux will be conserved, but exitance (defined as flux per unit area) will be reduced from the maximum attainable value.

[0044] To save space, however, it is preferable that  $A_2$  be as small as possible. For example,  $A_2$  is preferably within 5% of the minimum area needed to conserve radiance within 5%. If some light power (luminous flux) may be sacrificed,  $A_2$  can be smaller than the size dictated by conservation of radiance. Furthermore, the shape of exit surface 55 may be different than that of entrance surface 50, so long as the area meets the requirements discussed above.

[0045] The distance between entrance surface 50 and exit surface 55 of separate optical device 10--referred to as the "height" herein, though the distance may extend in other directions than the vertical--may be selected to reduce or minimize TIR of light rays traveling directly from entrance surface 50 to exit surface 55. TIR occurs when light is incident on the surface with an angle of incidence greater than critical angle, which is defined by:

$$n_1 \cdot \sin(\theta_c) = n_2 \sin(90) \quad \text{EQN. 2}$$

where  $n_1$  = IOR of separate optical device;

$n_2$  = IOR of substance external to the exit of separate optical device 10 (e.g., air or other substance); and

$\theta_c$  = the critical angle.

For example, if  $n_1 = 1.5$  and  $n_2 = 1$ , then  $\theta_c \approx 41.81$  degrees. Accordingly, the height of separate optical device 10 can be selected to limit the critical angle of rays incident on exit surface 55 to a range between normal to exit surface 55 and less than or equal to the critical angle.

[0046] Referring briefly to FIGURES 2 and 3, FIGURE 2 is a diagrammatic representation of a set of rays traveling from point 57 incident on a surface 55 (represented as surfaces 55a, 55b and 55c at different distances from point 57). In the example of surface 55a, some rays (e.g., ray 56) are incident on surface 55a at greater than the critical angle, causing loss of light due to TIR. In the example of surface 55b, conversely, some rays that would be incident on surface 55c at the critical angle or somewhat less than the critical angle (e.g., ray 57) will instead be incident on the sidewalls. Preventing loss of these rays, if desired, can cause the complexity of the sidewall design to increase. Moreover, the additional height requires more room to accommodate the optical device (i.e., because the optical device is taller). Finally, in the case of surface 55c, rays at or less than the critical angle are incident on surface 55 while rays that would be greater than the critical angle on exit surface 55 instead are incident on the sidewalls. TIR or reflection can be used to direct the rays incident on the sidewalls to exit surface 55 as discussed below.

[0047] The limiting ray for selecting height, according to one embodiment, is the ray that travels the longest straight line distance from entrance surface 50 to exit surface 55 and is incident on exit surface 55 at the critical angle. There may be more than one ray that can be selected as the limiting ray. In a square or rectangular configuration this is the ray that enters separate optical device 10 at a corner of entrance surface 50 and travels in a straight line to the diagonally opposite corner of exit surface 55 such that the ray would be incident on exit surface 55 at the critical angle.

[0048] FIGURE 3 provides a diagrammatic representation of a top view of a separate optical device 10 and of limiting ray 59 for a square configuration. While, in the preferred embodiment, the height of separate optical device 10 is selected to limit the critical angle of rays incident on exit surface 55 to a range of between normal to exit surface 55 and to less than or equal to the critical angle, other heights can be selected, though the use of other heights may decrease the efficiency of separate optical device 10. Preferably, the distance between the entrance surface and exit surface is within 5% of the minimum height that causes all rays with a straight transmission path from the entrance surface to the exit surface to

have an angle of incidence on the exit surface at less than or equal to the critical angle.

- [0049] Returning to FIGURE 1, with selected boundary conditions of the size and shape of entrance surface 50, size and shape of exit surface 55, size and distance between entrance surface 50 and exit surface 55, the sidewalls (e.g., sidewall 60, sidewall 65 and other sidewalls) of separate optical device 10 can be shaped to direct light incident on the inner side of the sidewalls to exit surface 55 to produce a desired intensity profile. While, for most applications the desired intensity profile is uniform or close to uniform, other distribution profiles can be achieved by varying the height and shapes of the sidewalls. It should be noted that for the case of an ideal emitter having a uniform lambertian emission pattern, and for an optical device having the minimum calculated surface area per EQUATION 1, and a uniform radiant intensity distribution at the exit face, then the etendue equation REQUIRES the distribution of the exitance at the exit face to also be uniform. If an exitance profile other than a uniform one is desired, then the output face area must be larger than that calculated with EQN. 1. In no case is it possible for any elemental area of the output face to have a radiance greater than the radiance of the source.
- [0050] Broadly speaking, the sidewall shapes are determined so that any ray incident on a sidewall is reflected to exit surface 55 and is incident on exit surface 55 at the critical angle or less (i.e., so that there is no loss due to internal reflection at exit surface 55). This is shown in FIGURE 1 by ray 70 that has angle of incidence 75 relative sidewall 65 that is greater than  $\theta_c$  so that ray 70 is reflected to exit surface 55 and has an angle of incidence 80 that is less than or equal to  $\theta_c$ . While, preferably, the sidewalls are shaped so that all rays that encounter the inner surface of the sidewalls experience total internal reflection to exit surface 55 and are incident on exit surface 55 at the critical angle or less, other sidewall shapes that allow some loss can be used.
- [0051] FIGURE 4A is a diagrammatic representation of a cross-section of a model of a separate optical device for determining sidewall shapes. Sidewall shapes can be determined using computer-aided design. A model of the sidewall can be created in a computer-aided design package and simulations run to determine an appropriate sidewall shape.
- [0052] According to one embodiment, each sidewall can be divided into n facets with each facet being a planar section. For example, sidewall 100 is made of fifteen planar facets 102a-102o rather than a continuous curve. The variables of each

- 11 -

facet can be iteratively adjusted and the resulting distribution profiles analyzed until a satisfactory profile is achieved as described below. While the example of fifteen facets is used, each sidewall can be divided into any number of facets, including more than thirty facets.

- [0053] Each facet can be analyzed with respect to reflecting a certain subset of rays in a separate optical device. This area of interest can be defined as an "angular subtense." The angular subtense for a facet may be defined in terms of the angles of rays emanating from a predefined point. Preferably, the point selected is one that will give rays with the highest angles of incidence on the facet because such rays are the least likely to experience TIR at the facet. In a square separate optical device, for example, this will be a point on the opposite edge of the entrance surface.
- [0054] According to one embodiment, for a selected  $A_1$ ,  $A_2$ , and height, the maximum of angle 95 of any ray that will be incident on a given sidewall (e.g., sidewall 100) without being previously reflected by another sidewall can be determined. In this example, ray 110 emanating from point 115 establishes the maximum angle 95 for sidewall 100. If the maximum of angle 95 is 48 degrees and there are 15 facets for sidewall 100, each facet (assuming an even distribution of angular subtenses) will correspond to a 3.2 degree band of angle 95 (e.g., a first facet will be the area on which rays emanating from point 115 with an angle 95 of 0-3.2 degrees are incident, the second facet will be the area on which rays emanating at point 115 with an angle 95 of 3.2-6.4 degrees are incident and so on).
- [0055] For each facet the exit angle, facet size, tilt angle, or other parameter of the facet can be set so that all rays incident on the facet experience TIR and are reflected to exit surface 55 such that they are incident on exit surface 55 with an angle of incidence of less than or equal to the critical angle. Preferably, the sidewalls are also shaped so that that a ray viewed in a cross-sectional view only hits a side wall once. However, there may be third dimension reflection from a sidewall out of plane of the section. For a full 3D analysis, a ray that strikes a first sidewall near a corner, may then bounce over to a second side wall, adjacent to the first, and from there to the exit face. A curve fit or other numerical analysis may be performed to create a curved sidewall shape that best fits the desired facets. In FIGURE 4A, for example, sidewall 105 is curved rather than a set of planar facets.
- [0056] To optimize the variables for each facet, a simulated detector plane 120 can be established. Detector plane 120 can include x number of detectors to

independently record incident power. A simulation of light passing through the separate optical device may be performed and the intensity distribution as received by detector plane 120 analyzed. If the intensity distribution is not satisfactory for a particular application, the angles and angular subtenses of the facets can be adjusted, a new curved surface generated and the simulation re-performed until a satisfactory intensity profile is reached. Additional detector planes can be analyzed to ensure that both near field and far field patterns are uniform. Alternatively, the simulation(s) can be performed using the facets rather than curved surfaces and the surface curves determined after a desired intensity profile is reached. In yet another embodiment, the sidewalls can remain faceted and no curve be generated.

[0057] FIGURE 4B is a diagrammatic representation illustrating that the facets for a sidewall can be defined using a computer program such as Microsoft Excel (Microsoft and Excel are trademarks of Redmond, Washington-based Microsoft Corporation). The graphing feature in Microsoft Excel can be used to create a graph, shown at 125, of a sidewall shape. The same general shape can be used for each sidewall or different shapes for different sidewalls. A separate optical device with the specified sidewall shape (or with a curved sidewall shape based on the specified facets) can be analyzed in, for example, Zemax optical design program (Zemax is a trademark of Zemax Development Corporation of Bellevue, Washington). A computer simulation can be conducted in Zemax to generate a ray trace and an intensity and irradiance distribution profile. If the resulting intensity and irradiance profile has an unsatisfactory distribution or the efficiency of the separate optical device is too low, the variables of the various facets can be adjusted and the simulations performed again. This process can be automated through the use of a computer program to automatically adjust facet variables.

[0058] When a satisfactory efficiency and intensity profile are achieved, a separate optical device can be formed having the specified parameters. An example of such a separate optical device is shown in FIGURE 4C which provides a diagrammatic representation of one embodiment of separate optical device 10 with sidewalls shaped to cause TIR so that rays are reflected from the sidewalls to the exit surface. The shape of each sidewall, in this embodiment, is a superposition of multiple contoured surfaces as defined by the various facets. While a curve fit is performed for ease of manufacturability, other embodiments of the present invention can retain faceted sidewalls.

[0059] As described above, various boundary conditions, particularly the area of exit surface 55, are determined for the separate optical device so that brightness is conserved. The minimum area of exit surface 55 can be determined from EQN. 1 above, which relies on various effective solid angles. Typically, the effective solid angle of light is determined based on equations derived from sources that radiate as Lambertian emitters, but that are treated as points because the distances of interest are much greater than the size of the source. The observed Radiant Intensity (flux/steradian) of a Lambertian source varies with the angle to the normal of the source by the cosine of that angle. This occurs because although the radiance (flux/steradian/m<sup>2</sup>) remains the same in all directions, the effective area of the source decreases to zero as the observed angle increases to 90 degrees. Integration of this effect over a full hemisphere results in a projected solid angle value equal to  $\pi$  steradians.

[0060] Turning to FIGURE 5, assume a sphere 130 of given radius (R) surrounds the point source 132. The area A<sub>3</sub> can be calculated as the flat, circular surface (e.g., surface 136) that is subtended by the beam solid angle of interest using a radius of the circle 134 (R<sub>c</sub>) that is the distance from the normal ray to the intersection of the spherical surface. For a given half angle 137 of  $\theta$  of the beam, R<sub>c</sub> is the product of R (the radius of the sphere) and the sine of the angle  $\theta$ , such that

$$R_c = R \cdot \sin(\theta) \quad \text{[EQN. 3]}$$

The area equals:

$$A_3 = \pi R_c^2 = \pi (R \cdot \sin(\theta))^2 \quad \text{[EQN. 4A]}$$

The area A<sub>3</sub> is the projected area of the solid angle as it intersects the sphere. The area A<sub>3</sub> is divided by the projected area of the hemisphere (A<sub>h</sub> =  $\pi R^2$ ) and the quotient is multiplied by the projected solid angle of the full hemisphere (equal to  $\pi$ ) to obtain the projected solid angle  $\Omega$ , such that:

$$\Omega = \pi \{ \text{projected area of desired solid angle} / (\text{projected area of hemisphere}) \} \quad \text{[EQN. 4B]}$$

$$\Omega = (\pi) * [ (\pi (R \cdot \sin(\theta))^2) / (\pi R^2) ] \quad \text{[EQN. 4C]}$$

$$= \pi * \sin^2(\theta) \quad \text{[EQN. 5]}$$

[0061] For entrance surface 50,  $\theta$  is approximately 90 degrees, leading to a projected solid angle of  $\pi * \sin^2(90) = \pi$  and for the desired half angle of 30 degrees, the projected solid angle is  $\pi * \sin^2(30) = \pi/4$ . Using these values for  $\Omega_1$  and  $\Omega_2$  for EQN. 1, A<sub>2</sub> can be determined for the desired half angle of 30 degrees.

- [0062] In the above example, the effective solid angle is determined using equations derived from a point source. These equations do not consider the fact that LED 15 may be square, rectangular or otherwise shaped. While this method can give a good estimate of  $A_2$ , which can be later adjusted if necessary based on empirical or computer simulation testing, other methods of determining effective solid angle can be used.
- [0063] FIGURES 6A-6E describe another method for determining effective solid angle for a separate optical device that attaches to an LED that more accurately accounts for the square profile of the typical separate LED. FIGURE 6A is a diagrammatic representation of one embodiment of an entrance face 150 and an exit face 155 of a separate optical device 160 (shown in FIGURE 6B) and a hypothetical target plane 156 onto which light is projected. For purposes of further discussion, it is assumed that the center of entrance face 150 is at 0,0,0 in a Cartesian coordinate system. Target plane 156 represents the parameters of the resulting pattern (e.g., size and half angle used by other optics). According to one embodiment, the half angle at the diagonal (shown as  $\alpha_1$  in FIGURE 6B) is the starting point. For example, if the desired light at target plane 156 has a maximum half angle of 30 degrees,  $\alpha_1$  for a square- or rectangular-faced separate optical device is 30 degrees. The half-angle within separate optical device 160 (labeled  $\beta_1$  and also shown in FIGURE 6C) can then be determined according to:
- $$n_2 \sin(\alpha_1) = n_1 \sin(\beta_1) \quad [\text{EQN. 6}]$$
- where  $n_1$  is the IOR of the separate optical device;  
 $n_2$  is the IOR of the material (typically air) into which the light is projected from the separate optical device;  
 $\theta_1$  is the half angle in the LED material (typically 90 degrees);  
 $\beta_1$  is the desired half angle in the separate optical device.
- [0064] For example, if the desired half-angle  $\alpha_1$  is 30 degrees, and a separate optical device having an IOR of 1.5 is projecting into air having an IOR of 1, then  $\beta_1 = 19.47$  degrees. A similar calculation can be performed for a ray projecting from a point on the long and short sides of entrance surface 150. For example, as shown in FIGURES 6B and 6C,  $\alpha_2$  and  $\beta_2$  can be determined for a ray traveling from the center of one edge on entrance surface 150 to the center of the opposite edge of exit surface 155. (The critical angle is the same at 19.47, but  $\beta_1$  is not the same as  $\beta_2$ .  $\beta_2$  is determined by the geometry of the sides and the height to the optical device.)

[0065] Using the angles calculated, the location of an effective point source 157 can be determined. For a square entrance face 150, of length  $l_1$ , the effective point source will be located  $X=0, Y=0$  and

$$Z_{eps} = \frac{l_1}{\sqrt{2} * \tan(\beta_1)} \quad \text{[EQN. 7]}$$

Where  $z_{eps}$  is the distance the effective point source is displaced from the emitting surface of the LED.

[0066] The X, Y and Z distances from the effective point source 157 to points  $F_1$  and  $F_2$  can be calculated assuming  $F_1$  intersects a sphere of unity radius according to:

$$X_{F1} = \cos(\psi_1) \sin(\beta_1) \quad \text{[EQN. 8]}$$

$$Y_{F1} = \sin(\psi_1) \sin(\beta_1) \quad \text{[EQN. 9]}$$

$$Z_{F1} = \cos(\beta_1) \quad \text{[EQN. 10]}$$

$$X_{F2} = \cos(\psi_2) \quad \text{[EQN. 11]}$$

$$Y_{F2} = \sin(\beta_2) \quad \text{[EQN. 12]}$$

$$Z_{F2} = \cos(\beta_2) \quad \text{[EQN. 13]}$$

[0067] where  $\psi_1$  is the angle of the diagonal ray in the X-Y plane (45 degrees for a square) and where  $\psi_2=90$  degrees for a ray projecting from the middle of a side parallel to the X axis as shown in FIGURE 6C. A similar methodology based on the geometries previously calculated can be used to determine other points (e.g., for example, the location of points  $T_1$  and  $T_2$  can be determined based on the location of points  $F_1$  and  $F_2$  and the desired half angle of light at target plane 156.)

[0068] FIGURE 6D illustrates the diagonal rays and one ray from the short side projected onto a sphere 159 for exit face 155 and sphere 161 for target plane 156. For exit face 155, the projection of the intersection of the edge rays at the sphere 159 onto the plane of the exit face 155, forms elliptical segments. Likewise, the projection of the diffracted exit rays at the edge of the target face intersect the sphere 161. FIGURE 6E, for example, points out the circular intersection of the rays lying in the plane formed by the edge 163 of target face 156 intersecting sphere 161, and the projection of that intersection onto the target plane 156. By calculating the area of each of the elliptical segments surrounding the square of the target face, and adding that to the area of the target face we find the total projected area of the target face. the effective solid angle can be determined for the target plane using Eqn 4B. Similarly, by using sphere 159 and the elliptical segments formed thereon by rays, the effective solid angle for the optical device can be determined. For example, the total projected area is



- 16 -

determined as described above and inserted as "projected area of desired solid angle" in equation 4B.

- [0069] As one illustrative example, using the above method for a half-angle of 30 degrees with a square LED and output face yields an effective solid angle of 0.552 steradians to the target in air. By contrast, the use of the traditional circular projected area with a 30 degree half angle would yield an effective solid angle of 0.785 steradians. When these values are then used in EQUATION 1, for given IORs and flux, the traditional (circular) calculation yields a required exit area that is undersized by about 30%. If one were to design a system using this approach, the applicable physics (conservation of radiance) would reduce the light output by 30% over the optimum design. Conversely, using the corrected effective solid angle described above calculates an exit face area that will produce 42% more light output than is achievable with the circular calculation.
- [0070] Although particular methods of determining the effective solid angle for a separate optical device are described above, any method known or developed in the art can be used. Alternatively, the minimum surface area to conserve brightness can be determined empirically. Moreover, while the minimum surface area calculations above assume 100% of the emitting surface of the LED is emitting, in real life devices, less than 100% of the emitting surface area may be emitting and the distribution may be uneven. The calculations of the minimum area of the exit surface can be adjusted to account of the actual emitting area of the LED, rather the size of the entrance surface. That is, the actual emitting area of the LED can be used as  $A_1$ .
- [0071] Separate optical devices according to embodiments of the present invention can project light into a desired cone angle of 10-60 degrees with a theoretical efficiency of up to 96% (meaning that 96% of the light received from the LED is emitted in the desired half-angles with 4% fresnel loss). The efficiency can be 100% without fresnel losses. Even at only 70% efficiency, embodiments of the present invention provide greater efficiency than other LED technologies, while also producing uniform or near uniform intensity distributions at both near and far fields.
- [0072] Advantages of the present invention can easily be seen when compared to previous LED solutions. For a straight encapsulation (e.g., a square or cube encapsulation with straight vertical sidewalls), the effective solid angle at the entrance and exit are the same. Assuming an index of refraction of 1.5 for the separate optical device material and 1 for air, approximately 66% of light does not

- 17 -

leave the surface opposite the entrance surface due to TIR. Consequently, a straight walled separate optical device only provides about 44% efficiency in the amount of light emitted out the surface opposite the entrance surface.

Furthermore, secondary optics are needed to shape the light into the desired half angle.

[0073] While a dome optical device used on typical LEDs exhibits higher efficiency, there is still light loss due to TIR, and the emitted light is distributed over the dome surface in ray patterns that are not readily usable for most applications. Secondary collection mechanisms such as lenses or reflectors are therefore required to shape the emitted light into a usable angle.

[0074] Another advantage provided by embodiments of the present invention is that multiple separate optical devices can be easily arranged into an array that provides light in a desired angle (e.g., into an  $f/1$  cone) with a substantially uniform intensity distribution. FIGURE 7 shows one example of a view of an array of separate optical devices 200. The footprint of the entrance surfaces and exit surfaces of the separate optical devices are shown (e.g., entrance surface 205 and exit surface 210). One advantage of using an array of separate optical devices (and corresponding array of LEDs) is that the separate optical devices making up array 200 can be shorter in height than a single separate optical device having the same combined exit surface area and entrance surface area. Consequently, the same amount of light can be transmitted with the same half angle using a smaller amount of overall volumetric space. Furthermore, such a system may be more efficient overall because smaller LEDs tend to be more efficient than larger LEDs (i.e., an array of smaller LEDs can be more efficient than a larger LED with the same light emitting surface area). Arrays of LEDs with corresponding separate optical devices can be arranged to light large areas or long linear surfaces.

[0075] Embodiments of the present invention can be used in a variety of applications. One potential application is in a digital light processing ("DLP") system. In many DLP systems, the DLP chip has an acceptance angle of somewhere between 10 and 12 degrees half angle. The area of the chip multiplied by the acceptance angle sets the etendue of the system. A lighting system that does not match this etendue is wasting light. In previous systems using CPCs, light from an array of multiple LEDs is directed through dichroic filters, to a condenser optic, to an integrating tunnel, to an imaging relay objective and then to the cone. The integrating tunnel is needed to create uniform output.

[0076] FIGURE 8, on the other hand, is a functional diagrammatic representation of a DLP system 300 using separate optical devices combined with LEDs (illustrated together as 305) according to embodiments of the present invention. Assume the DLP system uses three arrays of 12 LEDs each (12 green LEDs, 12 red LEDs and 12 blue LEDs) (the separate optical devices combined with LEDs are represented generally at 305 and not all are shown for the sake of simplicity). Each LED can have an individual separate optical device. For a DLP system using separate optical devices and LEDs 305 according to the present invention rather than CPCs with LEDs, uniform light in the desired f/1 cone (represented at 310) can be projected through the dichroic filters 315 directly to the imaging relay optic 320 and then to DLP chip 325 within the specified acceptance angle. Moreover, the separate optical devices can be shaped so that the projected light has a preferred aspect ratio, such as 4:3, while conserving luminance. This has at least two advantages. First, space is saved because separate optical devices 305 can be generally smaller than CPCs and the distance of the transmission path is smaller as the condenser optic and integrating tunnel are no longer needed. Moreover, the efficiency of the system is increased as there are no light losses due to the condenser optic and integrating tunnel.

[0077] As with DLP system 300, separate optical devices according to various embodiments of the present invention can be used with secondary condensing lenses at the exit face of the separate optical device or away from the exit face of the separate optical device. According to one embodiment, when the condenser lens is away from the exit face of the separate optical device, the focal plane of the condenser lens can be approximately at the exit face of the separate optical device. The condenser lens can be a fresnel lens of TIR and/or refraction design, or other condenser lens. The combination of separate optical device and condenser lens allows the ability to take a Lambertian source with a broad emission solid angle ( $\square$  steradians) and convert it into a narrow solid angle (on the order of 0.1 steradians or less) while conserving radiance of the system and doing so in a very small volume.

[0078] Another potential application for embodiments of the present invention is cell phone display lighting. Present systems typically use three side-emitting blue LEDs with phosphor-filled encapsulant material to generate white light. The sides of the LED are typically opaque and a large percentage of the light generated is absorbed by the sidewalls. This results in over 50% of the light being lost to absorption. In addition, the index change at the interface of the encapsulant to

air creates a TIR condition for exit rays striking the interface at greater than the critical angle. This results in approximately 44% loss at the interface. Separate optical devices, according to various embodiments of the present invention, on the other hand, can deliver up to 95% of the generated light to the light guide, resulting in very large system brightness improvements.

[0079] Phosphors and other materials including nanoparticles of various materials (collectively referred to simply as "phosphors" herein) are commonly used in conjunction with various colors of LEDs to produce white light. According to various embodiments, the LED may also be coated with a phosphor layer between the LED and the separate optical device; or, a phosphor layer can be present between the separate optical device and the subsequent optical element, such as a light guide; or, a phosphor coating may be imbedded in the material of the separate optical device; or, other embodiments of phosphor layering as well. In the first case, all rays from the phosphor-coated LED can be delivered to the light guide. In the second case, all rays from the LED can be delivered to the phosphor layer, and light rays backscattered from the phosphor layer can be recycled. In the third embodiment, light scattered from the phosphor is recycled back in one direction and gets refracted back to the light guide in the other direction. Other embodiments present similar opportunities for capturing and recycling scattered light from the phosphor.

[0080] Another potential application for embodiments of separate optical devices is use as a cell phone camera flash. Present systems typically use LEDs with Gaussian energy distributions that produce a very bright area in the center of the image and dark areas at the edges, causing uneven lighting of the subject matter. Moreover, the beam shape of present flash units is circular, while the image captured by the CCD camera is rectangular. Additionally, the index of refraction change at the interface of the encapsulant to air creates a TIR condition for exit rays striking the interface at greater than the critical angle. This results in losses at the interface that are a function of the exit solid angle. Separate optical devices according to embodiments of the present invention, on the other hand, can deliver a rectangular or square flash, with 95% of the light received by the separate optical device from the LED being provided to the image area in a uniform distribution. This results in more uniform scene illumination and higher levels of illumination from the same LED as used in traditional systems.

[0081] Another potential application for separate optical devices according to embodiments of the present invention is for liquid crystal display ("LCD")

backlighting. Traditional LCD systems use a linear array of red, green and blue LEDs. The light from the LEDs is directed into a mixing light guide to provide uniformity of color and intensity. Typically, the LEDs have a dome placed over the LED and light is captured by elliptical reflectors to direct the light to the light guide. While elliptical reflectors work well for point sources, LEDs are not point sources and some of the rays will not get to the focii inside the light guide (approximately 20% of the light is lost). Moreover, since some light from a dome encapsulant is emitted at greater than 180 degrees, some of the light (again, approximately 20%) is absorbed by the substrate, PCB board and other components. Furthermore, because the dome is large with respect to the size of the cavity in the dome, a certain percentage of light typically gets refracted (typically around 10%). Though all these losses are relatively small, they are multiplicative. Thus, only about 57% of the light originally emitted from the LED actually gets to the light guide.

[0082] Separate optical devices according to embodiments of the present invention, on the other hand, can provide up to 96% of the light received from the LEDs (e.g., red, green and blue LEDs) to the light guide (assuming about 4% Fresnel losses) in the desired cone angle. Consequently, lower power LEDs can be used to achieve the same results as are possible in current systems or more light can be delivered at the same power consumption level. Indeed, in some embodiments, the light guide may not be required and arrays of LEDs with separate optical devices may be used to directly backlight LCDs.

[0083] For lighting purposes (e.g., for LCDs or other applications), red, green and blue LEDs can be used to produce white or other color balanced light as is known in the art. An array of LEDs (e.g., one red, one blue and two green or other combinations) and corresponding separate optical devices can be used to produce white or color balanced light for illumination. According to other embodiments, a single separate optical device can be coupled to an array of multiple LEDs to produce white light. For example, a single separate optical device can be used for a tightly spaced array having one red, one blue and two green LEDs to produce white and color balanced light.

[0084] Another potential use for separate optical devices according to various embodiments of the present invention is in car headlights, flashlights and other devices. The various parameters of the separate optical devices can be selected to provide the desired projection cone and beam profile.

- [0085] FIGURE 9 is a diagrammatic representation of another embodiment of a separate optical device 400 in which separate optical device 400 extends down the sides of LED 405, which fits in a cavity or empty volume defined at the bottom of separate optical device 400. The advantage of extending down all or a portion of the sides of LED is that light rays that would be lost due to TIR in LED sapphire layer 415 at the sapphire/air interface may now enter separate optical device 400. These rays can be reflected by the sidewalls of separate optical device 400 to exit interface 420 as described above (e.g., by shaping the sidewalls to cause TIR). When the sides of LED 405 also become an emitting surface,  $A_1$  and  $A_2$  of separate optical device 400 can be calculated to consider the sides in addition to the top surface of LED 405 (i.e.,  $A_1$  will include the surface areas of entrance surface 430, 435, 440 and other entrance surfaces, not shown). According to other embodiments,  $A_1$  can simply be considered for entrance surface 430 and the size of  $A_2$  calculated and then adjusted slightly to account for the additional light entering entrance surfaces 435, 440 and other entrance surfaces.
- [0086] Separate optical device 400 can be coupled to LED 405 using a polymer or other material that has a similar or identical IOR as separate optical device 400. When separate optical device 400 is placed over LED 405, the polymer or other material can act to completely fill the air spaces between separate optical device 400 and LED 405. If excess material is pressed out from the joint of the separate optical device 400 and LED 405, the material can be removed while still fluid to retain the shape of light directing sidewall surfaces of separate optical device 400.
- [0087] Separate optical device 400 may be substantially larger than LED 405. Consequently, additional support may be required to secure it against vibration, shock and external force. Accordingly, a mechanical attachment device 443 (e.g., of molded plastic, metal or other material) can contact exit face 420 or other parts of separate optical device 400 and attach to supporting structure 445 or the PCB board to create a normal force to keep separate optical device 400 seated against LED 405. Sideways motion can be prevented by frictional force between attachment device 443 and exit face 420 or by other forces between attachment device 443 and separate optical device 400. Preferably, attachment device 443 has the same IOR as separate optical device 400 so that rays exiting separate optical device 400 are not deviated as they pass through attachment device 400. In one embodiment, separate optical device 400 and attachment device 430 can be a single piece, but in other embodiments they can be separate pieces and have different IORs. If attachment device 430 and separate optical device 400

are separate, they can include interlocking locating features such as bumps or ridges for more secure and accurate alignment of the devices. An attachment device 443 can be used in lieu of or in addition to bonding. Attachment device 443 can include a face 446 such as a lens, layer of material or other face through which light exiting exit surface 420 passes. Consequently, attachment device can additionally act to shape or further define the output beam. Though attachment device 443 is shown illustratively in FIGURE 9 (which shows one embodiment of separate optical device 400 with a cavity into which LED 405 fits), attachment device 443 may also be used in conjunction with other embodiments of the separate optical device and LED, including but not limited to the embodiment shown in FIGURE 1 (i.e., a flat-bottomed separate optical device 10 being coupled directly to an LED 15).

[0088] In some cases it can be desirable to have a phosphor (or other material layer) to create white light from LED 405. According to one embodiment, a layer of phosphor can be coated on entrance surfaces 430, 435 and 440 prior to separate optical device 400 being placed over LED 405. According to other embodiments, a phosphor layer can coat exit surface 420 or be embedded in any plane of separate optical device 400 or, as noted above, the phosphor layer can be part of attachment device 443. According to yet another embodiment, a phosphor layer can be external to separate optical device 400 with an air gap between exit surface 420 and the phosphor layer. The sidewalls of separate optical device 400, in this case, can be designed so that light scattered back from the phosphor layer reenters separate optical device 400 and is partially or fully recycled.

[0089] In other cases, the phosphor can be in the bonding polymer. Separate optical device 400 can have a passage 450 running from entrance surface 430 to exit surface 420. Separate optical device 400 can be placed over LED 405 with enough space for an amount of material to be injected. This material, such as a polymer infused with phosphor, can be injected through flow passage 450 to bond separate optical device 400 to LED 405. A clear polymer, or material similar to the material used for the majority of separate optical device 400, can then be injected into flow passage 450 to make separate optical device 400 solid (i.e., to fill flow passage 450).

[0090] While, as discussed above, the sidewalls of a separate optical device (e.g., separate optical device 10 and separate optical device 400) can be shaped so that light incident on the inner surface of the sidewalls is reflected to the exit surface due to TIR, other embodiments can rely on reflection by a reflector.

- 23 -

FIGURE 10 is a diagrammatic representation of one embodiment of a separate optical device 500 coupled to an LED 505. Separate optical device 500 includes an exit surface 520 and an entrance surface 530. In the example of FIGURE 10, the sidewalls of separate optical device 500 (e.g., sidewall 540 and sidewall 545) can include a reflective coating 550 that can be formed of any suitable reflective material such as nickel or aluminum. The sidewall shapes can be selected to rely on reflection from reflective coating 550 to reflect all or most rays incident on the sidewalls to exit surface 520. While there may be some losses due to absorption that would not be present using TIR, the use of a reflective coating may be less complex from a manufacturing standpoint. Additionally, using reflective surfaces eliminates the need to have the rays strike the sidewalls at angles greater than the critical angle, allowing more freedom in the design of the sidewall shapes.

[0091] In some applications, stacked separate optical devices can be used. FIGURE 11 is a diagrammatic representation of one embodiment of stacked separate optical devices including separate optical device 560 and separate optical device 565. According to one embodiment, a layer of phosphor (or other material as previously discussed) can be disposed between the exit surface of separate optical device 560 and the entrance surface of separate optical device 565. Layer of phosphor 570 can include, for example, a layer of a polymer material imbedded with phosphor. The polymer material can extend beyond the edges of the exit surface of separate optical device 560 and include attachment mechanism (e.g., legs or other mechanisms) that can attach to PCB, a supporting substrate or other base. In this case, the layer of polymer material is part of an attachment device, such as that described above. In other embodiments, other types of material or no material is disposed between the separate optical devices.

[0092] According to one embodiment, separate optical device 560 can have a higher IOR and separate optical device 565 can have a lower IOR, or vice versa. In other embodiments, separate optical device 565 and separate optical device 560 can have the same IOR.

[0093] FIGURE 12 is a diagrammatic representation of another embodiment of a separate optical device 600. For separate optical device 600, the height (the distance between entrance surface 605 and exit surface 610) varies depending on the skew angle  $\theta_s$  619 of the cross section at that point.  $\theta_s = 0$  corresponds to a cross section taken across the separate optical device from the middle of one side to the middle of the opposite side. This is represented at 620 while a skew angle of 45 degrees is represented at 622. According to one embodiment the



maximum height for a square separate optical device (e.g., determined as described above) occurs at the cross sections having  $\theta_s = 45 \pm n \cdot 90$  degrees where  $n$  is an integer. In other words, the maximum height occurs at the diagonals (represented at 622). The minimum height occurs at  $\theta_s = 0 \pm n \cdot 90$ . Other embodiments of variable height separate optical devices can also be formed.

[0094] Separate optical devices can be formed in a variety of manners. For example, an array of partially completed separate optical devices comprising the sidewalls and end surface defining a cavity can be molded in a continuous array (e.g., appearing similar to an egg crate). This can be done, for example, by injection molding. The array can then be placed over a corresponding array of LEDs and the volume inside the cavities filled with dielectric material. The sidewalls of the array optionally can be coated with a reflective material. In another embodiment, the array can be formed by vacuum forming of a thermoplastic sheet, draw-die forming of a metallic sheet (which may be the reflective coating the completed separate optical device) or other suitable method known or developed in the art. Again, the array can be placed over the corresponding LEDs and the cavities filled with dielectric material to complete the separate optical device.

[0095] In the above embodiments, the separate optical devices are molded in place on top of the LED, but separately from the LED. In another embodiment, the separate optical device can be pre-molded apart from the LED using conventional molding or other techniques. In this case, the separate optical device can include a cavity to receive the LED. The LED and separate optical device, as described above, can be bonded together using a polymer or other bonding agent, can be held together using an attachment device or can otherwise be placed in operational relationship to each other.

[0096] While the present invention has been described with reference to particular embodiments, it should be understood that the embodiments are illustrative and that the scope of the invention is not limited to these embodiments. Many variations, modifications, additions and improvements to the embodiments described above are possible. For example, the various ranges and dimensions provided are provided by way of example and optical devices according to the present invention may be operable within other ranges using other dimensions. It is contemplated that these variations, modifications, additions and improvements fall within the scope of the invention as detailed in the following claims.

WHAT IS CLAIMED IS:

1. A separate optical device operable to couple to a separate LED, the separate optical device comprising:

an entrance surface to receive light from a separate LED when the separate optical device is coupled to the separate LED;

an exit surface opposite from and a distance from the entrance surface, wherein the exit surface has at least a minimum area necessary to conserve radiance for a desired half-angle of light projected from the separate optical device;

a set of sidewalls, wherein each sidewall is positioned and shaped so that at least a majority of rays having a straight transmission path from the entrance surface to that sidewall reflect to the exit surface with an angle of incidence at the exit surface at less than or equal to a critical angle at the exit surface.

2. The separate optical device of Claim 1, wherein the exit surface has the minimum area necessary to conserve brightness for the desired half-angle of light emitted from the separate optical device.

3. The separate optical device of Claim 1, wherein the exit surface has an area that is at least equal to a minimum area equal to  $\frac{\Phi_2 n_1^2 A_1 \Omega_1}{\Phi_1 n_2^2 \Omega_2}$  wherein  $\Phi_1$  is the light flux entering the entrance surface,  $\Phi_2$  is the light flux exiting exit surface,

$\Omega_1$  is the effective solid angle whereby light enters the entrance surface,  $\Omega_2$  is the effective solid angle whereby light leaves exit surface;  $A_1$  is the area of the entrance surface,  $n_1$  is the refractive index of material of the separate optical device and  $n_2$  is the refractive index of the substance external to the separate optical device.

4. The separate optical device of Claim 3, wherein the LED has a square shape and wherein the effective solid angle whereby light leaves the exit surface is determined to account for the square shape of the LED.

5. The separate optical device of Claim 1 wherein the distance is within 50% of a minimum distance so that all rays with a straight transmission path from the entrance surface to the exit surface have an angle of incidence that is less than or equal to the critical angle at the exit surface and wherein the area of the exit surface is within 50% of a minimum area

- 26 -

defined by  $\frac{\Phi_2 n_1^2 A_1 \Omega_1}{\Phi_1 n_2^2 \Omega_2}$  wherein  $\Phi_1$  is the light flux entering the entrance surface,  $\Phi_2$  is

the light flux exiting exit surface,

$\Omega_1$  is the effective solid angle whereby light enters the entrance surface,  $\Omega_2$  is the effective solid angle whereby light leaves exit surface;  $A_1$  is the area of the entrance surface,  $n_1$  is the refractive index of material of the separate optical device and  $n_2$  is the refractive index of the substance external to the separate optical device.

6. The separate optical device of Claim 1, wherein each sidewall is positioned and shaped so that at least 80% of rays with a straight transmission path from the entrance surface to the sidewall are reflected to the exit surface with an angle of incidence on the exit surface at less than or equal to the critical angle at the exit surface.

7. The separate optical device of Claim 6, wherein the at least 80% of rays reflected are reflected through total internal reflection.

8. The separate optical device of Claim 6, further comprising a reflective layer and wherein each sidewall is shaped so that the at least 80% of rays are reflected by the reflective layer to the exit surface with an angle of incidence on the exit surface at less than or equal to the critical angle at the exit surface.

9. The separate optical device of Claim 1, wherein the shapes of the sidewall are selected to create a desired intensity profile.

10. The separate optical device of Claim 8, wherein the desired intensity profile is an approximately uniform intensity profile.

11. The separate optical device of Claim 1, wherein the separate optical device is formed of a single piece of solid material.

12. The separate optical device of Claim 11, wherein the separate optical device has an index of refraction within 20% of the index of refraction of a substrate of the LED.

13. The separate optical device of Claim 1, wherein the entrance surface and exit surface have the same shape and aspect ratio as the LED.

- 27 -

14. The separate optical device of Claim 1, wherein the exit surface is parallel to and rotationally aligned with the entrance surface.

15. The separate optical device of Claim 1, wherein the entrance surface is square.

16. The separate optical device of Claim 1, wherein the separate optical device is configured to output a substantially square and uniform beam of light.

17. The separate optical device of Claim 1, wherein the separate optical device is configured to direct light from the LED into a smaller solid angle while conserving radiance.

18. The separate optical device of Claim 17, wherein the separate optical device is configured to provide a maximum radiant intensity.

19. The separate optical device of Claim 1, wherein the separate optical device defines a set of additional entrance surfaces that at least partially define a cavity into which the LED at least partially fits.

20. A separate optical device operable to couple to a separate LED, the separate optical device comprising:

an entrance surface to receive light from a layer of a separate LED when the separate optical device is coupled to the separate LED;

an exit surface opposite from and a distance from the entrance surface, wherein the exit surface has at least a minimum area necessary to conserve radiance for a desired half-angle of light projected from the separate optical device;

a set of sidewalls, wherein each sidewall is positioned and shaped so that at least a portion of rays having a straight transmission path from the entrance surface to that sidewall reflect to the exit surface with an angle of incidence at the exit surface at less than or equal to a critical angle at the exit surface, wherein each sidewall shape represents a superposition of multiple contoured surfaces;

wherein the area of the exit surface, distance and sidewall shapes are selected to project light with a half angle of between 10 to 60 degrees with at least 70% efficiency and a desired intensity profile.

- 28 -

21. The separate optical device of Claim 20, wherein the area of the exit surface, distance and sidewall shapes are selected to project light with a half angle of between 10 to 60 degrees with at least 90% efficiency

22. The separate optical device of Claim 20, wherein the exit surface has an area that is at least equal to a minimum area equal to  $\frac{\Phi_2 n_1^2 A_1 \Omega_1}{\Phi_1 n_2^2 \Omega_2}$  wherein  $\Phi_1$  is the light flux entering the entrance surface,  $\Phi_2$  is the light flux exiting exit surface,

$\Omega_1$  is the effective solid angle whereby light enters the entrance surface,  $\Omega_2$  is the effective solid angle whereby light leaves exit surface;  $A_1$  is the area of the entrance surface,  $n_1$  is the refractive index of material of the separate optical device and  $n_2$  is the refractive index of the substance external to the separate optical device..

23. The separate optical device of Claim 22, wherein the LED has a square shape and wherein the effective solid angle whereby light leaves the exit surface is determined to account for the square shape of the LED.

24. The separate optical device of Claim 20, wherein the distance is within 50% of a minimum distance so that all rays with a straight transmission path from the entrance surface to the exit surface have an angle of incidence that is less than or equal to the critical angle at the exit surface and wherein the area of the exit surface is within 50% of a minimum area defined by  $\frac{\Phi_2 n_1^2 A_1 \Omega_1}{\Phi_1 n_2^2 \Omega_2}$  wherein  $\Phi_1$  is the light flux entering the entrance surface,  $\Phi_2$  is the light flux exiting exit surface,

$\Omega_1$  is the effective solid angle whereby light enters the entrance surface,  $\Omega_2$  is the effective solid angle whereby light leaves exit surface;  $A_1$  is the area of the entrance surface,  $n_1$  is the refractive index of material of the separate optical device and  $n_2$  is the refractive index of the substance external to the separate optical device.

25. The separate optical device of Claim 20, wherein each sidewall is positioned and shaped so that at least 80% of rays with a straight transmission path from the entrance surface to the sidewall are reflected to the exit surface with an angle of incidence on the exit surface at less than or equal to the critical angle at the exit surface.

26. The separate optical device of Claim 20, further comprising a reflective layer and wherein each sidewall is shaped so that the at least 80% of rays are reflected by the

reflective layer to the exit surface with an angle of incidence on the exit surface at less than or equal to the critical angle at the exit surface.

27. The separate optical device of Claim 20, wherein the separate optical device is formed of a single piece of solid material.

28. The separate optical device of Claim 27, wherein the separate optical device has an index of refraction within 20% of the index of refraction of the layer of the LED.

29. The separate optical device of Claim 20, wherein the entrance surface and exit surface have the same shape and aspect ratio as the LED.

30. The separate optical device of Claim 20, wherein the exit surface is parallel to and rotationally aligned with the entrance surface.

31. The separate optical device of Claim 20, wherein the entrance surface is square.

32. The separate optical device of Claim 20, wherein the separate optical device defines a set of additional entrance surfaces that at least partially define a cavity into which the LED at least partially fits.

33. A separate optical device configured to couple to a separate LED, the separate optical device comprising:

an entrance surface to receive light from a layer of a separate LED when the separate optical device is coupled to the separate LED;

an exit surface opposite from and a distance from the entrance surface:

wherein the exit surface has an area at least equal to a minimum area defined by

$$\frac{\Phi_2 n_1^2 A_1 \Omega_1}{\Phi_1 n_2^2 \Omega_2}$$

wherein  $\Phi_1$  is the light flux entering the entrance surface,  $\Phi_2$  is the light flux

exiting exit surface,

$\Omega_1$  is the effective solid angle whereby light enters the entrance surface,  $\Omega_2$  is the effective solid angle whereby light leaves exit surface;  $A_1$  is the area of the entrance surface,  $n_1$  is the refractive index of material of the separate optical device and  $n_2$  is the refractive index of the substance external to the separate optical device. wherein the distance is selected to be at least a minimum distance so that all rays with a straight transmission path

- 30 -

from the entrance surface to the exit surface have an angle of incidence that is less than or equal to a critical angle at the exit surface;

a set of sidewalls, wherein each sidewall is positioned and shaped so that at least a portion of rays having a straight transmission path from the entrance surface to that sidewall reflect to the exit surface with an angle of incidence at the exit surface at less than or equal to the critical angle at the exit surface, wherein each sidewall shape represents a superposition of multiple contoured surfaces;

wherein the area of the exit surface, distance and sidewall shapes are selected to project light with a half angle of between 10 to 60 degrees with at least 60% efficiency and a desired intensity profile.

34. The separate optical device of Claim 33, wherein the area of the exit surface, distance and sidewall shapes are selected to project light with a half angle of between 10 to 60 degrees with at least 90% efficiency.

35. The separate optical device of Claim 33, wherein the area of the exit surface is within 5% of the minimum area; and the distance is within 5% of the minimum distance.

36. The separate optical device of Claim 33, wherein the LED has a square shape and wherein the effective solid angle whereby light leaves the exit surface is determined to account for the square shape of the LED.

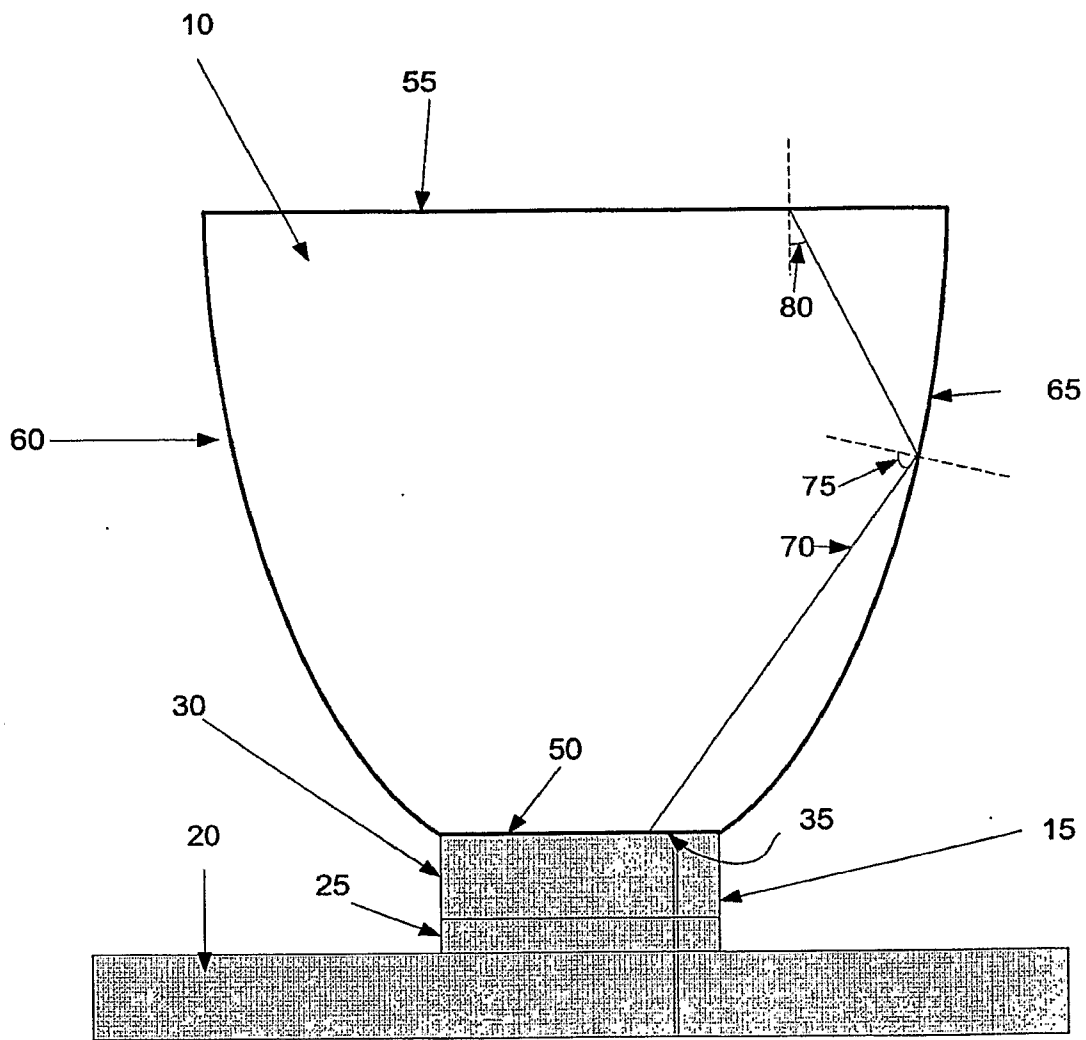

FIGURE 1



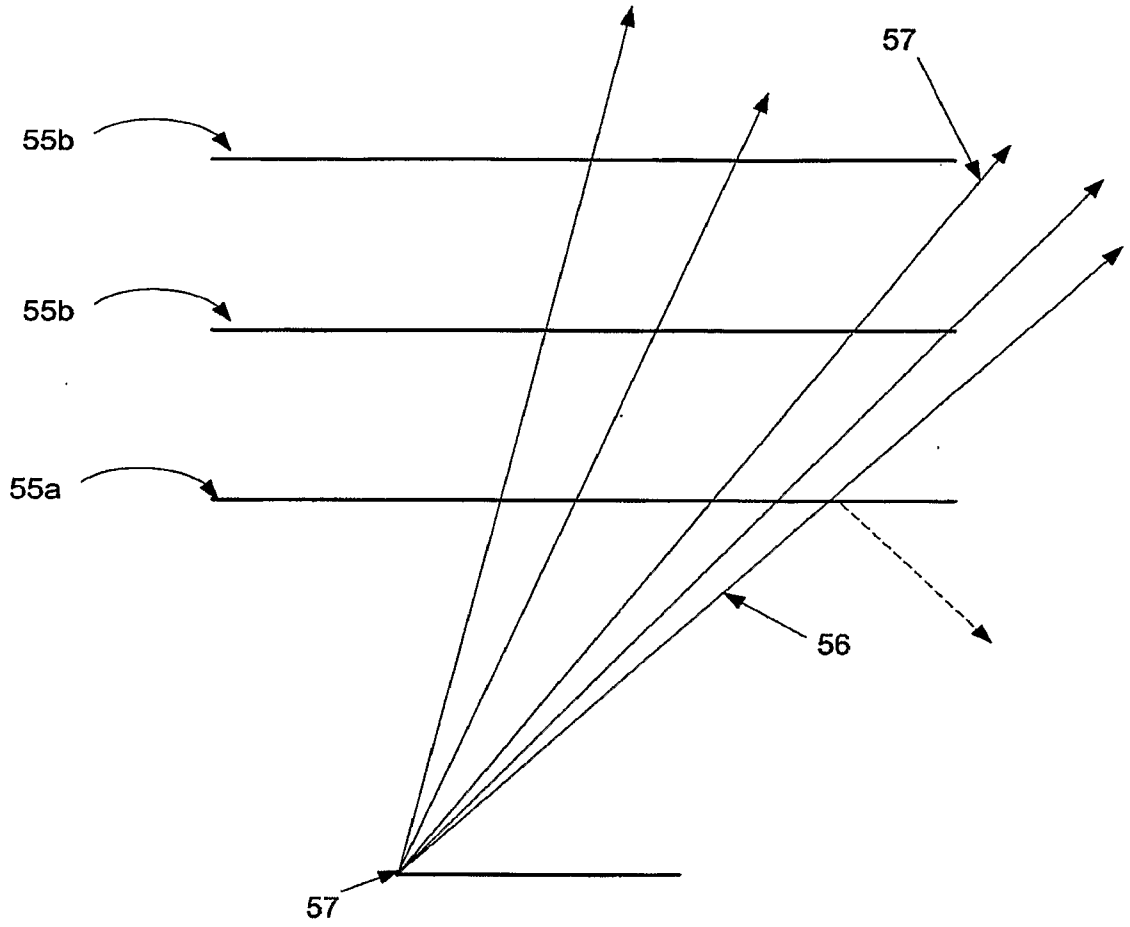

FIGURE 2

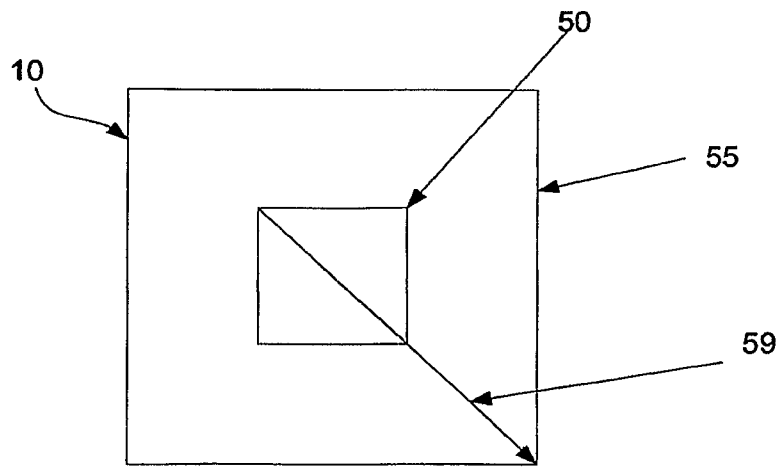

FIGURE 3

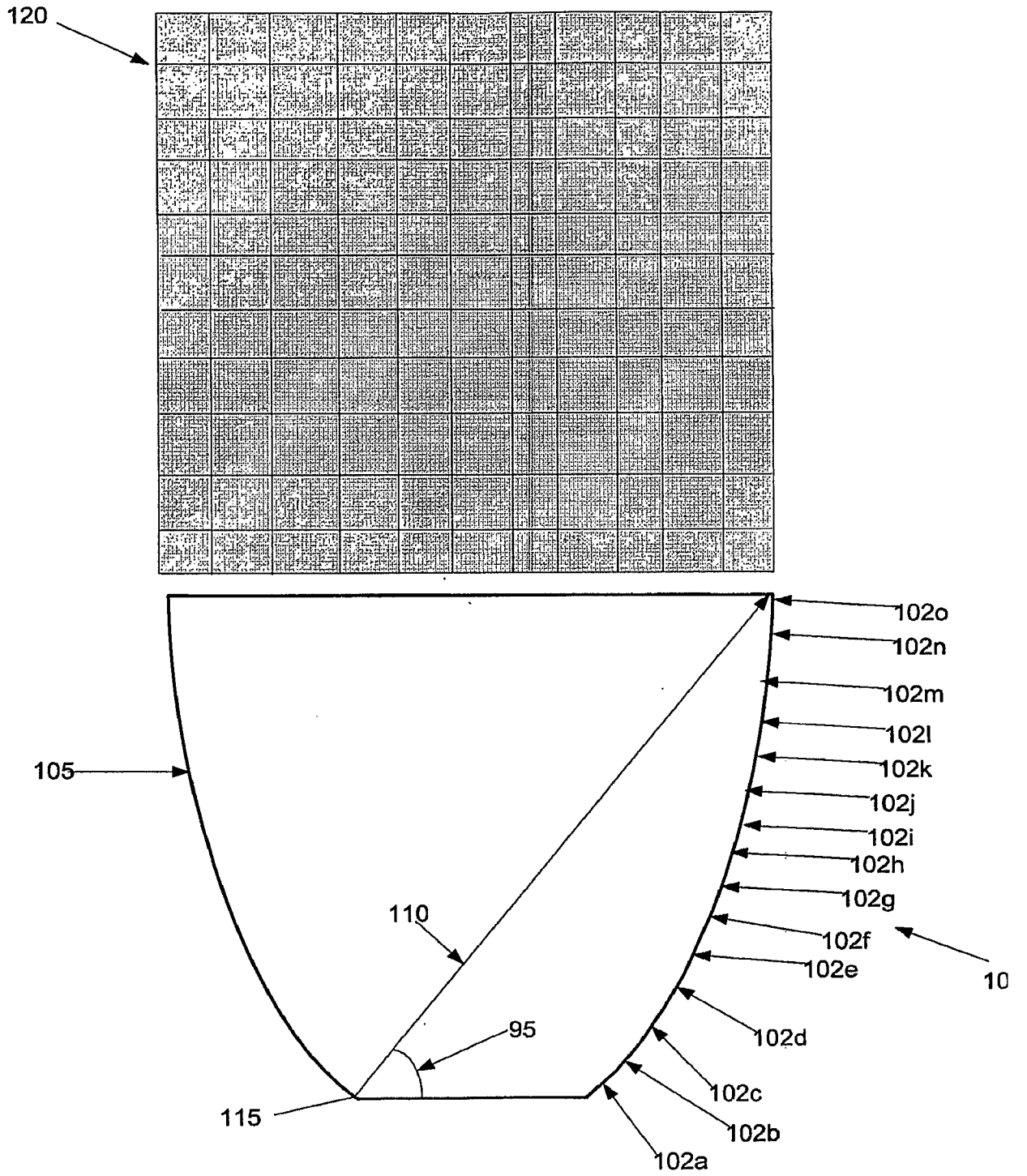

FIGURE 4A

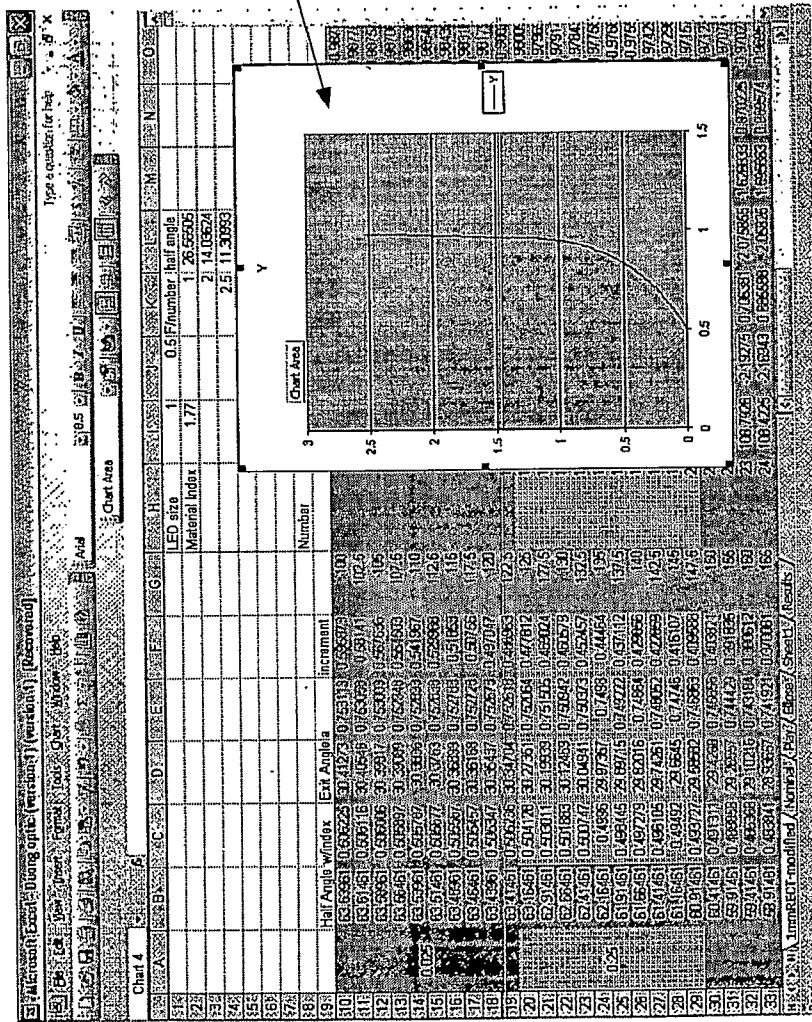

FIGURE 4B

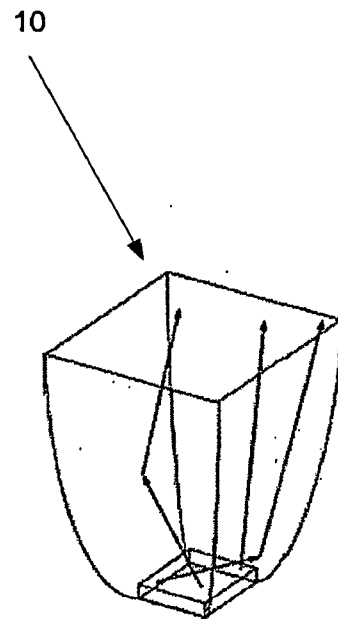
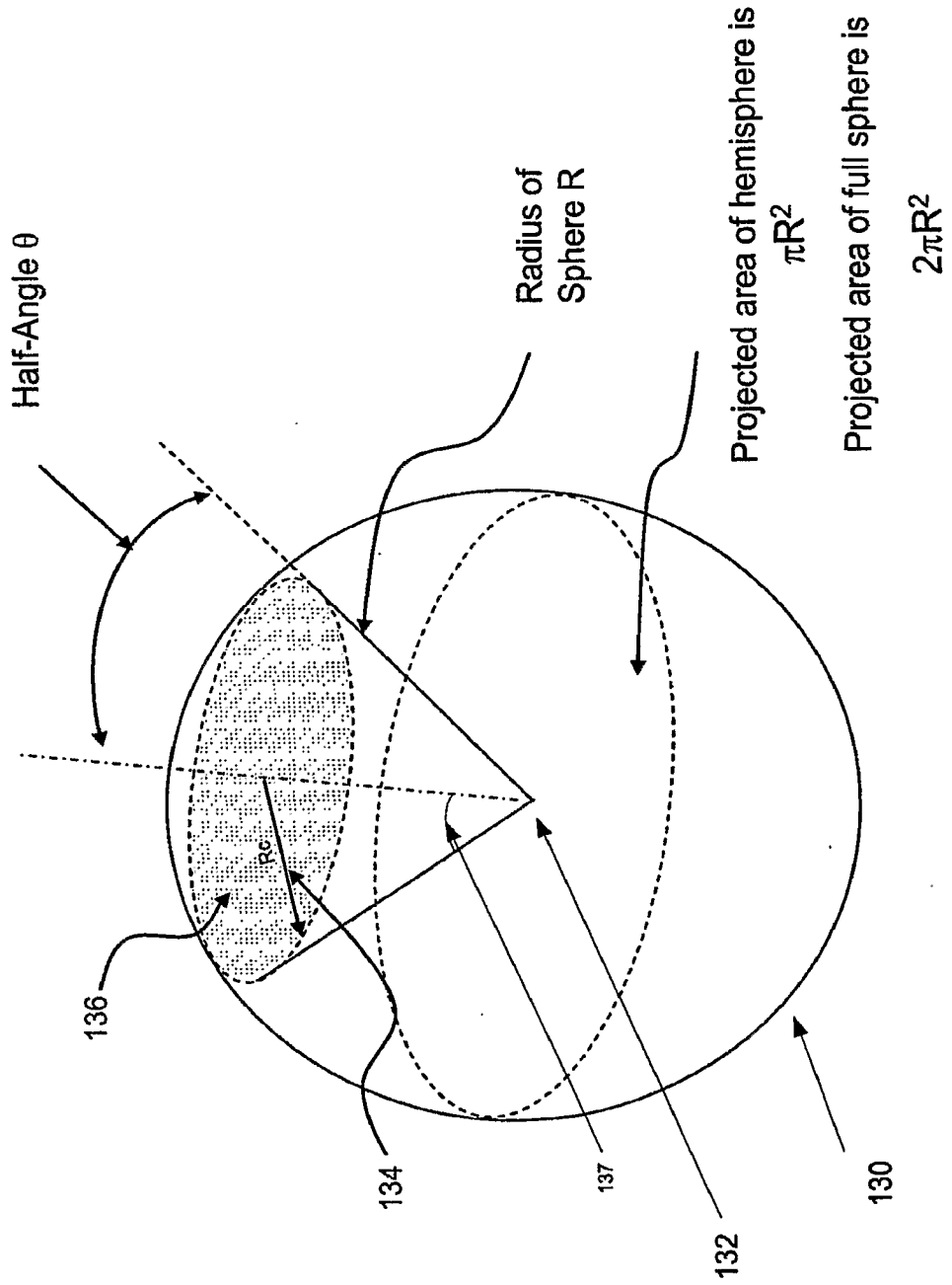

FIGURE 4C

Figure 5



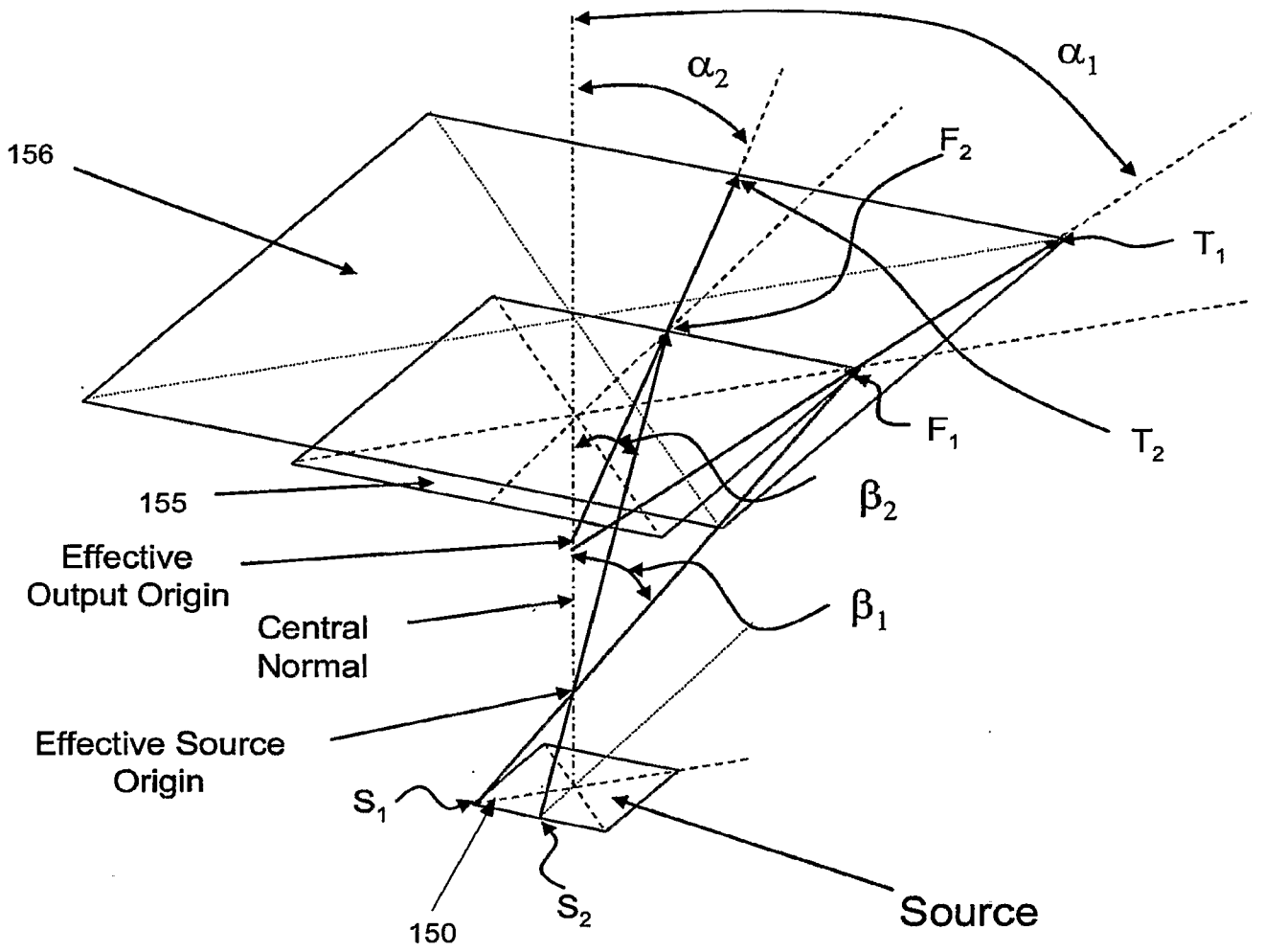

FIGURE 6A

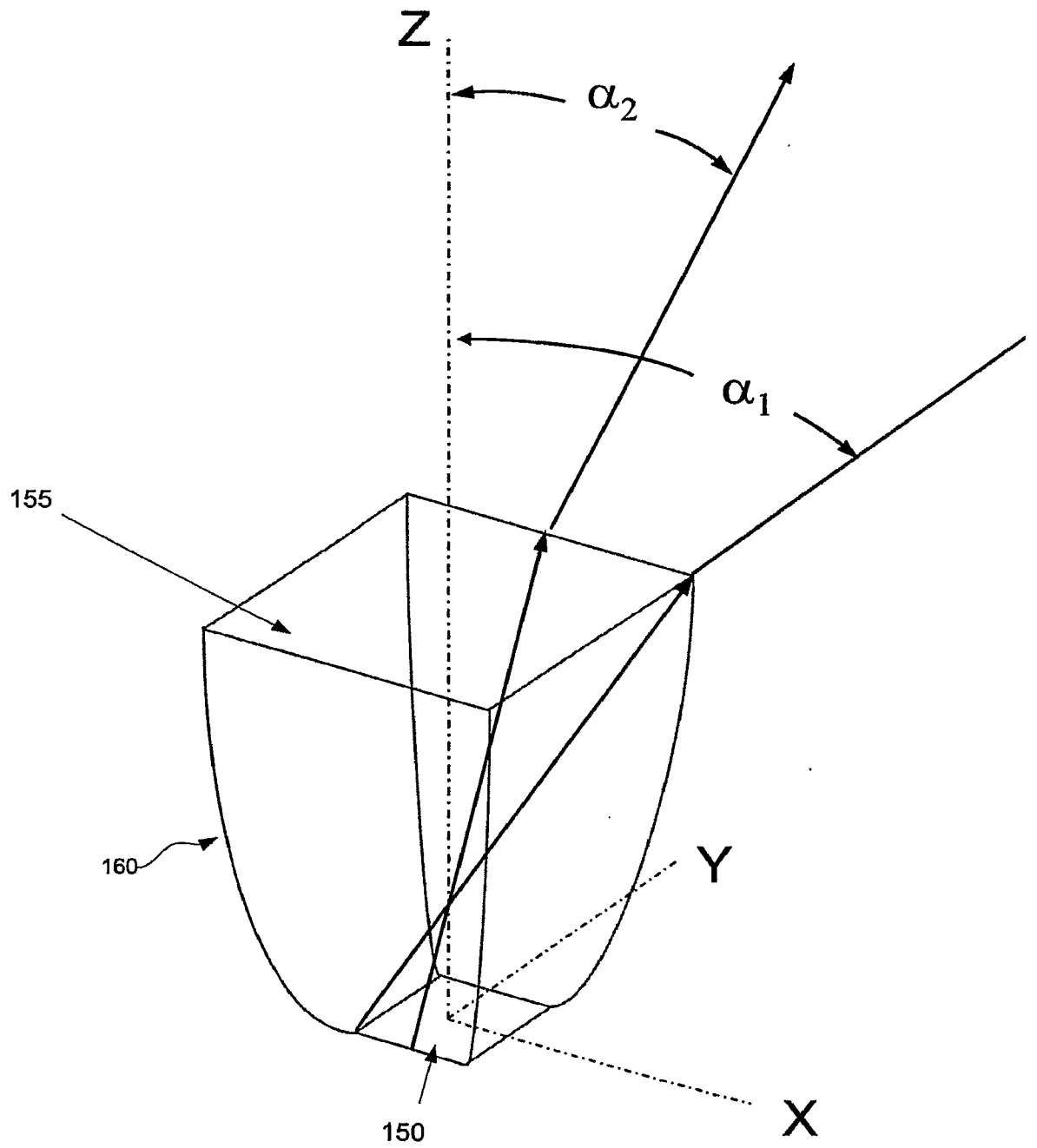

FIGURE 6B

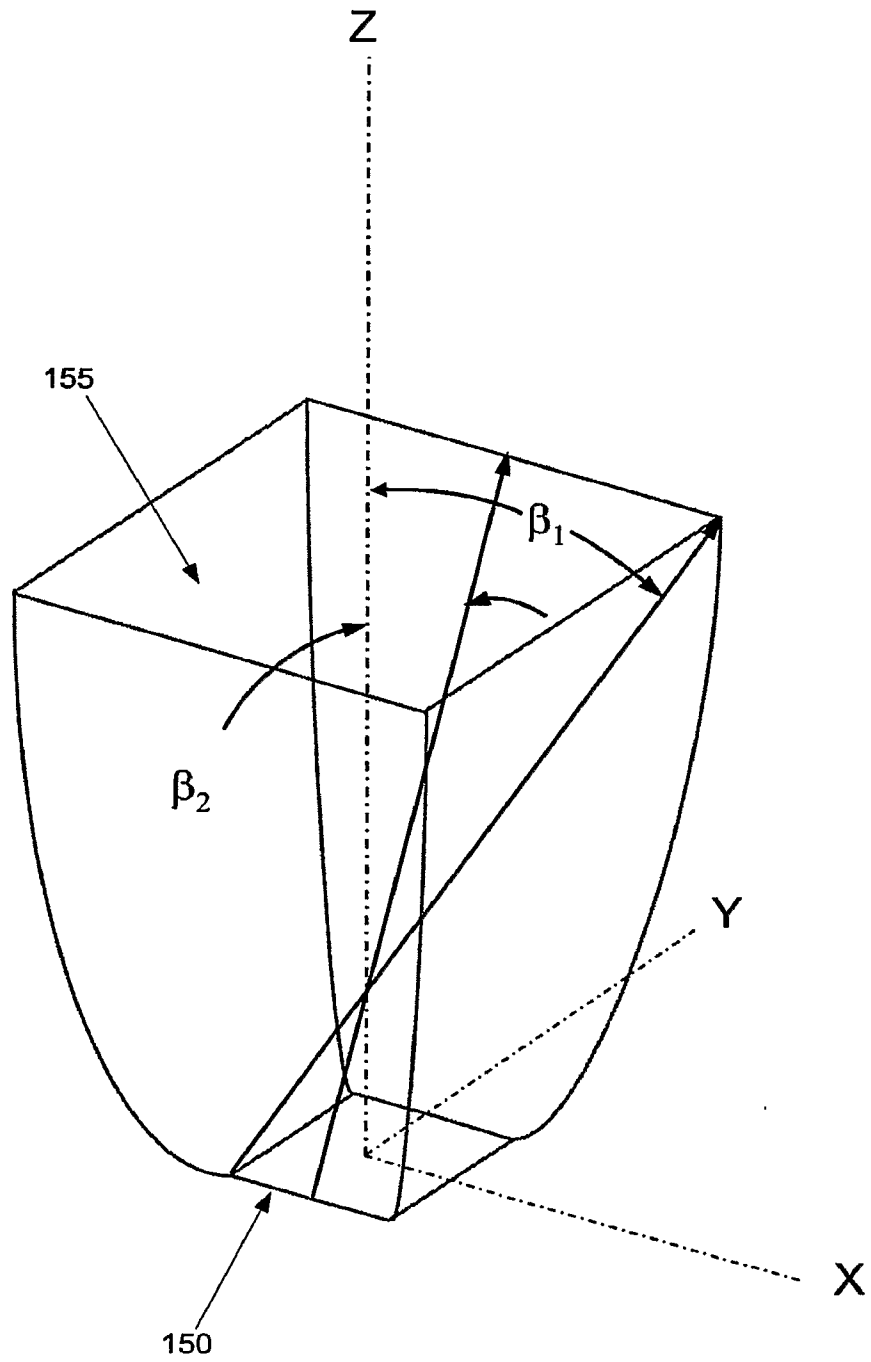
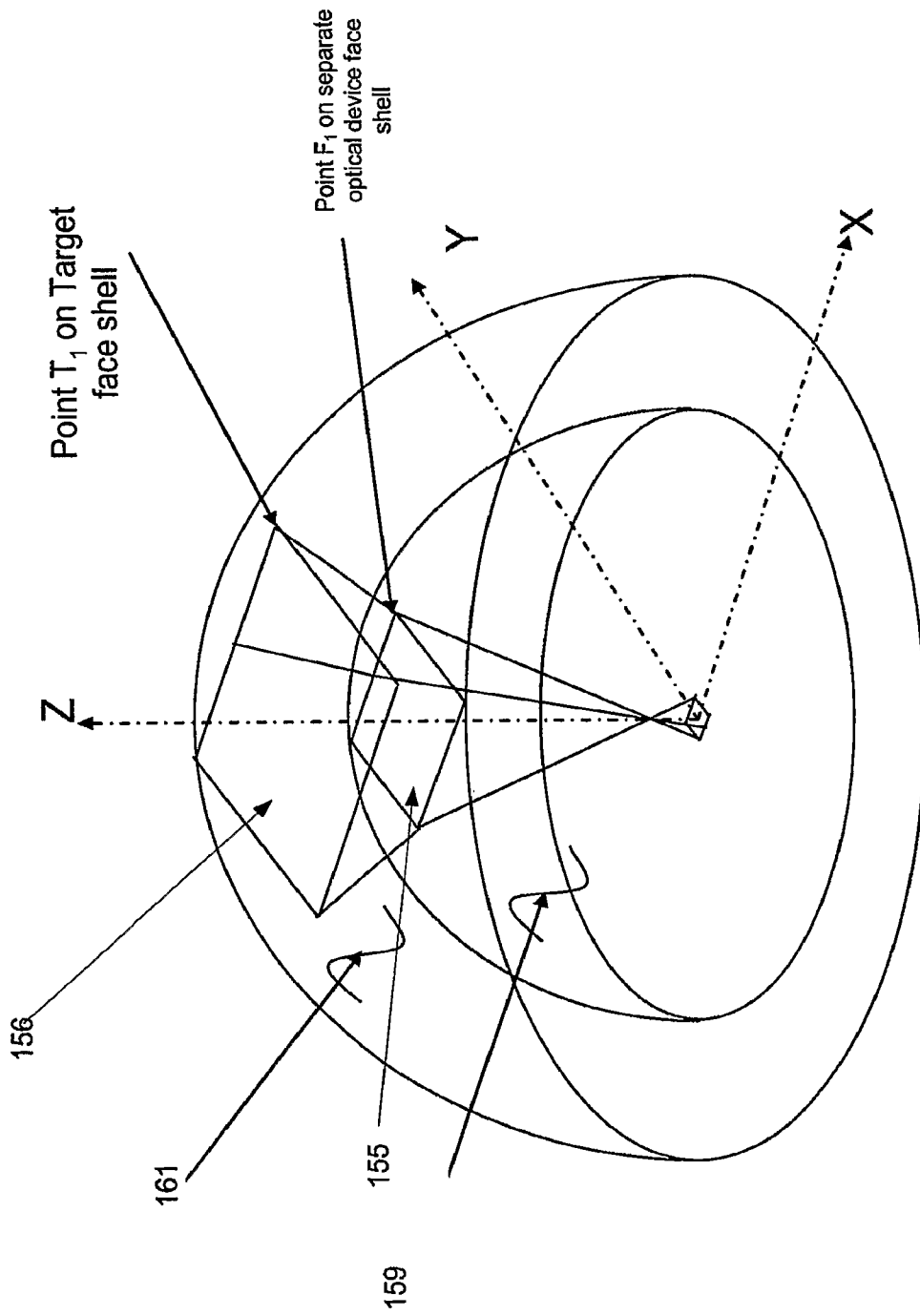

FIGURE 6C







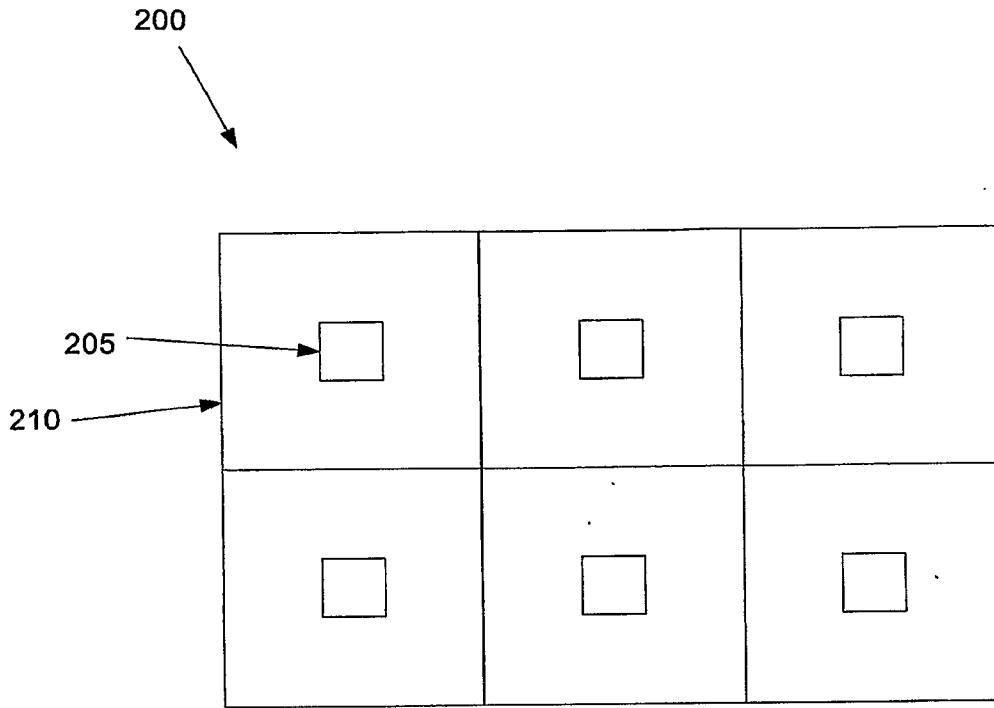

FIGURE 7

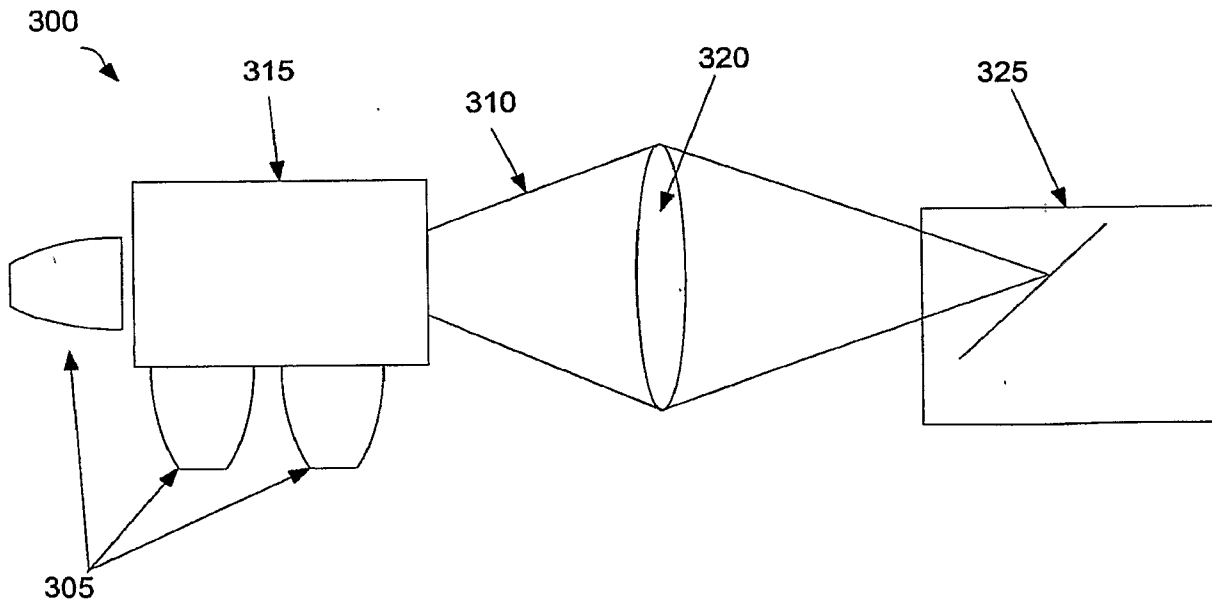

FIGURE 8

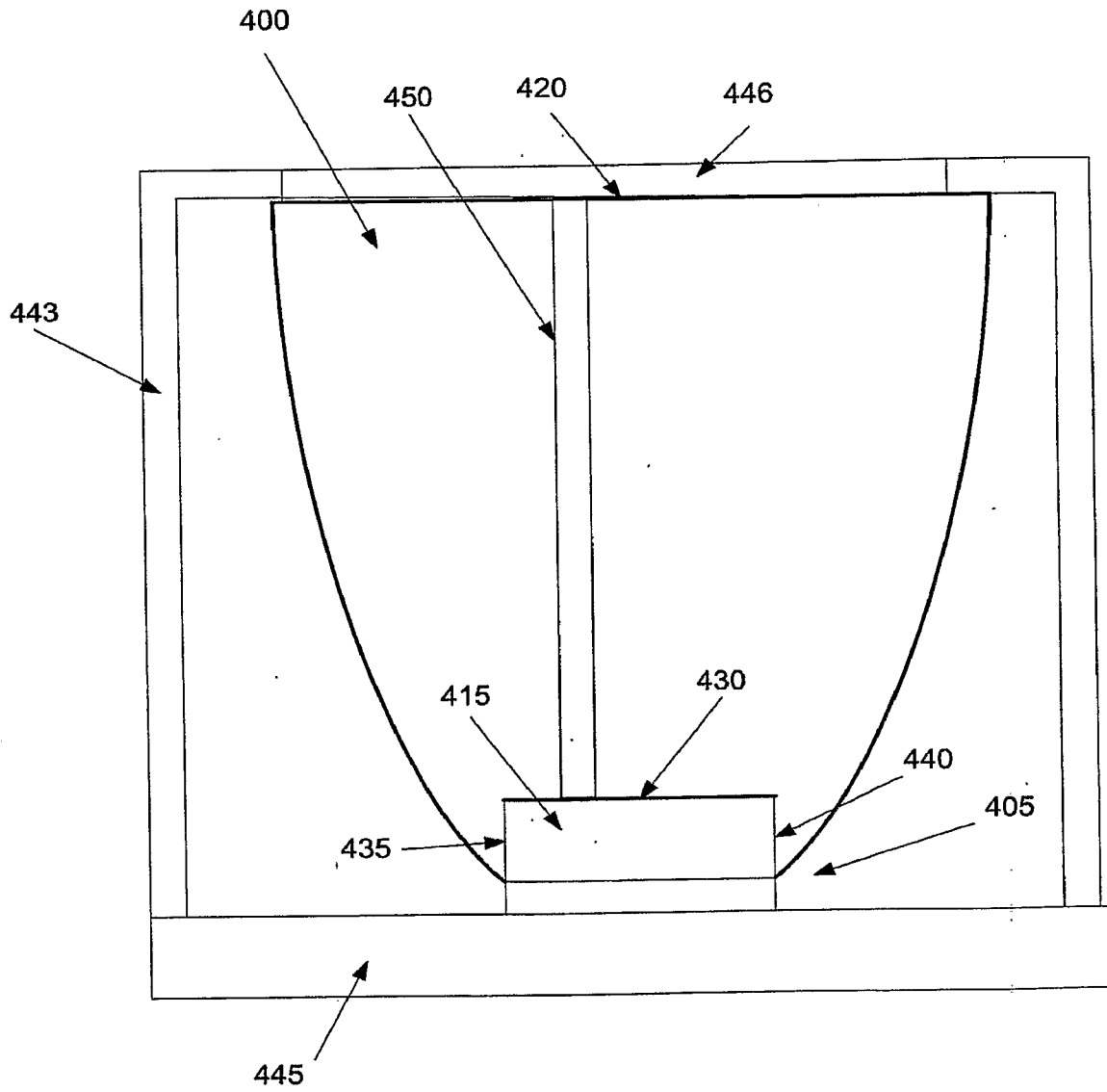

FIGURE 9

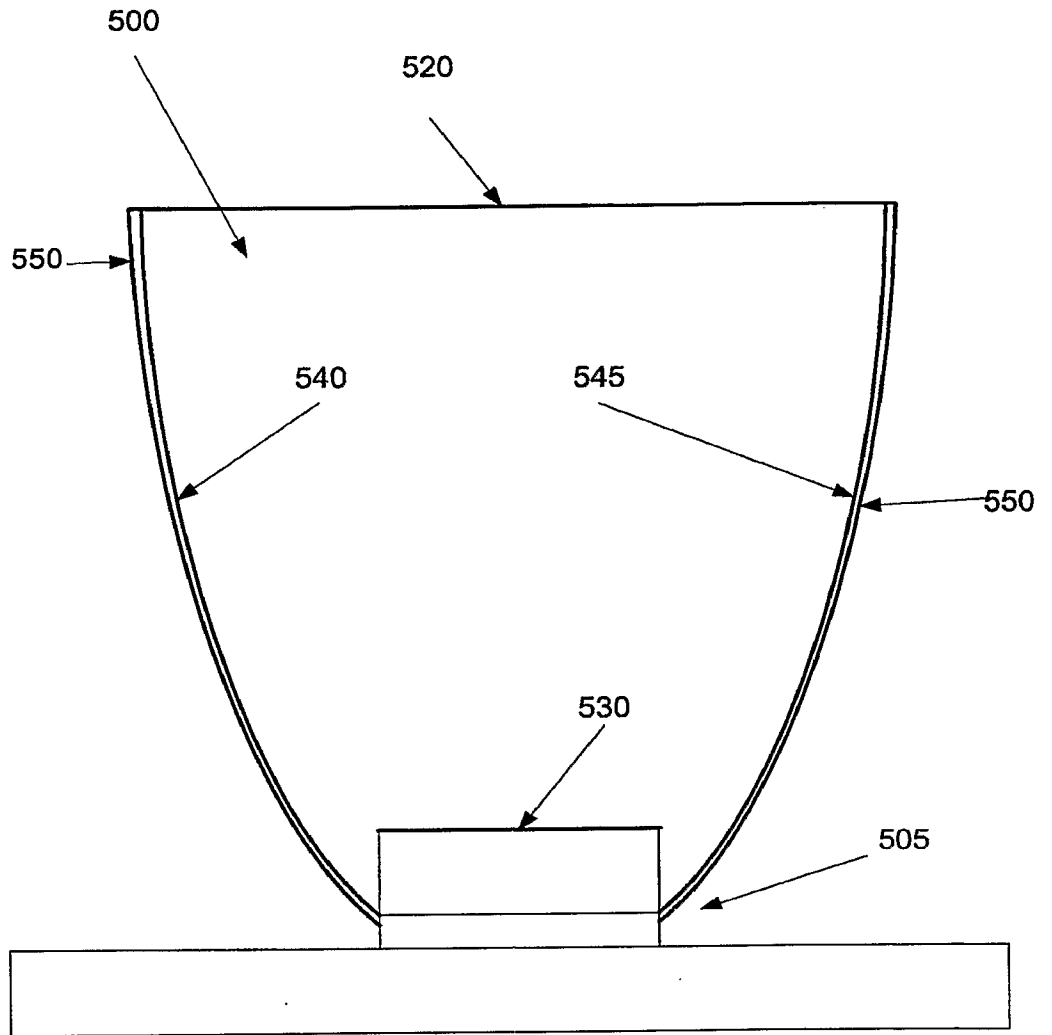

FIGURE 10

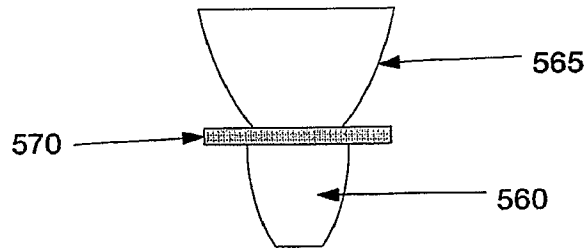

FIGURE 11

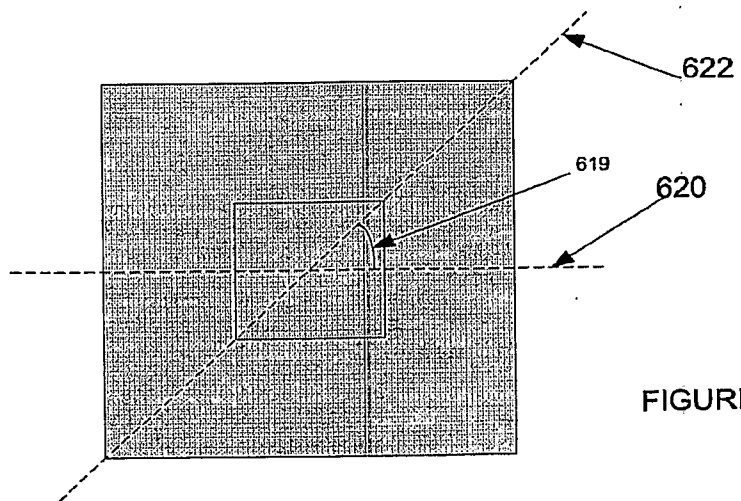
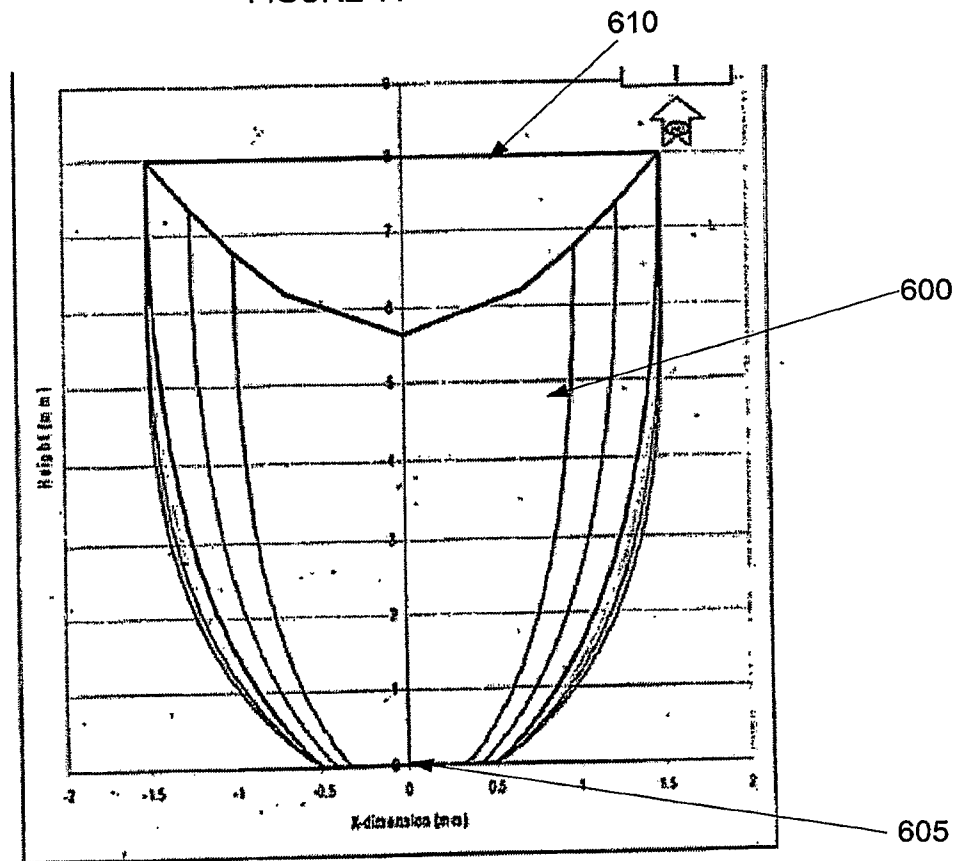

FIGURE 12