

J. KRUTTSCHNITT.
RAIL SPIKE.
APPLICATION FILED DEC. 30, 1911.

1,084,804.

Patented Jan. 20, 1914.

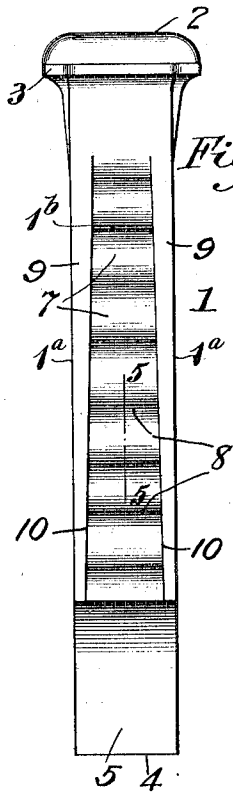

Fig. 1.

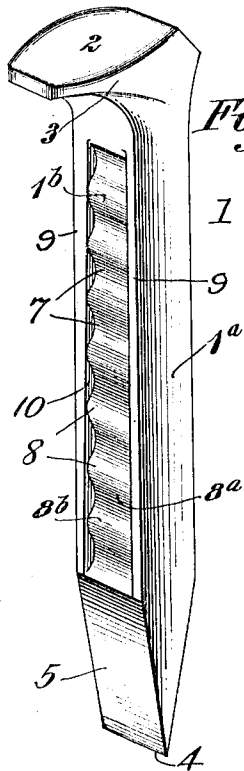

Fig. 2.

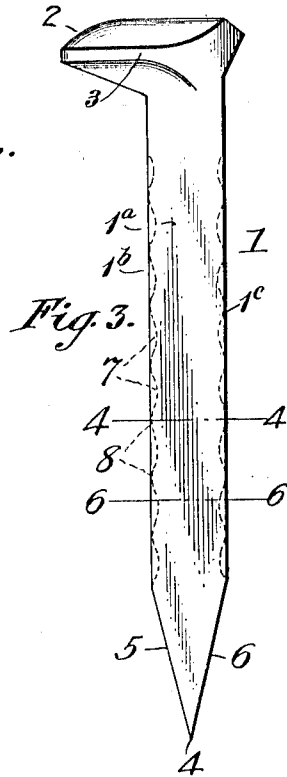

Fig. 3.

Fig. 5.

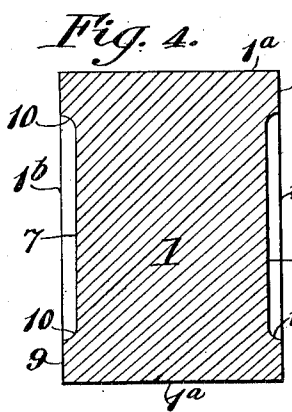

Fig. 4.

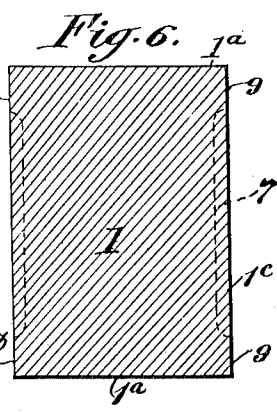
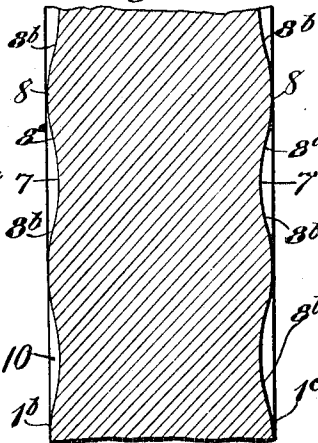

Fig. 6.

Witnesses:
W. W. Delin.
Francis C. Allen.

Inventor:
Julius Kruttschnitt.
By *[Signature]* atty

UNITED STATES PATENT OFFICE.

JULIUS KRUTTSCHNITT, OF NEW YORK, N. Y.

RAIL-SPIKE.

1,084,804.

Specification of Letters Patent.

Patented Jan. 20, 1914.

Continuation in part of applications Serial Nos. 566,004 and 566,006, filed June 9, 1910. This application filed December 30, 1911. Serial No. 668,790.

To all whom it may concern:

Be it known that I, JULIUS KRUTTSCHNITT, a citizen of the United States, and a resident of the city of New York, county of New York, and State of New York, have invented certain new and useful Improvements in Rail-Spikes, of which the following is a specification.

My invention relates to improvements in rail spikes for securing railroad rails to the wooden cross ties in railway track construction and maintenance.

This application is a continuation in part of my applications Serial No. 566,004 and Serial No. 566,006, both filed June 9th, 1910 and abandoned in favor of this application.

The object of my invention is to provide a rail spike which shall be of greater holding power than an ordinary rail spike and yet possess all of its desirable characteristics such as inherent strength, standard dimensions, familiar appearance and low cost, and which may be both driven and withdrawn in the usual manner, which will drive straight as in the case of the ordinary spike and as effectually save the wood around the spike and exclude water, and which unlike the ordinary spike will measurably increase in holding power after it is driven into a wooden tie.

My novel article of manufacture comprises a rail spike having the general or outline configuration of an ordinary or plain rail spike but formed with corrugations of a kind hereinafter described, whereby the holding power of the spike is much increased.

My invention will be more readily understood by reference to the accompanying drawings illustrating the same in preferred form, forming part of this specification, and in which;

Figure 1 is a front face or rail side elevation of my novel rail spike; Fig. 2 is a perspective view thereof; Fig. 3 is a side view of the same; Fig. 4 is an enlarged transverse section on the line 4—4 of Fig. 3; Fig. 5 is a similarly enlarged longitudinal section on the line 5—5 of Fig. 1; and, Fig. 6 is a transverse section on the line 6—6 of Fig. 3.

As clearly shown in the drawings, the spike has the general form, size and outline or configuration of an ordinary rail spike; inasmuch as it has a square shank 1 which,

preferably, is straight, that is neither curved nor tapered, and which terminates in a chisel or cutting point 4, 5, 6, at right angles to the inwardly offset head 2. This head is of usual form with side projections or ears 3 for use in pulling the spike.

1^a and 1^a are the sides of the spike shank, 1^b is the front or rail side face of the shank, and 1^c is the rear face of the spike shank. The front and rear faces are preferably parallel and likewise the sides are preferably parallel. The front and rear faces of the shank are formed with transverse corrugations. These corrugations are of wave form and in each case extend from the head to the chisel point. By wave form I mean that the corrugations are of substantial equal depth and height and are substantially symmetrical in longitudinal section, as indicated in Fig. 3 and Fig. 5. The top curves or outer lines, 8, of the corrugations are preferably flush with respective front and rear faces 1^b, 1^c of the shank and the depressions, 7, are preferably of equal depth throughout. The corrugations are of less width than the shank faces wherein they are formed. By so forming them I provide guide portions 9, 9 which constitute the longitudinal boundaries of the corrugations and make substantial side flanges that add to the strength of the spike and also constitute longitudinal guiding faces or ribs which facilitate the straight driving of the spike. As clearly shown in Fig. 1 the corrugations increase in width from the head of the spike to the chisel point thereof. By thus forming the spike I provide relatively inclined wedging walls 10, 10 which are nearest together at the top and tend to compress the wood fibers laterally as the spike is driven. As shown the corrugations are best symmetrically disposed on opposite faces of the shank. It will be observed that corrugations of this kind provide a plurality of inwardly and downwardly inclined surfaces 8^a which do not materially interfere with the driving of the spike but rather tend to make the driving easier, and it will also be seen that the surfaces 8^b are outwardly and downwardly inclined, for a purpose about to be defined.

When the spike is driven into a cross tie the chisel point cuts the wood fibers transversely and displaces them in front of and at the rear of the spike. As the spike de-

scends into the wood it cuts its way cleanly therein by reason of the square shape of the spike, and finally so tightly closes the resultant hole as to exclude water from the spike hole fully as well as in the case of an ordinary square shanked rail spike.

When the spike has been set in the wood the wood fibers that present their downwardly deflected ends to the front and rear faces of the spike are quick to spring back against the corrugation faces 8^b and from the first coat therewith to make the withdrawal of the spike difficult. And after the spike has been in the wood for a length of time the wood so swells or tends to resume its original state that the depressions of the corrugations are filled with firm wood, chiefly fiber ends downwardly opposed to the oppositely disposed portions 8^b of the corrugations. Thus the spike is held much more firmly than an ordinary spike. At the same time the corrugations are not of a shape to abrade or broom the wood when the spike is forcibly withdrawn and therefore when the spike is replaced in the same hole, as sometimes happens, it will again be firmly engaged with the containing wood.

Having thus described my invention I claim as new and desire to secure by Letters Patent:

1. As a new article of manufacture, a rail spike having a head and a chisel pointed shank, said shank presenting plain sides and a corrugated face, the corrugations being of wave form and of less width than such face and having their tops substantially flush therewith.

2. As a new article of manufacture, a rail spike having a head and a chisel pointed shank, said shank presenting plain sides and corrugated front and rear faces, the corrugations being of wave form and of less width than respective faces and having their tops substantially flush therewith.

3. As a new article of manufacture, a rail spike having a head and a chisel pointed shank, said shank presenting symmetrically corrugated front and rear faces, the corrugations being of wave form and of less width than respective faces and having their tops substantially flush therewith.

4. As a new article of manufacture, a rail

spike having a head and a chisel pointed shank, said shank presenting symmetrically corrugated front and rear faces, the corrugations being of wave form and of less width than respective faces and having their tops substantially flush therewith, and said corrugations gradually increasing in width from the head to the chisel point.

5. As a new article of manufacture, a rail spike having a head and a chisel pointed shank, said shank having plain sides and presenting a transversely corrugated face and longitudinal corrugation-bounding guiding-rib portions, said corrugations being of wave form and having their tops substantially flush with said rib portions.

6. As a new article of manufacture, a rail spike having a head and a chisel pointed shank, said shank having plain sides and presenting a transversely corrugated face and longitudinal corrugation-bounding guiding-rib portions that are closer together at the top than at the bottom, said corrugations being of wave form and having their tops substantially flush with said rib portions.

7. As a new article of manufacture, a rail spike having a head and a chisel pointed shank, said shank presenting a transversely corrugated face and longitudinal corrugation-bounding guiding ribs and the corrugations presenting downwardly and outwardly inclined fiber-end abutting surfaces, substantially as and for the purpose specified.

8. As a new article of manufacture, a rail spike having a head and a chisel pointed shank, said shank presenting front and rear faces each containing transverse corrugations bounded by longitudinal guiding ribs and the corrugations being symmetrically disposed in said faces and presenting downwardly and outwardly inclined fiber-end abutting surfaces.

In testimony whereof, I have hereunto set my hand, this 23 day of December, 1911, in the presence of two subscribing witnesses.

JULIUS KRUTTSCHNITT.

Witnesses:

HUGH NEILL,
F. E. TILLEY.