

Jan. 23, 1951

W. A. BARNES

2,539,294

TOOL

Filed May 21, 1945

2 Sheets-Sheet 1

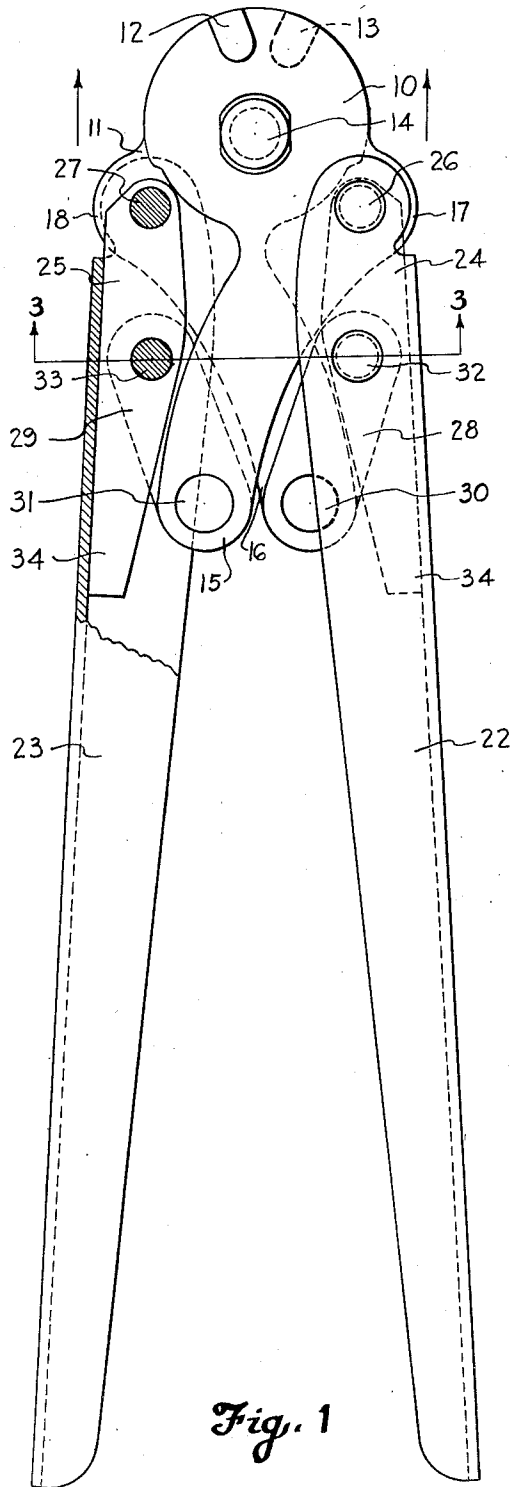

Fig. 1

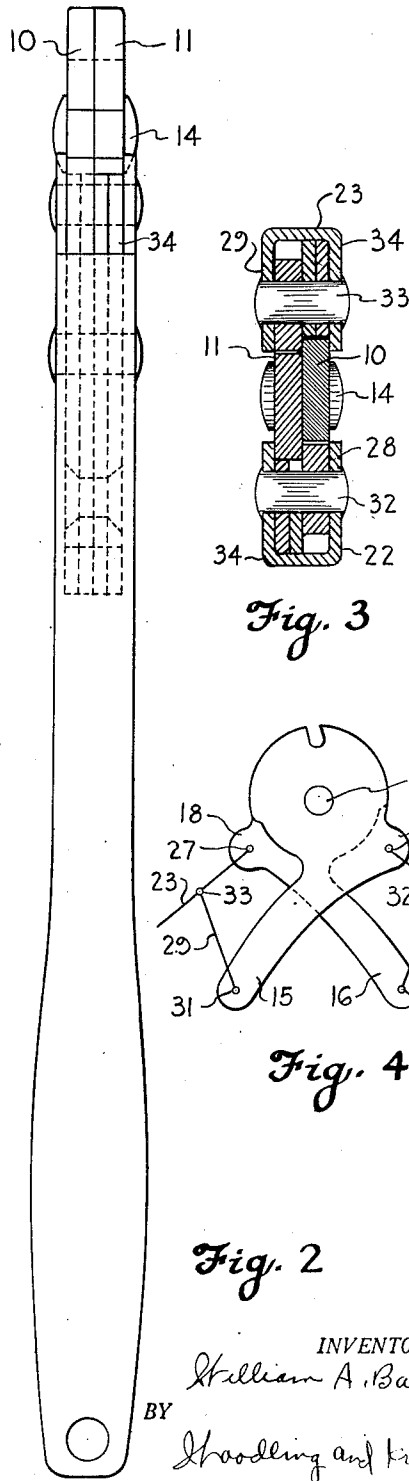

Fig. 2

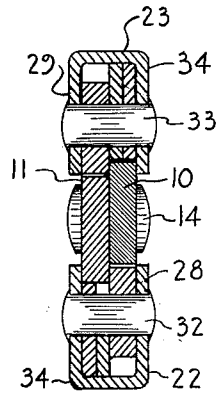

Fig. 3

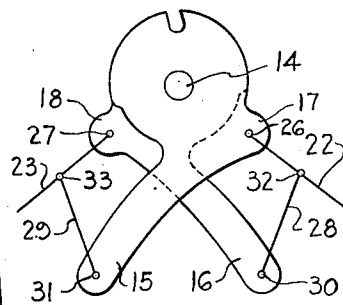

Fig. 4

INVENTOR.

William A. Barnes

BY

Shoodling and Krosch
attys

Jan. 23, 1951

W. A. BARNES

2,539,294

TOOL

Filed May 21, 1945

2 Sheets-Sheet 2

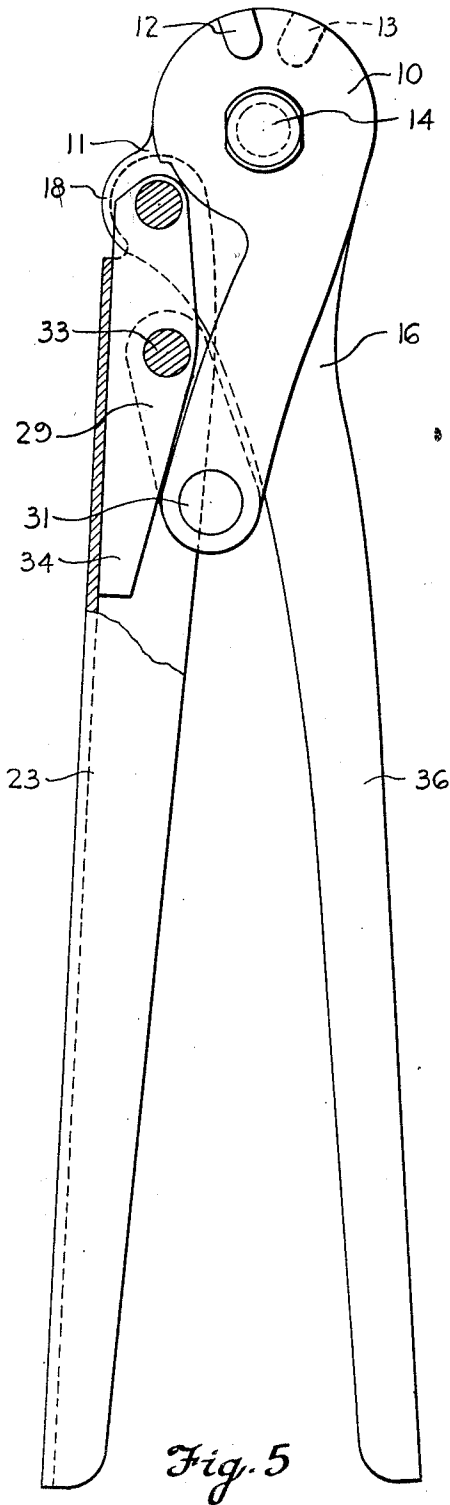

Fig. 5

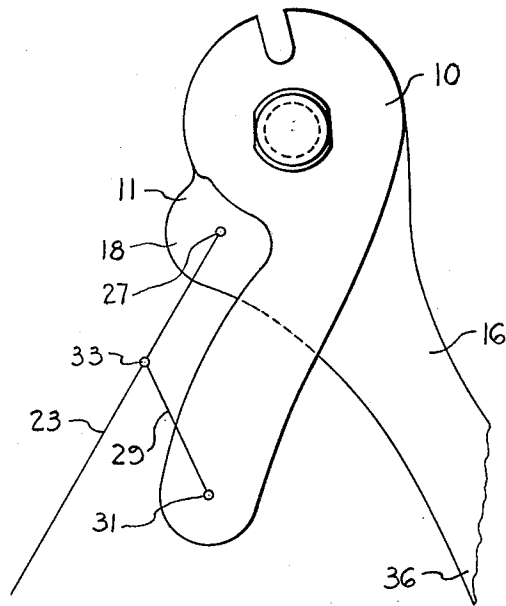

Fig. 6

INVENTOR.

BY *William A. Barnes*
Shoodling and Krost
attys

UNITED STATES PATENT OFFICE

2,539,294

TOOL

William A. Barnes, Utica, N. Y., assignor to Utica Drop Forge & Tool Corporation, a corporation of New York

Application May 21, 1945, Serial No. 595,009

3 Claims. (Cl. 30—252)

1

My invention relates in general to hand operated tools and more particularly to hand operated tools having a mechanism for producing a relatively large working force for a relatively small amount of pressure applied to the handles of the tools.

An object of my invention is the provision in a hand operated tool of a mechanism for producing a relatively large working force for a relatively small amount of pressure applied to the handles of the tool.

Another object of my invention is the provision in a hand operated tool of a lever mechanism which produces a large mechanical advantage for applying a relatively large working force to the jaws of the tool.

Another object of my invention is the provision of mounting the lever mechanism substantially within the handles of the tool whereby externally projecting parts are eliminated.

Another object of my invention is the provision of employing the shanks of one of the jaws of the tool as a reaction element against which the lever mechanism operates for applying a working force to the other jaw of the tool.

Other objects and a fuller understanding of my invention may be had by referring to the following description and claims, taken in conjunction with the accompanying drawing, in which:

Figure 1 is a side elevational view of a hand tool embodying the features of my invention;

Figure 2 is an end view of the tool shown in Figure 1;

Figure 3 is a cross-sectional view taken along the line 3—3 of Figure 1;

Figure 4 is a diagrammatic view illustrating my hand tool with the handles shown in the open position;

Figure 5 is a modified form of a tool having the lever mechanism applied to but one side of the tool; and

Figure 6 is a diagrammatic view of Figure 5 showing the handles in their open position.

With particular reference to Figure 1 of the drawing, my hand operated tool comprises two jaws 10 and 11 adapted to be operated by handles 22 and 23. The jaws, as illustrated, are provided respectively with recesses 12 and 13 having cutting edges adapted to cut cable or any other element of like nature. It is to be clearly understood that the jaws of my hand operated tool may be of any particular type and are not limited to the type shown which may be used for cutting a cable or other like element. The jaws 10 and

2

11 have shanks 15 and 16 respectively, and are pivotally connected together in a cross-pivotal relationship by means of a main pivotal connection 14. The shanks and the jaws are of one integral piece whereby when the shanks are operated the jaws are likewise operated. The jaw 10 and its respective integrally connected shank is substantially similar to the jaw 11 and its integrally connected shank. As illustrated, the jaw 10 and its respective shank is provided with a side portion 17 and the jaw 11 with its respective shank is provided with a side portion 18. The handle 22 has its pivotally mounted end 24 pivotally connected to the side portion 17 of the jaw 10 by means of pivot means 26. Similarly, the handle 23 has its pivotally mounted end 25 pivotally connected to the side portion 18 of the jaw 11 by means of pivot means 27. Accordingly, the two handles 22 and 23 are connected respectively to the jaws 10 and 11. The lower end of the shank 15 is connected to the handle 23 by means of a link 29. The lower end of the link 29 is connected to the lower end of the shank 16 by means of a pivot 31 and the upper end of the link 29 is connected to the handle 23 by means of a pivot 33. Similarly, the lower end of the shank 16 is connected to the handle 22 by means of a link 28. The lower end of the link 28 is connected to the lower end of the shank 15 by means of a pivot 30 and the upper end of the link 28 is connected to the handle 22 by means of a pivot 32. The pivot pins 26 and 32 are reinforced by reinforcement links 34 mounted within the handle 22. Similarly, the pivot means 27 and 33 are reinforced by reinforcement links 34 mounted within the handle 23.

When the handle 22, for example, is moved inwardly the pivot means 32 moves towards a straight line drawn between the pivot means 26 and 30. Therefore, a large force is exerted at the pivot means 26 in the direction of the illustrated arrow. A force in the direction of the illustrated arrow rotates the cutting jaw in a counter-clockwise direction about the main pivotal connection 14. Similarly, when the handle 23 is moved inwardly the pivot means 23 approaches a straight line drawn between the pivot means 27 and 31. A large force is therefore exerted upon the pivot means 27 for rotating the cutting jaw 11 in a clockwise direction about the main pivotal connection 14. The closer the pivot means 32 and 33, respectively, approach a straight line drawn between the pivot means 26 and 30, and the pivot means 27 and 31, the greater the mechanical advantage of the linkage mechanism.

3

Accordingly, the lever mechanism produces a relatively large working force on the jaws for a relatively small amount of pressure applied to the handles. The shanks of the jaws are employed as reaction elements against which the lever mechanisms respectively exert forces for rotating the jaws. The Figure 4 illustrates diagrammatically the position of the linkage mechanism when the handles are spread apart. The distance between the pivot means 32 and the pivot means 26 is less than the distance between the pivot means 30 and 26. Similarly, the distance between the pivot means 33 and 27 is less than the distance between the pivot means 31 and 27.

In Figures 5 and 6 I show a modified form of my tool in that the lever mechanism is applied to but one side of the tool. In this embodiment of the invention a handle 36 is connected integrally with the shank 16 and the jaw 11. As the handles 23 and 36 are moved relative to each other, the lever mechanism produces a mechanical advantage for moving the jaws relative to each other whereby a strong working force may be applied to the jaws for a relatively small pressure applied to the handles 23 and 36. The Figure 6 shows diagrammatically the position of the linkage mechanism when the handles are spread to their open position.

In my invention, it is to be noted that the shank which is attached to one of the jaws is employed as a reaction element against which the lever mechanism exerts a force for rotating the other jaw. It is furthermore observed that the linkage mechanism is disposed within the handles which are channel shaped with the result that there are no externally projecting parts which interfere with the ease of handling the tool.

Although I have described my invention with a certain degree of particularity, it is understood that the present disclosure has been made only by way of example and that numerous changes in the details of construction and the combination and arrangement of parts may be resorted to without departing from the spirit and the scope of the invention as hereinafter claimed.

What is claimed is:

1. A tool comprising first and second working jaws having first and second shanks integrally connected respectively thereto, main pivotal connection means for pivotally connecting said jaws with said shanks in cross-pivotal relation with respect to each other, a first handle adapted to pivot said first shank and jaw about said main pivotal connection means, said first jaw having a side portion provided with a pivot opening, a second handle comprising a channel member and having a pivotally mounted end, said channel member having side walls adapted to straddle said side portion of the first jaw, actuating pivotal connection means mounted in said side walls and extending through said first pivot opening for connecting the pivotally mounted end of the second handle to the side portion of the said first jaw at a pivot point spaced from said main pivotal connection means, link means having a first end provided with a first pivot hole and disposed within the channel member of said second handle, said link means having a second end adapted to be pivotally connected to the end of the second shank, first pivot means mounted in said side walls and extending through said first pivot hole for connecting the first end of said link means to said second handle, and second pivot means for

4

connecting the second end of said link means to the end of the second shank, a line extending from the actuating pivotal connection means to the first pivot means and a line from the first pivot means to the second pivot means defining an included obtuse angle at all positions of said second handle means.

2. A tool comprising first and second working jaws having first and second shanks integrally connected respectively thereto, main pivotal connection means for pivotally connecting said jaws with said shanks in cross-pivotal relation with respect to each other, a first handle adapted to pivot said first shank and jaw about said main pivotal connection means, said first jaw having a side portion provided with a pivot opening, a second handle comprising a channel member and having a pivotally mounted end, said channel member having side walls adapted to straddle said side portion of the first jaw, actuating pivotal connection means mounted in said side walls and extending through said first pivot opening for connecting the pivotally mounted end of the second handle to the side portion of the said first jaw at a pivot point spaced from said main pivotal connection means, link means having a first end provided with a first pivot hole and disposed within the channel member of said second handle, said link means having a second end adapted to be pivotally connected to the end of the second shank, first pivot means mounted in said side walls and extending through said first pivot hole for connecting the first end of said link means to said second handle, second pivot means for connecting the second end of said link means to the end of the second shank, a line extending from the actuating pivotal connection means to the first pivot means and a line from the first pivot means to the second pivot means defining an included obtuse angle at all positions of said second handle means, and a reinforcing member in said channel for mechanically interconnecting the actuating pivotal connection means and the first pivot means.

3. A tool comprising a pair of working jaws having first and second shanks respectively, main pivotal connection means for pivotally connecting said jaws with said shanks in cross-pivotal relation with respect to each other, said first jaw having a side portion provided with a first pivot opening, said second jaw having a side portion provided with a second pivot opening, a first handle comprising a channel member and having a pivotally mounted end, a second handle comprising a channel member having a pivotally mounted end, said channel members each having side walls adapted to respectively straddle the said side portions of the first and second jaw members, respectively, first actuating pivotal connection means mounted in said side walls of said first handle and extending through said first pivot opening for connecting the pivotally mounted end of the first handle to the side portion of the first jaw at a pivot point spaced from said main pivotal connection means, second actuating pivotal connection means mounted in the side walls of the second handle and extending through the second pivot opening for connecting the pivotally mounted end of the second handle to the side portion of the second jaw, first link means having a first end provided with a first pivot hole and disposed within the channel member of the first handle, said first link means having a second end adapted to be pivotally connected to the end of the second shank, first pivot means mounted

5

in the side walls of the first handle and extending through said first pivot hole for connecting the first end of the first link means to said first handle, second pivot means for connecting the second end of the first link means to the end of the second shank, a line extending from the first actuating pivotal connection means to the first pivot means and a line from the first pivot means to the second pivot means defining an included obtuse angle at all positions of said first handle means, second link means having a first end provided with a third pivot hole and disposed within the channel member of the second handle, said second link means having a second end adapted to be pivotally connected to the end of the first shank, third pivot means mounted in the side walls of the second handle and extending through the third pivot hole for connecting the first end of the second link means to said handle, and

6

fourth pivot means for connecting the second end of the second link means to the end of the first shank, a line extending from the second actuating pivotal connection means to the third pivot means and a line from the third pivot means to the fourth pivot means defining an included obtuse angle at all positions of said second handle means.

WILLIAM A. BARNES.

REFERENCES CITED

The following references are of record in the file of this patent:

UNITED STATES PATENTS

Number	Name	Date
635,417	Bernard -----	Oct. 24, 1899
955,287	Schofield -----	Apr. 19, 1910
1,299,100	Anderson -----	Apr. 1, 1919

Certificate of Correction

Patent No. 2,539,294

January 23, 1951

WILLIAM A. BARNES

It is hereby certified that error appears in the printed specification of the above numbered patent requiring correction as follows:

Column 5, line 19, after the word "said" insert *second*;
and that the said Letters Patent should be read as corrected above, so that the same may conform to the record of the case in the Patent Office.
Signed and sealed this 27th day of March, A. D. 1951.

[SEAL]

THOMAS F. MURPHY,
Assistant Commissioner of Patents.