



INTERNATIONAL APPLICATION PUBLISHED UNDER THE PATENT COOPERATION TREATY (PCT)

<p>(51) International Patent Classification ⁶ : B65D 83/54</p>	<p>A1</p>	<p>(11) International Publication Number: WO 99/36334 (43) International Publication Date: 22 July 1999 (22.07.99)</p>
<p>(21) International Application Number: PCT/US99/01004 (22) International Filing Date: 19 January 1999 (19.01.99) (30) Priority Data: 9801185.1 20 January 1998 (20.01.98) GB (71) Applicant: MINNESOTA MINING AND MANUFACTURING COMPANY [US/US]; 3M Center, P.O. Box 33427, Saint Paul, MN 55133-3427 (US). (72) Inventor: HODSON, Peter, D.; P.O. Box 33427, Saint Paul, MN 55133-3427 (US). (74) Agents: HOHENSHELL, Jeffrey, J. et al.; Minnesota Mining and Manufacturing Company, Office of Intellectual Property Counsel, P.O. Box 33427, Saint Paul, MN 55133-3427 (US).</p>	<p>(81) Designated States: AL, AM, AT, AU, AZ, BA, BB, BG, BR, BY, CA, CH, CN, CU, CZ, DE, DK, EE, ES, FI, GB, GD, GE, GH, GM, HR, HU, ID, IL, IN, IS, JP, KE, KG, KP, KR, KZ, LC, LK, LR, LS, LT, LU, LV, MD, MG, MK, MN, MW, MX, NO, NZ, PL, PT, RO, RU, SD, SE, SG, SI, SK, SL, TJ, TM, TR, TT, UA, UG, UZ, VN, YU, ZW, ARIPO patent (GH, GM, KE, LS, MW, SD, SZ, UG, ZW), Eurasian patent (AM, AZ, BY, KG, KZ, MD, RU, TJ, TM), European patent (AT, BE, CH, CY, DE, DK, ES, FI, FR, GB, GR, IE, IT, LU, MC, NL, PT, SE), OAPI patent (BF, BJ, CF, CG, CI, CM, GA, GN, GW, ML, MR, NE, SN, TD, TG).</p> <p>Published <i>With international search report. Before the expiration of the time limit for amending the claims and to be republished in the event of the receipt of amendments.</i></p>	

(54) Title: AEROSOL DISPENSER

(57) Abstract

An apparatus is described for use with a pressurised aerosol container (15) having a cylindrical wall (1A) with a central axis. The wall defines a major storage portion of the aerosol container and an opening. The apparatus comprises a ferrule (2A) for closure of the opening, a metered dose valve (62) for dispensing a metered dose of an aerosol formulation from the container. The valve has an inlet (4A). The valve is preferably disposed in the ferrule substantially along the central axis. The apparatus also has an annular member (90A) with an inner end that affords fluid communication between the major storage portion of the aerosol container and the inlet of the valve. The annular member is sized, shaped and positioned to restrict the fluid communication between the major storage portion of the container and the valve inlet to only that fluid communication provided through the opening (82A) of the annular member. The opening is situated so that it is adjacent to the central axis.

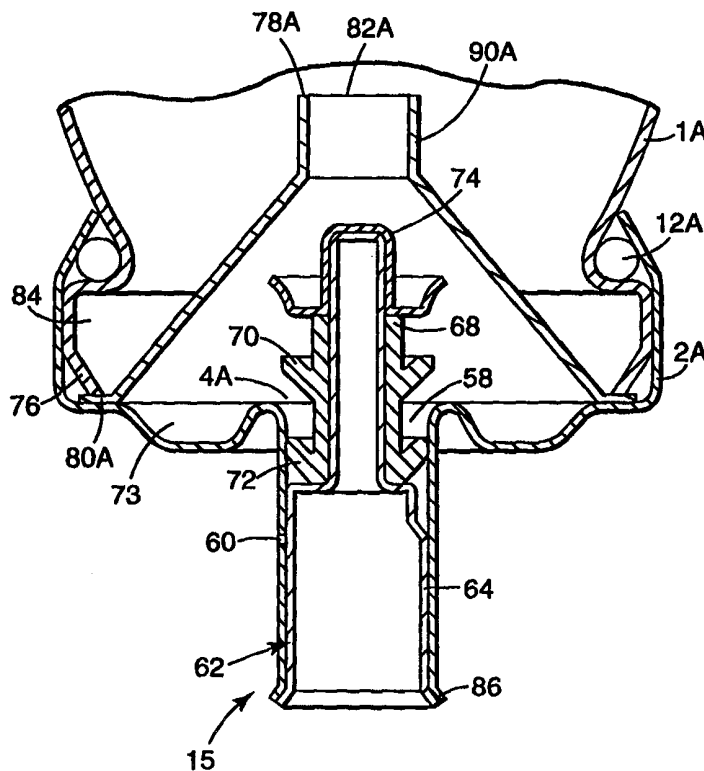

The opening (82A) of the annular member is situated so that it is adjacent to the central axis.

FOR THE PURPOSES OF INFORMATION ONLY

Codes used to identify States party to the PCT on the front pages of pamphlets publishing international applications under the PCT.

AL	Albania	ES	Spain	LS	Lesotho	SI	Slovenia
AM	Armenia	FI	Finland	LT	Lithuania	SK	Slovakia
AT	Austria	FR	France	LU	Luxembourg	SN	Senegal
AU	Australia	GA	Gabon	LV	Latvia	SZ	Swaziland
AZ	Azerbaijan	GB	United Kingdom	MC	Monaco	TD	Chad
BA	Bosnia and Herzegovina	GE	Georgia	MD	Republic of Moldova	TG	Togo
BB	Barbados	GH	Ghana	MG	Madagascar	TJ	Tajikistan
BE	Belgium	GN	Guinea	MK	The former Yugoslav Republic of Macedonia	TM	Turkmenistan
BF	Burkina Faso	GR	Greece			TR	Turkey
BG	Bulgaria	HU	Hungary	ML	Mali	TT	Trinidad and Tobago
BJ	Benin	IE	Ireland	MN	Mongolia	UA	Ukraine
BR	Brazil	IL	Israel	MR	Mauritania	UG	Uganda
BY	Belarus	IS	Iceland	MW	Malawi	US	United States of America
CA	Canada	IT	Italy	MX	Mexico	UZ	Uzbekistan
CF	Central African Republic	JP	Japan	NE	Niger	VN	Viet Nam
CG	Congo	KE	Kenya	NL	Netherlands	YU	Yugoslavia
CH	Switzerland	KG	Kyrgyzstan	NO	Norway	ZW	Zimbabwe
CI	Côte d'Ivoire	KP	Democratic People's Republic of Korea	NZ	New Zealand		
CM	Cameroon	KR	Republic of Korea	PL	Poland		
CN	China	KZ	Kazakstan	PT	Portugal		
CU	Cuba	LC	Saint Lucia	RO	Romania		
CZ	Czech Republic	LI	Liechtenstein	RU	Russian Federation		
DE	Germany	LK	Sri Lanka	SD	Sudan		
DK	Denmark	LR	Liberia	SE	Sweden		
EE	Estonia			SG	Singapore		

AEROSOL DISPENSER

FIELD OF THE INVENTION

The present invention relates to dispensing devices and more particularly to
5 improvements to metered dose inhalers which facilitate enhanced operation of metered-
dose dispensing valves.

BACKGROUND

The art is replete with devices for dispensing suspension-based formulations that
10 meter individual doses of medicament for therapeutic applications by use of a metering
valve. Formulations comprising suspensions of fine medicament particles in aerosol
propellant systems are typically provided in a pressurised liquid phase within an aerosol
container. For example, the liquid phase may include a mixture of chlorofluorocarbons
(CFC's) or one or more hydrofluoroalkanes, such as, P134a (1,1,1,2-tetrafluoroethane) and
15 P227 (1,1,1,2,3,3,3-heptafluoropropane). The formulation may also contain ingredients
other than medicament, such as ethanol and excipients such as surfactants; lubricants and
flavouring agents may also be included. However, the valve should sample the
formulation homogeneously and uniformly in order that the correct dose of medicament is
delivered to the patient on each actuation of the valve.

20 Many widely prescribed medicament substances are more dense than the liquid
phase of a pressurised formulation. This is particularly true for liquid phase mixtures
comprising hydrofluoroalkanes, such as P134a, which tend to be less dense than traditional
CFC mixtures. When the medicament substance is more dense than the liquid phase, the
medicament particles will typically settle gradually with time. This can lead to unduly
25 high medicament concentrations within the aerosol container (e.g. at the bottom of the
container) which can result in a variety of problems including valve clogging and dose
variances. The problem is exacerbated as, even if the solid medicament particles and the
liquid phase are perfectly density matched at one temperature, the medicament may
become relatively more dense at a different temperature. Aerosol inhalers which are left to
30 stand for an extended period of time are particularly susceptible to such problems. The
problem tends to worsen as the contents of an inhaler are consumed since it is possible that
a final excess of drug can potentially reach the valve inlet in a nearly empty inhaler.

Typical existing inhaler metering valves include a bottle emptier or tank retaining cup which is an element that covers or partially surrounds the metering valve's dosage chamber inlet. Bottle emptiers move the effective filling point nearer to the bottom of the dispenser when the dispenser is held in the valve down position. The bottle emptier helps
5 reduce the undeliverable volume of formulation remaining in the dispenser at the end of its life.

Bottle emptiers tend to restrict access of medicament formulation to the metering valve inlet which may result in loss of prime for the valve. By loss of prime, it is meant that doses of reduced weight could be provided by the valve, particularly when the aerosol
10 container is stored for a prolonged period of time in a valve-up orientation. The loss of prime occurs when any liquid leaks or is shaken from the valve, as medicament formulation tends to be unable subsequently to completely refill the valve tank, probably due to the constricted inlet geometry, the presence of the bottle emptier or other factors.

PCT WO96/28367 discloses valves which have an unconstricted tank inlet
15 geometry that allows medicament formulation to easily enter the metering volume when the valve is actuated. Formulations which tend to provide an unduly high local concentration of medicament if not properly shaken can pose problems for such a valve.

U.S. Patent No. 4,944,433 discloses a valve for dispensing metered doses from a container comprising an element disposed about the valve housing and extending radially
20 therefrom toward a wall of the container. The element substantially closes the space between the wall of the container and the valve housing, but does provide a space adjacent the wall of the container. The element has a raised peripheral portion adjacent the wall of the container. However, containers which are left on their sides for extended periods of time may tend to accumulate sediments at the very point (the space adjacent the wall of the
25 container) where this device affords access to the valve inlet with the attendant disadvantages associated with affording sediment access to the valve inlet. Additionally, this device may be difficult to construct as performance of the device may be particularly sensitive to manufacturing tolerances.

Slight dimensional deviations may cause serious adverse effects on the
30 performance of the device. It is believed that the cross-sectional area of the space adjacent the wall of the container would be unduly influenced by tolerances and dimensional

deviations which could lead to an undesirably large cross-sectional area.

GB-2178398A, 2198117A and 2298187A disclose metering valves for metered dose inhalers comprising a valve body or housing which envelopes the metering chamber and valve stem. There is an opening, aligned with the central axis of the valve stem, to allow passage of aerosol formulation to the inlet of the metering chamber. In each case the opening in the housing is spaced from the inlet to the metering chamber, which is believed to result in an undeliverable volume of formulation remaining in the dispenser.

SUMMARY OF THE INVENTION

According to the present invention there is provided an apparatus for use with a pressurised aerosol container having a substantially cylindrical wall with a central axis, the wall defining a major storage portion of the aerosol container and an opening, the apparatus comprising:

a ferrule for closure of said opening,

a metered dose valve for dispensing a metered dose of an aerosol formulation from the container, the valve having an inlet, the valve being disposed in the ferrule substantially along the central axis, and

an annular member having an inner end defining an opening that affords fluid communication between the major storage portion of the aerosol container and the inlet of the valve, the annular member being sized, shaped and positioned to restrict the fluid communication between the major storage portion of the container and the valve inlet to only that fluid communication provided through the opening of the annular member, and the opening being situated so that it is substantially adjacent the central axis.

The present invention provides an improvement to metered dose dispensers which effectively and efficiently dispenses medicament by improving the operation of the metering valve by reducing the chances of clogging of the metering valves by formulations, even formulations which could give rise to unduly high medicament concentrations if improperly shaken, and by reducing the access of unduly high medicament concentrations to the valve inlet in an aerosol container, even when it has been left on its side for an extended period of time.

The present invention includes an annular member having an inner end defining an opening that affords fluid communication between the major portion of the aerosol container and the inlet of the valve. The annular member is a separate component from the valve, which facilitates manufacture since it does not add a further component to the valve assembly. The annular member may be sized and shaped such that it may be retained in place when the ferrule is attached to the aerosol container. The annular member is positioned to restrict the fluid communication between the major portion of the container and the valve inlet to only that fluid communication provided through the opening of the annular member. The opening is situated so that it is substantially adjacent the central axis of the cylindrical wall of the container.

The invention has particular utility with medicaments that have particles. The annular member is preferably sized, shaped and positioned to comprise a substantially one-way valve which restricts access of unduly high concentrations of medicament particles from the major portion of the container to the valve inlet but which affords passage of unduly high medicament particle concentrations near the valve inlet away from the valve inlet and toward the major portion of the aerosol container where the unduly high concentrations of medicament particles may be eliminated.

The annular member has a diameter along the central axis. The diameter preferably decreases along the central axis in a direction away from the valve inlet. In one embodiment, the annular member of the present invention has a portion which projects toward the central axis and a portion which projects along the central axis.

The aerosol container has a peripheral portion adjacent the cylindrical wall of the aerosol container. The annular member prevents fluid communication from the peripheral portion of the aerosol container directly to the valve inlet.

The annular member projects from a position at or near the wall of the container toward the central axis and prevents direct communication of unduly high concentrations of medicament in a position near the wall of the container to the valve inlet. The configuration also reduces the volume of undeliverable formulation remaining in the container. Preferably, the opening of the annular member is situated substantially adjacent the valve inlet.

DESCRIPTION OF DRAWING

The present invention will be further described with reference to the accompanying drawings wherein like reference numerals refer to like parts in the several views, and wherein:

5 Figure 1 is a partial cross-sectional view of a first embodiment of improved aerosol dispensing device according to the present invention;

 Figure 2 is a partial cross-sectional view of a second embodiment of improved aerosol dispensing device according to the present invention; and

 Figure 3 is a partial cross-sectional view of a third embodiment of improved aerosol dispensing device according to the present invention.

10

DETAILED DESCRIPTION

Referring now to Figure 1 of the drawing, there is shown a first embodiment of device according to the present invention. The present invention provides an improvement to medicament dispensers, particularly metered dose inhalers which dispense metered amounts of aerosol medicament formulations. The medicaments may be from any suitable therapeutic category such as, but not limited to antibiotics, proteins/peptides, steroids, bronchodilators, anticholinergics, lipoxygenase inhibitors, PAF antagonists, potassium channel activators, mast cell stabilisers, bradykinin analogs, enkephalins or interleukin. As an example not intended to be limiting, the medicament may be leuprolide, albuterol, insulin, pirbuterol, beclomethasone, terbutaline, salmeterol, fluticasone, tiamicinolone, salbutamol, isoproterenol, epinephrine, fenoterol, formoterol, procaterol, pentamidine, calcitonin, ipratropium, oxitropium, budesonide, combinations thereof or any other composition approved for delivery to a patient. This invention has particular utility with suspension based medicaments.

15

20

25

The present invention is suitable for use in metered dose dispensers which utilise formulations comprising suspensions of fine medicament particles in an aerosol propellant systems. Such formulations typically include micronised particles having a mass median diameter of from 1 to 10 μ m.

The formulation may comprise any formulation suitable for delivery of the aerosol medicament. For example, the liquid phase may include a mixture of chlorofluorocarbons (CFC's) or a mixture of P134a (1,1,1,2-tetrafluoroethane) and ethanol. The formulation may also contain ingredients other than medicament, such as excipients. Surfactants, lubricants and flavouring agents may also be included.

The present invention finds particular utility for use with medicament substances that are more dense than the liquid phase of a pressurised formulation. Hydrofluoroalkanes, such as P134a, tend to be less dense than traditional CFC mixtures. When the medicament substance is more dense than the liquid phase, the medicament particles tend to settle gradually with time leading to a variety of adverse consequences.

According to another aspect of the present invention there is provided a metered dose inhaler that effectively and efficiently dispenses medicament by virtue of an improved operation of the metering valve. The chances of clogging of the metering valve by the formulation (even formulations which are readily susceptible to unduly high medicament concentrations) is substantially reduced by the improvement according to the present invention.

Referring now to Figure 1, the invention comprises an apparatus for use as part of a pressurised aerosol container 15 that has a substantially cylindrical body (not shown) comprising a vial wall 1A with a central axis, a ferrule 2A (with substantially the same axis as that of the vial wall), and a metered dose valve 62 for dispensing aerosol formulation from the container 15. The valve 62 has an inlet 4A which allows a metered portion of the medicament formulation to enter a metering chamber. From the metering chamber, a metered amount of the medicament formulation is subsequently delivered to the patient. The internal portion of the aerosol container has a major storage portion (not all of which is shown but comprising the top part of Figure 1) and a minor portion substantially adjacent the valve inlet 4A. The valve 62 is disposed in the ferrule 2A substantially along the central axis of the wall 1A or the ferrule 2A. The valve shown in Figure 1 is substantially the same as the valve shown in Figure 18 of PCT International Publication No. WO96/28367 (the entire contents of which are herein incorporated by reference). The present invention can also be utilised with the other embodiments of valves shown in of PCT International Publication No. WO96/28367.

Figure 1 illustrates a portion of an inhaler comprising a ferrule 2A which is crimped onto the container wall 1A. The stem of the valve 62 includes an outer metal portion 64 and an elastomeric sealing element 68 comprising skirts 70, 72. A stem cap 74 retains the sealing element 68 and prevents the valve stem from being pushed out of the unit by the pressure of the formulation's propellant. The valve is shown in its non-dispensing position in Figure 1.

To meter a dose of medicament formulation, the valve stem is released and moves outward under the influence of the propellant. As the stem moves, the inner skirt 70 enters the bore of the elongated nose 86 of the valve ferrule 2A, forming a seal with the bore, and defines a metered volume of formulation in the region 58 between the skirts 70, 72 and the ferrule nose bore. Further movement of the stem outwards causes the outer skirt 72 to pass a small spray orifice 60 in the nose 86, causing the metered dose of medicament formulation to be released as an aerosol spray suitable for delivery to the patient's lungs.

Unlike the valve shown in Figure 18 of PCT International Publication No. WO96/28367, the present invention includes an annular member 90A having an inner end 78A defining an opening 82A that affords fluid communication between a major storage portion of the aerosol container (the top portion of Figure 1 and above) and the inlet 4A of the valve 62.

The annular member 90A is sized, shaped and positioned to restrict fluid communication between the major storage portion of the aerosol container and the valve inlet 4A to only that fluid communication provided through the opening 82A of the annular member 90A. The annular member 90A is also sized, shaped and positioned to comprise a substantially one-way valve which restricts access of unduly high concentrations of medicament particles from the major storage portion of the aerosol container to the valve inlet 4A but which affords passage of unduly high medicament concentrations near the valve inlet 4A away from the valve inlet 4A and toward the major portion of the aerosol container where the unduly high concentrations of medicament may be eliminated (e.g. by remixing).

The opening 82A is preferably situated so that it is substantially adjacent the central axis of the cylindrical wall 1A. Placement of the opening 82A in this fashion allows the cross sectional area of the opening 82A to be as small as possible and provides a design that is not unduly sensitive to tolerance vagaries or assembly variances. With the opening 82A placed in the position described, it is highly unlikely that unduly high concentrations of medicament particles will be able to travel from the periphery of the wall 1A to the inlet 4A as the indirect or lengthy path that such particles would have to travel is likely to result in their remixure into the formulation with the attendant reduction in concentration resulting from such remixure.

As illustrated in Figure 1, the annular member 90A has a diameter that generally changes as a function of distance along the central axis. Preferably, the diameter decreases along the central axis in a direction away from the valve inlet (note the portion of the annular member 90A closest to the wall 1A). That portion projects toward the central axis. Also preferably, the annular member 90A includes a portion which projects substantially parallel to the central axis.

As seen in Figure 1, the aerosol container has a peripheral portion adjacent the cylindrical wall 1A. The annular member 90A prevents fluid communication from the peripheral portion of the aerosol container directly to the valve inlet 4A. As a result, the present invention reduces access of unduly high medicament concentrations found near the peripheral portion (e.g. that can appear in an aerosol container which has been left on its side for a long period of time) to the valve inlet 4A.

The annular member 90A projects from a position near the wall 1A of the container toward the central axis and prevents direct communication of unduly high concentrations of medicament in a position near the wall of the container (see 84 in Figure 1) to the valve inlet 4A. The annular region 84 collects the unduly high concentrations of medicament or sediment in a manner that restricts its access to the valve inlet 4A. To gain access to the valve inlet 4A, the unduly high medicament concentration must travel upward in Figure 1 from region 84, then downward through the opening 82A and into 4A. After travelling such a labyrinth like path, the unduly high medicament concentration would have had ample opportunity to mix with the rest of the formulation to thereby eliminate the medicament concentration.

The annular member 90A is preferably sized and shaped to ensure that there is adequate volume in the annular collecting region 84 for all of the drug-bearing sediment to collect as it first settles. The opening 82A is sized and shaped to afford access for the formulation to the valve inlet 4A. As an example not intended to be limiting, the opening 82A can be circular with a diameter between about 2 millimeters and about 6 millimeters, and preferably between about 4 millimeters and about 4.5 millimeters. A 4.5 millimetre opening 82A inside a container 1A with a typical diameter of 21 millimeters would allow approximately 4.6 % of the drug to pass through it ($= 100\% \times 4.5^2 / 21^2$). For a typical 200 dose product, this amount of drug is equivalent to less than 10 doses, and much of this relatively small amount of additional drug will settle down in the lowest region (73) of the ferrule 2A, away from the inlet 4A, if the unit is not shaken. Thus, even if the patient forgets to shake the inhaler prior to its use, the present invention reduces the chances of an unduly high concentration of medicament being delivered to a patient.

O-ring 12A forms a gas-tight seal between the aerosol container 1A and the ferrule 2A. A gas tight seal is not required at the juncture between the annular member 90A, the container 1A and the ferrule 2A.

Figure 2 illustrates a second alternative embodiment of a device 14 according to the present invention which has many parts that are essentially the same as the parts of the device shown in Figure 1 and which have been identified by the same reference number to which the suffix "B" has been added.

The metered dose inhaler comprises a metering valve 14, and a ferrule 2B crimped onto the neck of container 1B (e.g. a vial, the rest of which vial is not shown to emphasise other details) for the medicament formulation.

To operate the valve 14, the patient presses stem 21 so that it moves further into the ferrule 2B. As the stem 21 is subsequently released and returns under the influence of spring 23, another volume of medicament formulation enters the valve via the valve inlet region 4B. The valve inlet is adjacent the bottom of the inhaler when in its valve-down position due to the presence of bottle emptier 3. The bottle emptier 3 is used so that nearly all of the medicament formulation can be delivered from the inhaler without large undeliverable volumes remaining below the level of the valve inlet.

O-ring 12B and gasket seal 92 seal the valve ferrule 2B onto the vial 1B, each providing a back-up seal for the other element.

An annular member 90B projects from a position near the wall 1B of the container toward the central axis and prevents direct communication of unduly high concentrations of medicament in a position near the wall of the container to the valve inlet 4B. The annular region 84B collects the unduly high concentrations of medicament or sediment in a manner that restricts its access to the valve inlet 4B. To gain access to the valve inlet 4B, the unduly high medicament concentration must travel upward in Figure 2 from region 84B, then downward through the opening 82B and into valve inlet region 4B. After travelling such a labyrinth like path, the unduly high medicament concentration would have had ample opportunity to mix with the rest of the formulation to thereby eliminate the excessive medicament concentration.

The opening 82B is sized and shaped to afford access for the formulation to the valve inlet 4B. As an example not intended to be limiting, the opening 82B can be circular with a diameter between about 2 millimeters and about 6 millimeters, and preferably between about 4 millimeters and about 4.5 millimeters. The opening should have a sufficient diameter, or otherwise must be appropriately positioned or shaped, to ensure that the shoulder region 3B of the bottle emptier 3 cannot collide with annular member 90B as the bottle emptier moves along the central axis of the inhaler during valve actuation.

Figure 3 illustrates a third alternative embodiment of a device according to the present invention which has many parts that are essentially the same as the parts of the device shown in Figure 1 and which have been identified by the same reference number to which the suffix "C" has been added.

The metered dose inhaler comprises a metering valve 91, and a ferrule 2C crimped onto the neck of vial 1C which contains the medicament formulation. O-ring 12C provides a gas-tight seal between vial 1C and ferrule 2C. The metering valve 91 comprises a body 52 having an annular seal or gasket 56. The body 52 defines a chamber 6 having an inlet passage 4C and an outlet passage 10 for dispensing pressurised aerosol formulation. A valve stem 54 extends through the chamber 6 and is movable between a closed or priming position shown in figure 3 and a dispensing position (not shown). The valve stem

54 is biased to its dispensing position by means of a spring 59. The valve stem 54 is fitted with an inner seal 16 and an outer seal 18 which provide gas-tight seals between the valve stem 54 and the inner wall of the chamber 6. The chamber 6, the external dimensions of the valve stem 54, and the position of the seals 16, 18 are arranged to define a pre-determined volume within the chamber 6 between the seals 16,18.

In operation the valve stem 54 is moved inwardly against the bias of the spring 59 to the priming position shown in Figure 3. In the closed or priming position, aerosol formulation contained in vial 1C may enter or leave the chamber via the annular inlet between the seal 16 and the open end of the chamber. Access to the valve inlet in this design is somewhat free, thereby enhancing the value of the annular member 90C in this design. When the valve stem 54 is released, the valve stem moves to its dispensing position (not shown) under the influence of the spring 59. During this movement, the valve seal 16 enters the chamber 6 thereby trapping a metered volume of aerosol formulation between the seals 16, 18 and the walls of the chamber. Further movement of the valve stem 54 moves the metered volume of formulation along the chamber until the valve seal 18 passes the outlet passage 10 thereby allowing the outlet passage 10 to communicate directly with the metered volume of formulation. The formulation is self-propelling and is sprayed through the outlet passage 10 under the influence of the vaporising aerosol propellant. The outlet passage 10 may incorporate one or more small orifices, as shown, to aid break-up of the spray without the need for a separate actuator orifice.

Annular member 90C projects from a position near the wall 1C of the container toward the central axis and prevents direct communication of unduly high concentrations of medicament in a position near the wall of the container to the valve inlet 4C. The annular region 84C collects the unduly high concentrations of medicament or sediment in a manner that the presence of annular member 90C restricts its direct access to the valve inlet 4C. To gain access to the valve inlet 4C, the unduly high medicament concentration must travel upward in Figure 3 from region 84C, then downward through the opening 82C and into 4C. After travelling such a labyrinth like path, the unduly high medicament concentration would have had ample opportunity to mix with the rest of the formulation to thereby eliminate the excessive medicament concentration.

The opening 82C is sized and shaped to afford access for the formulation to the valve inlet 4C. As an example not intended to be limiting, the opening 82C can be circular with a diameter between about 2 millimeters and about 6 millimeters, and preferably between about 4 millimeters and about 4.5 millimeters.

5 The present invention has now been described with reference to several embodiments thereof. It will be apparent to those skilled in the art that many changes can be made in the embodiment described without departing from the scope of the present invention. Thus the scope of the present invention should not be limited to the structure described in this application, but only by structures described by the language of the claims
10 and the equivalents of those structures.

CLAIMS

1. An apparatus for use with a pressurised aerosol container having a substantially cylindrical wall with a central axis, the wall defining a major storage portion of the aerosol container and an opening, the apparatus comprising:

- 5 a ferrule for closure of said opening,
a metered dose valve for dispensing a metered dose of an aerosol formulation from the container, the valve having an inlet, the valve being disposed in the ferrule substantially along the central axis, and
10 an annular member having an inner end defining an opening that affords fluid communication between the major storage portion of the aerosol container and the inlet of the valve, the annular member being sized, shaped and positioned to restrict the fluid communication between the major storage portion of the container and the valve inlet to only that fluid communication provided through the opening of the annular member, and the opening being situated so that it is substantially adjacent the central axis.

15

2. An apparatus according to Claim 1 wherein the medicament has particles, and the annular member is sized, shaped and positioned to comprise a substantially one-way valve which restricts access of unduly high concentrations of medicament particles from the major storage portion of the container to the valve inlet but which affords passage
20 of unduly high medicament particle concentrations near the valve inlet away from the valve inlet and towards the major storage portion of the aerosol container where the unduly high concentrations of medicament particles may be eliminated.

20

3. An apparatus according to Claim 1 wherein the annular member has a
25 diameter along the central axis, which diameter decreases along the central axis in a direction away from the valve inlet.

25

4. An apparatus according to Claim 3 wherein the annular member has a portion which projects towards the central axis and a portion which projects along the
30 central axis.

30

5. An apparatus according to Claim 1 wherein the opening of the annular member is situated substantially adjacent the valve inlet.
6. An apparatus as claimed in Claim 1 in which the area of the opening defined by the annular member is from 3 to 30mm².
7. An apparatus as claimed in Claim 6 in which the opening defined by the annular member is circular having a diameter of from 2 to 6mm.
8. An apparatus as claimed in Claim 7 in which the opening defined by the annular member is circular having a diameter of from 4 to 4.5mm.
9. An assembly according to Claim 1 wherein the aerosol container has a peripheral portion adjacent the cylindrical wall of the aerosol container, and the annular member prevents fluid communication from the peripheral portion of the aerosol container directly to the valve inlet.
10. An apparatus according to Claim 9 wherein the annular member projects from a position near the wall of the container towards the central axis and prevents direct communication of unduly high concentrations of medicament in a position near the wall of the container to the valve inlet.
11. An assembly as claimed in Claim 1 in which the area of opening defined by the annular recess is less than 20% of the total cross-section area of the container at the plane of said opening.
12. An assembly as claimed in Claim 11 in which the area of opening defined by the annular recess is less than 10% of the total cross-section area of the container at the plane of said opening.

13. An assembly as claimed in Claim 12 in which the area of opening defined by the annular recess is less than 5% of the total cross-section area of the container at the plane of said opening.

5 14. An aerosol product comprising an assembly as claimed in Claim 1 containing an aerosol formulation comprising medicament particles suspended in an aerosol propellant system.

10 15. An aerosol product comprising an assembly as claimed in Claim 14 in which the aerosol propellant system comprises P134a.

16. An aerosol product comprising an assembly as claimed in Claim 15 in which the aerosol formulation additionally comprises ethanol.

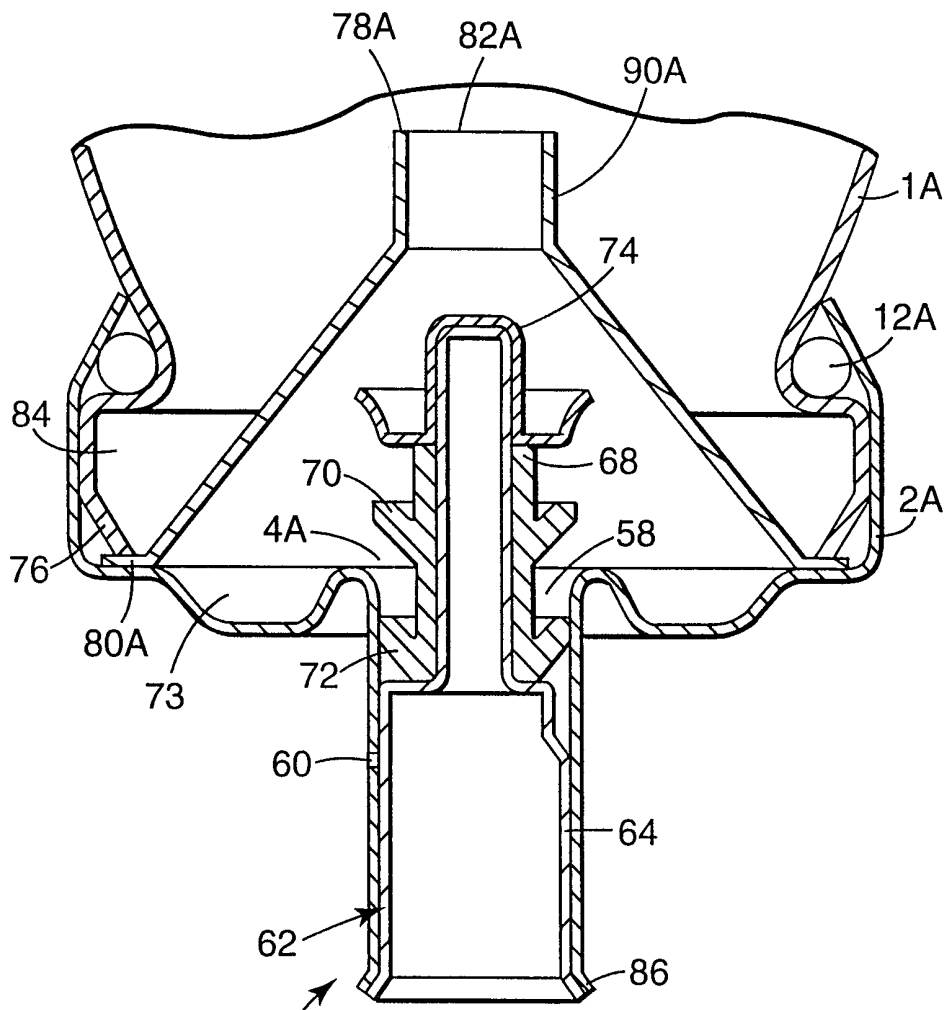

15 **Fig. 1**

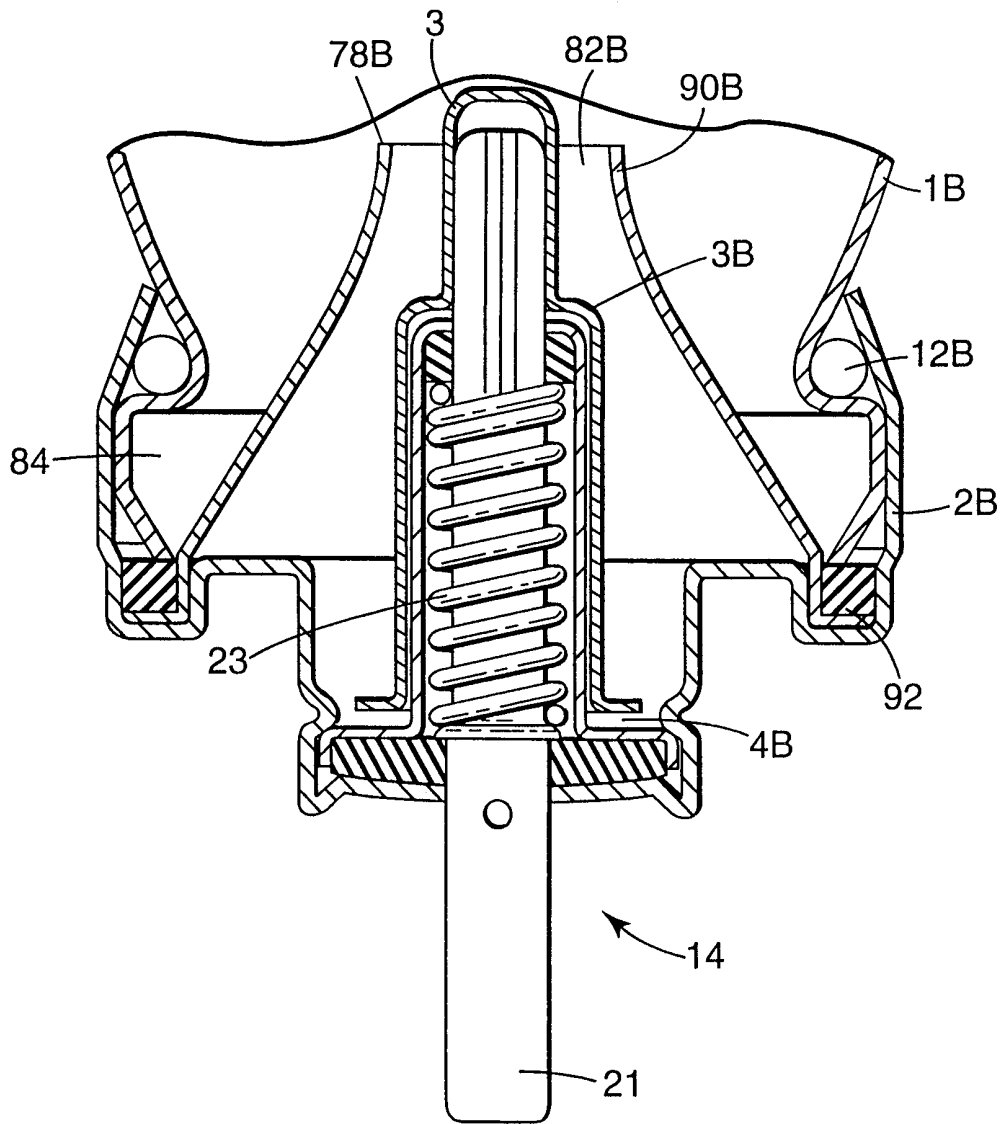

Fig. 2

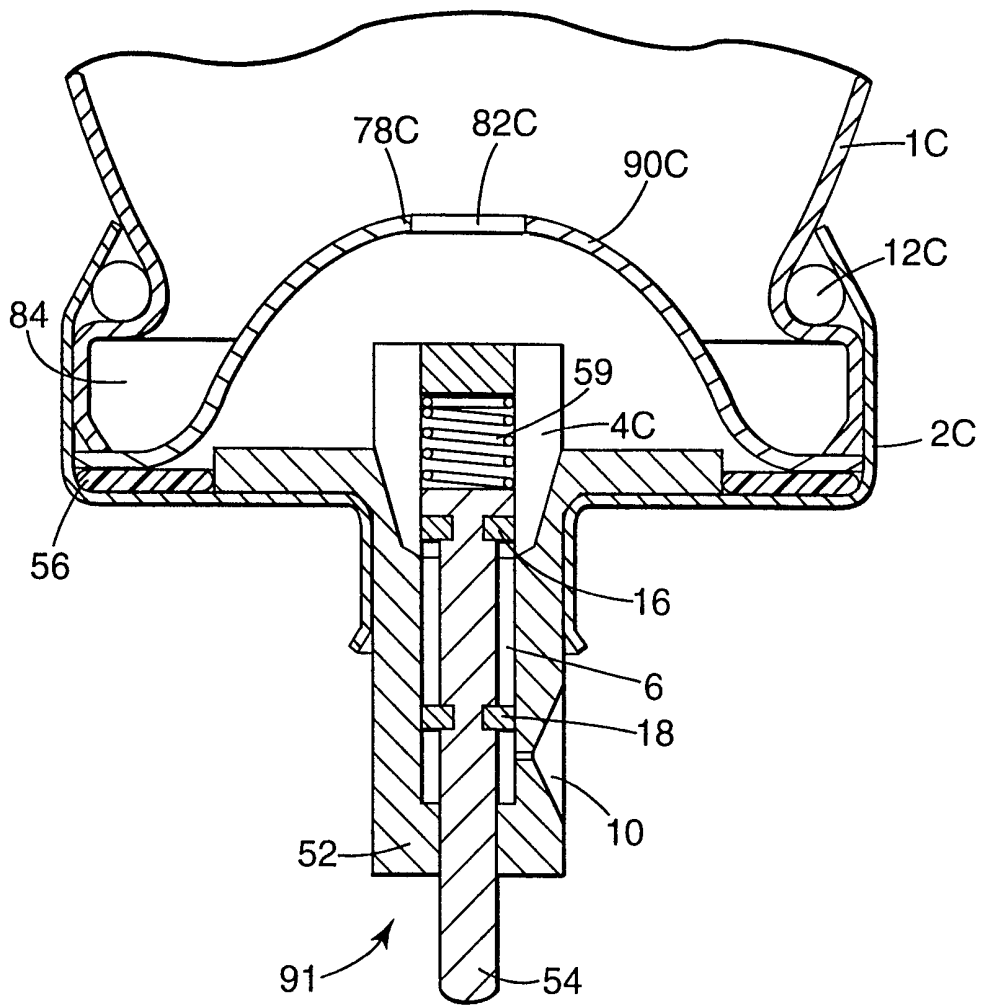

Fig. 3

INTERNATIONAL SEARCH REPORT

International Application No

PCT/US 99/01004

A. CLASSIFICATION OF SUBJECT MATTER
IPC 6 B65D83/54

According to International Patent Classification (IPC) or to both national classification and IPC

B. FIELDS SEARCHED

Minimum documentation searched (classification system followed by classification symbols)

IPC 6 B65D

Documentation searched other than minimum documentation to the extent that such documents are included in the fields searched

Electronic data base consulted during the international search (name of data base and, where practical, search terms used)

C. DOCUMENTS CONSIDERED TO BE RELEVANT

Category °	Citation of document, with indication, where appropriate, of the relevant passages	Relevant to claim No.
A	US 4 944 433 A (KNECHT ADOLF ET AL) 31 July 1990 cited in the application see the whole document ---	1,2,5,6, 9-14
A	EP 0 801 009 A (BESPAK PLC) 15 October 1997 see the whole document ---	1,2,5,6, 9,14
P,A	EP 0 870 699 A (MINNESOTA MINING & MFG) 14 October 1998 see column 20, line 10 - column 21, line 35; figures 18-20 ---	1,9
P,A	US 5 775 321 A (ALBAND TODD D) 7 July 1998 -----	

Further documents are listed in the continuation of box C.

Patent family members are listed in annex.

° Special categories of cited documents :

- "A" document defining the general state of the art which is not considered to be of particular relevance
- "E" earlier document but published on or after the international filing date
- "L" document which may throw doubts on priority claim(s) or which is cited to establish the publication date of another citation or other special reason (as specified)
- "O" document referring to an oral disclosure, use, exhibition or other means
- "P" document published prior to the international filing date but later than the priority date claimed

- "T" later document published after the international filing date or priority date and not in conflict with the application but cited to understand the principle or theory underlying the invention
- "X" document of particular relevance; the claimed invention cannot be considered novel or cannot be considered to involve an inventive step when the document is taken alone
- "Y" document of particular relevance; the claimed invention cannot be considered to involve an inventive step when the document is combined with one or more other such documents, such combination being obvious to a person skilled in the art.
- "&" document member of the same patent family

Date of the actual completion of the international search

3 June 1999

Date of mailing of the international search report

10/06/1999

Name and mailing address of the ISA

European Patent Office, P.B. 5818 Patentlaan 2
NL - 2280 HV Rijswijk
Tel. (+31-70) 340-2040, Tx. 31 651 epo nl,
Fax: (+31-70) 340-3016

Authorized officer

SERRANO GALARRAGA, J

INTERNATIONAL SEARCH REPORT

Information on patent family members

International Application No PCT/US 99/01004

Patent document cited in search report	A	Publication date		Patent family member(s)	Publication date
US 4944433	A	31-07-1990		DE 3802498 A	03-08-1989
				AT 82733 T	15-12-1992
				AU 2891989 A	03-08-1989
				CA 1305002 A	14-07-1992
				CS 276223 B	15-04-1992
				DD 283333 A	10-10-1990
				DK 34989 A	29-07-1989
				EP 0326122 A	02-08-1989
				FI 890399 A, B,	29-07-1989
				GR 3006714 T	30-06-1993
				HR 940722 A	28-02-1997
				IE 63789 B	14-06-1995
				JP 2004683 A	09-01-1990
				JP 2516672 B	24-07-1996
				KR 9706096 B	23-04-1997
				MX 170459 B	24-08-1993
				PH 25445 A	01-07-1991
				PT 89559 A, B	04-10-1989
				SI 8910189 A, B	31-08-1997
				SU 1679975 A	23-09-1991
	YU 18989 A	31-10-1991			
EP 0801009	A	15-10-1997		GB 2311982 A	15-10-1997
EP 0870699	A	14-10-1998		AU 698364 B	29-10-1998
				AU 5185396 A	02-10-1996
				CA 2213442 A	19-09-1996
				EP 0813490 A	29-12-1997
				JP 11501892 T	16-02-1999
				WO 9628367 A	19-09-1996
				US 5772085 A	30-06-1998
US 5775321	A	07-07-1998		AU 695969 B	27-08-1998
				AU 6665994 A	21-11-1994
				CA 2161632 A	10-11-1994
				DE 69406916 D	02-01-1998
				DE 69406916 T	25-06-1998
				EP 0697002 A	21-02-1996
				EP 0796805 A	24-09-1997
				ES 2109696 T	16-01-1998
				JP 8509689 T	15-10-1996
	WO 9425373 A	10-11-1994			