

(No Model.)

T. J. LINDSAY & W. J. MINER.

CORN PLANTER.

No. 246,162.

Patented Aug. 23, 1881.

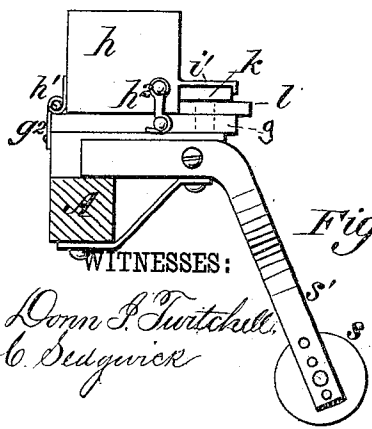
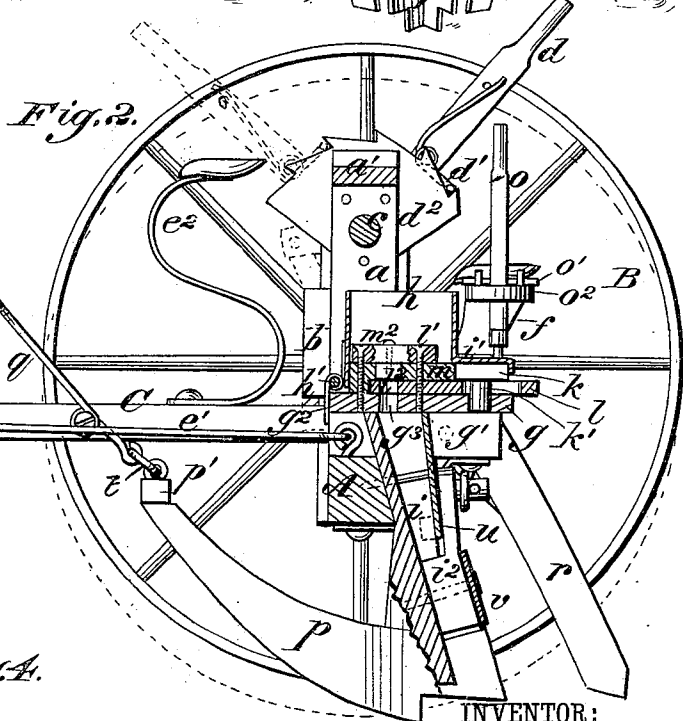
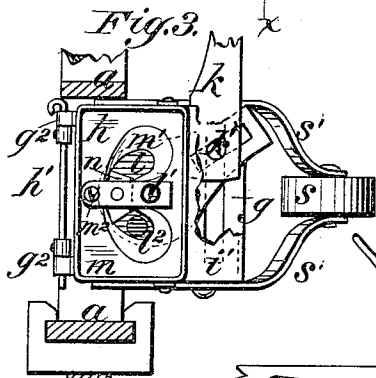
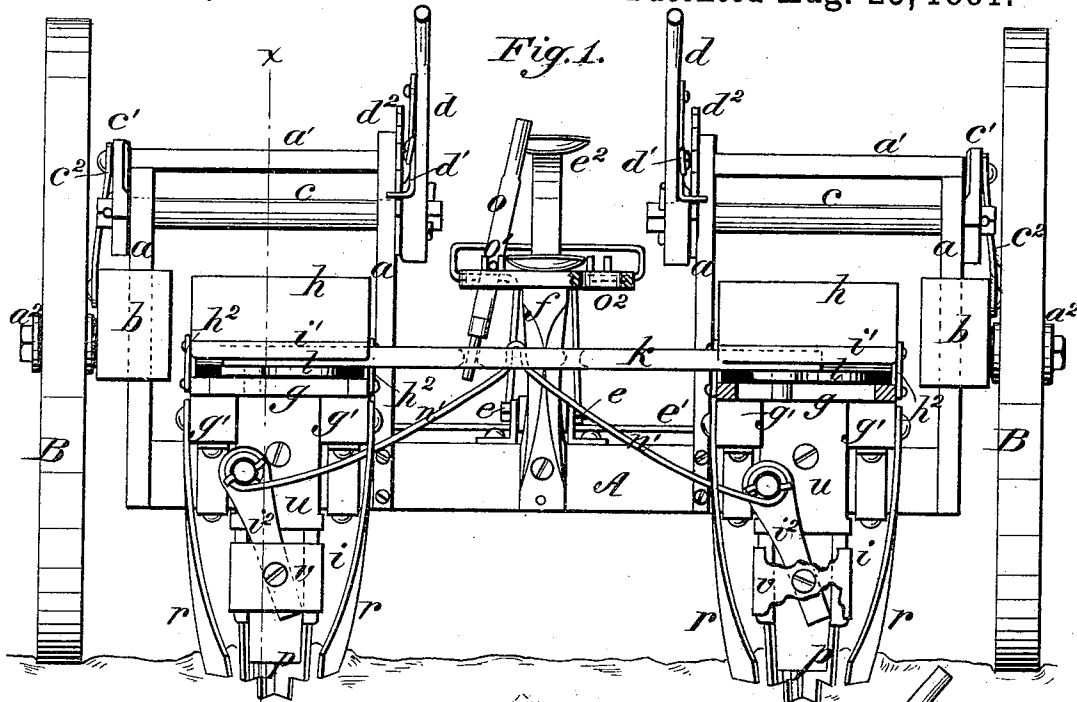

WITNESSES:

Donn S. Twitchell,  
C. Sedgwick

INVENTOR:

T. J. Lindsay  
W. J. Miner

BY

ATTORNEYS.

# UNITED STATES PATENT OFFICE.

THOMAS J. LINDSAY AND WILLIAM J. MINER, OF WINDFALL, INDIANA.

## CORN-PLANTER.

SPECIFICATION forming part of Letters Patent No. 246,162, dated August 23, 1881.

Application filed September 8, 1880. (No model.)

*To all whom it may concern:*

Be it known that we, THOMAS J. LINDSAY and WILLIAM J. MINER, of Windfall, in the county of Tipton and State of Indiana, have invented a new and useful Improvement in Corn-Planters, of which the following is a specification.

In the drawings, Figure 1 is a rear elevation of the machine. Fig. 2 is a vertical section on line *xx* of Fig. 1. Fig. 3 is a plan view of one seed-box and covering-roller, and Fig. 4 is a side elevation of the seed-box.

Similar letters of reference indicate corresponding parts.

The object of our invention is to furnish an improved corn-planter; and our invention consists in the combination and arrangement of parts, as hereinafter fully described.

A is the axle-tree or cross-bar of the frame, upon each end of which there are fixed standards *a*, braced by top plates, *a'*.

B B are the wheels upon short spindles *a*<sup>2</sup>, that are fixed on blocks *b*, which are mortised upon the outer standards, *a*, so as to slide thereon and permit movement of axle A and its attached parts upon the wheels.

In the upper part of standards *a* rock-shafts *c* *c* are fitted, carrying arms *d* *d* at their inner ends for their operation by hand, and having their outer ends provided with arms *e'* *e'*, that connect by rods *e*<sup>2</sup> *e*<sup>2</sup> with blocks *b*. The arms *d* carry pawls *d'*, that engage with notched plates *d*<sup>2</sup>, that are fixed on the inner standards, *a*, for the purpose of holding the shafts *c* *c* in position as turned to raise the axle.

C is the tongue, hinged between lugs *e*, that are attached to axle A; and *e'* are hinged braces to the axle from tongue C. The tongue carries a seat, *e*<sup>2</sup>, for the driver, and there is also a seat carried by a standard, *f*, that projects backward from the axle, for the attendant who operates the dropping-slides. The seed-boxes and dropping mechanism are fitted on axle A, between the standards *a* at each side, and the following description applies to either.

Upon short bars *g'* *g'*, that are fixed on the axle A, is fixed a plate, *g*, forming the bottom of the seed-box *h*, and having a central aperture, *g*<sup>2</sup>, for escape of grain to the spout *i*, that is attached between the bars *g'*. The seed-box *h* is held to the forward edge of plate *g* by

a hinge-pin, *h'*, that passes through apertured lugs *g*<sup>2</sup> on the plate and box, so that the box can be raised and turned forward to give access to the feed-slides. The box is held down by pivoted catches *h*<sup>2</sup> at the back taking over pins on plate *g*; and the rear part of the box *h*, as shown most clearly in Fig. 4, is formed with a flange, *i'*, that serves as a guide for the cross-bar *k*, by which the slides are moved.

Upon plate *g* a vibrating slide, *l*, is fitted on a fixed pin, *l'*, which slide is provided with two apertures, *l*<sup>2</sup>, and has its rear end extending outside the box *h*. This end of slide *l* is slotted to receive a pin, *k'*, from bar *k*, and said pin extends into a straight slot in plate *g*, so that the bar *k* is guided in its movement.

In box *h*, above plate *l*, is fixed a plate, *m*, having a slot, *m'*, formed in the arc of a circle from pin *l'*.

Above plate *m* is fixed a bar, *m*<sup>2</sup>, that crosses slot *m'* and supports a beveled piece, *n*, in the slot *m'*, which serves as a cut-off for the apertures *l*<sup>2</sup> of the slide *l*, so that while the grain in box *h* has access to one aperture, *l*<sup>2</sup>, through slot *m'* in plate *m*, the other is beneath the piece *n* and above the aperture *g*<sup>2</sup> of plate *g*.

The spouts *i* are covered at the back by plates *uv*, attached by screws, so that they may be readily removed to give access to the spouts.

In the lower part of spout *i* is fitted a valve consisting of an arm, *v*<sup>2</sup>, pivoted to swing cross-wise of the machine by a pin at the center of the spout, and having its lower end formed to close the spout at both extremes of movement. By this construction the grain discharged at each movement of slide *l* is caught by valve *v*<sup>2</sup>, and held near the discharge end of the spout until the next movement of the slide, so that the grain can be dropped more exactly at the desired place. The valve *v*<sup>2</sup> is connected by a rod, *n'*, to the bar *k*, so as to be moved thereby. The slide-bar *k* is fitted for operation by a lever, *o*, that is hung by a fulcrum-pin, *o'*, in a slotted plate, *o*<sup>2</sup>, fixed on the standard *f* of axle A, by which lever the bar *k* can be reciprocated to operate both slides *l* and valves *v*<sup>2</sup> simultaneously.

The openers *p* consist of curved plates having their lower bifurcated ends attached at opposite sides of the spouts *i*, and their forward ends connected to a cross-bar, *p'*, that is con-

5 nected by links to the lower ends of a forked foot-lever, *q*, hung on tongue C. The tongue C and its braces being hinged to axle A, the movement of lever *q*, by raising and lowering bar *p'*, tilts the axle A. The openers can thus be readily passed over obstacles, and in hard ground the driver can hold lever *q* down with his feet, so that the openers shall enter properly.

10 The coverers, as shown in Figs. 1 and 2, consist of curved drag-plates *r r*, attached to the rear ends of the bars *g'*, and extending down behind the spouts *i*. The lower ends curve inward, so that they gather the soil between them and form a loose ridge.

15 In Figs. 3 and 4 we have shown a covering-roller, *s*, that can be used instead of drags *r*. This roller is carried by arms *s' s'*, so that it runs on the ground behind the spout. The drag-plates *r* and the arms *s'*, carrying roller *s*, are pivoted to the bars *g'* by a single bolt, so that they are adjustable and may be readily removed.

20 With the above-described machine the grain can be dropped regularly in two rows at once. By turning the arms *d* the axle A, with its at-

tached parts, can be raised to regulate the depth of planting, and one side raised more than the other, if required. In case the openers *p* strike an obstruction, the axle will rise and the arms *d* will engage and hold the machine up until the obstruction is passed; or the operator can raise the axle by means of arms *d*, so as to pass obstructions.

35 Having thus described our invention, what we claim as new, and desire to secure by Letters Patent, is—

In a corn-planter, the combination, with the hinged seed-box provided with the flange *i'*, the standard *f*, and the axle A, of the bottom plate, *g*, having a central aperture, *g<sup>3</sup>*, the vibrating slide *l*, provided with apertures *l<sup>2</sup>* and a slotted extension, the fixed plate *m*, provided with the slot *m'*, the bar *m<sup>2</sup>*, the beveled piece *n*, the bar *k*, provided with pin *k'*, the lever *o*, the pin *o'*, and the slotted plate *o<sup>2</sup>*, substantially as and for the purpose described.

THOMAS JEFFERSON LINDSAY.  
WILLIAM JEFFERSON MINER.

Witnesses:

JACOB BARROW,  
MELVILLE MINER.