



HU000032163T2

(19) **HU**(11) Lajstromszám: **E 032 163**(13) **T2****MAGYARORSZÁG**
Szellemi Tulajdon Nemzeti Hivatala**EURÓPAI SZABADALOM**
SZÖVEGÉNEK FORDÍTÁSA

(21) Magyar ügyszám: **E 15 151589** (51) Int. Cl.: **E04C 2/12** (2006.01)
(22) A bejelentés napja: **2015. 01. 19.** **B27M 3/00** (2006.01)
E04C 2/40 (2006.01)
(96) Az európai bejelentés bejelentési száma: **E04C 3/12** (2006.01)
EP 20150151589 **E04C 3/14** (2006.01)
(97) Az európai bejelentés közzétételi adatai:
EP 2896761 A1 **2015. 07. 22.**
(97) Az európai szabadalom megadásának meghirdetési adatai:
EP 2896761 B1 **2016. 12. 21.**

(30) Elsőbbségi adatok: MI20140069 2014. 01. 21. IT	(73) Jogosult(ak): Leneco S.r.l., 39100 Bolzano (BZ) (IT)
(72) Feltaláló(k): Hofer, Paulpeter, 39100 Bolzano (IT)	(74) Képviselő: Danubia Szabadalmi és Jogi Iroda Kft., Budapest

(54) **Modulrendszerű alapelem, továbbá ilyen alapelemekből kialakított hosszelem, panel és tábla**

Az európai szabadalom ellen, megadásának az Európai Szabadalmi Közlönyben való meghirdetésétől számított kilenc hónapon belül, felszólalást lehet benyújtani az Európai Szabadalmi Hivatalnál. (Európai Szabadalmi Egyezmény 99. cikk(1))

A fordítást a szabadalmas az 1995. évi XXXIII. törvény 84/H. §-a szerint nyújtotta be. A fordítás tartalmi helyességét a Szellemi Tulajdon Nemzeti Hivatala nem vizsgálta.

(19)



(11)

EP 2 896 761 B1

(12)

EUROPEAN PATENT SPECIFICATION

(45) Date of publication and mention of the grant of the patent:
21.12.2016 Bulletin 2016/51

(51) Int Cl.:
E04C 2/12 (2006.01) *E04C 2/40* (2006.01)
B27M 3/00 (2006.01) *E04C 3/12* (2006.01)
E04C 3/14 (2006.01)

(21) Application number: **15151589.7**

(22) Date of filing: **19.01.2015**

(54) **Modular base element as well as longitudinal member, board and panel formed by such base elements**

Modulares Basiselement sowie Längsträger, Bohle und Tafel aus solchen Basiselementen

Élément modulaire de base ainsi que longeron, planche et panneau formés de tels éléments de base

(84) Designated Contracting States:
**AL AT BE BG CH CY CZ DE DK EE ES FI FR GB
 GR HR HU IE IS IT LI LT LU LV MC MK MT NL NO
 PL PT RO RS SE SI SK SM TR**

(30) Priority: **21.01.2014 IT MI20140069**

(43) Date of publication of application:
22.07.2015 Bulletin 2015/30

(73) Proprietor: **Leneco S.r.l.
 39100 Bolzano (BZ) (IT)**

(72) Inventor: **Hofer, Paulpeter
 39100 Bolzano (IT)**

(74) Representative: **Raimondi, Margherita
 Dott. Ing. Prof. Alfredo Raimondi S.r.l.,
 Piazzale le Cadorna, 15
 20123 Milano (IT)**

(56) References cited:
**WO-A1-00/45006 WO-A1-00/77319
 DE-C- 835 646 DE-U1- 29 610 829
 GB-A- 1 212 052 US-A- 5 079 894**

EP 2 896 761 B1

Note: Within nine months of the publication of the mention of the grant of the European patent in the European Patent Bulletin, any person may give notice to the European Patent Office of opposition to that patent, in accordance with the Implementing Regulations. Notice of opposition shall not be deemed to have been filed until the opposition fee has been paid. (Art. 99(1) European Patent Convention).

Description

[0001] The present invention relates to a modular base element, longitudinal member, board and panel with low heat conductivity and improved three-dimensional stability with respect to externally and/or internally acting forces, in particular for the construction of walls and/or flooring of buildings.

[0002] It is known, in the technical sector of the wood building industry that the perimetral constructional components, such as the outer walls, must have various physical and mechanical characteristics in order to meet the various requirements of the sector and in particular: optimum air tightness, static stability, resistance to atmospheric agents and sound-proofing properties, as well as low vapour permeability and heat conductivity and high fire resistance.

[0003] It is also known that the various characteristics of the constructional component influence each other, also in opposition to each other, and must be considered as a whole during the design stage, in particular as regards the through-holes in the external constructional components or the mating points and/or joints with other constructional components.

[0004] At present the manufacture of an external wooden wall which meets said requirements is possible only by assembling several constructional layers which perform individual well-defined functions which are directly related to the sought-after effect; examples of these single layers are: static structures, vapour check layers and/or barriers, wind-stopper films, additional heat insulation layers, inner and outer cladding with a cavity for inserting service installations such as electrical connections and/or ventilation/air-conditioning ducts.

[0005] These known technologies, however, result in structurally complex and costly structures and at the same time give rise to constructional defects and resultant damage to the building.

[0006] It is also known that a further major problem affecting constructional components made of solid wood consists in the relatively high heat conductivity of the latter, which has the effect that, in order to construct an external wall made of solid wood for low-energy buildings, high wall thicknesses are required, with the result that the constructional components have a high thickness and weight and are unduly costly; consequently the walls are usually made with the thickness needed to ensure the necessary statics and then completed with the addition of insulation layers.

[0007] A further known problem of all solid-wood structures consists in the shrinkage or swelling of the wood caused by the variations in the moisture content of the wood itself; in greater detail, the wood, and generally the organic materials which are increasingly used as building materials, have special characteristics in that their physical properties are structured differently in the three anatomical directions of the wood, i.e. longitudinal direction (direction of the veining), radial direction (direction of

trunk growth) and tangential direction (relative to the annular growth ring), namely as regards both the load-bearing capacity and swelling and shrinkage of the wood resulting from variations in the moisture content thereof; it is also known that, while the influence of said environmental factors is not significant in the direction of the veining of the wood, the same factors instead have a major effect on the variations in the dimensions transverse to the said veining (approximate ratios = 1:10:20), said variations being also distinguishable in terms of direction and type of veining (radial or axial relative to the core of the trunk, which also differ depending on the alburnum or duramen).

[0008] Without having to resort to major constructional measures, there exist substantially two possibilities for limiting the problem of the dimensional variations of the wood in solid-wood constructional components:

a) in the case of panels composed of boards which are joined together, it is avoided forming the joint by means of a force-fit of the single boards so as to leave a certain "play" between them and thus allow deformation, without, however, the entire component being subject to a major variation in the dimensions.

b) in the case of panels consisting of laminated wood or multi-layer panels, the panel is fixed by joining together sheets which are superimposed alternately so that the fibres intersect each other (multi-layer panels, for example, *Kreuzlagenverbundholz*).

[0009] Although fulfilling their function these known methods, however, are unable to prevent the wooden component from shrinking or expanding in any case in the third direction (perpendicularly with respect to the panel). This constructional problem arises in particular in the case of angular components (owing to the formation of gaps) and more particularly when there is an increase in the thickness of the board, and therefore especially in the case of high-thickness solid-wood structures.

[0010] Further drawbacks associated with solid-wood constructional components of the known type arise from the fact that the wind, air and moisture permeability characteristics of said components do not always ensure a hermetic seal over time of the structural joints, especially in the case of systems where each individual component is subject individually to the deformations arising from the natural shrinkage and swelling of the wood.

[0011] Although in the case of solid-wood, glued, multi-layer constructional components the impermeability of the individual components is ensured, the shrinkage and swelling have a significant influence on the dimensions of the entire component, transversely with respect to the veining. The joints which are formed between the single constructional components which are subject to deformation must consequently be properly sealed, in view of the significant movements of the single components rel-

ative to each other. There exist on the market various solid-wood board systems for walls and floor components made using a multi-layer construction system, such as *Kreuzlagenholz* (KLH), *Dickholz* (Finnforest-Merk), *Thoma-Massivholzwand*, *MassivHolzMauer* (MHM); these are formed by several layers of solid-wood boards such that the wood veining of the single layers or all the layers of the boards are arranged diagonally or orthogonally relative to each other and the layers are joined together by means of joining elements (glue, wooden plugs, metal elements) such that the elements are constrained in both directions of the board with the effect of minimizing shrinking and swelling of the wood.

[0012] Also known in the sector are solid-wood components formed as boards or monobloc structures (*Blockbauweise*) in which the wood veining of the single layers (planks, beams, boards or battens) is arranged in a single direction perpendicular to the direction of the boards.

[0013] The single wooden elements are joined together by means of glue, plugs, wooden plugs and/or wooden elements.

[0014] As regards the problem of shrinkage and swelling of the wood, in such cases constructional measures for the building must be adopted (such as the so-called block building system for glued laminated board and laminated wood structures) or the constructional components must be assembled so that they cannot be force-fitted together and each component manages to absorb the resultant deformations, while keeping the total length and width of the wooden component in question more or less stable.

[0015] This effect is achieved with additional barrier layers or elements having plugs arranged in a particular manner, metal elements or plastic elements, etc.

[0016] A special variant is the composite laminated wood structure *Holzlagenverbundplatte*) described in EP 1 734 200 B1 (Reinverbund) and composed of several layers of boards which are arranged in parallel and together with flashing battens). In this case also shrinkage and swelling of the wall or floor constructional component widthwise or lengthwise are avoided, while allowing the single boards to expand freely owing to their associated bilateral joining channels which permit a certain degree of movement and a certain dimensional variation of the single boards.

[0017] Usually the wooden-block components described above have heat insulation properties which are similar to those of solid wood. Improved values are obtained if the joints are not formed using glue: for example the solid-wood walls (*Thoma-Massivholzwände*) described in DE-20208773U1 achieve better values of the heat insulation properties by means of the provision of superficial grooves in the wooden components.

[0018] Another example of embodiment is proposed in EP 1 288 386 A1 (Walch) involving the assembly of various layers of boards, some of which have cavities and/or grooves which should allow improved heat insulation. Al-

so known from EP-1 715 114A2 in the name of the same inventor is another solid-wood component (laminated wooden board component) in which the wall has internal air chambers which should achieve improved temperature gradients of said wall.

[0019] A further type of construction has been described in WO 2011/000120 in which structured wooden components used for the insulation of pillar structures (*Holzständerbauweise*) are composed of laminated elements with grooves.+

[0020] WO 00/77319 A1 discloses a structural base element according to the preamble of claim 1.

[0021] The technical problem which is posed, therefore, is that of providing a building component made of material which is substantially anisotropic with respect to a longitudinal "veining" direction, preferably wood, for external walls, and is able to provide the following characteristics:

-) low deformation of the building component due to shrinkage and swelling of the wood compared to solid wood, such that there are no weak points in the joints;
-) in the ideal case, all the necessary physical characteristics such as: heat insulation, structural strength, sound-proofing, hermetic seal can be achieved using a few uniform constructional components;
-) a substantially low heat conductivity coefficient compared to solid-wood components, namely improved resistance to heat conductivity;
-) suitability for ensuring correct natural convection of water vapour.

[0022] In connection with this problem it is also required that the wooden building component should be:

-) able to be produced using wooden components which are low-weight and low-thickness, so as to allow easier handling and low-cost transportation, and which may be easily dried and are suitable for low-cost industrial processing;
-) suitable for easy finishing if required;
-) able to ensure formation of the external façade surface and inner surface adaptable as far as possible to the external finish, leaving the end user with the possibility of choosing whether to leave the wood visible, whether to apply cladding of any type, whether to paint the wall, or the like.

[0023] These results are obtained according to the present invention by a modular base element made of wood or the like according to the characteristic features of Claim 1.

[0024] The present invention relates furthermore to a longitudinal member for building structures according to the characteristic features of Claim 14 and to a composite panel according to the characteristic features of Claim 18.

[0025] Further details may be obtained from the following description of a non-limiting example of embodiment of the subject of the present invention, provided with reference to the accompanying drawings, in which:

Figure 1: shows a perspective view of a trunk with, highlighted, the respective veining lines and a board still inserted inside it;

Figures 2a,2b: show, respectively, a partially sectioned perspective view of a first embodiment of a modular base element according to the present invention and the detail of the associated cross-section;

Figures 3a-3d: show, respectively, a first and second variation of embodiment of the base element according to Figure 2;

Figures 4a,4b: show, respectively, a partially sectioned perspective view of a second embodiment of a modular base element according to the present invention and the detail of the associated cross-section;

Figure 5: shows a variation of the embodiment of the base element according to Figure 4;

Figures 6a,6b: show, respectively, a partially sectioned perspective view of a third embodiment of a modular base element according to the present invention and the detail of the associated cross-section;

Figure 7: shows variations of embodiment of the base element according to Figure 6;

Figure 8: shows cross-sections through different embodiments of longitudinal members obtained from the joining together of different base elements;

Figure 9: shows a perspective view of a first example of embodiment of a panel according to the present invention;

Figure 10: shows a perspective view of a panel according to the invention with barrier layers as external closing surfaces;

Figure 11: shows a perspective view of a second embodiment of the panel according to Figure 10 with ventilation and receiving ducts for service installations;

Figure 12: shows a perspective view of a second embodiment of a panel according to the invention provided with external closing surfaces;

Figure 13: shows a perspective view of an embodiment of a panel according to the invention with external barrier layers formed by panels positioned orthogonally with respect to the panel itself;

Figure 14: shows a perspective view of an embodiment of a panel according to the invention with internal barrier layers;

Figure 15: shows a perspective view of a constructional example with walls formed by panels according to the present invention with internal and external barrier layers as cladding;

Figure 16: shows a schematic view of the deforma-

tions of a panel according to the invention subject to the action of an external force in a direction perpendicular to the direction of the veining;

Figure 17: shows a schematic view of the deformations of a panel according to the invention deformed by shrinkage of the wood owing to a reduction in the moisture content thereof;

Figure 18: shows a schematic view of the deformations caused by shrinkage of the wood due to a reduction in the moisture content thereof in a panel according to the invention with barrier layers in one of the directions perpendicular with respect to the direction of the veining;

Figs. 19-27: show examples of boards for the formation of panels according to the invention with respective machined designs.

[0026] For the purposes of the present invention the following definitions will be used:

MODULAR BASE ELEMENT = modular base element made of a material, for example wood, substantially anisotropic in a longitudinal direction obtained preferably from a plant; below also referred to as "base element";

LONGITUDINAL MEMBER = module formed by the joining together of several base elements extending in the longitudinal direction (X-X);

[0027] PANEL = supporting element (such as a wall, ceiling or roof) of a structure, made of wood or different material substantially anisotropic in a longitudinal direction and provided with cavities extending in the longitudinal direction.

[0028] BOARD = modular element formed from regular and/or irregular cuts of a panel design and suitable for the formation of panels.

[0029] It is understood that, for the purposes of the invention, the terms "formed by the joining together of" and "comprising" are **to be** understood in **either a physical or geometrical** sense.

[0030] As shown in Fig. 1, a wooden modular base element 10 is obtained from a trunk 1 with veining 1a which is visible also on the base element itself; below, for easier description and without a limiting meaning, a set of three reference axes will be assumed, said axes having given directions, irrespective of the orientation of the figures, namely: a longitudinal direction X-X, parallel to the direction of the veining 1a, or anisotropy, of the base element; transverse direction Y-Y, perpendicular to the said veining and corresponding to the width of the base element 10; and vertical direction Z-Z perpendicular to the plane of the other two axes. The base element 10, after suitable machining, in a first embodiment will have (Fig. 2):

FIGS. 2+3**[0031]**

-) a first flange 11, an outer surface 11a of which is flat and the other, inner, surface 11b of which, situated opposite the first surface, has a web 12 extending outwards and forming the element for joining with the inner surface 13b of a second flange 13 parallel to the first flange 11 and with an associated flat outer surface 13a.

[0032] As shown in Fig. 2b, the first flange 11 and the second flange 13 have their respective free edges 11c, 13c projecting, in the transverse direction (Y-Y) perpendicular to the veining direction and contained within the plane, beyond the end bounded by the web 12 of the other flange 13, 11 and in opposite directions to each other, by a suitable amount (D), preferably, but not necessarily the same for both flanges.

[0033] In its zones respectively adjacent to the flanges 11 and 13, the web 12 is hollowed out internally so as to form, respectively, a first recess 12a and a second recess 12b extending in the transverse direction Y-Y and open in both senses towards the outside.

[0034] The geometrical form of the base element is therefore such as to define an inclined theoretical web (indicated by broken lines), resulting in a cross-section of the base element extending in a substantially Z-shaped manner; the inclination of the web 12 is defined by a first angle α relative to the upper flange 11 and by a second angle β relative to the second flange 13, which are preferably, but not necessarily, equal to each other.

[0035] As shown in Figs. 3a,3b, the different depth (Y-Y) and height (Z-Z) of the recesses 12a,12b determine different shapes - which are qualitatively equivalent - of the base element.

FIGS. 4+5

[0036] Figs. 4a,4b show a further variation of embodiment of the base element 210 which has in this case:

a first flange 11 and a second flange 13 as in the preceding example; the two flanges have, formed between them, a joining web 212, projecting from the inner surface 11b of the first flange from one of the two end edges thereof and inclined towards the second flange 13 to which it is connected at its end edge.

[0037] In this case also, the opposite free end edges 11c and 13c of the two flanges 11 and 13 extend by an amount "D" beyond the opposite corners connecting together the web and the two flanges.

[0038] This configuration results in the formation of:

- a first recess 212a lying between the first flange 11

and the web 212;

- a second recess 212b lying between the said web 212 and the second flange 13.

[0039] Preferably the inclination of the theoretical webs 12 and 212 relative to the two flanges 11 and 13 has angles α and β which are smaller than 90° , preferably ranging between 15° and 75° and even more preferably ranging between 40° and 60° .

[0040] Fig. 5 shows variations of exemplary embodiments with different chamfering of the geometrical form of the base element shown in Fig. 4; the variations in shape are not described in detail since they have the same characteristics which are common to all the base elements according to the invention, as may be established by the person skilled in the art.

FIGS. 6+7

[0041] In a further variation of embodiment derived from the embodiment shown in Fig. 4a, the base element 310 has:

-) a first spoiler 311 connected to the first flange 11 at its free end 11c and facing the second flange 13; the spoiler 311 has an outer surface 311a parallel to the vertical direction Z-Z and inner surface 311b inclined parallel to the first web 212;

-) a second spoiler 313 with a substantially triangular cross-section, having a base 313a joined to the free edge of the second flange 13; the outer side 313a of the spoiler 313 is parallel to the vertical direction Z-Z and the inclined side 313b is substantially parallel to the web 212.

[0042] Fig. 7 shows exemplary embodiments with variations in the geometrical form of the base element shown in Fig. 6; the embodiments are not described in detail since they have the same characteristics which are common to all the base elements according to the invention, as may be established by the person skilled in the art.

LONGITUDINAL MEMBER

[0043] As shown in Fig. 8 it is possible to provide longitudinal members 500a-500n extending in the longitudinal direction X-X of veining 1a and formed by the joining together of base elements 10,210,310 identical to each other (500a - 5001), but also different (500m,500n), these being joined along the outer surface 11a, 13a of the respective base flanges 11,13 and/or the free edges parallel to the vertical direction Z-Z and in the following manner:

- a first pair (not necessarily formed by two identical modular base elements) joined in a mirror-image arrangement along a first direction perpendicular to the direction X-X,

- a second pair (not necessarily formed by two identical modular base elements and not necessarily identical to the first pair) joined along the same first direction perpendicular to the direction X-X,
- the two pairs being joined together in a mirror-image arrangement along the other direction perpendicular to the veining so as to form a longitudinal cavity 501a-501n containing four angles between flanges and theoretical webs such as to define inclined theoretical webs inclined and converging towards the centre of the cavity.

[0044] It is understood that the combinations shown are non-exhaustive exemplary embodiments of the various possibilities.

[0045] The common element which characterizes the longitudinal members 500 consists of the said internal cavity 501a-501n extending in the longitudinal direction X-X and formed by the joining together of the recesses 12a-12b; 212a-212b; 312a-312b of the different base elements 10,210,310.

[0046] The cross-section of the longitudinal cavity is approximately in the form of an hour-glass, X-shaped, I-shaped or with irregular shapes, but all of these being such as to maintain a structure with theoretical inclination webs always directed inwardly and converging towards the centre of the said cavity and designed to ensure special dynamic behavioural responses, as will be described more fully below.

PANEL FIGS. 9-14

[0047] Fig. 9 shows an example of a panel 1001 according to the invention which comprises longitudinal members arranged alongside each other in one direction Y-Y of the two directions Y-Y;Z-Z perpendicular to the longitudinal direction X-X and which has X-shaped cavities 1501 extending in the longitudinal direction X-X of the veining 1a.

[0048] It is understood that the smallest size panel will comprise only two longitudinal members arranged alongside each other in one or the other of the transverse direction Y-Y or vertical direction Z-Z perpendicular to the longitudinal direction X-X of the veining 1a.

[0049] The panel will generally comprise several rows of longitudinal members arranged alongside each other, thus defining panels according to the invention with cavities arranged aligned in rows or columns along one of the two directions perpendicular to the direction X-X, each row or column being staggered, by half a cavity in the other direction perpendicular to the direction X-X, with respect to the adjacent row or column.

[0050] Fig. 10 shows a further example of a panel, similar to that of Fig. 9, but completed with closing surfaces 201 applied to the opposite free surfaces 11a and 13a of the flanges 11 and 13 so as to provide a surface finish. According to preferred embodiments, these closing surfaces 201 may also be designed to function as a barrier

layer/element in a direction perpendicular to the direction X-X, as will be described more fully below, or also as a layer for improving the static resistance.

[0051] Fig. 11 shows a further embodiment of a panel according to the invention with closing surfaces 201 and ducts 1251 for the air flow and/or for housing service installations such as electrical connections 1251a.

[0052] Fig. 12 shows a further embodiment of a panel with longitudinal cavities in the form of an hour-glass.

[0053] In addition to the special arrangement of the cavities it is also envisaged using a barrier element arranged perpendicularly to only one of the directions transverse to the direction of the veining 1a of the wood; by means of the barrier element and the particular cavity and web structure of the panel dimensional variations of the latter are blocked in both the senses transverse to the direction of the wood veining, as will become clearer below.

[0054] Fig. 13 shows a panel 1101, similar to the panel 1001 shown in Fig. 9, to which two barrier layers 1050 have been applied, on the opposite outer surfaces of the flanges 1011a and 1013b; in the preferred example of Fig. 13 the barrier layers are also composed of panels similar to those described in Fig. 9; it can be noted how the barrier layers 1050 are applied in directions of the veining 1051a perpendicular to the directions of the longitudinal veining 1a of the panel.

[0055] Fig. 14 shows a panel with internal barrier layers 1150, namely parallel to the vertical direction Z-Z.

WALLS

[0056] Figure 15 shows an example of a building structure where the walls are made with panels 1000 according to the invention having continuous cavities extending parallel to the direction of the veining 1a and arranged rotated so as to position said cavities so that they are open in the vertical direction Z-Z; it is envisaged however also being able to provide cavities open in the horizontal direction of said wall, if required for statics-related reasons, for example in the case of floor structures.

[0057] This configuration of the panel 1000 produces therefore an important technical effect with regard to the heat conduction of the walls of the building structure: in fact, leaving aside the heat passage through the cavities, the heat flow which passes through the cross-section of the wood in the transverse direction Y-Y perpendicular to the longitudinal direction X-X of the veining (in Figure 15 corresponding to the vertical direction Z-Z) and to the joining direction of the longitudinal members, diminishes considerably since it is forced to follow a long path only across the flanges 11,13 and associated connecting webs 12,212,312.

[0058] With this configuration the heat flow from the outside to the inside and vice versa is therefore forced mainly along only the solid parts of the panel, thus being reduced and favouring an increased insulation capacity.

DEFORMATIONS

[0059] A fundamental feature of the panels according to the invention consists in the fact that the cavity and inclined web sequences give rise to a dimensional variation which is always uniform in both directions, i.e. transverse direction Y-Y and vertical direction Z-Z, perpendicular to the longitudinal direction X-X of the veining.

[0060] The webs and their joining points form within the cross-section a bar system which is highly undefined from the point of view of statics, being prone to deform when subject to the action of forces.

[0061] Leaving aside the compression or elongation of the webs under pressure due to application of an external force and allowing resilient rotation of the webs relative to each other in the nodes formed by the intersection between two consecutive inclined webs and the flange included between them, the panel and its joining points behave as follows and as illustrated in Figs. 16-18:

-) based on the static situation shown in Fig. 16a in which the angle β , α and the length (a) of the flanges and the length (b) of the webs are indicated, the following occurs:

-) the influx of a transverse external force (pressure) Y-Y applied perpendicularly with respect to the veining 1a, for example on the superficial closing side of the panel, causes not only compression of the panel in the direction of the force, but also a simultaneous compression of the panel perpendicularly with respect to the plane which contains both the force and the longitudinal direction of the veining; i.e. deformations dz and dy occur along both the respective directions Z-Z and Y-Y perpendicular to the veining, due to the modification of the angles between flanges and webs, caused by the external force.

[0062] A similar simultaneous deformation behaviour dy, dz occurs both along Y-Y and along Z-Z (Fig. 17) in the case of internal forces caused by the swelling/shrinkage of the panel due to the variations in the moisture content affecting it (or also the thermal expansion in the case of a variation in temperature); however, in this case, the flanges and webs deform simultaneously, leaving unvaried the angle Q between them (Fig. 17).

[0063] On the other hand, it may be said that, based on the fact that each web of the wooden element, in the event of shrinkage or swelling due to variations in environmental factors, shrinks or expands in a uniform manner, blocking of the movement of the wooden element in one of the directions described, perpendicular to the direction of the veining, causes in turn complete or partial blocking also in the direction (Fig. 18b), this making the entire element stable.

[0064] This also occurs even if only some parts of this wooden element are subject to varying conditions, as for

example in the case where, following local infiltrations, not all the wall, but only part of it becomes damp as a result of being subject to a greater degree of moisture.

5 BARRIER LAYER

[0065] As a result of that mentioned above as well as the special arrangement of the cavities, the use of a barrier element applied to the panel perpendicularly with respect to only one of the directions transverse to the longitudinal direction of anisotropy or veining of the wood, as shown with reference to Figs. 10, 13 and 14 ensures that, via the barrier element and the particular recess and web structure of the panel, externally detectable dimensional variations of the structure due to shrinkage and swelling are prevented in both senses transverse to the direction of the wood veining or generally direction of anisotropy of the material.

[0066] It has also been determined that the internal structure absorbs most of the forces which are generated on the panel as a result of shrinkage and/or swelling of the wood, thus allowing the barrier element to absorb a limited force in order to keep the element stable.

[0067] Fixing of the barrier element may be performed using different methods, externally by means of combined force-fitting together with stable strapping; or internally by joining together elements using glued through-plugs made of wood or other material; it is also possible to perform pre-tensioning (with a zero or higher pre-tensioning force) of the elements using bars (which may also be threaded) of different types and made of different material, or using other joining means pre-tensioned transversely with respect to the direction of the veining.

[0068] The advantage of the proposed structure is that the force which acts on the barrier element is much smaller than that which the cross-section of the wood would lead one to assume; the element is in fact able to deform internally, without causing significant differences in the external dimensions; consequently, in order to prevent gaps or the formation of constructional gaps, a much smaller force, and no longer the total force generated by shrinkage and swelling, has to be absorbed by means of the barrier element.

[0069] By assembling several panels having the characteristics described, if necessary with a smaller thickness, rotating them so that the veining (or the direction of the webs) is arranged perpendicularly with respect to the other layers, one of more of these panels may be used as a barrier layer, further barrier layers (Fig. 13) with a different configuration thus no longer being needed. It is also possible for the surfaces to have different characteristics and be able to withstand different external agents. It is thus possible, by means of a varying surface composition and structure, to obtain reactions which may adapt to the different forces involved.

[0070] In those cases where the elements are force-fitted together with other building/constructional components which may perform the blocking or barrier function,

barrier layers for the panels according to the invention may be dispensed with, in view of the minimum forces acting on them. This is the case for example of panels according to the invention which are installed as wall elements with the height of one storey and which are force-fitted along their whole width together with the floor slab and floor structure.

BOARDS

[0071] As shown in Figs. 19-27 it is envisaged that, where wooden materials or similarly machinable materials are used, it is possible to obtain the panels according to the invention from boards 418-422.

[0072] A plurality of boards 419-426, arranged opposite each other in a direction perpendicular to the longitudinal direction of extension of the veining, form the panels according to the present invention, wherein the boards constitute the longitudinal joining elements for forming the longitudinal members or directly the finished panels.

[0073] According to preferred embodiments of these boards, shown in Figs. 19-27, said boards comprise several base elements 10,110,210, or suitable cut designs thereof, which are joined together along the respective outer surfaces 11a,13a of the flanges 11,13. Figs. 19-27 also show the different machined designs obtained using cutting tools such as saws, milling cutters and the like in order to obtain the desired configurations of the boards and therefore the simple production of the panels according to the invention in the case of wood materials or similarly machinable materials.

[0074] Although not shown it is also envisaged that the joining together of several base elements 10,210,310 results in the formation of boards 419-426 which have alternating flanges 11,13 and recesses 12a,12b mutually staggered with respect to the direction perpendicular to that of the veining 1a and the opposite ends of which have a board finishing surface 201 with the function of providing static resistance to the loads, in particular perpendicular loads.

[0075] It will therefore be possible to obtain panels 1000 formed by the joining together of a plurality of boards joined together in one of the two directions which are perpendicular (transverse or vertical) relative to the veining direction so as to form panels 1000 which have rows of cavities 1021,1022, the extension of which in the transverse direction Y-Y is equal to the sum of a first and a second recess and which are staggered by half a unit with respect to the two adjacent rows, so as to form the longitudinal cavities having a cross-section which is in the form of an hour-glass, X-shaped or I-shaped.

[0076] In the case instead of materials which may be softened, it is envisaged that the panels may be made using different technologies such as extrusion along the longitudinal direction X-X and subsequent cutting and addition so as to form different sections which determine the various shapes of the panels and the associated lon-

gitudinal webs and recesses.

[0077] In this case it will also be possible to obtain boards from the design of a panel and by means of regular and/or irregular cutting of this design; the boards are thus still suitable for the formation of panels of varying shape.

[0078] It is also envisaged that multiple variants may be introduced during the practical implementation of the various component parts forming the subject of the present invention, e.g.:

-) the recesses in the wooden elements may be separated by means of interruptions along the veining of said element, in order to prevent undesirable internal circulation of the air; similarly improved static characteristics may be obtained in the support zone by means of interruptions along the edges. By means of a partial interruption of the cavities it is possible to improve in a specific manner the static characteristics of wooden board elements for roofs or floor structures.

-) the cavities in the panels may be filled entirely or partially with suitable insulating material or with the shavings resulting from the machining for forming the recesses, so as to allow an improvement in the heat insulation and fire behaviour properties;

-) barrier layer with direction of the veining arranged transversely or diagonally with respect to the veining of the boards may also be inserted between said boards for example after each third or after each tenth, preferably after each fifth to seventh board; this results not only in a greater precision in the required measurements, but also a substantially greater load-bearing capacity of the elements;

-) the panels may also be used as wall elements in which the boards of the self-supporting multi-layer panel are arranged horizontally; in this case the barrier layers are designed as vertical or diagonal load-bearing elements. These may be applied or inserted in the form of sheets with vertical or diagonal veining, battens or boards or other cut wood sections and force-fitted together with the panel itself. For the formation of load-bearing boards this layer may act as a ventilated-cavity surface and/or installation surface;

-) the design structure of base elements, longitudinal members, boards and panels according to the invention may also be applied to natural and synthetic materials with different characteristics in one or more sizes, i.e. which are for example anisotropic with respect to the static load, shrinkage and swelling behaviour, thermal behaviour or other physical characteristics which are typical of the building sector; the boards and panels may in this case be produced using folded or corrugated boards which may be joined together by means of webs which may be made of materials different from those of the boards. The production of board elements or profiled elements according to the invention in this case may

also be obtained using different materials obtained by means of the extrusion technique;

-) it is possible to achieve the characteristics of the elements, as described, for shrinkage and swelling of the wooden body without force-fitting together the single planks or the single boards using adhesives. In this case the elements must be compressed and consequently subjected to pre-tensioning in one of the directions transverse to the veining (implicitly causing, owing to the characteristic feature of the invention, pre-tensioning in the other direction transverse to the veining) so that, after application of the barrier layers, said layers are subject to pressure at all times and in all conditions; alternatively it is possible to reduce the moisture content of the wood of the elements by means of controlled drying so that the general conditions of the atmospheric agents, at any moment and in any condition, are defined by limited swelling compared to the assembly condition, with the result that the element is in turn subject to continuous compressive stressing;

-) the joining together of the single elements by means of interlocking pressure joints, for example a series of tongues and grooves or a tenon and mortise joint, together with the tendency of the elements to relax and the dimensions to expand in both directions relative to the direction transverse to the veining following keying together of the tongues or tenons, are such that the single elements are joined together as a single combined element by means of tensile and compressive force. The wooden constructional elements thus produced behave in accordance with the principle forming the basis of the invention without the need for glued joints resistant to tensile stress.

[0079] In addition the material machining methods are of a conventional nature and performed using sawing or milling tools.

[0080] It is therefore clear how the base elements, the longitudinal members and the panels according to the invention have heat insulation, structural strength, soundproofing and heat conductivity characteristics which are substantially better than those of solid elements.

[0081] In addition, the special I-shaped, X-shaped or hour-glass like form and the arrangement of the cavities aligned in one of the two directions perpendicular to the veining of the wood and staggered relative to each other in the other perpendicular direction, together with the use of a barrier element in one of the directions transverse to the direction of the wood veining, have the effect that the shrinkage and swelling of the wood are compensated for in both directions transverse to the direction of the wood veining, with the wood shrinkage and swelling forces being mainly absorbed by the single element, thus resulting in the barrier element having to absorb less force in order to keep the element in a stable form.

[0082] In the case of panels made of wooden materials

or the like preferred embodiments envisage providing cavities having a width smaller than 5 mm, preferably between 2 mm and 5 mm, flange and web thicknesses greater than about 4 cm, depending also on the type of wood, and solid-void ratios preferably of between 70%:30% and 50%:50%.

[0083] Although described in connection with a number of preferred embodiments it is understood that the scope of protection of the present invention is defined by the claims below.

Claims

1. Modular base element (10;210;310) made of material which is substantially anisotropic with regard to thermal behaviour and/or deformation due to shrinkage and swelling in a longitudinal direction (X-X) of the veining (1a),
having at least:

- a first flange (11) extending parallel to the longitudinal direction (X-X) of the veining and with a width extending in a first direction (Y-Y) perpendicular to the longitudinal direction (X-X), one surface (11a) thereof being flat;

- a second flange (13) extending parallel to the longitudinal direction (X-X) of the veining (1a) and with a width extending in a first direction (Y-Y) perpendicular to the longitudinal direction (X-X), one surface (13a) thereof being flat;

- a web (12;212;313) joining together one (11c,13c) of the two opposite end edges of the first flange (11) and the second flange (13);

wherein

- a first recess (12a;212a;312a) is formed between the web (12,212;312) and the first flange (11) and a second recess (12b;212b;312b) is formed between the web (12,212;312) and the second flange (13), both extending in the longitudinal direction (X-X) parallel to the veining (1a), defining an inclined theoretical web which joins together the two flanges and which has an inclination defined by a respective acute angle (α , β) (i.e. $< 90^\circ$) formed with the first flange and the second flange,

characterized in that

the first flange (11) and the second flange (13) have their respective free edges (11c,13c) projecting by a suitable amount, in the transverse direction (Y-Y) of width of the flange, perpendicular to the veining direction (X-X), beyond the corner connecting together the web (12) and the other flange (13,11), and in opposite sense to each other.

2. Base element according to Claim 1, **characterized in that** said first recess (12a) and second recess (12b) are formed in the transverse direction (Y-Y).
3. Base element according to Claim 2, **characterized in that** the first recess (21) has a depth in the transverse direction the same as the depth of the second recess (22).
4. Base element according to Claim 3, **characterized in that** the first recess (12a) has a depth in the transverse direction (Y-Y) different from the depth of the second recess (12b).
5. Element according to any one of the preceding claims, **characterized in that** the amplitude of the angle of inclination (α , β) of the theoretical web (12;212;312) with respect to the first flange (11) or the second flange (12) is between 15° and 75°, and is preferably between 40° and 60°.
6. Base element (10;210;310) according to any one of the preceding claims, **characterized in that** it has recesses with a shape such as to define an inclined bar form of the web and Z-shaped form of the base element viewed in cross-section.
7. Base element (10;210;310) according to any one of the preceding claims, **characterized in that** said amount (D) by which the free edges (11c,13c) of the two flanges (11,13) project in the transverse direction (Y-Y) of width of the flange, perpendicular to the direction of the veining (X-X), is the same for both free edges (11c,13c).
8. Base element (10;210;310) according to any one of the preceding claims, **characterized in that** it has:
- a first spoiler (311) connected to the first flange (11) at its free end (11c) and directed towards the second flange (13); the spoiler (311) has an outer surface (311a) parallel to the vertical direction (Z-Z) and inner surface (311b) inclined parallel to the first web (212);
 - a second spoiler (313) with a substantially triangular cross-section, having a base (313a) integral with the free edge of the second flange (13); the outer side (313a) of the spoiler (313) is parallel to the vertical direction (Z-Z) and the oblique side (313b) is substantially parallel to the web (212).
9. Longitudinal member (500a-500n) extending in a longitudinal direction (X-X) of the veining (1a), **characterized in that** it is formed by the joining together of base elements (10,210,310) according to any one of Claims 1 to 8, joined to form an internal cavity extending in the longitudinal direction (X-X) of the veining and containing four angles between flanges and theoretical webs such as to define theoretical webs converging towards the centre of the cavity.
10. Longitudinal member (500a-550n) according to Claim 9, **characterized in that** it comprises:
- a first pair of base elements (10;210;310), each according to any one of Claims 1 to 8, which are joined together in a mirror-image arrangement in a first direction orthogonal with respect to the longitudinal direction (X-X);
 - a second pair of base elements (10;210;310), each according to any one of Claims 1 to 8, joined together in the same first direction perpendicular to the longitudinal direction (X-X);
 - the two pairs of base elements (10;210;310) being joined together in the other direction perpendicular to the veining such as to form the longitudinal cavity with theoretical webs converging towards the centre of the cavity.
11. Longitudinal member (500a-500n) according to any one of the preceding claims, **characterized in that** the cross-section of the longitudinal cavity is approximately in the form of an hour-glass, X-shaped, I-shaped or irregular, such as to maintain a structure with inclined theoretical webs directed in all cases towards the inside and converging towards the centre of the said cavity.
12. Longitudinal member (500a-500n) according to any one of the preceding claims, **characterized in that** said base elements are joined together along the outer flat surface (11a,13a) and/or along the free edges (11c,13c) parallel to the vertical direction (Z-Z) of the respective base flanges (11,13).
13. Panel (1000) made of material which is substantially anisotropic with regard to thermal behaviour and/or deformation due to shrinkage and swelling in a longitudinal direction (X-X) of the veining (1a), **characterized in that** it comprises a plurality of internal cavities formed by the joining together of base elements (10,210,310) according to any one of Claims 1 to 8, extending in the longitudinal direction (X-X) of the veining and containing four acute angles (α ; β) between flanges (11,13,211,213,311,313) and theoretical webs, said angles (α ; β) being such as to define theoretical webs converging towards the centre of the cavity.
14. Panel (1000) according to the preceding claim, **characterized in that** said longitudinal cavities are aligned with each other in rows or columns along one of the two directions (Y-Y;Z-Z) perpendicular to the direction of the veining, each row or column of cavities being staggered with respect to the adjacent

row or column.

15. Panel (1000) according to the preceding claim, **characterized in that** said relative staggering of rows and columns in which the longitudinal cavities are aligned consists of a staggering equivalent to half a cavity. 5
16. Panel according to any one of the preceding claims, **characterized in that** said internal cavities (501a-501n) extending in the longitudinal direction (X-X) are defined by the joining together of the recesses (12a-12b;212a-212b;312a-312b) of different base elements (10,210,310) according to any one of Claims 1 to 7. 10
17. Panel according to the preceding claims, **characterized in that** the cross-section of the longitudinal cavities is such as to maintain a structure with inclined theoretical webs directed in all cases towards the inside and converging towards the centre of the said cavity. 20
18. Panel according to any one of the preceding claims, **characterized in that** the cross-section of the longitudinal cavities is approximately in the form of an hour-glass, X-shaped or I-shaped. 25
19. Panel according to any one of the preceding claims, **characterized in that** it has at least one barrier element which is anisotropic in one direction, said element being applied in one of the two directions perpendicular to the longitudinal direction (X-X) and so that said direction of anisotropy is perpendicular to the said longitudinal direction (X-X). 30
20. Panel according to the preceding claims, **characterized in that** it comprises at least two longitudinal members according to any one of Claims 9 to 13, arranged alongside each other in one of the two directions (Y-Y;Z-Z) perpendicular to the longitudinal direction (X-X). 40
21. Modular board (418-426) made of material substantially having a veining in a longitudinal direction (X-X) and anisotropic with regard to thermal behaviour and/or deformation due to shrinkage and swelling in the longitudinal direction (X-X) of the veining (1a), **characterized in that** it is formed by the regular or irregular cutting of the design of a panel according to any one of Claims 13 to 20. 45
22. Board according to Claim 21, **characterized in that** it comprises a plurality of base elements (10;210;310) according to any one of Claims 1 to 9 joined together in a direction perpendicular to said longitudinal direction (X-X) of the veining (1a). 50

23. Panel according to any one of Claims 13 to 20, **characterized in that** it is formed by means of the joining together of boards according to either one of Claims 21 and 22, joined in at least one of the two directions (Y-Y;Z-Z) perpendicular to the longitudinal direction (X-X). 5

Patentansprüche

1. Modulares Basisteil (10, 210, 310), das aus einem Material hergestellt ist, das bezüglich dem Temperaturverhalten und/oder der Verformung aufgrund von Schrumpfen oder Ausdehnen in einer Längsrichtung (X-X) der Maserung (1a) im Wesentlichen anisotrop ist, umfassend:

- einen ersten Flansch (11), der sich parallel zu der Längsrichtung (X-X) der Maserung erstreckt und eine Breite aufweist, die sich in eine erste Richtung (Y-Y) senkrecht zu der Längsrichtung (X-X) erstreckt, wobei eine Oberfläche (11a) davon flach ist;

- einen zweiten Flansch (13), der sich parallel zu der Längsrichtung (X-X) der Maserung (1a) erstreckt und eine Breite aufweist, die sich in eine erste Richtung (Y-Y) senkrecht zu der Längsrichtung (X-X) erstreckt, wobei eine Oberfläche (13a) davon flach ist;

- einen Steg (12, 212, 313), der eine (11c, 13c) der beiden gegenüberliegenden Endkanten des ersten Flansches (11) und des zweiten Flansches (13) miteinander verbindet;

wobei

- eine erste Aussparung (12a, 212a, 312a) zwischen dem Steg (12, 212, 312) und dem ersten Flansch (11) gebildet ist und eine zweite Aussparung (12b, 212b, 312b) zwischen dem Steg (12, 212, 312) und dem zweiten Flansch (13) gebildet ist, wobei sich beide Aussparungen in Längsrichtung (X-X) parallel zu der Maserung (1a) erstrecken und einen schrägen theoretischen Steg definieren, der die beiden Flansche miteinander verbindet und eine Neigung aufweist, die durch einen zugehörigen spitzen Winkel (α , β) (d.h. $< 90^\circ$) definiert ist, der mit dem ersten Flansch und dem zweiten Flansch gebildet ist,

dadurch gekennzeichnet, dass

die jeweilige freie Kante (11c, 13c) des ersten Flansches (11) und des zweiten Flansches (13) um einen geeigneten Betrag in Querrichtung (Y-Y) der Breite des Flansches, senkrecht zu der Maserrichtung (X-X), über die Ecke hervorsteht, die den Steg (12) mit dem anderen Flansch (13, 11), und umgekehrt, mit-

einander verbindet.

2. Basisteil gemäß Anspruch 1, **dadurch gekennzeichnet, dass** die erste Aussparung (12a) und die zweite Aussparung (12b) in Querrichtung (Y-Y) ausgebildet sind. 5
3. Basisteil gemäß Anspruch 2, **dadurch gekennzeichnet, dass** die erste Aussparung (12a) eine Tiefe in Querrichtung aufweist, die dieselbe ist wie die Tiefe der zweiten Aussparung (12b). 10
4. Basisteil gemäß Anspruch 3, **dadurch gekennzeichnet, dass** die erste Aussparung (12a) eine Tiefe in Querrichtung aufweist, die unterschiedlich zu der Tiefe der zweiten Aussparung (12b) ist. 15
5. Basisteil gemäß einem der vorstehenden Ansprüche, **dadurch gekennzeichnet, dass** die Größe des Neigungswinkels (α , β) des theoretischen Stegs (12, 212, 312) bezüglich des ersten Flansches (11) oder des zweiten Flansches (12) 15° bis 75° beträgt, vorzugsweise 40° bis 60° . 20
6. Basisteil (10, 210, 310) gemäß einem der vorstehenden Ansprüche, **dadurch gekennzeichnet, dass** es Aussparungen aufweist, die derart geformt sind, dass sie eine schräge Stangenform des Stegs und eine z-förmige Form des Basisteils in Querschnittsrichtung definieren. 25
30
7. Basisteil (10, 210, 310) gemäß einem der vorstehenden Ansprüche, **dadurch gekennzeichnet, dass** der Betrag (D), um welchen die freien Kanten (11c, 13c) der beiden Flansche (11, 13) in Querrichtung (Y-Y) der Breite des Flansches, senkrecht zu der Richtung der Maserung (X-X), vorstehen, für beide freien Kanten (11c, 13c) gleich ist. 35
8. Basisteil (10, 210, 310), gemäß einem der vorstehenden Ansprüche, **dadurch gekennzeichnet, dass** es umfasst: 40
 - einen ersten Spoiler (311), der mit dem ersten Flansch an dessen freien Ende (11c) verbunden ist und in Richtung des zweiten Flansches (13) ausgerichtet ist, wobei der Spoiler (311) eine Außenfläche (11a), die parallel zu der Vertikalrichtung (Z-Z) ist, und eine Innenfläche (313b) aufweist, die parallel zu dem ersten Steg (212) geneigt ist; 45
 - einen zweiten Spoiler (313) mit einer im Wesentlichen dreieckigen Querschnittsform, wobei der Spoiler eine Integral mit dem freien Ende des zweiten Flansches (13) ausgebildete Grundfläche aufweist, wobei die Außenseite (313a) des Spoilers (313) parallel zu der Vertikalrichtung (Z-Z) ist und die Schrägseite (313b) 50

im Wesentlichen parallel zu dem Steg (212) ist.

9. Längsteil (500a-500n), das sich in einer Längsrichtung (X-X) der Maserung (1a) erstreckt, **dadurch gekennzeichnet, dass** es durch das Verbinden von Basisteilen (10, 210, 310) gemäß einem der vorstehenden Ansprüche 1 bis 8 gebildet ist, die zum Bilden eines Innenhohlraums verbunden sind, der sich in Längsrichtung (X-X) der Maserung erstreckt und vier Winkel zwischen den Flanschen und den theoretischen Stegen aufweist, um theoretische Stege zu definieren, die in Richtung des Zentrums des Hohlraums konvergieren. 5
10. Längsteil (500a-500n) gemäß Anspruch 9, **dadurch gekennzeichnet, dass** es umfasst: 10
 - ein erstes Paar Basisteile (10, 210, 310), die jeweils nach einem der Ansprüche 1 bis 8 ausgebildet sind und in einer Spiegelbildanordnung in einer ersten Richtung senkrecht bezüglich der Längsrichtung (X-X) miteinander verbunden sind;
 - ein zweites Paar Basisteile (10, 210, 310), die jeweils nach einem der Ansprüche 1 bis 8 ausgebildet sind und miteinander in derselben ersten Richtung senkrecht zu der Längsrichtung (X-X) verbunden sind;
 - wobei die zwei Paare von Basisteilen (10, 210, 310) derart in der anderen Richtung senkrecht zu der Maserung miteinander verbunden sind, dass der Längshohlraum mit theoretischen Stegen ausgebildet ist, die in Richtung des Zentrums des Hohlraums konvergieren. 15
11. Längsteil (500a-500n) gemäß einem der vorstehenden Ansprüche, **dadurch gekennzeichnet, dass** der Querschnitt des Längshohlraums näherungsweise sanduhrförmig, x-förmig, i-förmig oder unregelmäßig ausgebildet ist, um eine Struktur mit schrägen theoretischen Stegen zu erhalten, die in jedem Fall nach innen gerichtet sind und in Richtung des Zentrums dieses Hohlraums konvergieren. 20
12. Längsteil (500a-500n) gemäß einem der vorstehenden Ansprüche, **dadurch gekennzeichnet, dass** die Basisteile entlang der äußeren flachen Oberfläche (11a, 13a) und/oder entlang den freien Kanten (11c, 13c) parallel zu der Vertikalrichtung (Z-Z) des jeweiligen Basisflansches (11, 13) miteinander verbunden sind. 25
30
13. Paneel (1000), das aus einem Material hergestellt ist, das bezüglich dem Temperaturverhalten und/oder der Verformung aufgrund von Schrumpfen oder Ausdehnen in einer Längsrichtung (X-X) der Maserung (1a) im Wesentlichen anisotrop ist, **dadurch gekennzeichnet, dass** es mehrere Innen- 35

- hohlräume umfasst, die durch das Verbinden von Basisteilen (10, 210, 310) gemäß einem der Ansprüche 1 bis 8 gebildet sind, die sich in Längsrichtung (X-X) der Maserung erstrecken und vier spitze Winkel (α , β) zwischen Flanschen (11, 13, 211, 213, 311, 313) und theoretischen Stegen aufweisen, wobei die Winkel (α , β) derart gewählt sind, dass sie theoretische Stege definieren, die in Richtung des Zentrums des Hohlraums konvergieren.
14. Paneel (1000) gemäß dem vorstehenden Anspruch, **dadurch gekennzeichnet, dass** die Längshohlräume in Reihen oder Spalten entlang einer der beiden Richtungen (Y-Y, Z-Z) senkrecht zu der Richtung der Maserung zueinander ausgerichtet sind, wobei jede Reihe oder Spalte von Hohlräumen bezüglich der benachbarten Reihe oder Spalte versetzt ist.
15. Paneel (1000) gemäß dem vorstehenden Anspruch, **dadurch gekennzeichnet, dass** das relative Versetzen von Reihen und Spalten, in denen die Längsspalte zueinander ausgerichtet sind, einen Versatz aufweist, der einer Hälfte eines Hohlraums entspricht.
16. Paneel (1000) gemäß einem der vorstehenden Ansprüche, **dadurch gekennzeichnet, dass** die Innenhohlräume (501a-501n), die sich in Längsrichtung (X-X) erstrecken, durch das Verbinden der Aussparungen (12a-12b, 212a-212b, 312a-312b) von verschiedenen Basisteilen (10, 210, 310) gemäß einem der Ansprüche 1 bis 7 definiert sind.
17. Paneel gemäß den vorstehenden Ansprüchen, **dadurch gekennzeichnet, dass** der Querschnitt der Längshohlräume derart ausgebildet ist, dass eine Struktur mit schrägen theoretischen Stegen entsteht, die in jedem Fall nach innen gerichtet sind und in Richtung des Zentrums dieses Hohlraums konvergieren.
18. Paneel gemäß einem der vorstehenden Ansprüche, **dadurch gekennzeichnet, dass** der Querschnitt der Längshohlräume näherungsweise sanduhrförmig, x-förmig oder i-förmig ist.
19. Paneel gemäß einem der vorstehenden Ansprüche, **dadurch gekennzeichnet, dass** es wenigstens ein Sperrteil aufweist, das in einer Richtung anisotrop ist, wobei dieses Sperrteil in einer der beiden Richtungen senkrecht zu der Längsrichtung (X-X) derart eingesetzt ist, dass diese Richtung der Anisotropie senkrecht zu der Längsrichtung (X-X) ist.
20. Paneel gemäß den vorstehenden Ansprüchen, **dadurch gekennzeichnet, dass** es wenigstens zwei Längsteile gemäß einem der Ansprüche 9 bis 13 aufweist, die längs aneinander in einer der beiden Richtungen (Y-Y, Z-Z) senkrecht zu der Längsrichtung (X-X) angeordnet sind.
21. Modulare Platte (418-426), die aus einem Material hergestellt ist, das im Wesentlichen eine Maserung in einer Längsrichtung (X-X) aufweist und bezüglich dem Temperaturverhalten und/oder der Deformation aufgrund von Schrumpfen oder Ausdehnen in der Längsrichtung (X-X) der Maserung (1a) anisotrop ist, **dadurch gekennzeichnet, dass** es durch das regelmäßige oder unregelmäßige Schneiden der Form eines Paneels gemäß einem der Ansprüche 13 bis 20 gebildet ist.
22. Platte gemäß Anspruch 21, **dadurch gekennzeichnet, dass** es mehrere Basisteile (10, 210, 310) gemäß einem der Ansprüche 1 bis 9 aufweist, die in einer Richtung senkrecht zu der Längsrichtung (X-X) der Maserung (1a) miteinander verbunden sind.
23. Paneel gemäß einem der Ansprüche 13 bis 20, **dadurch gekennzeichnet, dass** es mittels des Verbindens von Platten gemäß einem der Ansprüche 21 und 22 gebildet ist, die in wenigstens einer der beiden Richtungen (Y-Y, Z-Z) senkrecht zu der Längsrichtung (X-X) miteinander verbunden sind.

Revendications

1. Élément de base modulaire (10 ; 210 ; 310) fabriqué en matériau sensiblement anisotrope par rapport à un comportement et/ou une déformation thermiques dus à un retrait et à un gonflement dans une direction longitudinale (X-X) de la veine (1a), comportant au moins :
- un premier rebord (11) s'étendant parallèlement à la direction longitudinale (X-X) de la veine et ayant une largeur s'étendant dans une première direction (Y-Y) perpendiculaire à la direction longitudinale (X-X), sa surface (11a) étant plate ;
 - un second rebord (13) s'étendant parallèlement à la direction longitudinale (X-X) de la veine (1a) et ayant une largeur s'étendant dans une première direction (Y-Y) perpendiculaire à la direction longitudinale (X-X), sa surface (13a) étant plate ;
 - une bande (12 ; 212 ; 313) reliant l'un à l'autre l'un (11c, 13c) des deux bords d'extrémité opposés du premier rebord (11) et du second rebord (13) ;
- dans lequel
- un premier évidement (12a ; 212a ; 312a) est formé entre la bande (12 ; 212 ; 312) et le pre-

mier rebord (11), et un second évidement (12b ; 212b ; 312b) est formé entre la bande (12 ; 212 ; 312) et le second rebord (13), tous les deux s'étendant dans la direction longitudinale (X-X) parallèle à la veine (1a), définissant une bande théorique inclinée qui relie l'un à l'autre les deux rebords et dont une inclinaison est définie par un angle aigu respectif (α , β) (c'est-à-dire, $< 90^\circ$) formé avec le premier rebord et avec le second rebord,

caractérisé en ce que

les bords libres respectifs (11c, 13c) du premier rebord (11) et du second rebord (13) font saillie sur une étendue appropriée, dans la direction transversale (Y-Y) de largeur du rebord, perpendiculaire à la direction (X-X) de la veine, au-delà du coin reliant l'un à l'autre la bande (12) et l'autre rebord (13, 11), et dans des sens opposés l'un à l'autre.

2. Élément de base selon la revendication 1, **caractérisé en ce que** ledit premier évidement (12a) et ledit second évidement (12b) sont formés dans la direction transversale (Y-Y).
3. Élément de base selon la revendication 2, **caractérisé en ce que** le premier évidement (21) a une profondeur, dans la direction transversale, identique à la profondeur du second évidement (22).
4. Élément de base selon la revendication 3, **caractérisé en ce que** le premier évidement (12a) a une profondeur, dans la direction transversale (Y-Y) différente de la profondeur du second évidement (12b).
5. Élément selon l'une quelconque des revendications précédentes, **caractérisé en ce que** l'amplitude de l'angle d'inclinaison (α , β) de la bande théorique (12 ; 212 ; 312) par rapport au premier rebord (11) ou au second rebord (12) est comprise entre 15° et 75° et, de préférence, entre 40° et 60° .
6. Élément de base (10 ; 210 ; 310) selon l'une quelconque des revendications précédentes, **caractérisé en ce que** il comporte des évidements ayant une forme telle qu'ils définissent une forme de barre inclinée de la bande et une forme de Z lorsque l'on observe l'élément de base en coupe transversale.
7. Élément de base (10 ; 210 ; 310) selon l'une quelconque des revendications précédentes, **caractérisé en ce que** ladite étendue (D) de saillie des bords libres (11c, 13c) des deux rebords (11, 13) dans la direction transversale (Y-Y) de largeur du rebord, perpendiculaire à la direction de la veine (X-X), est la même pour les deux bords libres (11c, 13c).
8. Élément de base (10 ; 210 ; 310) selon l'une quel-

conque des revendications précédentes, **caractérisé en ce que** il comporte :

- un premier aileron (311) relié au premier rebord (11) au niveau de son extrémité libre (11c) et orienté vers le second rebord (13) ; l'aileron (311) comportant une surface extérieure (311a) parallèle à la direction verticale (Z-Z) et une surface intérieure (311b) inclinée parallèlement à la première bande (212) ;
 - un second aileron (313) de section transversale sensiblement triangulaire, comportant une base (313a) d'un seul tenant avec le bord libre du second rebord (13) ; le côté extérieur (313a) de l'aileron (313) étant parallèle à la direction verticale (Z-Z) et le côté oblique (313b) étant sensiblement parallèle à la bande (212).
9. Élément longitudinal (500a-500n) s'étendant dans une direction longitudinale (X-X) de la veine (1a), **caractérisé en ce que** il est formé par liaison, les uns aux autres, d'éléments de base (10, 210, 310) selon l'une quelconque des revendications 1 à 8, reliés pour former une cavité interne s'étendant dans la direction longitudinale (X-X) de la veine et comportant quatre angles entre des rebords et des bandes théoriques de façon à définir des bandes théoriques convergeant vers le centre de la cavité.
 10. Élément longitudinal (500a-550n) selon la revendication 9, **caractérisé en ce que** il comprend :
 - une première paire d'éléments de base (10 ; 210 ; 310), chaque élément de base étant un élément de base selon l'une quelconque des revendications 1 à 8, qui sont reliés l'un à l'autre selon un agencement d'image miroir dans une première direction orthogonale par rapport à la direction longitudinale (X-X) ;
 - une seconde paire d'éléments de base (10 ; 210 ; 310), chaque élément de base étant un élément de base selon l'une quelconque des revendications 1 à 8, reliés l'un à l'autre dans la même première direction perpendiculaire à la direction longitudinale (X-X) ;
 - les éléments de base des deux paires d'éléments de base (10 ; 210 ; 310) étant reliés les uns aux autres dans l'autre direction perpendiculaire à la veine de façon à former la cavité longitudinale avec des bandes théoriques convergeant vers le centre de la cavité.
 11. Élément longitudinal (500a-500n) selon l'une quelconque des revendications précédentes, **caractérisé en ce que** la section transversale de la cavité longitudinale a sensiblement la forme d'un sablier, ayant une forme de X, une forme de I ou une forme irrégulière, de façon à maintenir une structure avec

- des bandes théoriques inclinées orientées, dans tous les cas, vers l'intérieur et convergeant en direction du centre de ladite cavité.
12. Élément longitudinal (500a-500n) selon l'une quelconque des revendications précédentes, **caractérisé en ce que** lesdits éléments de base sont reliés les uns aux autres le long de la surface extérieure plate (11a, 13a) et/ou le long des bords libres (11c, 13c) parallèles à la direction verticale (Z-Z) des rebords (11, 13) de base respectifs. 5
13. Panneau (1000) fabriqué en matériau sensiblement anisotrope par rapport à un comportement et/ou une déformation thermiques dus à un retrait et à un gonflement dans une direction longitudinale (X-X) de la veine (1a), **caractérisé en ce qu'il** comprend une pluralité de cavités internes formées par liaison, les uns aux autres, d'éléments de base (10, 210, 310) selon l'une quelconque des revendications 1 à 8, s'étendant dans la direction longitudinale (X-X) de la veine et comprenant quatre angles aigus (α ; β) entre des rebords (11, 13, 211, 213, 311, 313) et des bandes théoriques, lesdits angles (α ; β) étant tels qu'ils définissent des bandes théoriques convergeant en direction du centre de la cavité. 10
14. Panneau (1000) selon la revendication précédente, **caractérisé en ce que** lesdites cavités longitudinales sont alignées les unes avec les autres en rangées ou en colonnes dans une des deux directions (Y-Y ; Z-Z) perpendiculaires à la direction de la veine, chaque rangée ou colonne de cavités étant disposée en quinconce par rapport à la rangée ou à la colonne adjacente. 20
15. Panneau (1000) selon la revendication précédente, **caractérisé en ce que** ladite disposition en quinconce relative de rangées et de colonnes selon laquelle les cavités longitudinales sont alignées consiste en une disposition en quinconce équivalant à une demie-cavité. 25
16. Panneau selon l'une quelconque des revendications précédentes, **caractérisé en ce que** lesdites cavités internes (501a-501n) s'étendant dans la direction longitudinale (X-X) sont définies par liaison, les uns aux autres, des évidements (12a-12b ; 212a-212b ; 312a-312b) d'éléments de base différents (10, 210, 310) selon l'une quelconque des revendications 1 à 7. 30
17. Panneau selon les revendications précédentes, **caractérisé en ce que** la section transversale des cavités longitudinales est telle qu'elle maintient une structure avec des bandes théoriques inclinées orientées, dans tous les cas, vers l'intérieur et convergeant en direction du centre de ladite cavité. 35
18. Panneau selon l'une quelconque des revendications précédentes, **caractérisé en ce que** la section transversale des cavités longitudinales a sensiblement la forme d'un sablier, la forme d'un X ou la forme d'un I. 40
19. Panneau selon l'une quelconque des revendications précédentes, **caractérisée en ce qu'il** comporte au moins un élément barrière anisotrope dans un sens, ledit élément étant appliqué dans l'une des deux directions perpendiculaires à la direction longitudinale (X-X) et **en ce que** ladite direction d'anisotropie est perpendiculaire à ladite direction longitudinale (X-X). 45
20. Panneau selon les revendications précédentes, **caractérisé en ce qu'il** comprend au moins deux éléments longitudinaux selon l'une quelconque des revendications 9 à 13, disposés l'un à côté de l'autre dans l'une des deux directions (Y-Y ; Z-Z) perpendiculaires à la direction longitudinale (X-X). 50
21. Planche modulaire (418-426) fabriquée en matériau comportant sensiblement une veine dans une direction longitudinale (X-X) et anisotrope par rapport à un comportement et/ou une déformation thermiques dus à un retrait et à un gonflement dans la direction longitudinale (X-X) de la veine (1a), **caractérisée en ce qu'elle** est formée par coupe régulière ou irrégulière de la conception d'un panneau selon l'une quelconque des revendications 13 à 20. 55
22. Planche selon la revendication 21, **caractérisée en ce qu'elle** comprend une pluralité d'éléments de base (10 ; 210 ; 310) selon l'une quelconque des revendications 1 à 9, reliés les uns aux autres dans une direction perpendiculaire à ladite direction longitudinale (X-X) de la veine (1a). 60
23. Panneau selon l'une quelconque des revendications 13 à 20, **caractérisé en ce qu'il** est formé par une liaison, les unes aux autres, de planches selon l'une ou l'autre des revendications 21 et 22, reliées dans au moins l'une des deux directions (Y-Y ; Z-Z) perpendiculaires à la direction longitudinale (X-X). 65

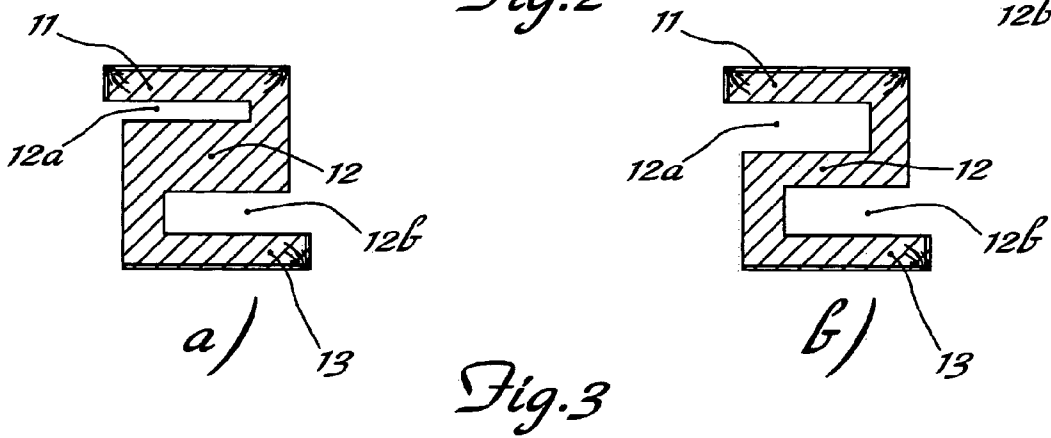
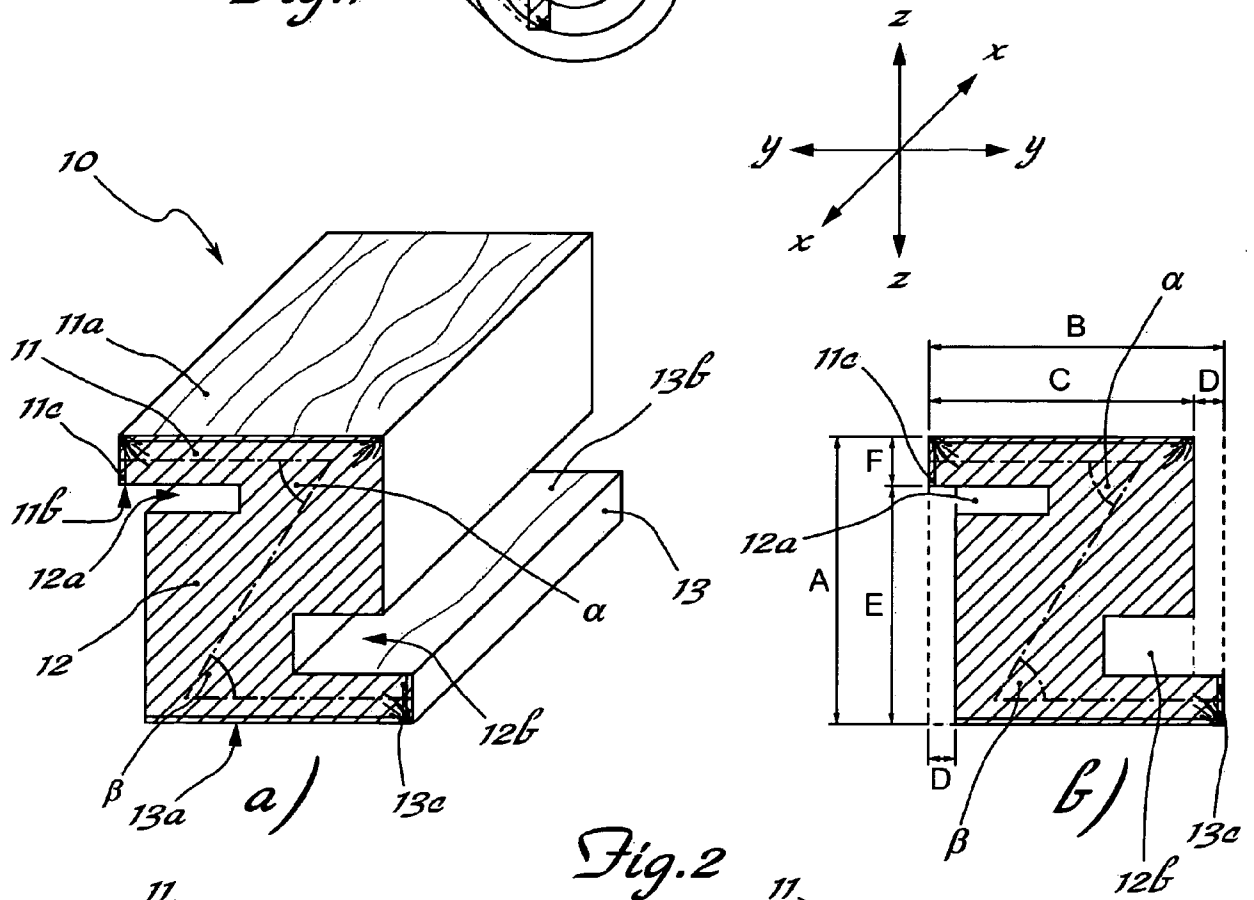
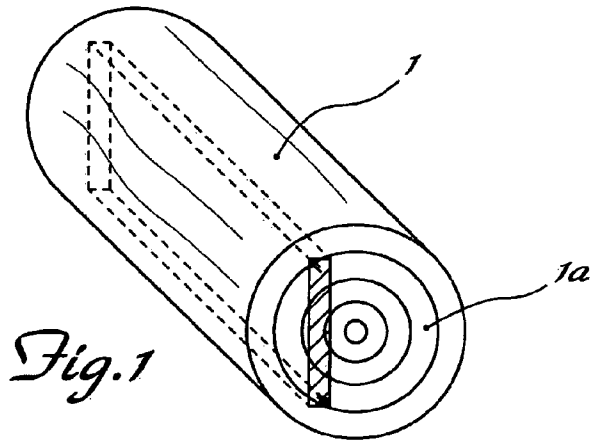

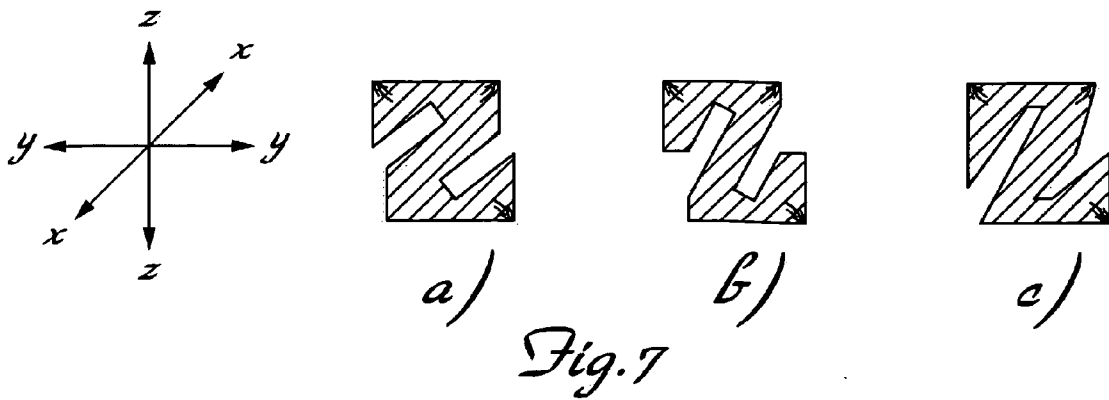
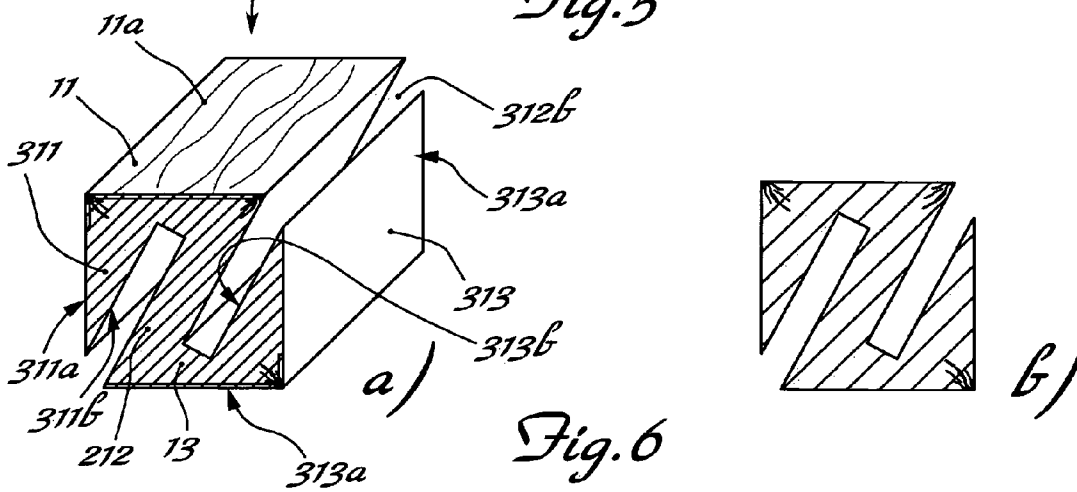
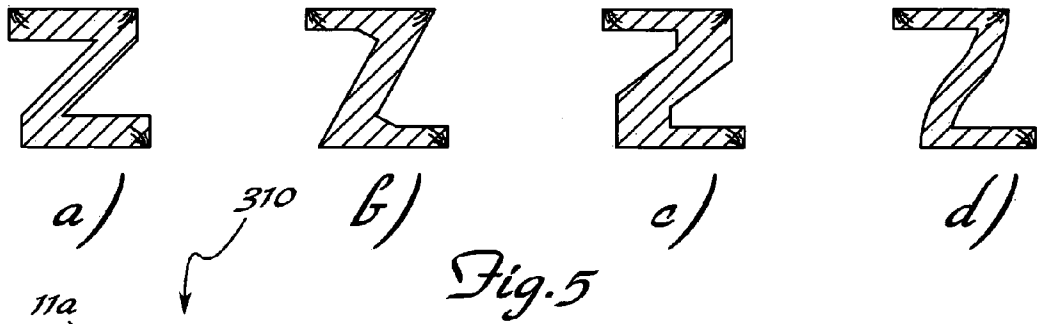
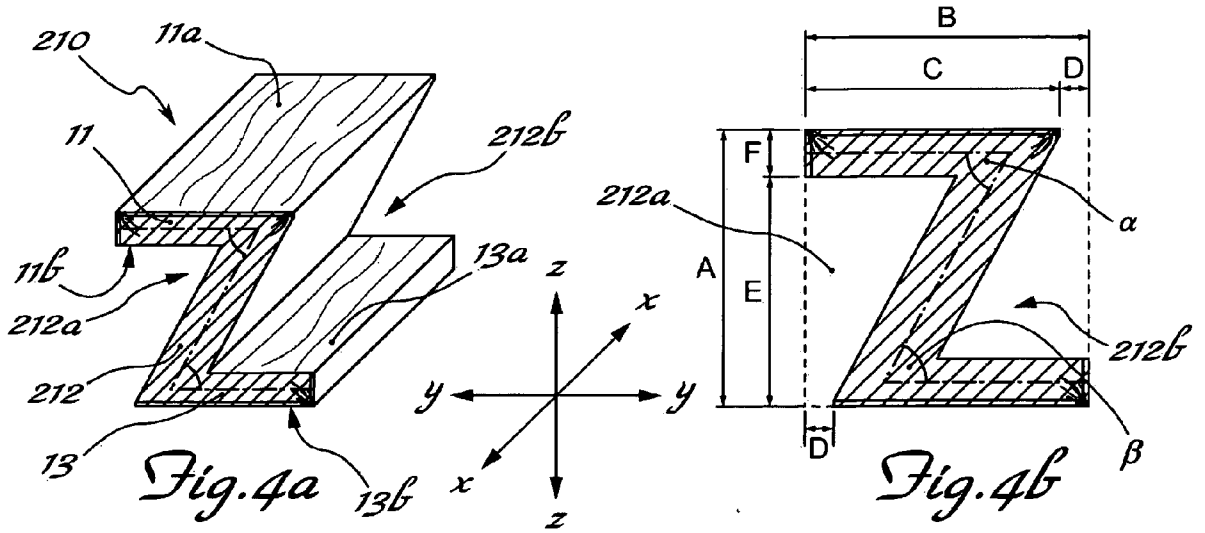

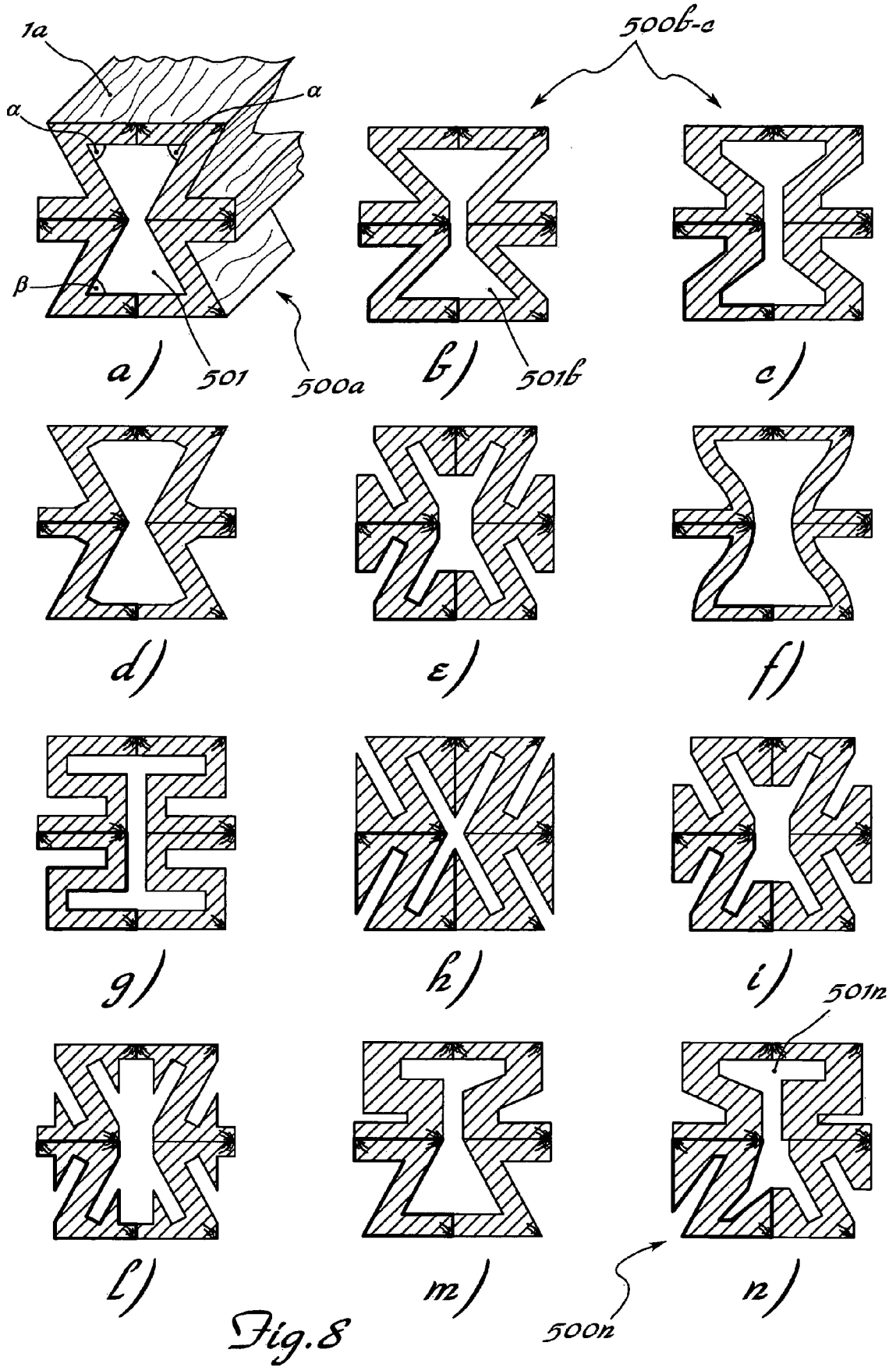

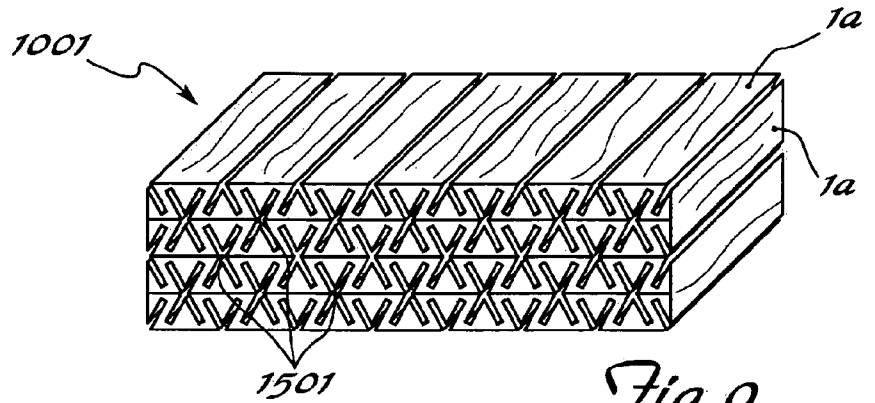

Fig. 9

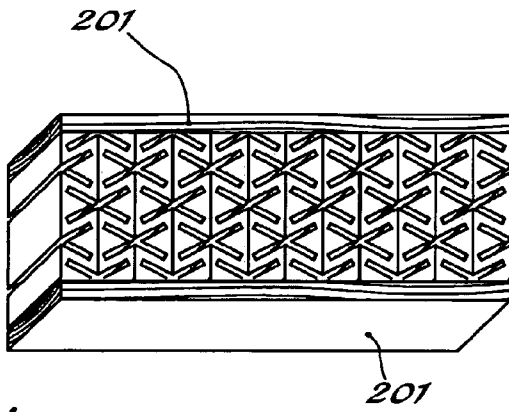

Fig. 10

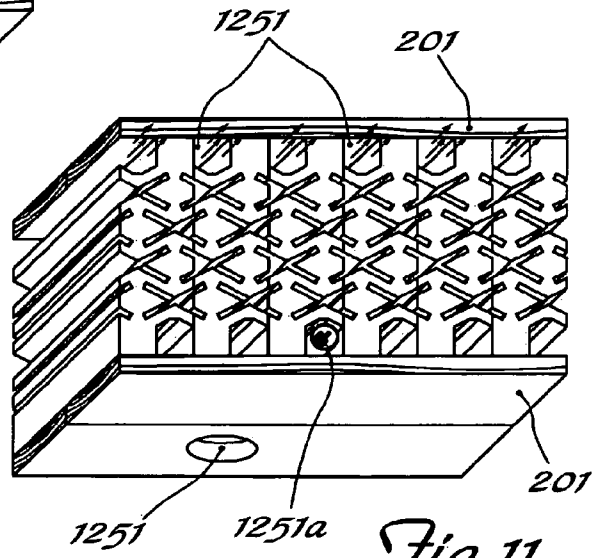

Fig. 11

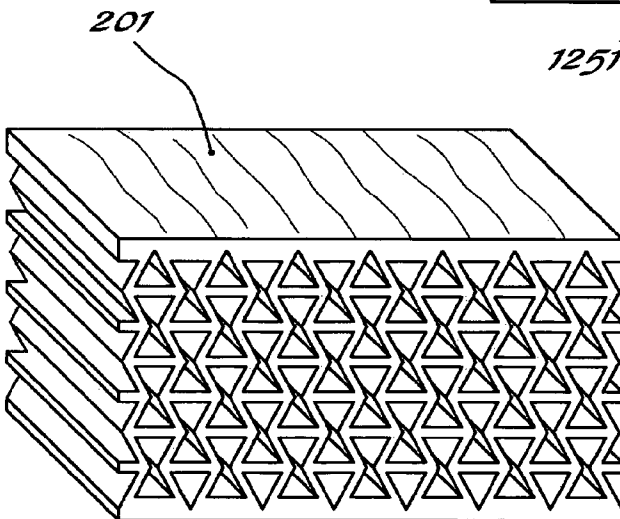

Fig. 12

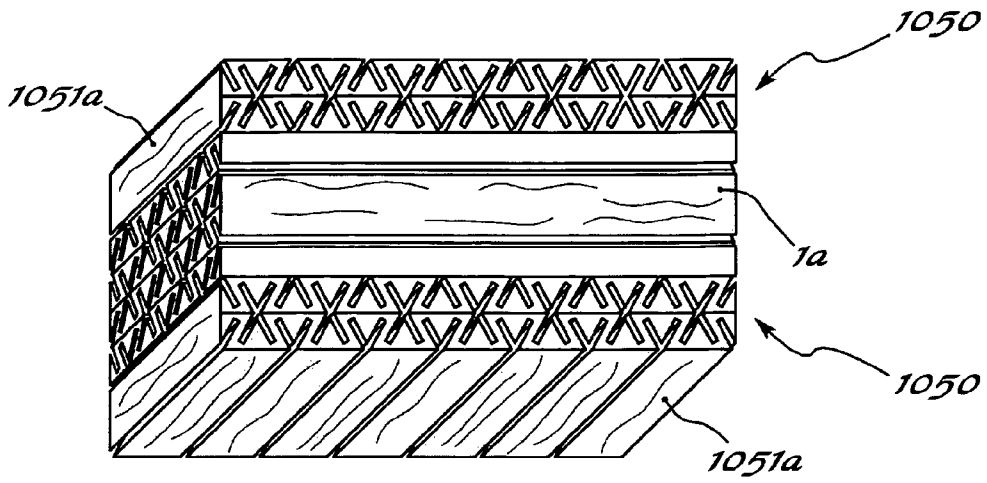

Fig. 13

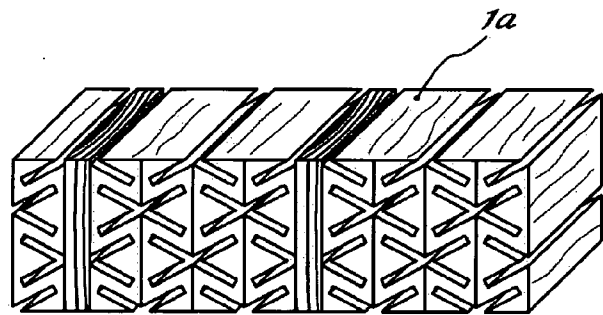

Fig. 14

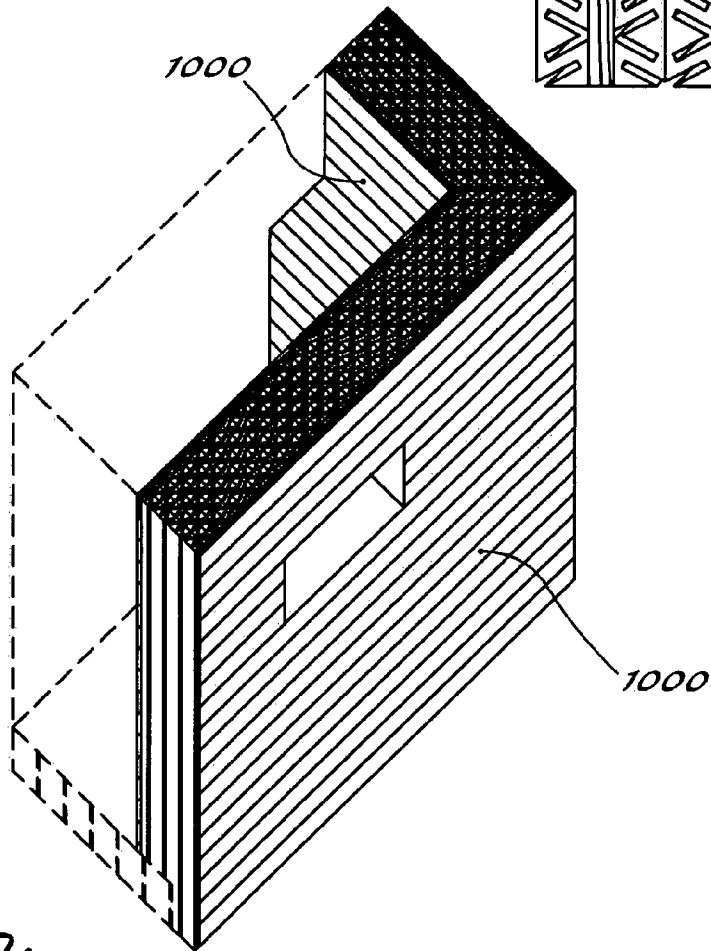

Fig. 15

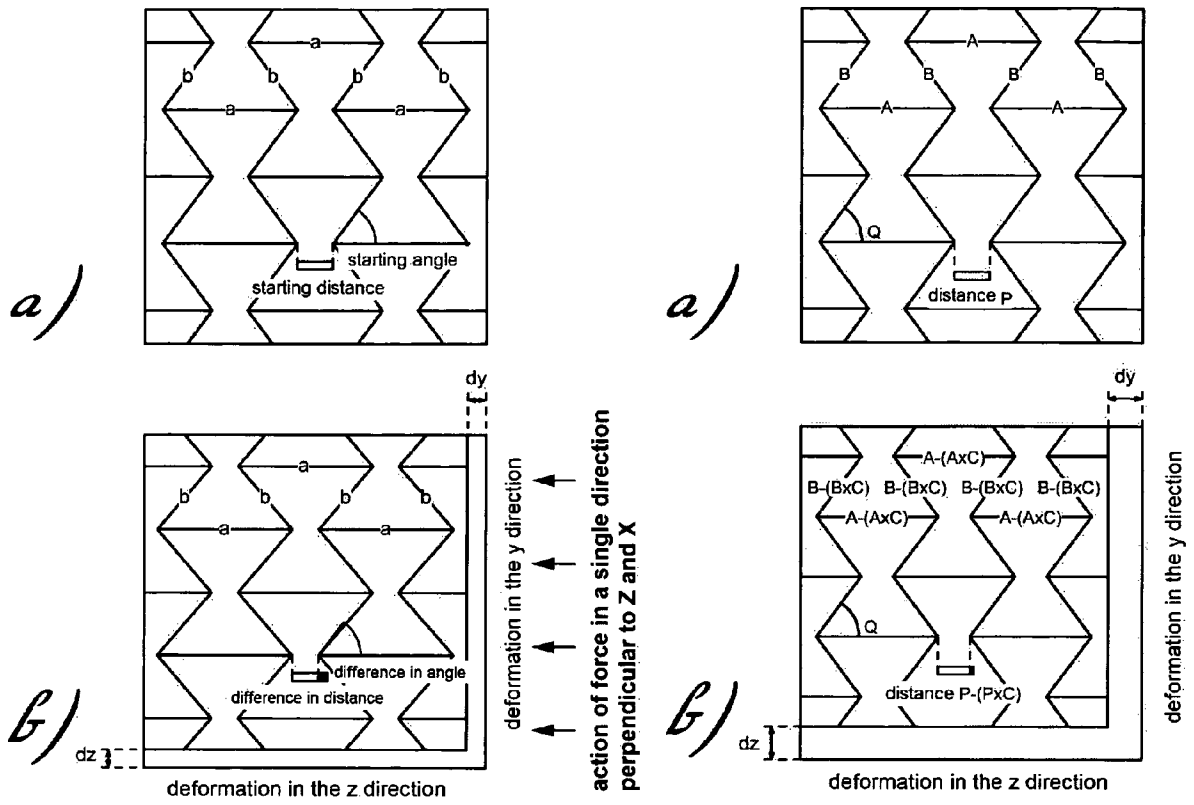

Fig. 16

Fig. 17

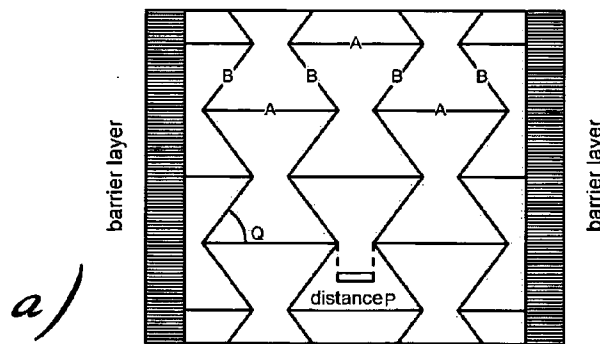
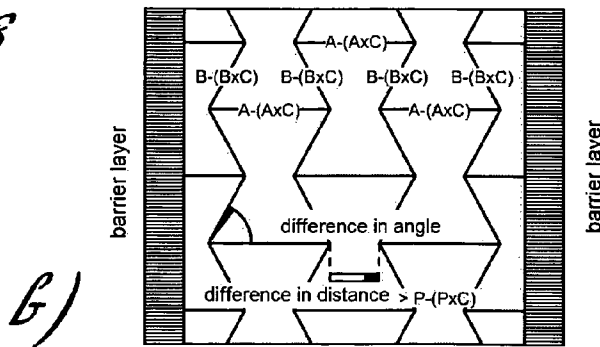

Fig. 18



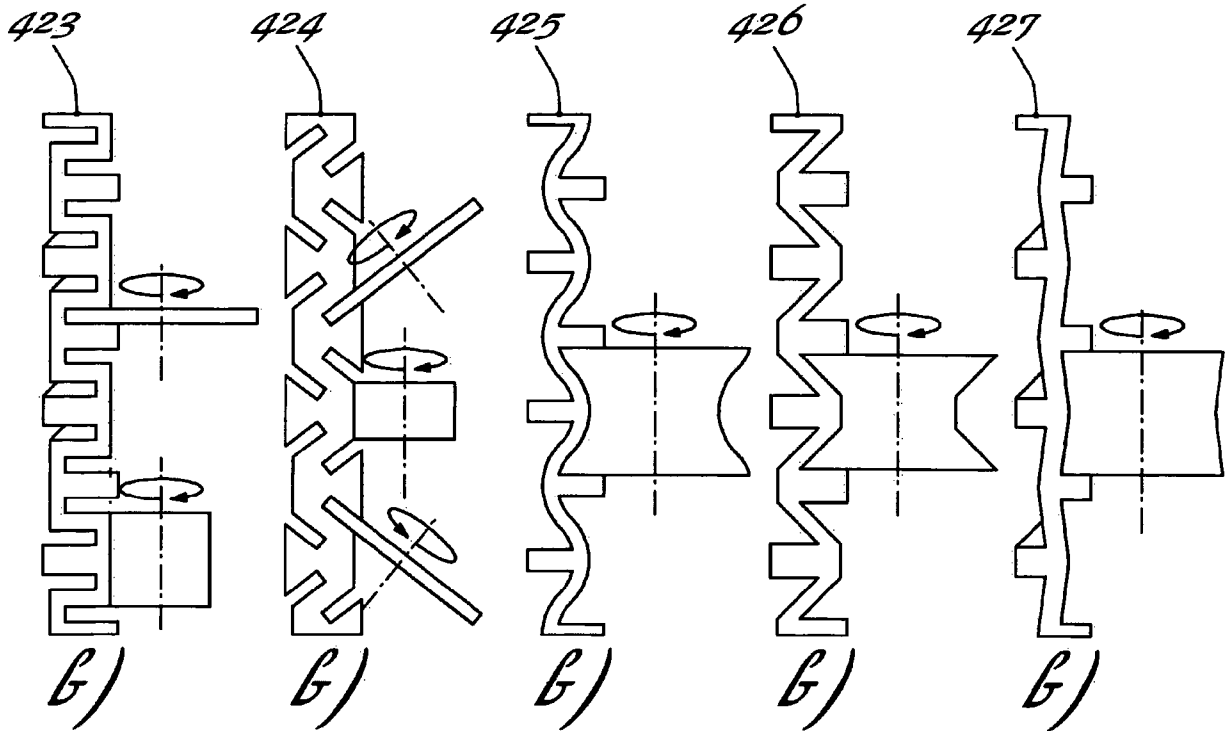
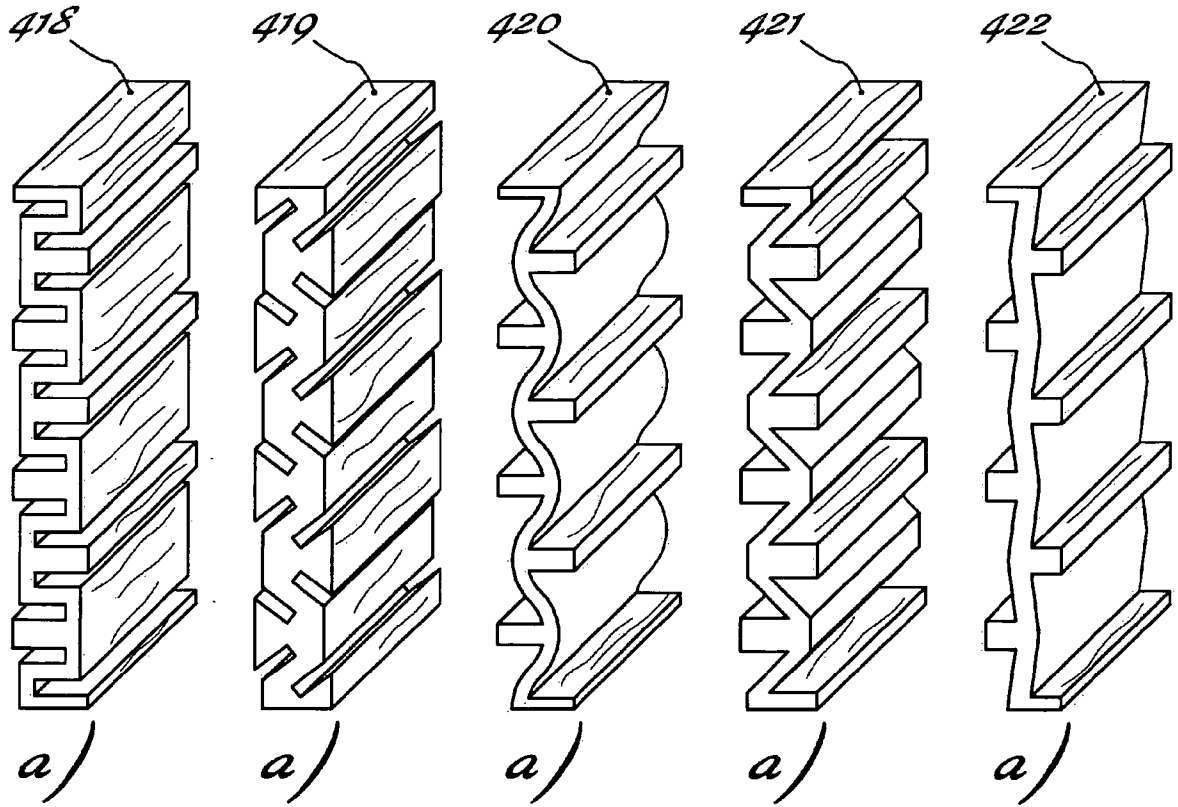

Fig.19 Fig.20 Fig.21 Fig.22 Fig.23

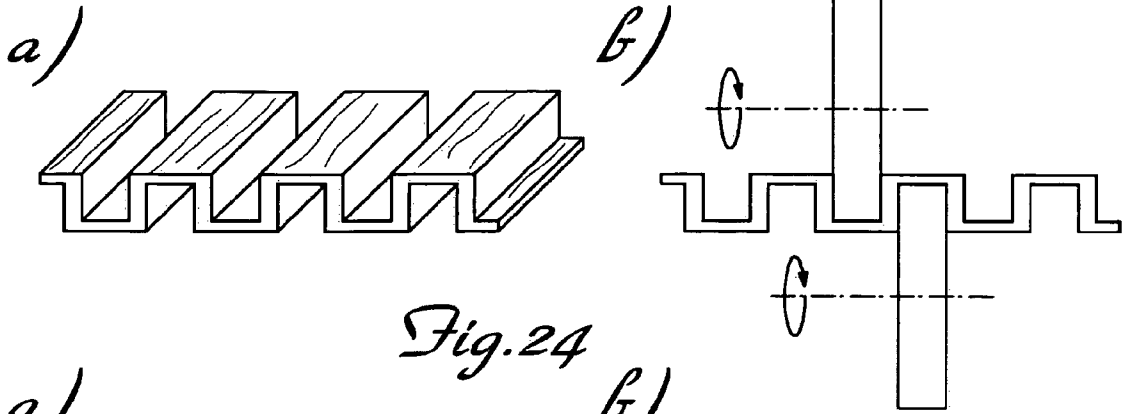

Fig.24

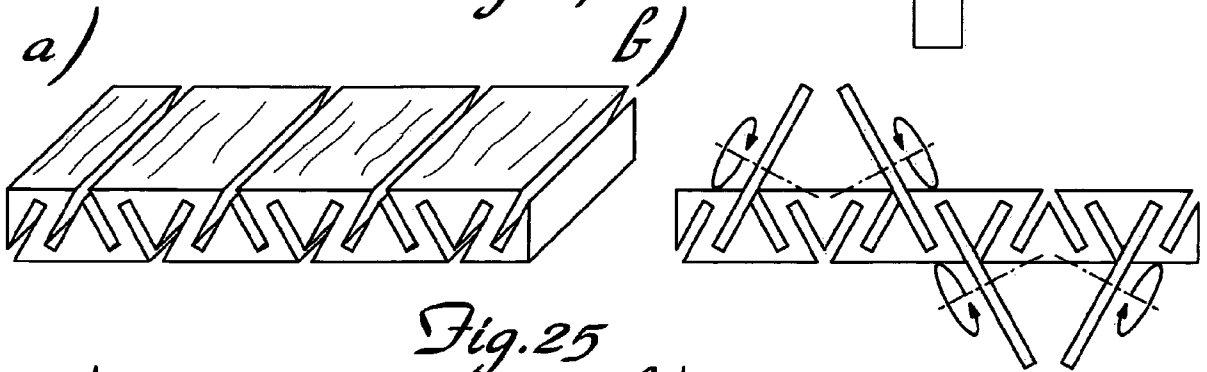

Fig.25

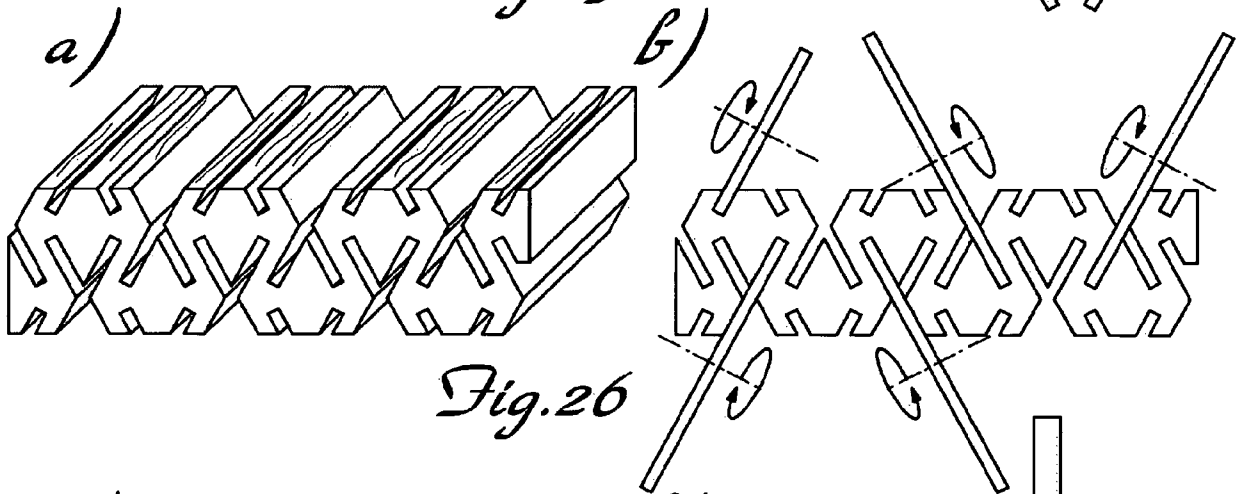

Fig.26

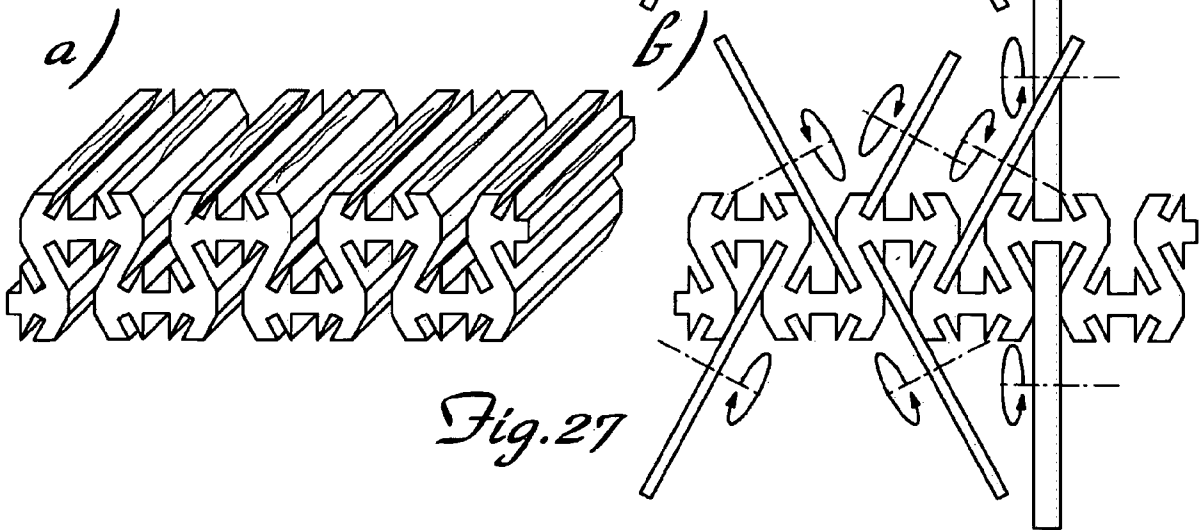

Fig.27

REFERENCES CITED IN THE DESCRIPTION

This list of references cited by the applicant is for the reader's convenience only. It does not form part of the European patent document. Even though great care has been taken in compiling the references, errors or omissions cannot be excluded and the EPO disclaims all liability in this regard.

Patent documents cited in the description

- EP 1734200 B1, Reinverbund [0016]
- DE 20208773 U1 [0017]
- EP 1288386 A1, Walch [0018]
- EP 1715114 A2 [0018]
- WO 2011000120 A [0019]
- WO 0077319 A1 [0020]

MODULRENDSZERŰ ALAPELEM, TOVÁBBÁ ILYEN ALAPELEMÉKBŐL

KIALAKÍTOTT HOSSZELEM, PANEL ÉS TÁBLA



SZTNH-100007711

SZABADALMI IGÉNYPONTOK

1. Modul rendszerű alapelem (10, 210; 310), amely a hőmozgás és/vagy a zsugorodás és duzzadás következtében az erezet (1a) hosszirányában (X-X) végbemenő alakváltozás tekintetében lényegében anizotrop anyagból van, és legalább a következőkkel van ellátva:

- első peremmel (11), amely párhuzamosan húzódik az erezet hosszirányával (X-X), és szélessége a hosszirányra (X-X) merőleges első irányú (Y-Y), és egyik felülete (11a) sík;
- második peremmel (13), amely párhuzamosan húzódik az erezet hosszirányával (X-X), és szélessége a hosszirányra (X-X) merőleges első irányú (Y-Y), és egyik felülete (13a) sík;
- gerinccel (12; 212; 313), amely összeköti az első perem (11) és a második perem (13) két, egymással átellenes peremek egyikét (11c, 13c);

és ahol

- első horony (12a; 212a; 312a) van kialakítva a gerinc (12; 212; 312) és az első perem (11) között, továbbá második horony (12b; 212b; 312b) van kialakítva a gerinc (12; 212; 312) és a második perem (13) között, ahol mindkettő hosszirányban (X-X), párhuzamosan húzódik az erezettel (1a), és a két peremet egymással összekötő ferde, elméleti gerincet határoz meg, és amely az első perem és a második perem által egymással bezárt hegyesszögben (α , β) (például $< 90^\circ$) dől,

azzal jellemezve, hogy

az első perem (11) és a második perem (13) szabad szélei (11c, 13c) a perem szélességére keresztirányban (Y-Y), az erezet irányára (X-X) merőlegesen, a gerincet (12) és a másik peremet (13, 11) egymáshoz csatlakoztató sarkon túlnyúlva, megfelelő mértékben kiállnak, és egymással ellentétes irányúak.

2. Az 1. igénypont szerinti alapelem, **azzal jellemezve**, hogy az első horony (12a) és a második horony (12b) keresztirányban (Y-Y) van kiképezve.

3. A 2. igénypont szerinti alapelem, **azzal jellemezve**, hogy az első horony (21) mélysége keresztirányban a második horony (22) mélységével azonos.

4. A 3. igénypont szerinti alapelem, **azzal jellemezve**, hogy az első horony (12a) mélysége keresztirányban (Y-Y) eltér a második horony (12b) mélységétől.

5. Az előző igénypontok bármelyike szerinti elem, **azzal jellemezve**, hogy az elméleti gerinc (12; 212; 312) dőlésszögének (α , β) nagysága az első peremhez (11) vagy a második peremhez (12) viszonyítva 15° és 75° között, célszerűen 40° és 60° között van.

6. Az előző igénypontok bármelyike szerinti alapelem (10; 210; 310), **azzal jellemezve**, hogy hornyainak alakja keresztmetszetben nézve ferde rúd alakú gerincet, és Z alakú alapelemet képez.

7. Az előző igénypontok bármelyike szerinti alapelem (10; 210; 310), **azzal jellemezve**, hogy az említett mérték (D), amellyel a két perem (11, 13) szabad peremei (11c, 13c), a perem szélességére keresztirányban (Y-Y), az erezet (X-X) irányára merőlegesen kinyúlnak, mindkét szabad szél (11c, 13c) esetében azonos.

8. Az előző igénypontok bármelyike szerinti alapelem (10; 210; 310), **azzal jellemezve**, hogy el van látva:

- első terelőelemmel (311), amely az első peremhez (11), annak szabad végén (11c) van csatlakoztatva, és a második perem (13) irányában áll; és a terelőelemnek (311) külső felülete (311a) van, amely párhuzamos a függőleges iránnyal (Z-Z), és belső felülete (311b) az első gerinccel (212) párhuzamosan dől;
- második terelőelem (313) van, amely lényegében háromszög keresztmetszetű, és alaprésze (313a) egyben van kialakítva a második perem (13) szabad szélével; és a terelőelem (313) külső oldala (313a) párhuzamos a függőleges iránnyal (Z-Z) és a ferde oldai (313b) lényegében párhuzamos a gerinccel (212).

9. Hosszelem (500a-500n), amely az erezet (1a) hosszirányában (X-X) húzódik, **azzal jellemezve**, hogy az 1. – 8. igénypontok bármelyike szerinti alapelemek (10; 210; 310) egymáshoz illesztésével van kialakítva, amelyek úgy vannak egymáshoz illesztve, hogy az erezet hosszirányában (X-X) húzódó belső üreget képeznek, és a peremek között négy sarka van, és az üreg központjának irányában összetartó elméleti gerincei vannak.

10. A 9. igénypont szerinti hosszilem (500a-500n), **azzal jellemezve**, hogy tartalmaz:

- első pár alapelemet (10; 210; 310), amelyek mindegyike az 1. – 8. igénypontok bármelyike szerinti, és amelyek egymáshoz tükröszerű elrendezésben vannak illesztve a hosszirányra (X-X) merőleges első irányban;
- második pár alapelemei (10; 210; 310) vannak, amelyek mindegyike az 1. – 8. igénypontok bármelyike szerinti, és amelyek a hosszirányra (X-X) merőleges ugyanazon első irányban vannak összeillesztve;
- a két pár alapelem (10; 210; 310) az erezettel párhuzamos második irányban van egymáshoz illesztve úgy, hogy hosszirányú üreget képeznek, amelyek elméleti gerincei az üreg középpontja felé összetartanak.

11. Az előző igénypontok bármelyike szerinti hosszilem (500a-500n), **azzal jellemezve**, hogy a hosszirányú üreg keresztmetszete megközelítőleg óraüveg alakú, X alakú, I alakú vagy szabálytalan úgy, hogy olyan szerkezetet képez, amelynek ferde elméleti gerincei minden esetben az üreg középpontja felé, a belső irányba tartanak össze.

12. Az előző igénypontok bármelyike szerinti hosszilem (500a-500n), **azzal jellemezve**, hogy az alapelemek a külső lapos felület (11a, 13a) mentén, és/vagy a megfelelő alapszélek (11, 13) függőleges irányával párhuzamos szabad végek (11c, 13c) mentén vannak egymáshoz csatlakoztatva.

13. Panel (1000), amely a hőmozgás és/vagy a zsugorodás és duzzadás következtében az erezet (1a) hosszirányában (X-X) végbemenő alakváltozás tekintetében lényegében anizotrop anyagból van, **azzal jellemezve**, hogy számos belső ürege van, amelyek az 1. – 8. igénypontok bármelyike szerinti alapelemek (10; 210; 310) egymáshoz csatlakoztatásával vannak kiképezve, és amely az erezet hosszirányában (X-X) húzódik, és négy hegyesszöget (α , β) tartalmaz peremek (11, 13, 211, 213, 311, 313) és elméleti gerincek között, ahol a szögek (α , β) az üreg középpontja felé összetartó elméleti gerinceket határoznak meg.

14. Az előző igénypontok bármelyike szerinti panel (1000), **azzal jellemezve**, hogy a hosszirányú üregek sorokban vagy oszlopokban egyvonalban vannak egymással az erezet irányára merőleges két irány (Y-Y; Z-Z) mentén, ahol az üregek minden sora vagy oszlopa lépcsőzetesen helyezkedik el a szomszédos sorhoz vagy oszlophoz képest.

15. Az előző igénypontok bármelyike szerinti panel (1000), **azzal jellemezve**, hogy a sorok és oszlopok egymáshoz viszonyított lépcsőzetes elrendezése, amelyben a hosszirányú üregek vannak egymással egyvonalban olyan, hogy a lépcsőzetesség mértéke az üreg felével egyenlő.

16. Az előző igénypontok bármelyike szerinti panel, **azzal jellemezve**, hogy a belső üregek (501a-501n), amelyek a hosszirányban (X-X) húzódnak az 1. – 7. igénypontok bármelyike szerinti különböző alapelemek (10, 210, 310) homyainak (12a-12b; 212a-212b; 312a-312b) egymáshoz történő csatlakoztatása révén vannak kialakítva.

17. Az előző igénypontok bármelyike szerinti panel, **azzal jellemezve**, hogy a hosszirányú üregek olyan szerkezetet képeznek, amely minden esetben befelé, és az üreg középpontja irányában összetartó, ferde elméleti gerincekből áll.

18. Az előző igénypontok bármelyike szerinti panel, **azzal jellemezve**, hogy a hosszirányú üregek keresztmetszete megközelítőleg óraüveg alakú, X-alakú vagy I-alakú.

19. Az előző igénypontok bármelyike szerinti panel, **azzal jellemezve**, hogy legalább egy zárórétege van, amely egy irányban anizotrop, és az említett elem a hosszirányra merőleges irányok (X-X) egyikében van elrendezve úgy, hogy az anizotrópia iránya merőleges a hosszirányra (X-X).

20. Az előző igénypontok bármelyike szerinti panel, **azzal jellemezve**, hogy legalább két, a 9. – 13. igénypontok bármelyike szerinti hosszirelemmel van ellátva, amelyek egymás mellett, a hosszirányra (X-X) merőleges két irány (Y-Y; Z-Z) egyikében vannak elrendezve.

21. Modul rendszerű tábla (418-426), amely a hőmozgás és/vagy a zsugorodás és duzzadás következtében az erezet (1a) hosszirányában (X-X) végbemenő alakváltozás tekintetében lényegében anizotrop anyagból van, **azzal jellemezve**, hogy a 13. – 20. igénypontok bármelyike szerinti panel szabálytalan vagy szabályos darabolásával van kialakítva.

22. A 21. igénypont szerinti tábla, **azzal jellemezve**, hogy számos, az 1. – 9. igénypontok bármelyike szerinti alapelemet (10, 210; 310) tartalmaz, amelyek az erezet (1a) hosszirányára (X-X) merőleges irányban vannak egymáshoz illesztve.

23. A 13. – 20. igénypontok bármelyike szerinti panel, **azzal jellemezve**, hogy a 21. és 22. igénypontok bármelyike szerinti táblák legalább a hosszirányra (X-X) merőleges két irány (Y-Y; Z-Z) közül az egyik irányban vannak egymáshoz illesztve.