

**EUROPEAN PATENT APPLICATION**

Application number: **84112251.8**

Int. Cl. 4: **B 01 L 3/02**

Date of filing: **11.10.84**

Priority: **13.10.83 US 541678**

Applicant: **CETUS CORPORATION, 1400 Fifty-Third Street, Emeryville California 94608 (US)**

Date of publication of application: **17.07.85**  
Bulletin 85/29

Inventor: **Williams, Fred Gardner, 516 Scenic Avenue, San Anselmo California 94960 (US)**

Designated Contracting States: **AT BE CH DE FR GB IT LI NL SE**

Representative: **Vossius Vossius Tauchner Heunemann Rauh, Siebertstrasse 4 P.O. Box 86 07 67, D-8000 München 86 (DE)**

**Disposable pipette tip.**

A disposable pipette tip (10) is formed for automatic installation and removal with low friction between the tip and pipette body (16) and a predetermined distance from the pipette body end (19) and the tip intake/discharge opening (12). The tip has a conical section (11) whose small end defines the tip intake/discharge opening and a cylindrical collar (14) that receives the pipette body. The tip is formed with an internal pipette seat (17) at the junction of the conical section and cylindrical collar so that the distance between the tip inlet/discharge opening and the pipette body end is fixed. The cylindrical collar also has a circumferential sealing rib (30) axially spaced from the pipette seat to form an air seal to account for manufacturing tolerances in the tip's cylindrical portion as to both diameter and roundness while maintaining low friction for installation and removal.

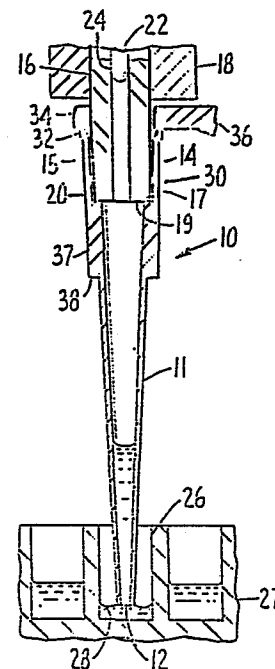

**EP 0 148 333 A1**

Our Ref.: T 359 EP  
Case: 2119  
Cetus Corporation  
California 94608, USA  
Priority: USA, Oct. 13, 1983, No.541,678

October 14, 1984  
0148333

DISPOSABLE PIPETTE TIP

Technical Field

The present invention relates to disposable  
5 tips for a pipette to take up and discharge accurately  
minute liquid quantities at any given level.

More specifically, it relates to a pipette tip  
that may be automatically picked up by and ejected from  
a reciprocable pipette. Such tip is preferably formed  
10 of a nonwetting plastic with a conical take up tip  
portion terminating at its base end in a generally  
cylindrical portion to mate with the pipette barrel.  
The cylindrical portion has (1) a stop, preferably a  
shoulder at its junction with the conical tip, that  
15 defines a seat for the end of the pipette barrel and  
establishes a known and repeatable distance from the end  
of the pipette barrel to the intake and discharge level  
of the tip and (2) an integral, internal circumferential  
seal between the stop and the open end of the cylinder  
20 to impose a low friction, air-tight seal around the  
pipette barrel.

Background Art

Pipettes to handle precise small amounts of  
liquid are known in the chemical, biological and  
25 biochemical fields. They are particularly useful for  
dispensing and transferring microliter quantities of  
culture media, diluents, and other liquids from one  
location to another.

In general such pipettes include a syringe with a reciprocable pump plunger operating in a barrel to aspirate liquid from or expel liquid into test tubes or wells in a microtiter tray through a replaceable tip.

5 Such pipettes have generally been used either single or as a "ganged" group for hand manipulation.

An automatic liquid transfer system that employs pipettes has recently been developed by applicant. The system is particularly directed to pick  
10 up and dispose of a replaceable tip after each liquid transfer to avoid cross-contamination or liquid carryover from one liquid volume, or sample, to another. Because the entire system is adapted to sequence automatically through a number of steps, each  
15 of which requires (1) an air-tight connection between the tip and the pipette nose or barrel, with a predeterminable friction for easy installation and removal and (2) a given, fixed distance from the inlet end of the tip to the end of the pipette barrel.

20 It has been known heretofore to form pipette tips of a generally conical form for replacement after each use to avoid contamination of liquids either during uptake or discharge with other liquids. For example to fill or dilute microbiological samples, it is frequently  
25 desirable to use one tip for a single use to pick up and dispense liquid. Various forms of friction and locking fits between the pipette barrel and disposable tips have been proposed by prior workers. However, such connections have been primarily suitable for assuring a  
30 fluid-tight fit between the barrel and tip and to resist accidental displacement of the tip by fluid pressure exerted by the pump mechanism of the pipette. Further,

such connections have not required a predetermined distance between the end of the pipette barrel and the intake-discharge end of the tip. Because such pipettes and tips are primarily for hand control or operation, 5 either single or as a group, the total friction between the tip and barrel is not important. Further, such friction fit is readily obtained by use of a conical nose on the pipette barrel having substantially the same taper as the inner surface of the tip. However, even 10 slight variations in diameters of the male and female tapers greatly affect overall length of the assembly. For example, with a 5° (included angle) taper, an angular error in fit results in an approximate 11.4-fold length error. Additionally, as noted above, the 15 assembled length will vary in accordance with insertion force. Accordingly, automatic insertion can result in significant length errors with such a sealing arrangement. Because such tips are normally molded from plastic materials, minor variations in the taper and 20 internal dimensions are to be expected.

The force to remove the tip from the pipette barrel also varies substantially with conical seals. Although an air tight seal is essential to proper aspiration through the tip for automatic installation 25 and removal, such friction must also be low and substantially reproducible for each replacement.

#### Statement of the Invention

The invention is a disposable pipette tip comprising an elongated conical tube, the small end of 30 which defines a passageway for liquid and the large end of which receives the end of a pipette, characterized in

that the tip includes a generally cylindrical collar for receiving the end of the pipette, the collar being axially aligned with and opening into the large end of the conical tube and having a stop for engaging the  
5 pipette to fix an accurately controlled distance from the end of the pipette to the small end of the pipette tip and a circumferential seal for forming a friction fit and seal with the sidewall of the pipette.

As indicated, the stop of the collar provides a  
10 seat for the end of the pipette to provide a fixed and known length for the overall assembly. In this way, capillary distances, on the order of several hundredths of a centimeter, between the inlet end of the tip and the liquid surface can be machine controlled when the  
15 tip is withdrawn. Further the inlet end of the tip may be accurately positioned at any other desired or given level in a microtiter plate well, such as at an oil-water interface. The circumferential seal between the lumen of the collar and the pipette barrel assures  
20 minimum friction with assured air sealing for tips within reasonable manufacturing tolerances. The circumferential rib seal also assures easy removal of the tip for disposal after a single use, particularly where a number of pipettes are ganged together and a  
25 single stripper simultaneously ejects the tips from their respective pipettes.

#### Brief Description of the Drawings

Figure 1 is a side elevation view of an  
embodiment of the disposable pipette tip, formed in  
30 accordance with the present invention, supported on the

external splines in a portion of a tip supply magazine having pigeon holes therein.

Figure 2 is a cross-sectional elevation view of the tip of Figure 1 seated on the end of a pipette barrel or nose, with the intake and discharge end of the tip shown in a microtiter tray well.

Figure 3 is an enlarged cross-sectional elevation view of the upper end of the tip of Figures 1 and 2 showing the construction of the pipette nose seating ledge or shoulder, the V-shaped air-sealing rib of the collar, and the external support splines.

Figure 4 is a plan view of the tip of Figures 1 and 2 taken toward the intake and discharge end.

Figure 5 is a cross-sectional view of a portion of a collar wall of the tip of Figures 1 and 2 showing a preferred embodiment of an integral circumferential sealing rib formed in the molding process.

Figure 6 is a cross-sectional view of a portion of the pipette nose and the collar portion of the tip showing an alternate sealing and nose-seating ledge arrangement.

#### Modes for Carrying Out the Invention

As shown in Figure 1, disposable pipette tip 10 includes an elongated, hollow conical tube section 11 terminating at its intake and discharge end 12 at a right angle to the axis of conical section 11. Base end 13 of conical tube 11 merges into a cylindrical mounting collar 14. As best seen in Figure 2, collar 14 provides a mounting and sealing arrangement with nose 15 of pipette barrel 16 carried by mounting block 18. As indicated a pump plunger 22 is arranged to reciprocate

in bore 24 of pipette barrel 16 to aspirate or discharge liquid through end 12 of tip 10.

In accordance with the present invention, lower end 19 of nose 15 seats on ledge or collar 17 formed by  
5 the transition between conical section 11 and  
cylindrical bore 20 of collar 14. Such seating of end 19 on ledge 17 fixes a precise distance from block 18 to tip intake-discharge port 12. It will be appreciated that radial projections other than a ledge or collar may  
10 be used to provide an axial stop for the end of the pipette barrel and that the projection need not be positioned at the transition between the conical and cylindrical section. In this regard the stop may be defined by a rim at the mouth of the cylindrical section  
15 that is adapted to engage a radial collar or other radial member on the exterior of the pipette. As indicated by the position of port 12 in well 26 of microtiter tray 27, the volume of liquid in such wells is frequently in microliters. Accordingly, capillary  
20 forces between liquid in or on tip 11, particularly near port 12 and well 26 are critical to proper control of the volume to be transferred. For this reason seating of nose end 19 on collar 17 permits control of the length of the capillary such as that indicated at 28 so  
25 that its length is both known and predeterminable for proper automatic operation of the pipette. Additionally, in cell cultures, it is frequently desirable to be able to draw or dispense liquid to a precise level in a microtiter well. For example, if a  
30 cell culture is in water below an oil layer it is important to be able to transfer the aqueous phase without disturbing the oil phase, or vice-versa.

Further, in accordance with the present invention bore 20 of collar 14 includes an integral circumferential rib or ring 30. As seen in Figure 3 and shown in enlarged view in Figure 5 rib 30 preferably has an axially deformed V-shape in cross section. Such construction permits a low friction fit between the sidewalls of nose 15 and bore 20 of tip 10 both for insertion and removal while accomodating large manufacturing tolerance (several thousandths of a centimeter) in diameter and roundness of bore 20. Such tolerances are particularly vital in molding of tips 10 preferably formed of thermoplastic or thermosetting materials, such as polypropylene, polyvinylchloride, and fluorocarbon polymers. At the same time an air-tight seal between the tip and pipette is assured to permit aspiration of liquid through inlet port 12, without leakage around the end 19 of nose 15 or reliance upon an air seal between the face of collar 17 and end 19. As an alternative to rib 30, the internal sidewall of the collar may have a slow taper that does not interfere with the action of the stop but causes the pipette to form a seal with the collar sidewall.

To permit tip 10 to be easily installed and stripped from nose 15, upper or open end 32 preferably has a bell-shaped mouth that terminates in a reinforced upper rim portion 34. The bell mouth permits easy access for the end 19 of nose 15 so that if the tip is not in the center of hole 31, as in Figure 1, the cylindrical portions of nose 15 and bore 20 will readily align with each other. Further rim portion 34 provides a pressing surface radially displaced from pipette nose

15 which is readily engageable by a stripper member 34 on an automatic stripper arm 36.

Replaceable tips in accordance with the present invention, in a preferred form, also include a plurality  
5 of three or more, preferably four, mounting splines 37, formed integral with the upper portion of conical section 11. Splines 37 also provide thrust absorbing means so that the force of barrel 16 entering the collar and seating on ledge 17 does not place deforming  
10 stresses on intake-discharge end 12 of the tip. As indicated, splines 37 desirably extend axially along the exterior of the section 11 from transition ring 39, just below collar or ledge 17, and each terminates in the upper quarter or less of the conical section to form  
15 support legs to hold the tip, as shown. Preferably, spline ends 38 are at substantially right angles to the axis of the tip to hold the tip in such a vertical position when seated over hole 31 formed in a plate, tube or box support, such as 40, having a flat top. As  
20 indicated, hole 31 in box 40 is slightly larger than the greatest diameter of conical section 11 at the level of spline ends 38, but small enough to prevent wedging of splines 36 in hole 31. It will also be noted that in this way splines 37 also provide minimum friction areas  
25 for absorbing thrust by ring 39 or cylindrical portion 14. Desirably the length of splines 37 is such that their bottoms 38 are just above the axial center of gravity of tip 10 so that the tip does not wobble excessively in response to horizontal accelerations.  
30 Such horizontal accelerations are important in high speed automatic liquid transfers and replacement of the tips on pipetter nose 15. This is because excess wobble

of the tip when it is being loaded onto nose 15 would require a pause sufficient to assure alignment.

As will be apparent to those skilled in the art and particularly those skilled in molding of plastic materials, such as polypropylene, the cylindrical portions such as bore 20 and splines 37 will be formed with a draft angle of less than  $2^\circ$  relative to the axis. Similarly, nose portion 15 generally includes a small draft angle along its cylindrical portion to assure easy entrance and release with respect to bore 20 as well as for sealing action around rib 30. Because rib 30 is capable of radially deforming to conform to irregularities in the diameter or roundness of the side wall of nose 15, an air-tight seal is obtained without reliance solely upon deformation of the sidewall of cylindrical portion 14 or pressure between nose end 19 and collar 17.

In an automated pipetting operation it is important to maintain a controlled distance from the end of the pipette tip to a known level in a microtiter well. It is essential to extract all liquid from a pipette tip either within conical section 11, or that adhering to the outer surface to obtain reproducible results, particularly with cell culture supernatants. To permit such action to occur in an automatic liquid transfer system, wherein tips of the present invention are particularly useful, capillary forces between liquids and the dispensing end are used. This requires that the distance be both known and reproducible to within several hundredths cm. It will be apparent from the foregoing description that such preciseness in axial distance is readily obtained without undue friction

between the tip and pipette barrel, either for insertion on, or displacement from, the pipette. At the same time such friction between circumferential rib 30 and barrel 16 is fully adequate to form an air seal under adverse conditions to maintain fully effective operation of pump plunger 22 to take in or dispense known quantities of liquid over a range of from a microliter or less to several hundred microliters.

Figure 6 illustrates alternate embodiments in the sealing and seating arrangements of the present invention. As indicated in cross section seating collar 17 may be formed as a plurality of ledges 47 which are molded into tip 10 to form a fixed end seat for end 19. Desirably three or more, preferably four, ledges 47 are used in such an embodiment. As further indicated sealing between bore 20 and the cylindrical sidewall of nose 15 may be provided by an O-ring 48 seated in groove 49 formed in nose 15. Figure 6 also illustrates that nose 15 may be formed with a slightly tapered end portion 50 which may be spherical in configuration. Alternatively the taper of portion 50 may be conical and the end slightly chamfered to permit easy alignment and passage of nose end 19 into tip 10, including an integrally formed sealing rib.

It will also be apparent that if desired O-rings could be seated in the sidewall of bore 20 of tip 10 to form the required low friction annular seal with barrel nose 15.

While in the preferred embodiments only two circumferential sealing arrangements are shown, it will be apparent that additional sealing ribs of similar configurations may be added to bore wall 20 or to nose 15, provided the overall friction limitations for installation and stripping of the tips is not exceeded.

Claims

1. A disposable pipette tip comprising an elongated conical tube, the small end of which defines a passageway for liquid and the large end of which  
5 receives the end of a pipette, characterized in that the tip includes a generally cylindrical collar for receiving the end of the pipette, the collar being axially aligned with and opening into the large end of the conical tube and having a stop for engaging the  
10 pipette to fix an accurately controlled distance from the end of the pipette to the small end of the pipette tip, and a circumferential seal for forming a friction fit and seal with the sidewall of the pipette.

2. The disposable pipette tip of claim 1  
15 further characterized in that the stop is a shoulder at the junction of the generally cylindrical section and the large end of the conical tube and/or one or more radial projections within the collar and/or is defined by a rim at the mouth of the collar.

20 3. The disposable pipette tip of claim 1 or 2 wherein the circumferential seal is a rib and/or is defined by a slow taper in the internal sidewall of the collar.

25 4. The disposable pipette tip of claim 1, 2, or 3 further characterized in that the collar has a larger diameter than the large end of the conical tube.

5. The disposable pipette tip of claim 1, 2, 3, or 4 further characterized in that the collar has a draft angle of less than  $2^\circ$  toward its mouth and the mouth is bell shaped for receiving the pipette.

5                   6. The disposable pipette tip of claim 1, 2,  
3, 4, or 5 further characterized in that the outer  
surface of the tip has three or more support splines  
that are substantially parallel to the tip axis and  
terminate just above the axial center of gravity of the  
10 tip.

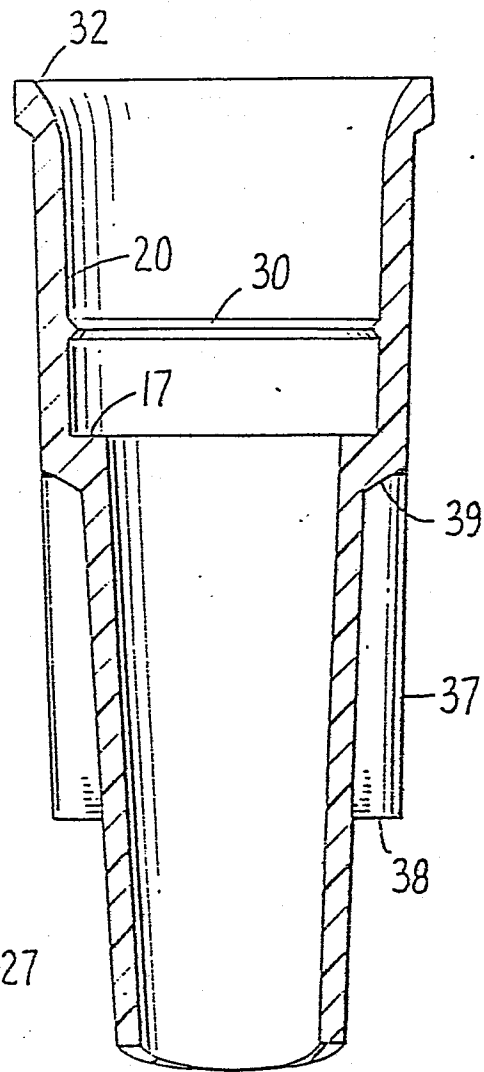
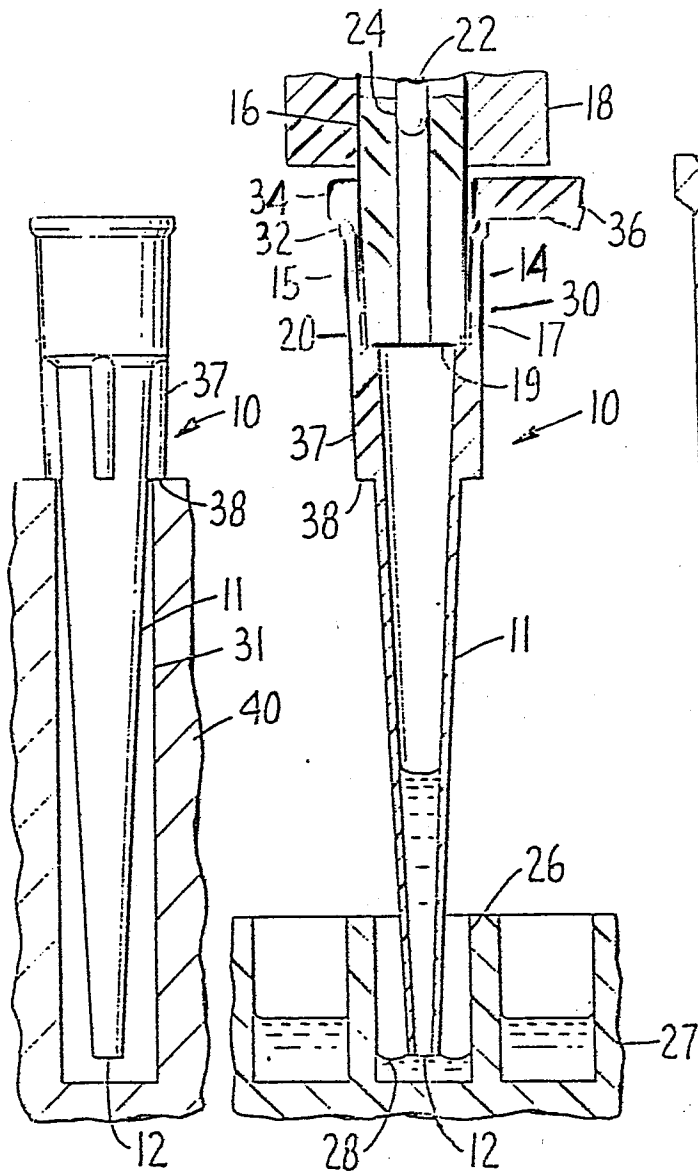

FIG. 1. FIG. 2.

FIG. 3.

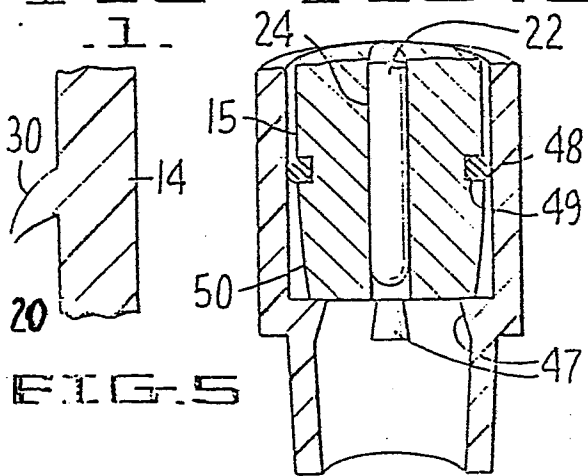

FIG. 5

FIG. 6.

FIG. 4.



DOCUMENTS CONSIDERED TO BE RELEVANT				
Category	Citation of document with indication, where appropriate, of relevant passages	Relevant to claim	CLASSIFICATION OF THE APPLICATION (Int. Cl.4)	
X	US-A-3 760 639 (SOKOL et al.) * Column 2, lines 13-17; figures 2,3 *	1-4	B 01 L 3/02	
Y	---	5,6		
Y	DE-A-2 114 108 (OLLITUOTE OY) * Page 3, line 19 - page 4, line 12 *	5		
Y	FR-A-2 313 982 (EPPENDORF GERÄTE-BAU) * Page 5, lines 33-37 *	6		
				TECHNICAL FIELDS SEARCHED (Int. Cl.4)
X	FR-A-2 021 566 (BIO-DYNAMICS INC.) * Page 4, lines 6-12; figure 3 *	1-4		B 01 L
X	FR-A-2 305 713 (FAURE) * Page 3, lines 2-5 *	1-4		
The present search report has been drawn up for all claims				
Place of search THE HAGUE		Date of completion of the search 10-01-1985	Examiner VAN OORSCHOT J.W.M.	
CATEGORY OF CITED DOCUMENTS		T : theory or principle underlying the invention E : earlier patent document, but published on, or after the filing date D : document cited in the application L : document cited for other reasons & : member of the same patent family, corresponding document		
X : particularly relevant if taken alone Y : particularly relevant if combined with another document of the same category A : technological background O : non-written disclosure P : intermediate document				