

19



Europäisches Patentamt
European Patent Office
Office européen des brevets



11 Publication number:

0 248 488 B1

12

EUROPEAN PATENT SPECIFICATION

45 Date of publication of patent specification: **06.03.91** 51 Int. Cl.⁵: **E05B 47/06**

21 Application number: **87201019.4**

22 Date of filing: **01.06.87**

54 Locks.

30 Priority: **05.06.86 GB 8613696**

43 Date of publication of application:
09.12.87 Bulletin 87/50

45 Publication of the grant of the patent:
06.03.91 Bulletin 91/10

84 Designated Contracting States:
BE DE NL

56 References cited:
EP-A- 0 035 979
EP-A- 0 136 570
DE-A- 3 300 171
FR-A- 1 484 810
US-A- 4 262 504

73 Proprietor: **Chubb Lips Nederland BV**
Merwedestraat 48 P.O. Box 59
NL-3300 AB Dordrecht(NL)

72 Inventor: **Van Erp, Joannes Wilhelmus**
Prunusstraat 20
NL-4941 KS Raamsdonkveer(NL)
Inventor: **Hordijk, Johan Cornelis**
Giethuizerf 66
NL-4901 NB Oosterhout(NL)

74 Representative: **Obee, Robert William**
Racal Group Services Ltd. Group Legal De-
partment Richmond Court 309 Fleet Road
Fleet, Hants. GU13 8BU(GB)

EP 0 248 488 B1

Note: Within nine months from the publication of the mention of the grant of the European patent, any person may give notice to the European Patent Office of opposition to the European patent granted. Notice of opposition shall be filed in a written reasoned statement. It shall not be deemed to have been filed until the opposition fee has been paid (Art. 99(1) European patent convention).

Description

The present invention relates to locks.

More particularly the invention seeks to provide a lock which, while normally operable only by authorised key-holders also has a provision for release electrically in response to a signal from a remote control station. A need for locks having this facility arises, for example, in corrective institutions or other secure buildings where passage through specified doors is usually to be restricted to authorised personnel but where, in the event of fire or some other emergency, it is necessary to unlock the doors quickly under central control to permit the egress of all persons in the locality.

From EP-A-0 035 979, upon which the preamble of claim 7 is based, there is known a lock for sliding gates with a hook bolt which can be unlocked by a release member acted upon by a compressed spring. The spring can be released to act upon the release member either by energisation of a solenoid or by turning a key in a cylinder, in either case the same action of the release member occurring. The spring is compressed and the mechanism automatically reset to its locking condition upon subsequent closure of the gate, through depression of a plunger which abuts against the gate post. This lock is not suitable for the kind of service indicated above, however, on account of its automatic locking whenever the gate is closed. In the emergency release situation with which the present invention is concerned, it is desirable that subsequent locking should be under the control only of authorised keyholders to avoid the possibility of non-keyholders becoming trapped in areas from which, in a specified emergency, they are intended to have egress.

The invention accordingly provides a lock comprising: a bolt movable between locking and unlocking positions and means for blocking movement of the bolt from its locking to its unlocking position; a key-recognition mechanism with means whereby said blocking means can be released and the bolt moved between its locking and unlocking positions by turning a correct key; a release member separate from the bolt and spring means biasing that member to move in a sense in which it can release said blocking means and move the bolt from its locking to its unlocking position; a detent member normally holding said release member in an inoperative position; and an electromagnetic actuator adapted, when energised, to release the detent member to permit the release member to move in the aforesaid sense under the force of said spring means; characterised in that said release member constitutes an emergency release member which in its inoperative position is unaffected by normal operation of the key-recognition mechanism and

which is adapted to release said blocking means and move the bolt from its locking to its unlocking position independently of the key-recognition mechanism when said actuator is energised; and means are provided whereby subsequent turning of the correct key in the sense to move the bolt to its locking position is effective to reset the emergency release member to its said inoperative position.

These and other features of the present invention will now become more apparent from the following description of a preferred embodiment of a lock in accordance with the invention, given by way of example, and taken in conjunction with the accompanying drawings, in which:

Figure 1 shows the mechanism of a lock according to the invention, with its cap broken away;

Figure 2 shows, to an enlarged scale, the runner of the lock in Figure 1;

Figure 3 is a view on the arrow III of Figure 2;

Figure 4 shows the bolt of the lock in Figure 1;

Figure 5 shows the emergency release lever of the lock in Figure 1;

Figure 6 shows the detent lever of the lock in Figure 1;

Figure 7 is a view on the arrow VII of Figure 6; and

Figure 8 shows the reset member of the lock in Figure 1.

The lock illustrated in Figure 1 is a mortice lock having a forend 1 and a case 2 closed by a cap 3. It includes a reciprocable latch bolt 4 which can be withdrawn against its spring bias 5 by handles (not shown) on both sides of the door linked to a follower 6 by the usual square-sectioned spindle. A return spring 7 acts on the follower 6 via a tie 8.

The lock also includes a reciprocable dead bolt 9 the movement of which is normally under the control of a locking cylinder (not shown) mounted through the aperture 10 in the case and cap. More particularly the cylinder acts through a runner 11 (see also Figures 2 and 3) which is borne by a pair of pegs 12 to move along an arcuate track 13 in the case 2. Figure 1 shows the bolt 9 in its extended position in which it is deadlocked by a pin 14 upstanding from the runner 11 lying behind a surface 15 of the plate-like tail of the bolt (see also Figure 4). To withdraw the bolt the correct key is turned in the locking cylinder through 360° in the clockwise sense (as viewed in Figure 1) so that a thrower (not shown) on the cylinder engages the drive face 16 of the runner 11 and moves the runner clockwise to the opposite end of its track 13, in so doing the runner pin 14 engaging the drive face 17 of the bolt 9 and drawing the bolt back into the case. The mechanism finishes with the pin 14 lying in front of the face 18 of the bolt tail to block extension of the bolt. To throw the bolt

once more the correct key must be turned in the cylinder in the anticlockwise sense (as viewed in Figure 1) so that its thrower engages the drive face 19 of the runner 11 to move the latter anticlockwise along the track 13 to its Figure 1 position, in so doing the runner pin 14 engaging the drive face 20 of the bolt 9 to shift the bolt and finishing in its deadlocking position behind the face 15. A spring finger 21 acts on the runner 11 throughout, to resist accidental movement. The principle of operation of this bolt-throwing and deadlocking mechanism is described also in Dutch patent specification no. 174973.

While withdrawal of the dead bolt 9, and hence unlocking of the door to which the lock is fitted, is normally available only to authorised keyholders, the lock also includes provision whereby, in a emergency, the bolt can be withdrawn under remote control from a central station, so that the door can then be opened by any person withdrawing the latch bolt 4 with the associated handle.

To this end the mechanism includes an emergency release lever 22 (see also Figure 5) pivoted at 23 in the case and acted upon by a relatively strong spring 24 urging the lever to turn in the anticlockwise sense (as viewed in Figure 1). Normally this lever is held in its inoperative position shown in Figure 1, by means of a second, detent lever 25 (see also Figures 6 and 7). More particularly, the lever 25 is generally L-shaped and is pivoted on a pin 26 in the case. The shorter arm 27 of the lever 25 has a slot in its end by which it is linked to the armature 28 of a solenoid 29. The longer arm 30 of the lever 25 also has a slot 31 within which is received the head 32 of the lever 22. This part of the lever 22 has a notch 33 which interlocks with the lever 25, so as to hold both the lever 22 against the anticlockwise bias of its spring 24 and the lever 25 against an anticlockwise bias applied to it by a spring 34 on the solenoid 29.

In the position of Figure 1 the lever 22 has no effect upon the operation of the deadbolt 9. It will be noted that the foot 35 of the lever lies adjacent to, but slightly spaced from, the runner pin 14 when in its deadlocking position, and the lever does not interfere with the extension and retraction of the bolt 9 under the control of the locking cylinder. When remote-controlled withdrawal of the dead bolt 9 is required, however, the following action takes place.

That is to say, an electrical pulse is supplied from the central station to the solenoid 29 via a cable 36, to momentarily withdraw the armature 28 into the solenoid. This pivots the lever 25 clockwise about its pin 26 so that the arm 30 releases the lever 22. The latter is now free to turn anticlockwise under the action of the spring 24 and as it turns the foot 35 of the lever engages the runner pin 14 to

draw back the runner 11, and hence the dead bolt 9, to its withdrawn position, thereby unlocking the door.

When the lever 25 is released by the solenoid 29 it also is free to turn anticlockwise under the bias of its spring 34 until the end of the arm 30 abuts the inclined face 37 of the lever 22. From this position the mechanism can be reset by turning the lever 22 back against its spring 24, thus causing the lever 25 also to turn back against its spring 34 and sliding the arm 30 along the face 37 until the levers click back into their interlocked position shown in Figure 1. This resetting movement will take place the next time that the bolt 9 is thrown again by the locking cylinder. As the cylinder thrower drives the runner 11 back to its deadlocking position so the runner pin 14 drives back the lever 22. It is necessary, however, to move the lever 22 further than the resting position of the pin 14 in order to re-engage its head 32 in the notch 31 of lever 25. For this purpose an additional reset member 38 is provided (see also Figure 8). This member comprises an arm pivoted on a pin 39 in the case and articulated to the lever 22 through a pin and slot coupling 40/41, so as to pivot clockwise about its pin 39 as the lever 22 pivots anticlockwise about its pin 23, and vice versa. During the final part of the throwing movement of the cylinder, after its thrower has left the drive surface 19 of the runner 11, the cylinder thrower engages the belly 42 of the member 38 to pivot the latter anticlockwise through a few more degrees and so take the lever 22 back to its interlocked position with the lever 25.

An advantage of the mechanism described above is that only a short pulse of electrical energy to the solenoid 29 is required in order to trigger release of the lever 22, and the force for emergency withdrawal of the bolt 9 comes from a spring 24 rather than from the solenoid itself, so power-consumption is very low. The geometry of the lever 25 means that the armature 28 need move through only a small distance, corresponding to the position of maximum attraction within the operational characteristics of a conventional solenoid, so that reliability in triggering the lever 22 is ensured. Furthermore, the free distance through which the lever 22 is permitted to move before its foot 35 encounters the runner pin 14 means that there is no danger of the lever 25 relocking the lever 22 if the solenoid is de-energised before the lever 22 has had a chance to move the runner 11. Such circumstances could arise if, for example, a person is pushing upon the door at the moment when the lever 22 is triggered. The lateral force on the bolt 9 could then cause sufficient friction to prevent the spring force on the lever 22 from withdrawing the bolt - until, that is, the force on the door is relieved

at which point the lever will automatically move to withdraw the bolt. This is another advantage of employing the stored energy of a spring to withdraw the bolt as opposed to the energy of a solenoid direct.

Reference numeral 43 in the drawing denotes a microswitch for giving a remote indication of the withdrawn condition of the bolt 9.

Claims

1. A lock comprising: a bolt (9) movable between locking and unlocking positions and means (14) for blocking movement of the bolt (9) from its locking to its unlocking position; a key-recognition mechanism (10) with means (11) whereby said blocking means (14) can be released and the bolt (9) moved between its locking and unlocking positions by turning a correct key; a release member (22) separate from the bolt (9) and spring means (24) biasing that member (22) to move in a sense in which it can release said blocking means (14) and move the bolt (9) from its locking to its unlocking position; a detent member (25) normally holding said emergency release member (22) in an inoperative position; and an electromagnetic actuator (29) adapted, when energised, to release the detent member (25) to permit the emergency release member (22) to move in the aforesaid sense under the force of said spring means (24); characterised in that said release member (22) constitutes an emergency release member which in its inoperative position is unaffected by normal operation of the key-recognition mechanism (10) and which is adapted to release said blocking means (14) and move the bolt (9) from its locking to its unlocking position independently of the key-recognition mechanism (10) when said actuator (29) is energised; and means (38) are provided whereby subsequent turning of the correct key in the sense to move the bolt (9) to its locking position is effective to reset the emergency release member (22) to its said inoperative position.
2. A lock according to claim 1 wherein, following release of the detent member (25), the emergency release member (22) is permitted a limited extent of free movement under the force of the spring means (24) before commencing its release of the blocking means (14) and movement of the bolt (9), whereby momentary energisation of the electromagnetic actuator (29) is sufficient to allow the emer-

gency release member (22) to move to a position in which it cannot be re held by the detent member (25) following de-energisation of the electromagnetic actuator (29) even if said commencement of the release of the blocking means (14) and movement of the bolt (9) is inhibited.

3. A lock according to claim 1 or claim 2 comprising a reset member (38) operable through the key-recognition mechanism (10) which is adapted to move the emergency release member (22) back to its inoperative position, beyond the position in which the emergency release member (22) can be set by the blocking means (14) when the latter is moved to the position in which it blocks the bolt (9) in its locking position.
4. A lock according to any preceding claim wherein the emergency release member (22) is in the form of a generally L-shaped lever, a shorter arm (32) of which is adapted to engage with the detent member (25) and a longer arm (35) of which is adapted to engage with the blocking means (14).
5. A lock according to any preceding claim wherein the detent member (25) is in the form of a generally L-shaped lever, a shorter arm (27) of which is adapted to engage with the electromagnetic actuator (29) and a longer arm (30) of which is adapted to engage with the emergency release member (22).
6. A lock according to any preceding claim wherein the key-recognition mechanism (10) cooperates with a runner (11) movable along an arcuate path and having an abutment (14) for engagement with drive surfaces (17, 20) on the bolt (9) for moving the latter between its locking and unlocking positions, said abutment (14) also constituting said blocking means.

Revendications

1. Serrure comprenant un pêne (9) déplaçable entre des positions de verrouillage et de déverrouillage et des moyens (14) pour bloquer le mouvement du pêne (9) depuis sa position de verrouillage vers sa position de déverrouillage, un mécanisme de reconnaissance de clef (10) pourvu de moyens (11) par lesquels lesdits moyens de blocage (14) peuvent être libérés et le pêne (9) déplacé entre ses positions de verrouillage et de déverrouillage par rotation d'une clef correcte, un organe de libéra-

tion (22) séparé du pêne (9) et des moyens de ressort (24) rappelant cet organe (22) de façon qu'il se déplace dans un sens dans lequel il peut libérer lesdits moyens de blocage (14) et déplacer le pêne (9) depuis sa position de verrouillage jusqu'à sa position de déverrouillage, un organe de détente (25) maintenant normalement ledit organe de libération (22) dans une position inopérante et un organe d'actionnement électromagnétique (29), qui est adapté, lorsqu'il est excité, pour libérer l'organe de détente (25) afin de permettre le déplacement de l'organe de libération (22) dans le sens précité sous la force desdits moyens de ressort (24), caractérisée en ce que ledit organe de libération (22) forme un organe de libération d'urgence qui, dans sa position inopérante, n'est pas affecté par une mise en oeuvre normale du mécanisme de reconnaissance de clef (10) et qui est adapté pour libérer les moyens de blocage (14) et pour déplacer le pêne (9) de sa position de verrouillage à sa position de déverrouillage indépendamment du mécanisme de reconnaissance de clef (10) lorsque ledit organe d'actionnement (29) est excité, et en ce qu'il est prévu des moyens (38) par lesquels une rotation ultérieure de la clef correcte dans le sens de déplacement du pêne (9) vers sa position de verrouillage est efficace pour ramener l'organe de libération d'urgence (22) à ladite position inopérante de celui-ci.

2. Serrure suivant la revendication 1 dans laquelle, après la libération de l'organe de détente (25), l'organe de libération d'urgence (22) peut effectuer un degré limité de mouvement libre sous la force des moyens de ressort (24) avant l'amorce de la libération des moyens de blocage (14) et un mouvement du pêne (9), une excitation momentanée de l'élément d'actionnement électromagnétique (29) étant suffisante pour permettre à l'organe de libération d'urgence (22) de se déplacer vers une position dans laquelle celui-ci ne peut pas être retenu par l'organe de détente (25) après désactivation de l'organe d'actionnement électromagnétique (29) même si ladite amorce de la libération des moyens de blocage (14) et le déplacement du pêne (9) sont inhibés.
3. Serrure suivant la revendication 1 ou 2 comprenant un organe de remise à la condition initiale (38) pouvant être mis en oeuvre par le mécanisme de reconnaissance de clef (10), qui est adapté pour ramener l'organe de libération d'urgence (22) à sa position inopérante, au-delà de la position dans laquelle l'organe de libération d'urgence (22) peut être placé par

les moyens de blocage (14) lorsque ces derniers sont déplacés vers la position dans laquelle ils bloquent le pêne (9) dans sa position de verrouillage.

4. Serrure suivant l'une quelconque des revendications précédentes dans laquelle l'organe de libération d'urgence (22) présente la forme d'un levier généralement en forme de L, dont le bras court (32) est adapté de manière à entrer en prise avec l'organe de détente (25) et dont le bras long (35) est adapté de manière à entrer en prise avec les moyens de blocage (14).
5. Serrure suivant l'une quelconque des revendications précédentes, dans laquelle l'organe de détente (25) présente la forme d'un levier généralement en forme de L, dont le bras court (27) est adapté de manière à entrer en prise avec l'organe d'actionnement électromagnétique (29) et dont le bras long (30) est adapté de manière à entrer en prise avec l'organe de libération d'urgence (22).
6. Serrure suivant l'une quelconque des revendications précédentes, dans laquelle le mécanisme de reconnaissance de clef (12) coopère avec un curseur (11), qui est déplaçable le long d'une piste arquée et qui présente une butée (14) destinée à entrer en prise avec des surfaces d'entraînement (17, 20) situées sur le pêne (9) pour déplacer ce dernier entre ses positions de verrouillage et de déverrouillage, ladite butée (14) formant également lesdits moyens de blocage.

Ansprüche

1. Schloß, welches beinhaltet: einen Bolzen (9), bewegbar zwischen Schließ- und Öffnungsstellungen und eine Vorrichtung (14) zur Blockierung der Bewegung des Bolzens (9) von seiner Schließstellung in seine Öffnungsstellung; ein Schlüsselerkennungsmechanismus (10) mit einer Vorrichtung (11), durch welche die genannte Blockier Vorrichtung (14) gelöst und der Bolzen (9) durch Drehen eines passenden Schlüssels zwischen Schließ- und Öffnungsstellungen bewegt werden kann; ein vom Bolzen (9) getrenntes Auslösebauteil (22) und eine Feder Vorrichtung (24), welche dieses Bauteil (22) zwingt, sich in eine Richtung zu bewegen, in der es die genannte Blockier Vorrichtung (14) lösen und den Bolzen (9) von seiner Schließ in seine Öffnungsstellung bewegen kann; ein Rückhalteteil (25), das normalerweise besagtes

- Auslösebauteil (22) in einer wirkungslosen Stellung hält; und einen elektromagnetischen Antrieb (29), der so ausgelegt ist, daß er, bei Aktivierung, das Rückhalteteil (25) auslöst, um dem Auslösebauteil (22) zu erlauben, sich unter der Kraft der genannten Federvorrichtung (24) in die zuvor genannte Richtung zu bewegen; **gekennzeichnet** dadurch, daß das genannte Auslösebauteil (22) einen Notfallauslöser darstellt, der in seiner wirkungslosen Stellung von der normalen Bedienung des Schlüsselerkennungssystems (10) nicht beeinflusst wird und der so ausgelegt ist, daß er, unabhängig vom Schlüsselerkennungsmechanismus (10), die genannte Blockiervorrichtung (14) löst und den Bolzen (9) von seiner Schließ- in seine öffnungsstellung bewegt, wenn der genannte Auslöser betätigt wird; und Vorrichtungen (38) vorgesehen sind, bei denen das nachfolgende Drehen des passenden Schlüssels in die Richtung, bei der der Bolzen (9) in seine Schließstellung bewegt wird, wirksam ist, um das Notfallauslösebauteil (22) zurück in seine wirkungslose Stellung zu setzen.
2. Schloß gemäß Anspruch 1, bei dem nach Auslösen des Rückhalteteils (25) dem Notfallauslösebauteil (22) ein beschränktes Maß an freier Bewegung unter der Kraft der Federvorrichtung (24) gewährt wird, bevor sein Auslösen der Blockiervorrichtung (14) und die Bewegung des Bolzens (9) beginnt, wobei eine kurzzeitige Aktivierung des elektromagnetischen Antriebs (29) genügt, um dem Notfallauslösebauteil (22) zu gestatten, in eine Stellung zu kommen, in der es nach Deaktivierung des elektromagnetischen Antriebs (29) nicht vom Rückhalteteil (25) zurückgehalten werden kann, auch wenn der Beginn des Auslösens der Blockiervorrichtung (14) und die Bewegung des Bolzens (9) verhindert werden.
3. Schloß gemäß Anspruch 1 oder 2, das ein mit Hilfe des Schlüsselerkennungsmechanismus (10) betätigbares Rückstellbauteil (38) enthält, welches so ausgelegt ist, daß es das Notfallauslösebauteil (22) zurück in seine wirkungslose Stellung bringt, über die Stellung hinaus, in die das Notfallauslösebauteil (22) durch die Blockiervorrichtung (14) gebracht werden kann, wenn letztere in die Stellung gebracht wird, in der sie den Bolzen (9) in der Schließstellung verriegelt.
4. Schloß gemäß einem der vorangehenden Ansprüche, in dem das Notfallauslösebauteil (22) die Form eines im wesentlichen L-förmigen Hebels aufweist, dessen kürzerer Arm (32) so

ausgelegt ist, daß er in das Rückhalteteil (25) eingreift und dessen längerer Arm (35) so ausgelegt ist, daß er in die Blockiervorrichtung (14) eingreift.

5. Schloß gemäß einem der vorangehenden Ansprüche, in dem das Rückhalteteil (25) die Form eines im wesentlichen L-förmigen Hebels aufweist, dessen kürzerer Arm (27) so ausgelegt ist, daß er in den elektromagnetischen Antrieb (29) eingreift und dessen längerer Arm (30) so ausgelegt ist, daß er in das Notfallauslösebauteil (22) eingreift.
6. Schloß gemäß einem der vorangehenden Ansprüche, bei dem der Schlüsselerkennungsmechanismus (12) mit einem Läufer (11) zusammenwirkt, der sich entlang eines gekrümmten Wegs bewegen läßt und der einen Anschlag (14) zum Eingriff mit den Antriebsflächen (17, 20) auf den Bolzen (9) besitzt, um letzteren zwischen Schließ- und öffnungsstellung zu bewegen, wobei besagter Anschlag (14) ebenso Teil der genannten Blockiervorrichtung ist.

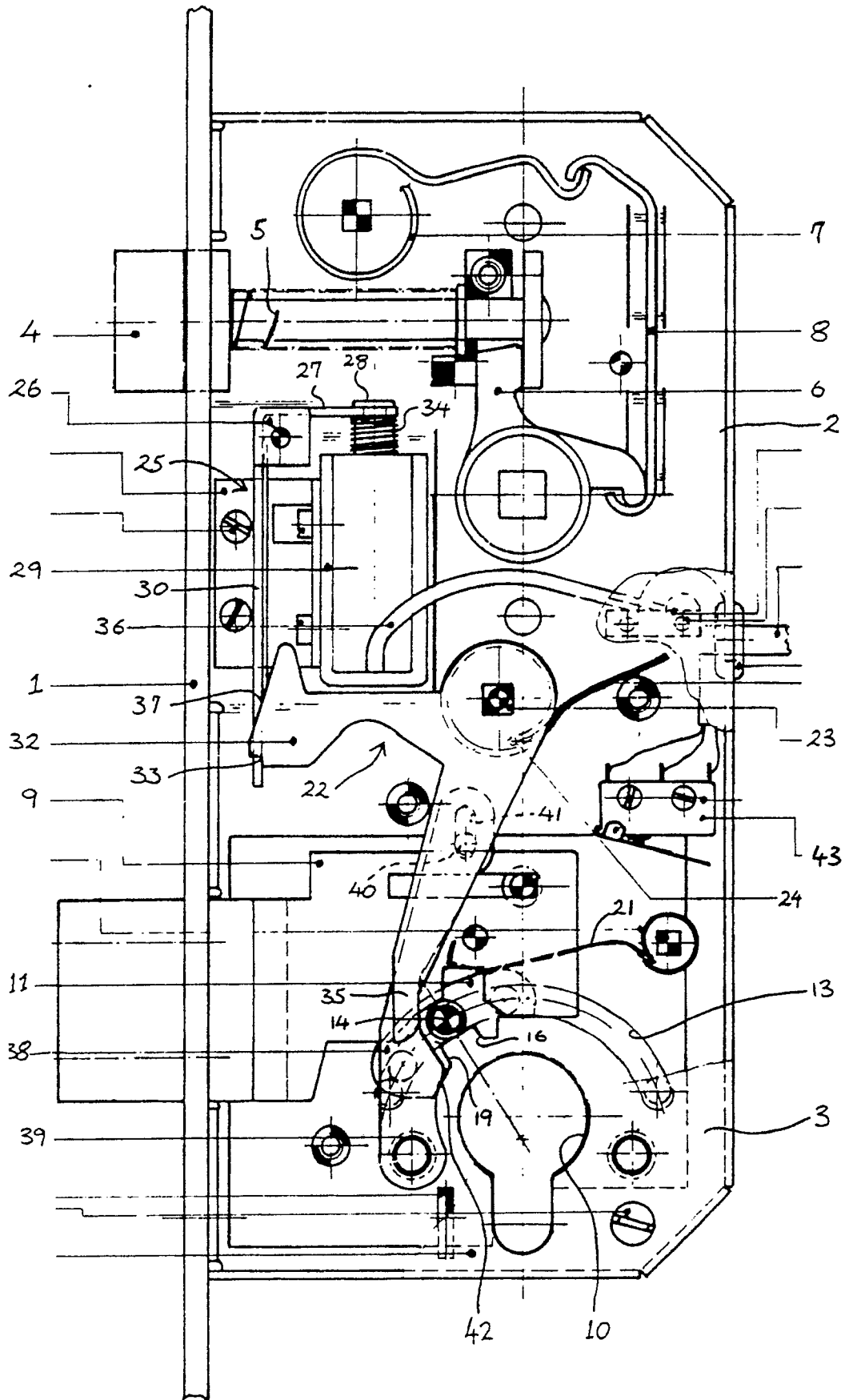

Fig. 1.

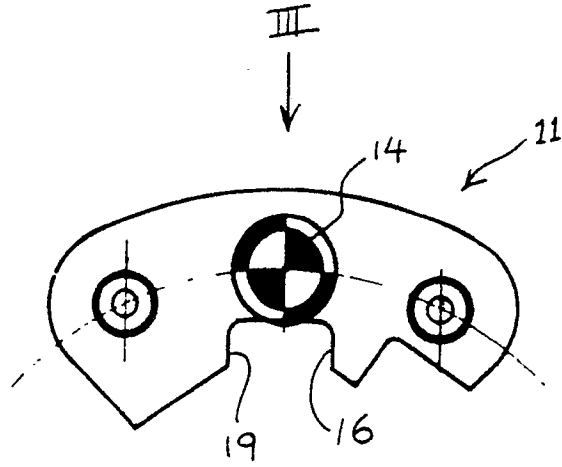

Fig 2

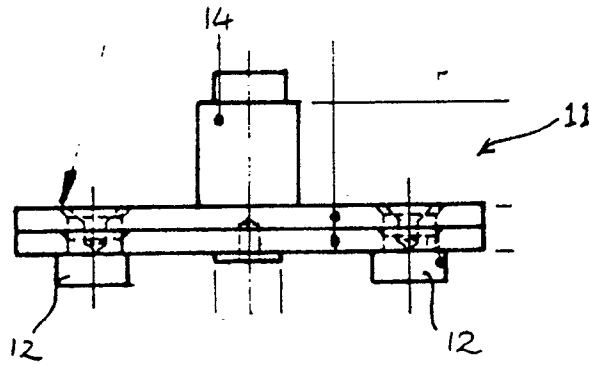

Fig 3

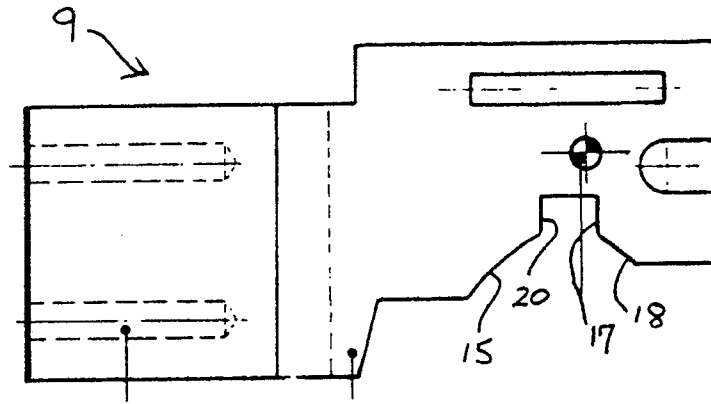

Fig. 4

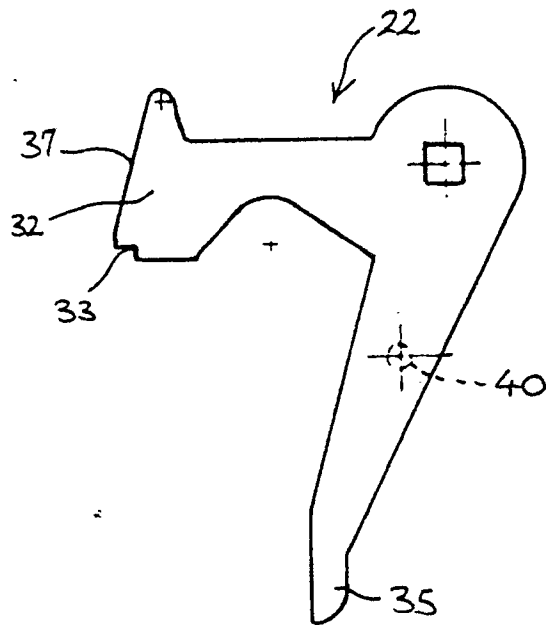

Fig. 5

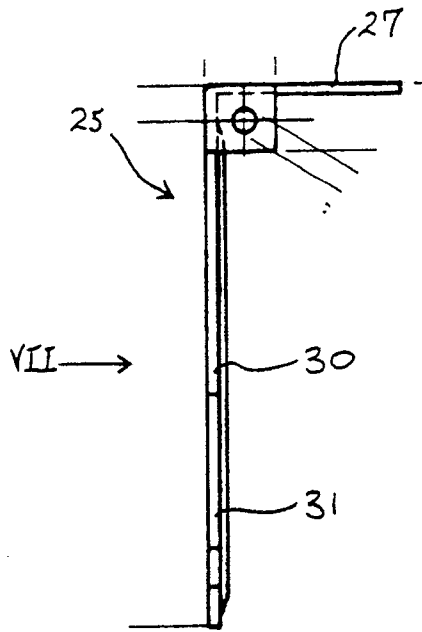

Fig 6

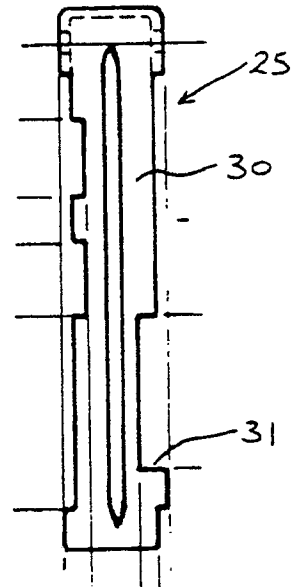

Fig 7

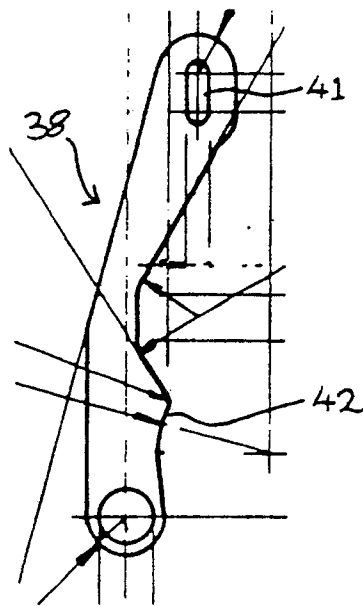

Fig 8