

(19)  
(12)

(KR)  
(Y1)

(51) 。 Int. Cl.7  
B60Q 1/04

(45)  
(11)  
(24)

2003 10 08  
20-0329143  
2003 09 26

(21) 20-2003-0019522  
(22) 2003 06 20

(73) 2 621-50

(72) 2 621-50

(74)

:

가 :

(54)

( )	(眼球)	(7)	(8)	(9)
( )	(1)	(2)		12
14volt	(5) (2)	(2)	200	700volt
	(invertor; )(4)			
(2)	가	(2)	( )	
( )	(2)			

1

1

2 1 A

\* \*

1 : 2 :

4 : 5 :

7 : 8 :

9 : 10 :

(眼球)

( )

(10)가 (7), (8) (9)

( )

(7), (8) (9) (1)  
(2) 12 14volt (5) (2) (2)  
) 200 700volt (invertor; )(4) (2)

가 (2) 2 4mm 가

가 (10) (2) ( )  
(5) 12 14volt (2)

200 700volt (2)  
 700 800volt (4) (5) (  
 1) (2) 1 (7)(8)(9) (2) (7), (8) (9)  
 (2)

( )

(57)

1. (7), (8) (9) (1)  
 (2) 12 14volt (5) (2) (2)  
 200 700volt (invertor; )(4)

1

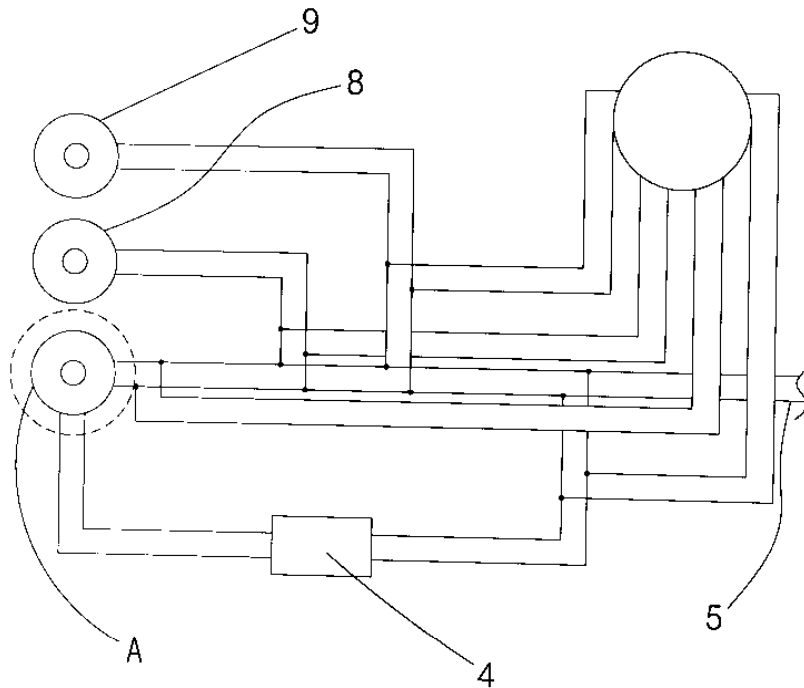

2

