

(No Model.)

M. L. BAKER.

GATE.

No. 386,230.

Patented July 17, 1888.

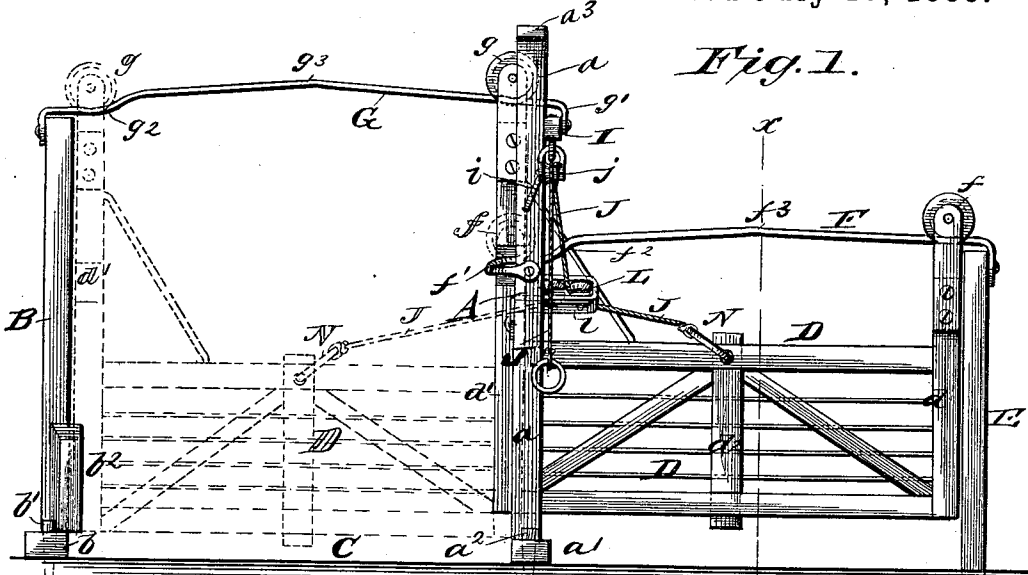

Fig. 1.

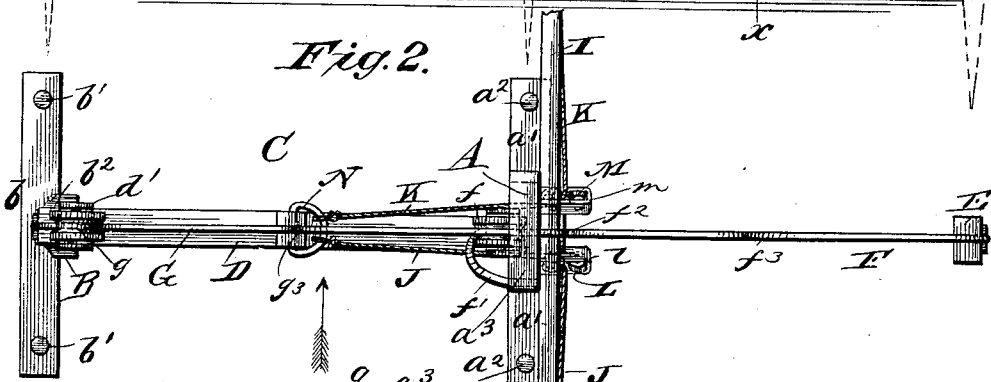

Fig. 2.

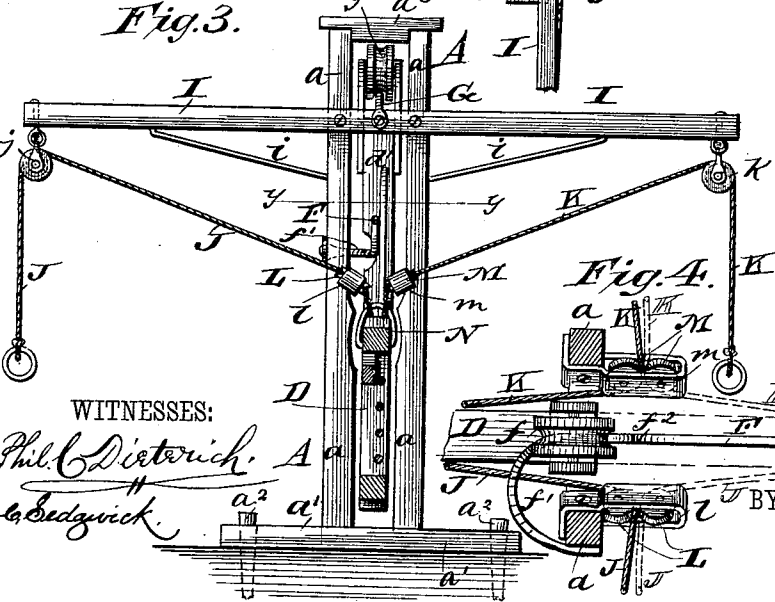

Fig. 3.

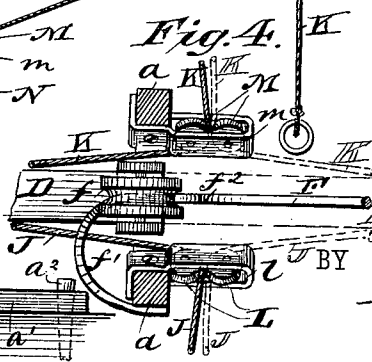

Fig. 4.

WITNESSES:

Phil. Dietrich.  
C. Sedgwick.

INVENTOR:

M. L. Baker

Munn & Co.

ATTORNEYS.

# UNITED STATES PATENT OFFICE.

MARTIN LUTHER BAKER, OF WILTON JUNCTION, IOWA.

## GATE.

SPECIFICATION forming part of Letters Patent No. 386,230, dated July 17, 1888.

Application filed January 28, 1888. Serial No. 262,234. (No model.)

*To all whom it may concern:*

Be it known that I, MARTIN LUTHER BAKER, of Wilton Junction, in the county of Muscatine and State of Iowa, have invented a new and Improved Gate, of which the following is a full, clear, and exact description.

My invention has for its object to provide a simple, inexpensive, and substantial farm-gate, which may be opened and closed quickly and easily by a person on a vehicle or on horseback, by simply pulling cords at the roadside. The gate is automatically held or latched as it closes to prevent opening of it by stock, and will not be obstructed by ordinary storms.

The invention consists in certain novel features of construction and combinations of parts of the gate, all as hereinafter described and claimed.

Reference is to be had to the accompanying drawings, forming a part of this specification, in which similar letters of reference indicate corresponding parts in all the figures.

Figure 1 is an aside elevation of the gate, shown open in full lines and closed in dotted lines. Fig. 2 is a plan view of the gate in closed position. Fig. 3 is an end view with the gate proper in vertical section on the line  $x x$  in Fig. 1; and Fig. 4 is an enlarged detail plan view at the main gate-post, which is shown in horizontal section.

The main post A and one side post, B, of the gate are set at opposite sides of a road, C, which the gate proper, D, is intended to close or open, and the other shorter post, E, is set at the other side of the main post as a support to the gate and to stop it when open. The main post A consists of two uprights,  $a a$ , which are preferably framed into a sill-timber,  $a'$ , which rests on a foundation, to which it is held by pins or stakes  $a^2$ , and the tops of the uprights  $a a$  are connected and at the same time stayed apart by a head-piece,  $a^3$ , said uprights  $a a$  being separated sufficiently to allow the gate D to run between them in a manner presently explained. The post B is preferably framed into a sill,  $b$ , which rests on a foundation, and is held thereto by pins or stakes  $b'$ , while the other side post, E, is simply set or driven into the earth, as it partially supports the gate D only when the latter is open. Plates or cheek-pieces  $b^2 b^2$ , fixed to the post B, pre-

vent lateral play of the outer end of the gate when it is closed.

The body of the gate D may have any ordinary or approved construction. It is shown made with wooden uprights  $d d' d^2$ , and longitudinal rails and diagonally-ranging braces, with wire or metal stringers between the rails. The outer end upright,  $d$ , of the gate D is shorter than its other end upright,  $d'$ , and these parts  $d d'$  carry at their upper ends rollers  $f g$ , respectively, which travel upon metal tracks or rails F G.

The track F is fixed at one end to the post E, and at its other end is passed between the uprights  $a a$  of the post A, and is then bent around at  $f'$  and is fixed to one of these uprights. Near its bent end  $f'$  the track F is depressed at  $f^2$ , and at a point,  $f^3$ , about midway between the gate-posts A E, the track is highest, whence the track inclines gradually to its depression  $f^2$  and the post E. The track G is fixed at one end to the post B and extends across the road C and between the uprights  $a a$  of the post A, and is fixed at its other end at  $g'$  to a bar, I, which is fastened to the post A and ranges lengthwise of the roadway C for some distance for attachment of the gate-operating cords, as presently explained. The track G is provided with a depression,  $g^2$ , next the post B, and is highest at a point,  $g^3$ , about midway between the posts A B.

The bar I is preferably stayed to the post A by braces  $i i$ , and at opposite ends carries pulleys or sheaves  $j k$ , through or over which are passed the cords J K, respectively, which are passed between pairs of guide-pulleys L M, journaled in strap-bearings  $l m$ , fixed to the uprights  $a a$  of the gate-post A. The inner ends of both the cords J K are attached to a stirrup or bail, N, which is pivotally connected to the upper central portion of the gate D. The pairs of pulleys L M guide the cords J K, respectively, as the gate opens and closes.

The operation of the gate is very simple and effective, and is as follows: We will suppose the gate is closed across the road C, as shown in Fig. 2 of the drawings and in dotted lines in Fig. 1, and that a person, either on a loaded vehicle or on horseback, approaches the gate in the direction of the arrow. When he reaches the pendent cord J, he will pull it sharply, and

this will first lift the gate-rollers  $f g$  from the  
 recesses  $f^2 g^2$  of the tracks F G, which will  
 raise the gate D above snow or ice on the  
 ground, and then will pull the gate open un-  
 5 til the rollers  $f g$  ride up to and over the high-  
 est parts  $f^3 g^3$  of the tracks, and the cord J be-  
 ing let go in time the gate will open the rest  
 of the way of its own accord as the rollers run  
 10 down the farthest downwardly-inclined parts  
 of the tracks and until the gate-upright  $d$  stops  
 against the post E, both the cords J K then  
 paying out beneath the outer rollers, L M.  
 After the load or horse has passed the gate-  
 way, the person will pull on the cord K, which  
 15 will close the gate again to the post B, and as  
 the gate fully closes the rollers  $f g$  will lodge  
 in the depressions  $f^2 g^2$  of the tracks F G, and  
 thereby prevent opening of the gate by stock  
 rubbing against it, these rollers and track-de-  
 20 pressions thus serving as a latch to the gate.  
 A short sharp pull on the cords J K is all that  
 is necessary to effect an easy and complete  
 opening and closing of the gate, which other-  
 wise operates automatically, allowing the gate  
 25 to be opened and closed without requiring a  
 person to leave a vehicle or dismount from a  
 horse. The track G is high enough to allow  
 full loads of hay to pass under it.

Having thus described my invention, what I  
 30 claim as new, and desire to secure by Letters  
 Patent, is—

1. The combination, with the posts A B E,  
 of the tracks F G, secured to the posts A E  
 and A B and provided with depressions  $f^2 g^2$ ,  
 35 respectively, and the gate D, provided with

rollers on the upper ends of its end uprights,  
 substantially as described.

2. The combination of the posts A B E,  
 the post E being of less height than the posts  
 A B, double-inclined track F, secured to the 40  
 posts A E and provided with the depression  
 $f^2$ , the double-inclined track G, secured to the  
 posts A B and provided with the depression  
 $g^2$ , the gate D, having its end uprights of un-  
 45 equal height and provided with the rollers  $f$   
 $g$  on the said uprights, the bar I, secured to  
 the post A, the guide-pulleys  $j k$  L M, and the  
 cords or ropes J K, attached to the gate and  
 passing over the said pulleys, substantially as  
 herein shown and described. 50

3. The combination, with the posts A B E,  
 the post E being of less height than the posts  
 A B, and the bar I, secured to post A, of the  
 double-inclined track F, provided with the  
 depression  $f^2$  and having its ends secured to 55  
 the posts A E, the double-inclined track G,  
 provided with the depression  $g^2$  and having its  
 ends secured to the post B and to the bar I,  
 the gate D, having its end posts,  $d d'$ , of un-  
 60 equal length and provided with the rollers  $f$   
 $g$ , the guide-pulleys  $j k$  in the ends of the bar  
 I, the pulleys L M in bearings on the post A,  
 and the ropes J K, connected to the center of  
 the gate and passing around the said pulleys,  
 65 substantially as herein shown and described.

MARTIN LUTHER BAKER.

Witnesses:

W. H. BAKER,

W. H. LEVERICK.