

*A. Cutter,*

*Making Barrel Heads.*

*No. 108115,*

*Patented Oct. 11. 1870.*

*Fig. 1.*

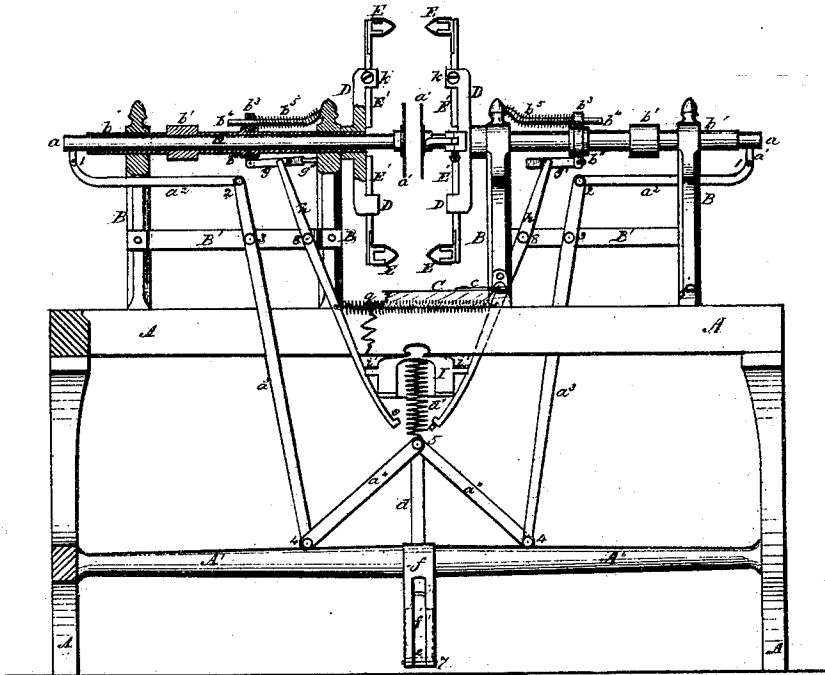

*Fig. 2.*

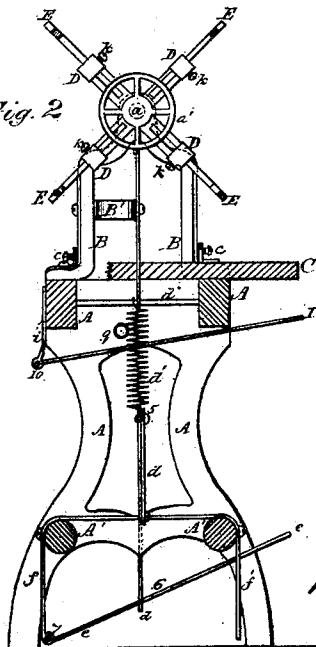

*Witnesses:*  
*John F. Fermall.*  
*J. C. Brecht.*

*Inventor:*  
*Amos Cutter*  
*By Martin Cranford*  
*his attorney*

# United States Patent Office.

AMOS CUTTER, OF BOSTON, MASSACHUSETTS.

Letters Patent No. 108,115, dated October 11, 1870.

## IMPROVEMENT IN MACHINES FOR MAKING BARREL-HEADS.

The Schedule referred to in these Letters Patent and making part of the same

I, AMOS CUTTER, of Boston, in the county of Suffolk, in the State of Massachusetts, have invented certain Improvements in Machines for Cutting Out and Finishing the Heads of Barrels, of which the following is a specification.

With the machine that I have invented the board from which the head is made is not cut into lengths, but is fed into the machine and clamped therein entire, and in position to be acted upon to cut a head, and when one head is cut the board is fed again into position, and a second head cut, and so on until a board of any convenient length is cut into barrel-heads.

The invention consists in the constructing and arranging the parts contained in the machine so that barrel-heads may be cut from a long board, without first cutting the board into bolts that will make but a single head; and

It consists, further, in the constructing and arranging the operating devices that the head shall be cut and beveled deeper on the inside than the outside; and

It consists, further, in the construction and arrangement of the devices whereby the head is clamped and held while it is being cut into the proper shape; and

It consists, further, in the construction of the revolving adjustable cutter-heads, by which barrel-heads of different diameters can be made by the same cutter-head.

In the drawing—

Figure 1 is an upright longitudinal side view of the machine, and

Figure 2 is a transverse view of the same.

A is the supporting-frame, arranged specially with relation to giving support to the several parts of the machine at the points needed.

B B are four head-stocks, arranged upon and supported by the framing A.

*a a* are two horizontal sliding rods, arranged on either side of the center of machine, having the clamping-disks *a' a'* at their inner and adjacent ends, and pass through and slide within the revolving sliding hollow shafts *b b*, and are reciprocated to force the clamps toward each other, by means of having legs drop down at their outer ends, to which are pivoted, at 1 1, bent levers *a<sup>2</sup> a<sup>2</sup>*, which are connected at 2 2 with levers *a<sup>3</sup> a<sup>3</sup>*, pivoted to brackets B' B' at 3 3, and, at their lower ends, 4 4, are hinged to angular levers *a<sup>4</sup> a<sup>4</sup>*. These angular levers meet together, and are connected to reciprocating bar *d* at 5. Bar *d*, from 5, drops down to near the bottom of frame A, and is there pivoted to treadle *e* at point 6.

Foot-treadle *e* extends back and is hinged to bracket *f* at the back side of frame A, which bracket rises up over and across the girts A' A' of the frame, and then

drops down, and has a guide-slot, *f'*, therein, which guides the foot-lever *e* in its reciprocations.

*d'* is a spiral spring, one end attached to angular levers and upright bar *d*, to open the clamp *a' a'* when the foot is taken from treadle *e*.

*b b* are horizontal revolving sliding shafts arranged on each side of the center of the machine, revolving around and upon sliding rods *a a*, and are journaled in the head-stocks B, so as to revolve freely therein, and have the revolving cutter-stocks D fast to their inner ends, and are revolved by means applied to fast pulleys *b' b'*. Near the center of their lengths are collars *b'' b''*, between which are eye-rings *b<sup>3</sup> b<sup>3</sup>*. On the upper side of these rings are holes that receive the outer ends of rods *b<sup>4</sup> b<sup>4</sup>*. Rods *b<sup>4</sup> b<sup>4</sup>* have their inner ends fast to the two inner head-stocks B, and their outer ends freely slide in the eyes on the upper sides of rings *b<sup>3</sup> b<sup>3</sup>*, and have spiral springs *b<sup>5</sup> b<sup>5</sup>* surrounding them, the inner ends of which are also fast to the middle head-stocks B, and the outer end against the eye part of rings *b<sup>3</sup> b<sup>3</sup>*.

To the under side of these eye-rings, and beneath the hollow shafts *b b*, are firmly attached notched horizontal arms *g* and *g'*. Notched arm *g* is made flexible, with its inner end inclined in such manner as that, when it is forced inward, the inclined side of its end will strike pin *g'*, and throw arm *g* out of contact with the cause that moves it. Notched arm *g'* is rigid, and holds to its position.

*h h* are inclined levers, pivoted at 8 8 to brackets B' B', their upper ends taking hold of the notches in arms *g* and *g'*, and have stops *o o* at their lower ends.

I is a treadle or lever, hinged at 10 to bracket *i*, and has flanges *i' i'* projecting from either side, in which are notches that freely slide between and against the inner edges of inclined levers *h h*.

9 is a spiral spring, placed between and attached to inclined levers *h h*, for the purpose of always keeping the levers to bear in the notches of the flanges of the treadle I and stops *o o*, at the bottom, to prevent the treadle from going below that point, and out of contact with the levers.

D D are the revolving cutter-heads, fast on the inner ends of the horizontal revolving and reciprocating shafts *b b*.

E E are cutters constructed to be adjusted on the adjustable arms E' E'.

E' E' are arms that slide in mortises in the ends of the arms of cutter-heads D, and are made to have the cutters describe any desired circle, by sliding the arms in the mortises, and turning the holding-screw K firmly against the arms, and holding the cutters to their desired position.

C is an adjustable table, and upon which the board

from which the head is cut rests. The table C is adjusted higher or lower, to accommodate the size of the heads to be cut, by means of the ears and holding-screws *c c*. The ears being securely attached to the table, and a screw-thread cut therein, the screw is turned up against the head-stocks on either side, when the table is held firmly in place.

*Operation.*

After having adjusted the revolving cutters E to cut the diameter required, adjust the table C to have the proper relation thereto, place the board upon the table, and between the clamp-disks *a' a'*, put the foot upon the treadle *e*, and bear it down, which, through the action of the connecting-levers, forces the clamp-disk firmly against the opposite sides of the board; motion being imparted to the cutters by means of the fast pulleys *b' b'*, place one hand upon treadle I, and bear it down, which will act to throw the upper ends of levers *h h* in contact with the notches of arms *g* and *g'*, thereby moving the hollow shafts *b b*, with the cutter-heads and cutters, toward each other. As the heads of barrels should be cut and beveled more or deeper on the inside than on the out, the horizontal arm *g*, at its end, being inclined, strikes against pin *g''*, which pushes it to one side, and out of contact with inclined lever *h*, and the spring *b<sup>5</sup>* instantly throws the hollow shaft, with its cutter-head, back to its original position, when the cutter-head has cut a sufficient depth into the board which is to be the top or outside of the head, while the hand is steadily kept upon and bearing treadle I still further down, until lever *h* has carried arm *g'* and hollow shaft with the cutter that cuts the inner side of the head, to cut completely through the board. When the hand is released from treadle I, and the other spring *b<sup>5</sup>* operates to force the hollow shaft back to its original position, the foot is taken from the treadle *e*, when spring *d'* causes the rods *a* to retract and open the clamp-disks *a' a'*, and the head that is cut and completed by cutting it more on one side than the other, can be

taken out of the machine, and the board fed along to cut the second, continuing in this manner until the board is cut into finished heads, ready to be put into barrels.

Having thus described my invention,

What I claim, and desire to secure by Letters Patent, is—

1. The treadle or hand-lever I, inclined levers *h h*, notched horizontal arms *g g'*, eye-rings *b<sup>3</sup> b<sup>3</sup>*, in combination with the hollow, revolving, and reciprocating shafts *b b* and cutter-heads D D, having cutters E E, in the manner and for the purpose shown.

2. The treadle or hand-lever I, inclined lever *h*, spring notched arm *g*, with inclined end, pin *g''*, eye-ring *b<sup>3</sup>*, hollow revolving and reciprocating shaft *b*, and cutter-head D, having cutters E, arranged to operate upon the outside of the barrel-head, in combination with the inclined lever *h*, notched and rigid arm *g'*, eye-ring *b<sup>3</sup>*, hollow revolving and reciprocating shaft *b*, and cutter-head D, having cutters E arranged to operate upon the inside of the barrel-head, and cut the same in the manner described.

3. The guide-rods *b<sup>4</sup> b<sup>4</sup>*, having springs *b<sup>5</sup> b<sup>5</sup>*, in combination with the hollow revolving and reciprocating shafts *b b*, and revolving cutter-heads D D and cutters E E, in the manner described.

4. The adjustable table C, in combination with the adjustable revolving cutters E E, in the manner described.

5. The treadle *e*, bar *d*, connecting levers *a' a'*, *a<sup>3</sup> a<sup>3</sup>*, *a<sup>2</sup> a<sup>2</sup>*, in combination with the sliding rods *a a*, and disk-clamps *a' a'*, in the manner and for the purpose described.

6. The herein-described machine for cutting the heads of barrels, when the several parts are combined and arranged to operate in the manner and for the purpose described.

AMOS CUTTER.

Witnesses:

EDM. F. BROWN,  
NEWTON CRAWFORD.