



US00D950415S

(12) **United States Design Patent**  
**Kimoto et al.**

(10) **Patent No.:** **US D950,415 S**

(45) **Date of Patent:** **\*\* May 3, 2022**

(54) **MOTOR VEHICLE**

(71) Applicant: **MAZDA MOTOR CORPORATION**,  
Hiroshima (JP)

(72) Inventors: **Eiji Kimoto**, Hiroshima (JP); **Takeshi Shinohara**, Hiroshima (JP); **Kouhei Kawakami**, Hiroshima (JP); **Young-Joon Suh**, Hiroshima (JP); **Ryosuke Nozaki**, Hiroshima (JP); **Yutaka Sukegawa**, Hiroshima (JP); **Heitetsu Takemoto**, Hiroshima (JP); **Yasuyuki Murata**, Hiroshima (JP)

(73) Assignee: **MAZDA MOTOR CORPORATION**,  
Hiroshima (JP)

(\*\*) Term: **15 Years**

(21) Appl. No.: **29/730,944**

(22) Filed: **Apr. 9, 2020**

(51) **LOC (13) Cl.** ..... **12-08**

(52) **U.S. Cl.**  
USPC ..... **D12/91; D12/92**

(58) **Field of Classification Search**  
USPC ..... D12/86, 90-92, 164; D21/433, 434,  
D21/531-535; 296/181.1-181.5, 183.1  
CPC ..... B62D 25/00; B62D 25/06; B62D 33/00;  
B62D 35/00

See application file for complete search history.

(56) **References Cited**

**U.S. PATENT DOCUMENTS**

D512,000 S *	11/2005	Suzuki	.....	D12/91
D573,063 S *	7/2008	Sawai	.....	D12/92
D649,911 S *	12/2011	Okumoto	.....	D12/92
D690,619 S *	10/2013	Jelec	.....	D12/91
D693,274 S *	11/2013	Tamatani	.....	D12/92
D694,153 S *	11/2013	Takahashi	.....	D12/92
D696,980 S *	1/2014	Miyazawa	.....	D12/92

D697,834 S *	1/2014	Okue	.....	D12/91
D705,700 S *	5/2014	Chen	.....	D12/91
D711,785 S *	8/2014	Tabata	.....	D12/92
D718,661 S *	12/2014	Tabata	.....	D12/91
D731,923 S *	6/2015	Tanaka	.....	D12/91
D735,078 S *	7/2015	Tamiya	.....	D12/91
D741,752 S *	10/2015	Messale	.....	D12/91
D754,031 S *	4/2016	Talsma	.....	D12/91
D755,676 S *	5/2016	Yoshimine	.....	D12/91
D765,546 S *	9/2016	Kimoto	.....	D12/91
D790,404 S *	6/2017	Iwao	.....	D12/92
D819,493 S *	6/2018	Tabata	.....	D12/91
D830,909 S *	10/2018	Lichte	.....	D12/92
D830,910 S *	10/2018	Tamatani	.....	D12/92
D842,760 S *	3/2019	Tsuchida	.....	D12/92
D845,174 S *	4/2019	Iwao	.....	D12/92
D845,835 S *	4/2019	Tsuchida	.....	D12/91

(Continued)

**FOREIGN PATENT DOCUMENTS**

EM 6901336-0001 1/2020

*Primary Examiner* — Melody N Brown

(74) *Attorney, Agent, or Firm* — Studebaker & Brackett PC

(57) **CLAIM**

The ornamental design for a motor vehicle, as shown and described.

**DESCRIPTION**

FIG. 1 is a top, front and left side perspective view of a motor vehicle showing our new design;  
FIG. 2 is a left, front perspective view thereof;  
FIG. 3 is a top, rear and right side perspective view thereof;  
FIG. 4 is a right, rear perspective view thereof;  
FIG. 5 is a front elevational view thereof;  
FIG. 6 is a rear elevational view thereof;  
FIG. 7 is a left side elevational view thereof;  
FIG. 8 is a right side elevational view thereof; and,  
FIG. 9 is a top plan view thereof.

**1 Claim, 8 Drawing Sheets**

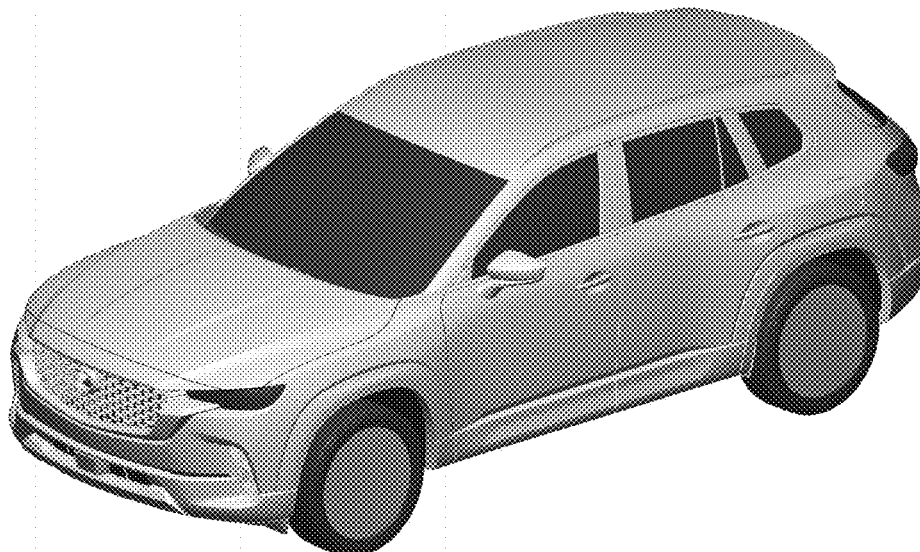

(56)

**References Cited**

U.S. PATENT DOCUMENTS

D859,214	S	*	9/2019	Ahn	.....	D12/91
D879,664	S	*	3/2020	Chen	.....	D12/91
D896,127	S	*	9/2020	Yanagisawa	.....	D12/91
D929,257	S	*	8/2021	Matsuda	.....	D12/91

\* cited by examiner



FIG.1



FIG.2



FIG.3



FIG.4



FIG.5

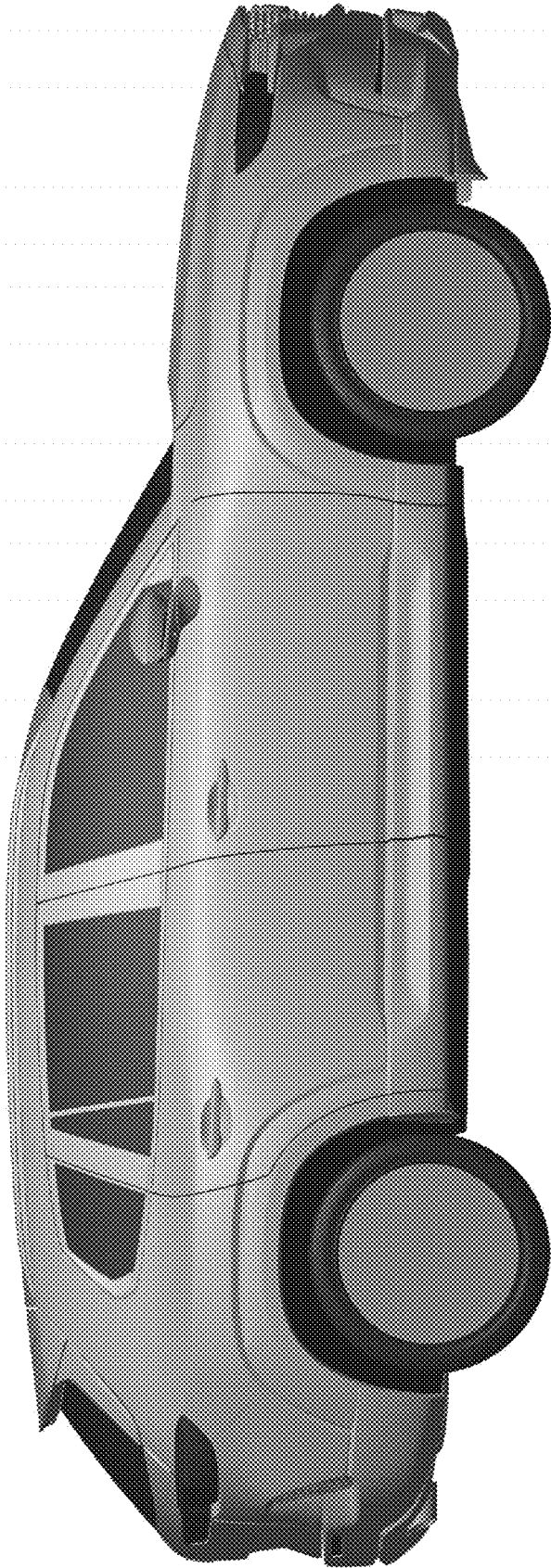

FIG.6



FIG.7

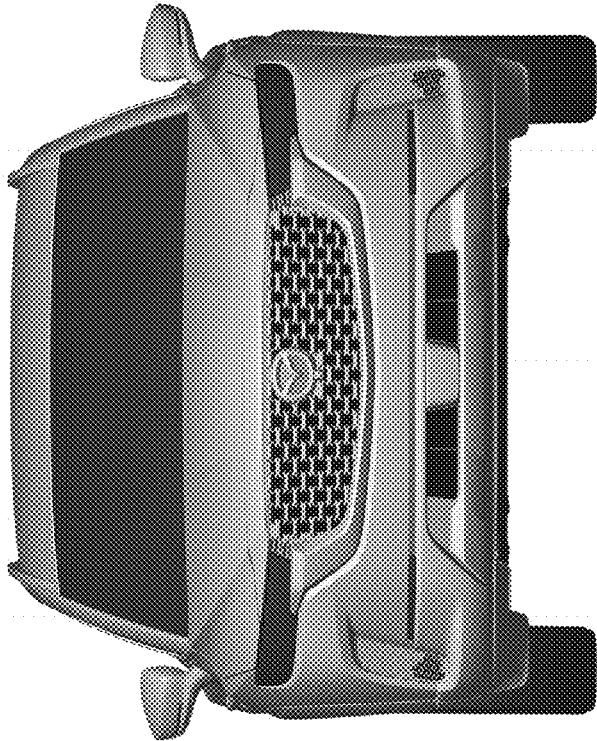

FIG.8

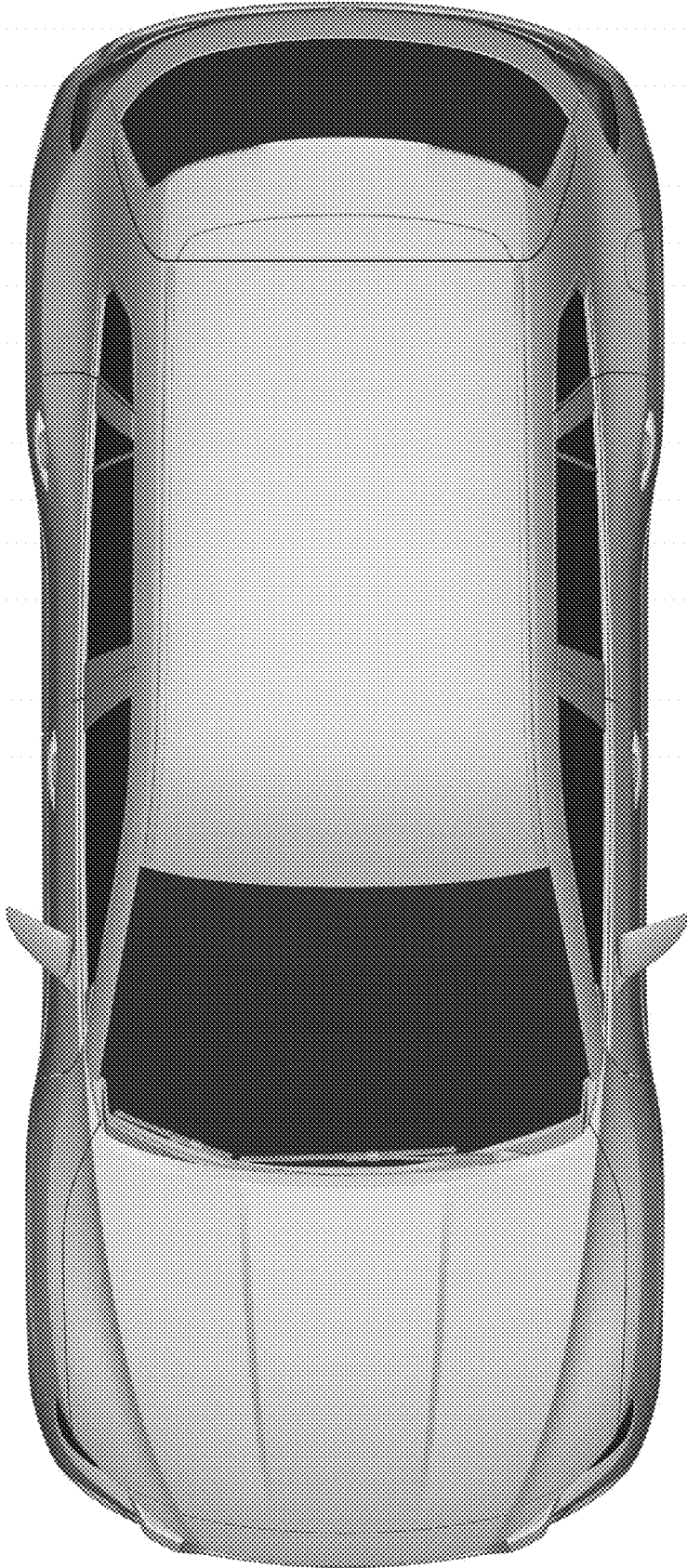

FIG. 9