

R. B. KIRKWOOD.  
MACHINE FOR PRINTING UPON ROUND OBJECTS.

(Application filed July 17, 1900.)

(No Model.)

2 Sheets—Sheet 1

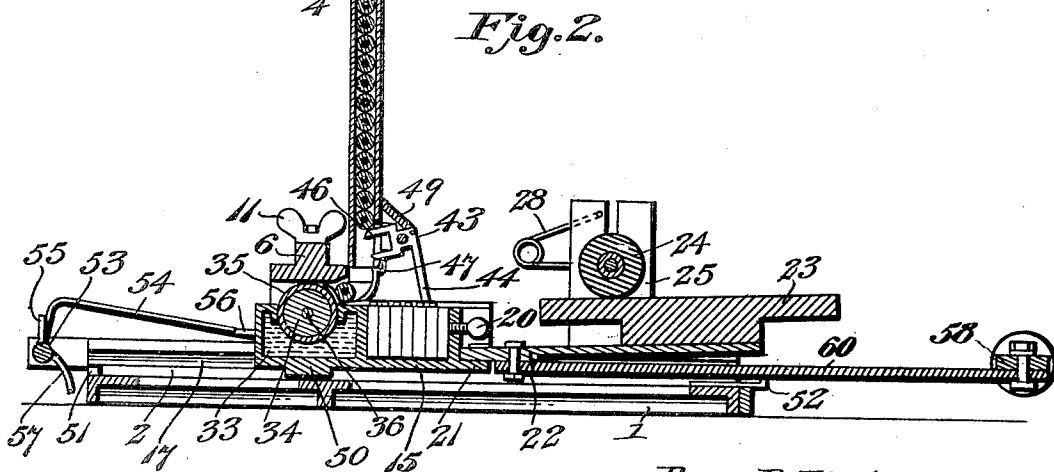
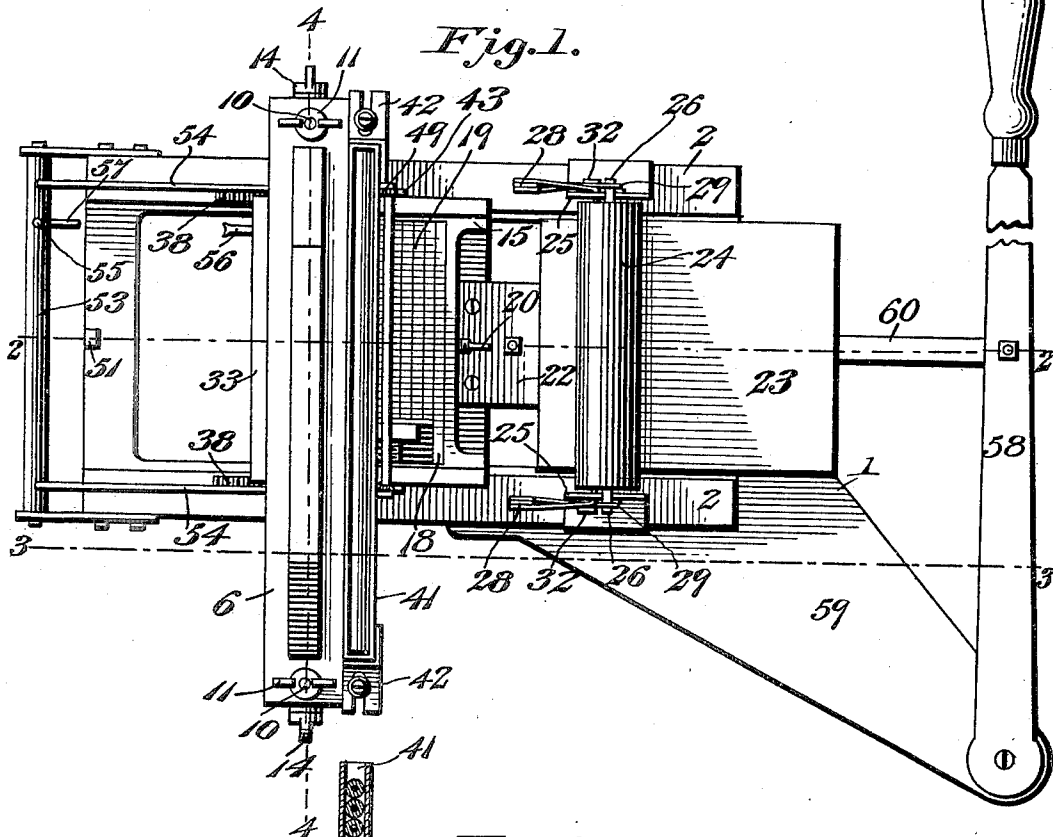

Ross B. Kirkwood  
Inventor

By *E. G. Siggers*  
Attorney

Witnesses  
*Edwin S. McKee*  
*Paul G. Julihn*

R. B. KIRKWOOD.  
MACHINE FOR PRINTING UPON ROUND OBJECTS.

(Application filed July 17, 1900.)

(No Model.)

2 Sheets—Sheet 2.

Fig. 3.

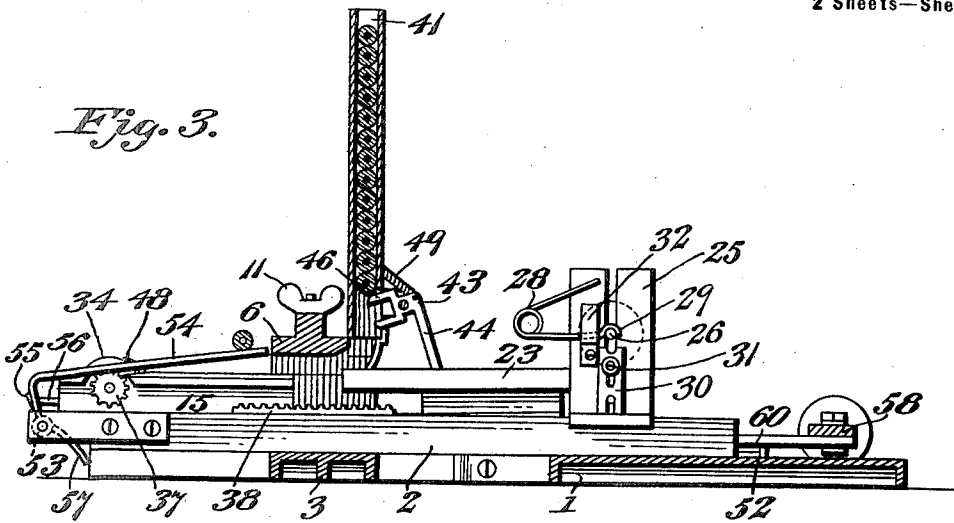

Fig. 4.

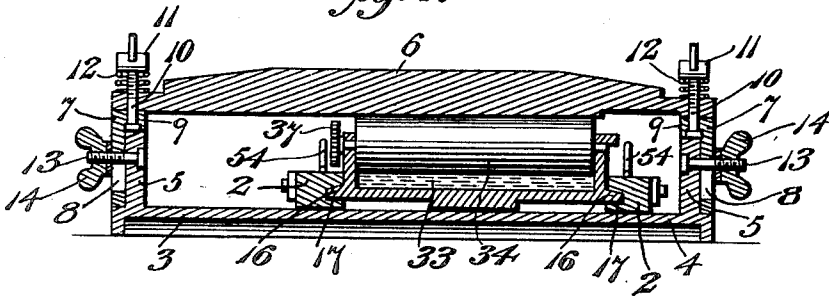

Fig. 5.

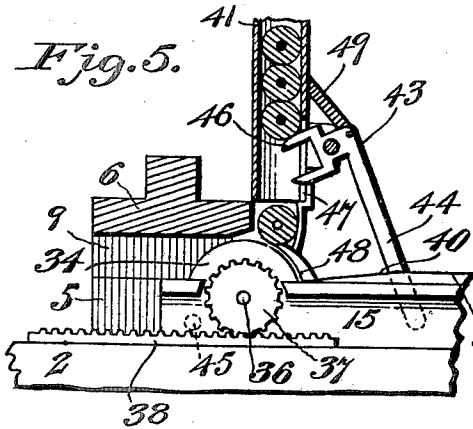
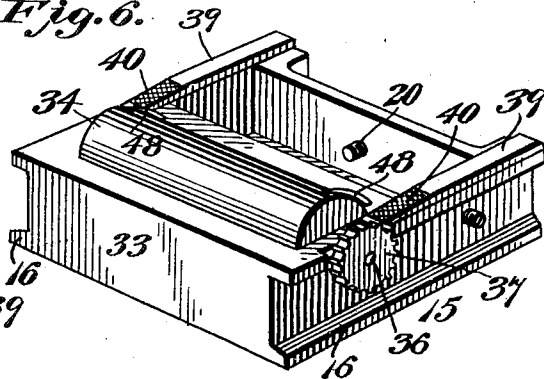

Fig. 6.



Ross B. Kirkwood  
By Inventor

*E. G. Siggers*  
Attorney

Witnesses  
*Edwin H. Mee*  
*Russ C. Julian*

# UNITED STATES PATENT OFFICE.

ROSS B. KIRKWOOD, OF CHATTANOOGA, TENNESSEE.

## MACHINE FOR PRINTING UPON ROUND OBJECTS.

SPECIFICATION forming part of Letters Patent No. 668,104, dated February 12, 1901.

Application filed July 17, 1900. Serial No. 23,941. (No model.)

### *To all whom it may concern:*

Be it known that I, ROSS B. KIRKWOOD, a citizen of the United States, residing at Chattanooga, in the county of Hamilton and State of Tennessee, have invented a new and useful Machine for Printing upon Round Objects, of which the following is a specification.

My present invention relates to a novel machine for imprinting significant, ornamental, or other characters upon round objects, and considered somewhat more specifically it comprehends mechanism for imprinting characters by indentation or otherwise upon the surfaces of lead-pencils or other articles of cylindrical form, the object of the invention being to provide a device by means of which advertising matter, for instance, may be printed upon a large number of lead-pencils or similar objects in a minimum space of time for the purpose of quickly and inexpensively equipping such objects with particular reference for their use as advertising vehicles intended for gratuitous distribution.

To the accomplishment of the object stated and others subordinate thereto, all as will hereinafter more fully appear, the invention consists in mounting a yielding platen above a suitable base in which is slidably mounted a reciprocating type or die chase movable under the platen for the purpose of imprinting by indentation or otherwise upon the surface of lead-pencils or other round or cylindrical objects fed successively to the platen from a magazine and rolled between the platen and the type or dies through the movement of the chase.

The invention further consists in the provision of novel means for delivering the printed objects after they have passed under the platen, and where the device is intended for surface-printing to obtain colored characters it comprehends still further the employment of inking mechanism for the type or dies and wiping mechanism for clearing the surface of the platen of ink before the pencils or other objects are presented thereunder.

The invention further consists in certain details of construction and arrangement, all of which will hereinafter more fully appear as the description of the preferred form of my invention, illustrated in the accompanying drawings, is proceeded with.

In said drawings, Figure 1 is a plan view of my machine complete. Fig. 2 is a central longitudinal sectional view thereof on the line 2 2 of Fig. 1, showing a pencil about to be rolled under the platen by the forward reciprocation of the type-chase. Fig. 3 is a sectional elevation on the line 3 3 of Fig. 1. Fig. 4 is a transverse sectional view on the line 4 4 of Fig. 1. Fig. 5 is a detail sectional view through the platen and the lower end of the magazine and showing the pencil-feeding device and the wiping-roll, together with the actuating mechanism of the latter, in elevation; and Fig. 6 is a detail perspective view, on a somewhat-enlarged scale, of the chase, showing the arrangement of the gripping-flanges, the wiping-roll, and the guards for the latter.

Referring to the numerals of reference employed to designate corresponding parts and structural features throughout the several views, 1 indicates a base or supporting-frame of skeleton form surmounted by tracks or ways 2 and provided at a point intermediate of its length with transverse extensions 3 and 4, terminating beyond the tracks, where said extensions are provided with upstanding plates 5, designed to support a transverse platen 6, extending across the machine at a suitable distance above the tracks 2. For the accommodation of pencils or other objects of various diameters, as will be hereinafter explained, provision must be made for adjusting the platen 6 toward or from the base and for yieldingly retaining the platen in its adjusted positions. To secure the desired adjustment, the platen 6 is directly supported upon adjusting-plates 7, provided with elongated slots 8 and having inturned flanges 9, which latter extend over the upper edges of the plates 5 and receive the platen-retaining bolts 10, which pass upwardly through the opposite ends of the platen and are provided upon their upper ends with thumb-nuts 11, between which and the platen are interposed springs 12, which oppose a yielding resistance to the elevation of the platen. The adjustment of the plates 7 may be secured in any suitable manner, but preferably by the employment of bolts 13, passed transversely through the flanges 5 and through the slots 8 in the plates 7. Beyond the plates these

bolts 13 are provided with compression-nuts 14, which being screwed against the plates 7 retain the latter in their adjusted positions to secure the desired elevation of the platen 6.

5 I wish it to be understood, however, that these details of construction are shown simply for the purpose of disclosing one embodiment of means for adjusting the platen and means for exerting any desired pressure tending to maintain the platen against the pencil or other body as the latter is propelled between the platen and type by the reciprocation of the chase.

15 Mounted for reciprocation upon the base I provide a type-chase 15, having lateral flanges 16, received within opposed grooves 17 in the tracks 2. The chase 15 is designed for the reception of the type-form 18 or other carrier for the type 19 or other forms of imprinting, indenting, or other dies, the type or dies being retained in the chase with their faces projecting thereabove by any suitable securing means—as, for instance, a compression-screw 20, screwed through the rear of the wall of the chase.

25 I have stated that my invention is adapted for the imprinting or impressing of characters either with or without a complementary provision for printing in colors; but inasmuch as the operation of the simplest embodiment of the invention will appear as well from a description of the construction and operation of the more fully developed device I will proceed with a description of the entire structure, contemplating the employment of inking and other supplementary devices, before proceeding with a description of the operation, whereby the pencils or other round objects are fed to the machine and are propelled between the faces of the type or dies and the yielding platen 6. To the rear end of the base 21 of the chase 15 is secured in any suitable manner a rearwardly-extending supporting-plate 22, upon which is fixed the inking-plate 23. The ink or other coloring-matter is distributed over the plate 23 in the ordinary manner and is intended to be taken up by an idle inking-roller 24, yieldingly supported between a pair of brackets 25, up-  
50 standing from and fixed to the tracks 2 or other fixed parts of the base.

One embodiment of the means for yieldingly supporting the roller 24 comprehends the extension of terminal roller-trunnions 26 through vertical slots 27 in the brackets 25 and the employment of springs 28, secured at one end to the brackets and having their other ends 29 hooked over the trunnions 26 to exert sufficient pressure upon the inking-roller to insure its proper contact with the inking-plate 23 without preventing such vertical yielding of the roller as may be necessary to the proper operation of the device. For the purpose of adjusting the normal position of the roller 24 I mount upon each bracket 25 a bearing-plate 30, having its upper edge notched for the reception of the

roller-trunnions and provided with an adjusting-screw 31 for the purpose of retaining the plate in any desired position to prevent the gravitation of the roller below any predetermined point. Where this particular form of roller-mounting is employed, keepers 32 are also mounted upon the brackets 25 for the purpose of properly positioning the springs 28.

It will now appear that the reciprocation of the type-chase will first effect the presentation of the inking-plate 23 to the inking-roller 24 for the purpose of evenly distributing the ink over the surface of the latter and that continued movement of the chase in the same direction will cause the type to be carried into contact with the inking-roller, which will distribute the ink over the faces of the type or other dies preparatory to the presentation of the type below the platen 6.

Where the complementary inking apparatus is employed—that is to say, where the printing is not a mere matter of indentation, but necessitates the application of ink to the objects printed upon—it is evident that the under face of the platen 6 will be more or less soiled by contact with the printed characters, and it therefore becomes necessary to wipe the ink from the platen before the successive presentations of the objects thereto. A simple form of platen-wiping mechanism is comprehended by a receptacle 33 at the front end of the chase 15 for the reception of benzine or other cleaning fluid. Mounted to have its periphery immersed in the benzine or other liquid and to project sufficiently above the receptacle for contact with the platen is a wiping-roll 34, either constructed of or covered by an absorbent material 35, designed as the chase is reciprocated to be wiped across the face of the platen for the purpose of removing the ink therefrom. This wiping action must be positive, however—that is to say, it must be something more than the mere idle contact of the roller with the soiled surface—and I therefore prefer to extend the shaft 36 of the wiping-roll 34 beyond one side of the chase for the reception of a pinion 37, designed to mesh with a rack 38, formed upon any suitable part of the device, but preferably upon one of the tracks 2, as shown. This form of gearing will upon the reciprocation of the chase effect the rotation of the wiping-roll in the direction of the arrow in Fig. 5 or in a direction opposite to the direction of rotation of an idle roller in contact with the platen.

The pencils are designed to be placed upon the chase either by hand or by mechanical feeding appliances and to be rolled between the platen and the faces of the type or dies by the forward movement of the chase. In order to prevent the upwardly-projecting faces of the type from striking edgewise against the pencils and to insure the exertion of a proper pressure upon the pencil by the platen before the type are presented to the former, the chase is provided at opposite sides

with what may be termed "gripping-flanges" 39, preferably formed of hard rubber or other frictional material having inclined approaches 40 in advance of the type and upon which the pencils are deposited to be urged up said inclines and upon the flanges as the type are advanced to a position under the platen. The upper faces of the gripping-flanges 39 are located in a plane slightly below the plane of the type-faces, so that as the pencil is rolled forward while tightly gripped between the platen and the gripping-flanges the faces of the type will be presented to the surface of the pencil for the purpose of imprinting thereon or impressing therein the ornamental or significant characters desired. It will be evident from a consideration of this operation that the arrangement of the characters imprinted upon the round objects may be varied between wide limits. For instance, if the type are arranged, as shown in Fig. 1 of the drawings, in parallel rows extending across the chase the corresponding characters will be arranged upon the pencil or other object in parallel rows arranged in circumferential series thereon. If, on the contrary, the characters are arranged in inclined rows disposed diagonally across the chase, the arrangement of the characters imprinted upon the object will be of spiral form, and many other variations of arrangement of unique and attractive character may in like manner be effected to enhance the value of the articles as advertising devices by simple rearrangements of the type or dies within the chase.

While the supply of pencils or other objects to the machine by hand is productive of good results, I prefer to employ a magazine designed to contain a large number of pencils and automatic feeding mechanism operated—as, for instance, by the reciprocation of the chase—to deposit the pencils successively in proper position to be printed and subsequently discharged as the chase is reciprocated under the impulse of suitable actuating mechanism. The present embodiment of the magazine comprehends the employment of a long narrow chamber 41 of any suitable height and arranged with its lower edge immediately behind the platen and in the horizontal plane of the upper surface thereof. The casing is preferably retained by horizontally-adjustable magazine-supporting brackets 42, mounted upon the adjusting-plates 7 and designed to be adjusted to accommodate magazines of varying sizes in order that the machine may be employed for the imprinting of objects having widely-varying dimensions. Both the upper and lower ends of the magazine 41 are preferably open, and at the lower or discharge end is provided suitable feed-regulating mechanism, the illustrated embodiment of which comprises a pair of pivoted feed-levers 43, having depending trip ends 44, located in the paths of trip-lugs 45, projecting from the side of the chase and

formed at their upper ends with escapements 46, extending into the magazine through vertical slots 47 and designed to permit the pencils to be fed one at a time to the chase as the inclined projections 40 of the gripping-flanges 39 are presented under the magazine.

In Fig. 5 of the drawings one of these feed-regulating levers is shown as having been tripped to cause one of the pencils to be dropped, the latter being shown as resting upon the guards 48 of the wiping-roll 34, which guards are provided to prevent the pencils from coming into contact with the roll. Further forward movement of the chase will permit the released pencils to gravitate from the guards 48 to the inclined approaches 40, as shown in Fig. 2 of the drawings, in which figure the pencil is shown as being about to be rolled between the gripping-flanges and the platen. Each of the levers 43 is retained by a spring 49 in the position shown in Fig. 5 of the drawings—that is to say, with the load of pencils supported above the escapement 46. This form of mounting permits the chase to be retracted without actuating the escapements, since the lugs 45 will strike the lower ends of the trip-levers 44, which latter will yield to permit the passage of the lugs. The presentation of the lugs 45 to the levers 44 from the opposite direction—that is to say, when the chase is moved forward—will, on the contrary, swing the lower ends of the feed-levers to permit the lowest pencil in the magazine to drop into the escapement, and as soon as the lug has passed the spring 49 will return the lever to its normal position to deposit the pencil from the escapement to the chase and to prevent the escape of the remaining portion of the load. For the purpose of limiting the movement of the chase in opposite directions the latter is provided with a stop 50 upon its bottom, designed to strike against buffers 51 and 52, provided at the opposite ends of the base within the path of movement of the stop.

For the purpose of discharging or delivering the printed articles from the machine I provide beyond the forward end of the base a transverse rock-shaft 53, having a pair of angular pencil-discharging arms 54, extending rearwardly above the tracks 2 at opposite sides of the chase and designed normally to lie below the surface of the latter. As the chase reaches the end of its movement and liberates a pencil from under the platen the pencil delivering or discharge arms 54 are designed to be elevated by the vibration of the rock-shaft 53 for the purpose of providing an incline down which the pencil may roll from the machine, or, if desired, the vibration of the shaft may be sufficient to cause the arms 54 to strike the pencil a light blow sufficient to throw it into a receptacle provided for its reception beyond the end of the machine. For the purpose of vibrating the rock-shaft the latter may be provided with a radial pin 55, designed to be struck by the end of a tap-

pet projection 56, extending forwardly from the end of the chase and designed to rock the shaft 53 until the movement of the latter is stopped by the contact of a stop-pin 57, carried by the shaft, with the front of the bed or other fixed part.

While I contemplate the employment of various forms of actuating mechanism for the reciprocation of the chase in machines designed for various uses, I have shown a simple form of operating means comprehending an operating-lever 58, pivoted at one end upon an extended bearing-lug 59, projecting from the bed and having a pivotal connection through a pitman 60 with the support 22 of the inking-plate.

The passage of the pencils to a position under the platen is facilitated by beveling the rear edge of the latter, as indicated in Fig. 5, and pencils with projecting surfaces—as, for instance, metal rubber-holders or the like—are accommodated by recessing the under face of the platen, as indicated in Fig. 4 of the drawings.

Briefly the operation of my device is as follows: The parts being in the position indicated in Fig. 1, the retraction of the chase will cause the type to be inked by the roller 24, which latter has already received a coating of ink from the inking-plate 23, reciprocated beneath it. During the inking of the type the wiping-roll 34 has been carried across the under face of the platen 6 for the purpose of clearing the latter from any ink which may have accumulated thereon during the previous printing operation. The chase is now reciprocated in the opposite direction until the lugs 45 strike the ends of the arms 44 of the feed-levers for the purpose of rocking the latter against the resistance of the springs 49 to permit one of the pencils to be received within the escapements 46. Continued movement of the chase will cause the lugs 45 to pass the arms 44, permitting the springs 49 to restore the escapements to their original positions and the release of the pencil retained therein. The released pencil will then drop upon the guards 48 of the wiping-roll and will pass from thence to the inclined approaches 40 of the gripping-flanges. The movement of the chase will now cause the pencil to be wedged under the platen, and the latter will yield against the resistance of the springs 12 to permit the pencil to be firmly held between the platen and the faces of the type or dies. The relative movement of the type with respect to the platen will now cause the pencil to be rotated or rolled to present its entire surface for the presentation of the type, and as the chase advances sufficiently to release the pencil from under the platen the operation of printing will have been completed and the tappet projection 56 will strike the pin 55, vibrating the shaft 53 and causing the arms 54 to be elevated for the reception and discharge of the pencil, as shown in Fig. 3 of the drawings.

What I claim is—

1. In a machine for printing round objects, the combination with a reciprocatory chase, of a platen in coöperative relation with said chase, said platen being retained against movement except in a direction transverse to the direction of the movement of the chase. 70
2. In a machine for printing round objects, the combination with a reciprocatory chase, of a platen retained against movement in the direction of movement of the chase, means for adjusting the platen toward or from the chase, and means for opposing a yielding resistance to the movement of the platen beyond the positions to which it is adjusted. 80
3. In a machine for printing round objects, the combination with a base and a reciprocatory chase, of adjustable supports carried by the base, a platen carried by said supports in operative relation to the chase, and means for retaining the platen upon the adjustable supports in a manner to permit the platen to yield beyond its adjusted positions. 90
4. In a machine for printing round objects, the combination with a base and a reciprocatory chase, of supporting-plates adjustably carried by the base beyond the opposite sides of the chase, means for movably retaining the platen upon the adjusting-plates, and means for opposing a yielding resistance to the movement of the platen relative to said plates. 95
5. In a machine for printing round objects, the combination with a platen and a reciprocatory chase, of delivering mechanism located beyond the platen to receive and deliver the printed objects and means for actuating said mechanism to remove the objects from the chase. 100
6. In a machine for printing round objects, the combination with a platen and a reciprocatory chase, of a delivering device designed to deliver the printed objects from the machine, and means for actuating the delivering device through the movement of the chase. 110
7. In a printing-machine, the combination with a platen and a reciprocatory chase, of a delivering device normally disposed below the surface of the chase, and means for moving said device to a position above the chase for the purpose of removing the printed objects from the latter. 115
8. In a machine for printing round objects, the combination with a platen and a reciprocatory chase, of a pair of oscillating delivery-arms located beyond the platen, and means for oscillating said arms to effect their engagement with the printed objects to lift them from the chase. 120
9. In a machine for printing round objects, the combination with a platen and a reciprocatory chase, of a pair of oscillatory delivering-arms located to remove the printed objects from the chase, and means for effecting the actuation of said arms through the movement of the chase. 130
10. In a machine for printing round objects, the combination with a platen and a reciprocatory chase, of a pair of oscillatory delivering-arms located to remove the printed objects from the chase, and means for effecting the actuation of said arms through the movement of the chase. 130

catory chase, of a rock-shaft, a delivering device operated through the movement of the rock-shaft to deliver the printed objects from the machine, and mechanism for vibrating the rock-shaft through the movement of the chase.

11. In a machine for printing round objects, the combination with a platen and a reciprocatory chase, of a rock-shaft located beyond the platen and having a pair of delivery-arms designed to be normally disposed below the surface of the chase and to be elevated above the chase to effect the removal of the printed objects therefrom, a pin extending from the rock-shaft, and a tappet projection extending from the chase and moving in a path obstructed by said pin.

12. In a machine for printing round objects, the combination with a reciprocatory chase and a platen, of gripping devices carried by the chase and designed to cooperate with the platen to effectually grip the object to be printed, for the protection of the dies carried by the chase.

13. In a machine for printing round objects, the combination with a platen and a reciprocatory chase, of guide-flanges extending from the chase and designed to cooperate with the platen to grip a round object and to cause said object to roll as the type or dies carried by the chase are advanced.

14. In a machine for printing round objects, the combination with a platen and a reciprocatory chase, and gripping-flanges carried by the chase and provided with inclined approaches.

15. In a machine for printing round objects, the combination with a platen having a plain face and a reciprocatory chase, of means for depositing the objects upon the chase for presentation under the platen.

16. In a machine for printing round objects, the combination with a plain-faced platen and a reciprocatory chase, of feed mechanism operated through the movement of the chase to deposit the objects to be printed upon said chase for presentation therewith under the platen.

17. In a machine for printing round objects, the combination with a platen and a reciprocatory chase, of a magazine for the reception of the objects to be printed, means for delivering said objects one at a time to the chase, and means carried by the chase for advancing the objects under the platen.

18. In a machine for printing round objects, the combination with a platen and a reciprocatory chase, of a magazine for the reception of the objects to be printed, feed mechanism for delivering said objects to the chase, and gripping-flanges carried by said chase and having inclined approaches designed to insure the presentation of the objects under the platen through the movement of the chase.

19. In a machine for printing round objects, the combination with a platen and a reciprocatory chase, of feed mechanism and deliv-

ering mechanism located at opposite sides of the platen and designed, respectively, to feed the objects to be printed to the chase and to remove said objects therefrom for delivery from the machine.

20. In a machine for printing round objects; the combination with a platen and a reciprocatory chase, of feed mechanism and delivering mechanism located, respectively, in advance of the platen and beyond the same, and means for operating said feed and delivering mechanisms through the movement of the chase.

21. In a machine for printing round objects, the combination with a platen and a reciprocatory chase, of a magazine located to deliver the objects to be printed to the surface of the chase, a feed-lever provided with an escapement extending into the magazine, and means movable with the chase for effecting the actuation of the feed-lever.

22. In a machine for printing round objects, the combination with a platen and a reciprocatory chase, said chase being provided with inclined gripping devices, of means located directly at the rear edge of the platen for delivering the objects to be printed to the chase as the inclined gripping devices are moved under the platen.

23. In a machine for printing round objects, the combination with a platen and a reciprocatory chase, of feed mechanism located immediately in advance of the platen, delivering devices arranged to remove the printed objects from the chase at a point beyond the platen, and means for operating said device through the movement of the chase.

24. In a machine for printing round objects, the combination with a platen and a reciprocatory chase, of inking mechanism, and means operated by the chase for wiping the platen after each printing operation.

25. In a machine for printing round objects, the combination with a platen and reciprocatory chase, of inking mechanism, and a wiping-roll carried by the chase and designed to be presented to the face of the platen after each printing operation.

26. In a machine for printing round objects, the combination with a platen and a reciprocatory chase, of inking mechanism, a wiping-roll carried by the chase, and means for operating the wiping-roll to cause that portion of its periphery in contact with the platen, to move in the direction of movement of the chase.

27. In a machine for printing round objects, the combination with a base and a platen carried thereby, of a reciprocatory chase, inking mechanism therefor, a wiping-roll carried by the chase, a pinion movable with said wiping-roll, and a rack mounted upon the base and designed to engage the pinion.

28. In a machine for printing round objects, the combination with a platen, of a reciprocatory chase, an inking-plate and a wiping-roll carried at opposite ends of the chase and

movable therewith, and an inking-roll designed to be presented successively to the inking-plate and chase through the reciprocation of said chase.

5 29. In a machine for printing round objects, the combination with a base, a platen carried thereby and a reciprocatory chase, of feed mechanism located in advance of the platen, delivering mechanism located beyond the  
10 platen, means for operating the feed mechanism and delivering mechanism through the

movement of the chase, inking mechanism, and a platen-wiper, said wiper being carried by the chase for presentation to the platen after each printing operation.

In testimony that I claim the foregoing as my own I have hereto affixed my signature in the presence of two witnesses.

ROSS B. KIRKWOOD.

Witnesses:

JOHN H. SIGGERS,  
FLORENCE E. WALTER.