



(12) APPLICATION

(11) 20201224

(13) A1

NORWAY

(19) NO

(51) Int Cl.

B65D 1/00 (2006.01)

B65D 1/22 (2006.01)

B65D 1/40 (2006.01)

B65D 1/42 (2006.01)

B65D 1/44 (2006.01)

B65D 1/46 (2006.01)

B65D 43/00 (2006.01)

B65D 43/02 (2006.01)

B65D 81/18 (2006.01)

B65D 81/38 (2006.01)

B65D 85/50 (2006.01)

Norwegian Industrial Property Office

(21)	Application nr	20201224	(86)	Int. application day and application nr	2018.04.20 PCT/CL2018/050020
(22)	Application day	2020.11.12	(85)	Entry into national phase	2020.11.12
(24)	Date from which the industrial right has effect	2018.04.20	(30)	Priority	
(41)	Available to the public	2020.11.12			
(71)	Applicant	ENVASES CHILOE S.A., Ruta 5 sur km 1009, Parcelación La Laja S/N, PUERTO VARAS, Chile			
(72)	Inventor	Pablo Ignacio GRIFFEROS REYES, Américo Vespucio Norte 1125, Huechuraba, SANTIAGO, Chile			
(74)	Agent or Attorney	ACAPO AS, Postboks 1880 Nordnes, 5817 BERGEN, Norge			

(54) Title STORAGE AND TRANSPORT BOX
(57) Abstract

The present invention relates to a wall-lid reinforcement system for the reinforcement of a box for storing and/or transporting goods wherein the box comprises a base body formed by side walls and a bottom wall, each one comprising inner and outer faces wherein the inner faces define an inner space with an opening; and a lid with an inner face, an outer face and a peripheral edge to close the opening of the base body and to define a closed configuration of the box. The wall-lid reinforcement system comprises at least one wall reinforcement body arranged on at least one face of at least one side wall of the base body of the box wherein said wall reinforcement body comprises a wall support area arranged towards the opening of the base body; and at least one lid reinforcement body arranged on the inner face of the lid, wherein the lid reinforcement body comprises a lid support area that faces the wall support area when the box is closed; wherein the wall reinforcement body and the lid reinforcement body define at least one reinforcement assembly. Furthermore, the invention relates to a box for storage and/or transport of goods.

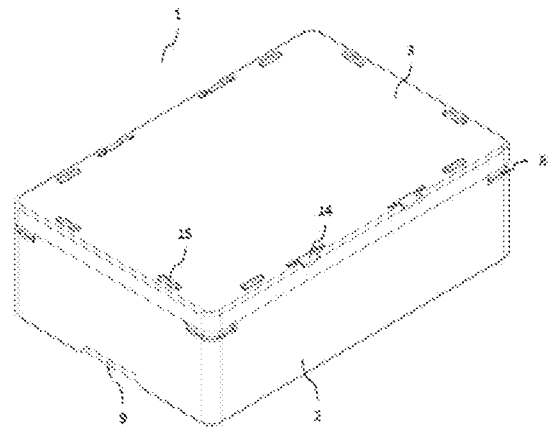

STORAGE AND TRANSPORT BOX

SPECIFICATION

5 The present invention relates to a reinforcement system for storage and/or transport boxes, particularly for reinforcing the connection between the wall and the lid of said box. Furthermore, the invention relates to a storage and transport box which incorporates said reinforcement system, particularly in boxes with thermal insulation of the interior space for the storage and/or transport of food that require special storage conditions, for example, storage and/or transport of fish.

10

BACKGROUND

Currently there are various solutions aimed at boxes for the storage and/or transport of fresh food, which require special storage conditions, for example, to avoid losing the cold chain.

As a general rule, boxes for storing and/or transporting this type of food have a base body and a lid,
15 both rigid components made of a material that favors the thermal insulation of the inside of the box. For example, the most widely used storage and transport boxes in the industry are made of expanded polystyrene (EPS), since this material is inexpensive, it facilitates the manufacturing process, is light and has a low coefficient of thermal conductivity which for densities between 12 to 30 gr/l it ranges from 0.030 to 0.045 W/(mK), providing good thermal insulation properties at low weight.

20 Although storage and/or transport boxes made of EPS are the most used in the industry, said boxes have several disadvantages mainly derived from the low mechanical resistance of the material with which they are manufactured, mainly against bending stresses which usually result in the box faces breaking due to impacts during handling whether on the sides, bottom and/or lid. In addition, resistance to compression stresses in EPS boxes is mainly due to the use of high-density EPS and the
25 management of wall thickness, an issue that limits the potential for reducing the weight of current boxes.

5 Therefore, the need arises for a box that maintains the advantages of the current boxes used by the industry mainly with regard to thermal insulation and resistance to compression but improving impact resistance and reducing the weight of the box.

In the prior art there are various solutions that claim to obtain an optimal combination of benefits improving resistance, optimizing weight, providing thermal insulation according to storage
10 requirements, lid sealing to avoid liquid leakage and other advantages associated with the storage and transport of food with cold chain. For example, GB 2337044 discloses a box for the storage and transport of fish comprising a base body and a lid arranged to provide a closure that reduces leakage of liquid from inside the box, for example from melting ice. To this end, the base body of the box comprises an edge with a projection and the lid comprises an edge with a groove arranged to receive
15 said projection establishing a pressure connection between body and lid. Furthermore, the box in GB 2337044 comprises elements intended to favor the stacking of boxes for transport. In this context, although document GB 2337044 defines optimal sealing and stacking qualities for an EPS box, it does not propose improvements to prevent breakage by impact of the box face (s) nor does it seek to reduce weight of the same.

20 On the other hand, document WO 2011/062502 discloses an EPS box for food transport wherein one of the objectives is to achieve a good combination of low weight and lower exterior volume while maintaining the same interior volume. To this end, the box in WO 2011/062502 replaces the EPS lid with a thin film which would maintain sealing properties and, considering the transport of stacked boxes, it would not significantly affect the thermal insulation properties taking advantage of the
25 insulation provided by the upper case in contact with the thin film of the lower case. In this context, although document WO 2011/062502 seeks to reduce the weight of the EPS box the approach used in said document considerably reduces the thermal insulation performance, particularly when the boxes are not in stacked format.

Finally, document FR 2286068 defines an EPS box of which base has perpendicular sides with
30 internal reinforcing projections on which the lid rests in its closed position. Although it is expected that the internal reinforcements in the walls of the box disclosed in FR 2286068 improve the mechanical resistance of the box, said document does not disclose an integral solution that seeks to increase resistance and at the same time to reduce the weight of the box. Furthermore, in FR 2286068 it is established that the cover rests on the internal reinforcement projections without

5 considering a special mechanism aimed at communicating the forces exerted on the cover, such as compression towards said reinforcement projections.

Considering the above, it is necessary to have a reinforcement system and a box that solve the problems presented by the prior art, particularly providing greater impact resistance and reducing the weight of the box.

10

DESCRIPTION OF THE INVENTION

An objective of the present invention is to solve the problems existing in current boxes for storage and/or transport of goods, preferably food, said boxes being preferably made of a material that favors thermal insulation, such as EPS.

15 Another objective of the present invention is to provide a reinforcement system to be implemented in a box, particularly between at least one wall and the lid increasing the resistance to bending and/or damage by impacts on the faces of the box.

Another objective of the present invention is to provide a box that incorporates the reinforcement system, preferably integrated in the same material of the box which favors the reduction of the weight of the box compared to current solutions.

20 Another objective of the invention is to provide a box made of EPS for the storage and/or transport of fish, preferably salmon, which favors thermal insulation, control of the fluids inside the box, resistance to bending and/or impacts, resistance to compression and weight reduction compared to current boxes, integrating the reinforcement system of the present invention.

25 In order to meet the above objectives, the present invention proposes a wall-lid reinforcement system for reinforcing a storage and/or transport box of goods wherein the box comprises:

a base body formed by side walls and a bottom wall, each one comprising interior and exterior faces wherein the interior faces define an interior space with an opening; and

30 a lid with an inner face, an outer face and a peripheral edge to close the opening of the base body and to define a closed configuration of the box.

The wall-lid reinforcement system for the box with the above elements comprises:

5 at least one wall reinforcing body arranged on at least one face of at least one side wall of the base body of the box wherein said wall reinforcing body comprises a wall supporting area arranged towards the opening of the base body; and

at least one lid reinforcing body arranged on the inside face of the lid wherein the lid reinforcing body comprises a lid support area that faces the wall support area when the box is closed;

10 wherein the wall reinforcement body and the lid reinforcement body define at least one reinforcement assembly.

The objective of the reinforcement assembly is to provide a resistant element that not only allows to obtain an adequate resistance to compression that can be exerted on the box during use, but also seeks to avoid the damage that the box receives mainly on its lateral, upper and lower faces, because
15 of impacts or its manipulation, a question that usually results in the breaking of the affected face considering the low resistance to bending that the material usually used in this type of boxes has.

According to one embodiment, the wall reinforcing body is arranged on the inner face of at least one side wall of the base body and the lid reinforcing body is arranged towards the inside of the peripheral edge of the lid. In this way, it is possible to maintain the outer volume of the box that
20 affects the stacking and storage conditions of the boxes according to the needs of the industry, achieving a balance between resistance and maintenance of the inner volume of the box which is affected in a way that is not meaningful to the interests of the industry. Notwithstanding this, as an alternative the present invention contemplates that the reinforcement assembly is arranged towards the exterior of the peripheral edge of the box.

25 According to one embodiment, the wall reinforcement body and/or the lid reinforcement body have a curved surface wherein preferably the edges of the curved surface of the wall reinforcement body and/or the lid reinforcement body are arranged tangentially to the wall and/or lid, respectively. Through this configuration a smooth interior finish is achieved which prevents the undesired waste accumulation inside the box and facilitates cleaning. Furthermore, the internal configuration of the
30 box seeks to avoid damage to the stored goods and to increase the rigidity of the side faces.

According to another embodiment, the reinforcement system comprises at least one reinforcement assembly arranged on each side wall of the box wherein reinforcement assemblies on opposite side walls of the box can be arranged facing each other, forming a pair of opposite reinforcement

5 assemblies. According to an alternative embodiment, the reinforcement system comprises an upper reinforcement element for each pair of opposite reinforcement assemblies, wherein said upper reinforcement element joins said opposite reinforcement assemblies and wherein said upper reinforcement element is arranged on the inner face of the lid. This configuration allows a compressive integration of the different reinforcing elements that the system has, forming an arrangement of reinforcing elements that cooperate to allow the resistance of the box to be maintained at a lower weight. Notwithstanding the foregoing, it is relevant to note that the invention also contemplates the alternative that each reinforcing element operates independently, in effect, according to an embodiment the reinforcing system comprises at least one reinforcing element arranged on the inner face of the lid, joining opposite portions of the peripheral edge of the lid not necessarily being related to a wall-lid reinforcement assembly.

10 Within this context, each upper reinforcing element can be configured as an arched profile beam, with a wider cross section towards the peripheral edge of the lid. This configuration seeks to increase the bending resistance of the lid and to better integrate the reinforcement elements in the lid with the wall-lid reinforcement assemblies. In addition, this configuration protects the lid against impacts and compression.

20 According to an alternative embodiment, each lid reinforcing body projects outward the inner face of the lid entering the opening of the base body in the closed configuration of the box. Through this configuration it is sought that the lid reinforcement body, in addition to increasing the strength of the lid-wall joint, facilitates the fitting of the lid into the base body when the box is configured in its closed state.

30 According to a preferred embodiment of the invention, the wall support area and the lid support area facing said wall support area, are at least partially in contact. By means of said contact the reinforcement components in the lid communicate with the reinforcement components in the base body, generating a continuous reinforcement body in a closed configuration. According to this embodiment, the strength of the box is substantially improved.

According to another embodiment of the invention the wall reinforcement body and the lid reinforcement body are arranged substantially vertically. In this way, the resistance provided by the reinforcement body and the material necessary to make it, are optimized. In this context, it should be noted that a preferred embodiment of the invention contemplates that the reinforcement system is

5 integrated into the box and it is made of the same material of the box. Preferably, also the material of the box is selected from the group consisting of materials that promote thermal insulation, preferably the material is expanded polystyrene (EPS).

On the other hand, as stated above, the present invention also relates to a box for the storage and/or transport of goods, comprising:

10 a base body formed by side walls and a bottom wall, each one comprising interior and exterior faces wherein the interior faces define an interior space with an opening; and

a lid with an inner face, an outer face and a peripheral edge to close the opening of the base body and define a closed configuration of the box.

Said box is configured to additionally comprise a wall-lid reinforcement system according to the
15 qualities and characteristics described above.

According to one embodiment of the box, the opening of the base body comprises a perimeter edge with a first connection means and the inner face of the lid comprises a perimeter edge with a second connection means, said first and second connection means being complementary to each other. Preferably, the first connecting means corresponds to a connecting edge projecting up from the
20 opening and the second connecting means corresponds to a connecting groove arranged to receive the connecting edge.

On the other hand, the inner face of the bottom of the base body of the box may comprise an arrangement of grooves particularly arranged for the accumulation of fluids inside the box either as a result of the melting of a cooling medium such as ice or from the stored goods. According to an
25 embodiment, the grooves allow storage of at least 88 cc of fluid separating it from the stored goods. Said grooves also favor thermal damping, improving thermal insulation performance of the case.

According to another embodiment of the box, the outer face of the bottom of the base body comprises a configuration of recesses and stacking grooves wherein said stacking grooves are configured to receive stacking projections arranged on the outer face of the lid. In this regard, the
30 recesses on the bottom outer face of the base body make it possible to substantially reduce the weight of the box and, at the same time, increase the resistance of the bottom of the box against impacts. Furthermore, the arrangement of the recesses is designed to avoid substantially affecting the thermal insulation properties. On the other hand, the arrangement of stacking grooves on the

5 outer face of the bottom of the box and of stacking projections on the outer face of the lid which
interact cooperatively during stacking, makes it possible not only to favor the regular stacking of the
box one on top of the other in the same direction, thus avoiding relative lateral displacement
between stacked boxes, but rather it favors cross-stacking or substantially orthogonal stacking
between boxes, usually used when transporting this type of boxes wherein a first level is arranged
10 with boxes in a first direction and a second level is arranged with the boxes in a second direction
substantially orthogonal to the first direction of the boxes on the first level.

According to another embodiment, the base body comprises four side walls, two major side walls
and two minor side walls wherein the wall-lid reinforcement system comprises at least one
reinforcement assembly arranged on each minor side wall and at least two reinforcement assemblies
15 arranged on each major side wall. Through this configuration, it is sought to have an adequate
number of reinforcement assemblies on each face of the box wherein the major lateral faces could
have more than one reinforcement assembly. In this context, we must emphasize that the
reinforcement assemblies not only seek to favor compression resistance but also seek to avoid the
breakage of the faces caused by blows or manipulation, due to the low resistance to bending of the
20 material usually used.

According to the above embodiment, a reinforcement assembly on the minor side wall can be
arranged at $1/2$ the length of the minor side wall and two reinforcement assemblies on the major side
wall can be arranged at $1/3$ and $2/3$ of the length of the major lateral wall. Other configurations of
reinforcement assemblies are also encompassed by the present application particularly with regard
25 to the major side wall, for example comprising three reinforcement assemblies located $1/4$, $1/2$ and
 $3/4$ the length of the major lateral wall or $1/3$, $1/2$ and $2/3$ the length of the major lateral wall.

On the other hand, according to alternative embodiments of the invention, the base body can
comprise vertical perforations towards the corners of the base body generating a vertical space in the
corners which seeks to reduce the weight of the box by removing material without sacrificing
30 resistance and thermal insulation capacity. These perforations can be substantially cylindrical,
generated for example by corresponding modifications in the mold during the manufacturing of the
box.

According to one embodiment, the base body comprises at least one corner recess arranged towards
the upper corners of the base body defining an area for removal of the lid when it is in a closed

5 configuration. The corner recess allows the exposed edge of the lid to be grasped with ease, in order to facilitate lid removal when in closed configuration.

According to one embodiment of the invention, the base body comprises at least one lateral recess arranged on the outer face of at least one lateral wall defining a surface for a label. This configuration allows any labeling to be placed on one or more of the side faces of the box or even on
10 the lid, in an area specially designed for the label which has a minimum recess that prevents damage to the labels by contact, protecting them with the general wrapping of the box.

Furthermore, the base body comprises at least one lower recess arranged on the outer face of at least two side walls towards the bottom of the base body defining a gripping surface. Preferably, the lower grip recess is provided on the opposite side walls of the box.

15 On the other hand, the outer face of the lid comprises clamping zones arranged towards the peripheral edge of the lid. Preferably, said clamping zones are in a position aligned with each lid reinforcing body. The clamping zone corresponds to an indication on the lid of the box which is intended for the implementation of straps, winches or tightening bands that are used to keep the lids closed, exerting compression between the lid and the base body. Usually the implementation of said
20 bands or straps is carried out in any area of the box damaging the box when said area is not sufficiently resistant to the stresses implied by the implementation of the closure bands. Additionally, considering that the implementation of the straps is carried out on the production line after closing the box and when they already contain the goods to be stored and/or transported, any damage resulting from the application of the straps which results in making it impossible the use of
25 the box, generates a delay in the production line due to the replacement of the box in question.

In this sense, the tightening zone contemplated by the invention provides a clear indication to the operator about the zone where each strap must be applied wherein said zone, being aligned with the reinforcing bodies, is configured to resist the tightening force exerted by the strap and avoids the damages caused by it on the box, at least those that require its replacement, making it impossible to
30 use.

According to a preferred embodiment of the invention, the box is made of a material selected from the group of materials that favors thermal insulation preferably the material is expanded polystyrene (EPS). Moreover, the density of the material is less than 23.7 gr/l and greater than 16.7 gr/l, more

5 preferably approximately 18.6 gr/l, considering variations of +- 10% as a result of the manufacturing process.

On the other hand, the thickness of the side walls of the base body is between 20 and 40 mm, preferably between 23 and 37 mm and the thickness of the lid is between 18 and 30 mm, preferably between 20 and 27 mm. Furthermore, the thickness of the bottom of the base body is between 20
10 and 30 mm, preferably it is 26 mm. Based on this configuration, the weight of the box is less than 420 grs, preferably 365 grs. In addition, the compressive strength of the box is at least 602 kg, equaling or even improving on current boxes which reach compression loads of around 600 kg, but substantially reducing the overall weight of the empty box which usually is over 450 grs. All this while maintaining a minimum variation in terms of thermal insulation equating the thermal
15 performance of current boxes.

Finally, it is relevant to highlight that the box in question serves for thermal insulation of the interior space of the base body, preferably for the storage and/or transport of food that requires maintaining a cold chain and/or being kept fresh towards the destination, for example, any type of marine food such as fish. Indeed, one embodiment of the box is specially designed for storing salmon.

20

BRIEF DESCRIPTION OF THE FIGURES

As a part of the present invention, the following representative figures of the same are presented teaching preferred embodiments of the invention and therefore they should not be considered as limiting the definition of the claimed matter.

25 Figures 1A and 1B show top and bottom perspective views of the box in its closed configuration, respectively.

Figures 2A and 2B show top perspective views of the base body of the box showing different embodiments of the interior of the box.

Figure 2C shows a top plan view of the base body of the box identifying cut line D-D.

30 Figure 2D shows the cutting section D-D corresponding to the base body of Figure 2C.

Figures 2E and 2F show side views of the base body of the box from the smaller side and the larger side, respectively, identifying cutting lines B-B and C-C.

5 Figures 2G and 2H show cutting sections B-B and C-C, respectively, corresponding to the base body of Figure 2F.

Figure 2I shows a bottom plan view of the base body of the box.

Figure 3A shows a bottom perspective view of the lid of the box.

Figure 3B shows a top plan view of the lid of the box, identifying the cutting line E-E.

10 Figure 3C shows the cutting section E-E corresponding to the lid of Figure 3B.

Figure 3D shows a side view of the lid of the box identifying the cutting line F-F.

Figure 3E shows the cutting section F-F corresponding to the lid of Figure 3D.

Figure 3F shows a bottom plan view of the lid of the box.

15 DETAILED DESCRIPTION OF AN EMBODIMENT

Figures 1A and 1B show a preferred embodiment of the box 1 in its closed configuration wherein the lid 3 is arranged covering the opening of the base body 2, closing the box 1.

Figures 2A to 2I show different views and sections of the base body 2 identifying its characteristic elements according to the exemplified embodiment.

20 Figures 3A to 3F show different views and sections of the lid 3 identifying its characteristic elements according to the exemplified embodiment.

Figure 2A shows an embodiment of the base body 2 comprising at least one wall reinforcing body 4 arranged on at least one face of at least one side wall of the base body 2 of the box 1 wherein said reinforcing body wall 4 comprises a wall support zone 5 arranged towards the opening of the base
 25 body 2. Furthermore, in Figure 2A it is shown that the opening of the base body 2 comprises a perimeter edge with a first connection means 10 corresponding to a connecting edge projecting upward from the opening. Furthermore, in Figure 2A it can be seen that the inner face of the bottom of the base body 2 comprises an arrangement of grooves 6 to receive fluids inside the box 1. On the other hand, in Figure 2A it can be seen that the base body 2 comprises, according to one
 30 embodiment, vertical perforations 7 towards the four corners of the base body 2, corner recesses 8

5 arranged towards the upper corners of the base body 2 and at least one lower recess arranged on the outer face of the base body 2 towards the bottom thereof, defining a gripping surface 9.

In Figure 2B an alternative embodiment of the arrangement of grooves 6' can be seen, according to an alternative embodiment of the invention.

Figure 2C shows a plan view of the base body, showing the arrangement of grooves 6 according to the preferred embodiment. In addition, the arrangement of the vertical perforations 7 of the first connection means 10 and the configuration of the wall reinforcing bodies, especially of the wall support zones 5 that are arranged in the base body 2, are evident.

In Figure 2D a section of the base body 2 is shown, according to the cut line D-D in Figure 2C. Figure 2D shows the projected configuration of the first connection means 10, the gripping surfaces 9 and the depth of the grooves 6. Moreover, Figure 2D shows the recess 12 that the outer face of the bottom of the base body 2 has, as well as the stacking groove 11 arranged towards the periphery of the outer face of the bottom of the base body 2, and the depth of the label surface 13 on two of the faces of the base body 2.

Figures 2E and 2F show side views of the base body 2 identifying the minor side of the base body in Figure 2E and the major side of the base body in Figure 2F. In both figures the first connection means 10 of the base body 2 can be seen as well as the corner recesses 8 that said body has. Furthermore, in Figure 2E the label surface 13 can be seen.

Figures 2G and 2H show cross-sectional areas of the base body 2 shown in Figure 2F, both sections according to lines B-B and C-C of Figure 2F. By comparing both cutting sections it can be seen that both represent the depth of the grooves 6, the recess 12 and the stacking grooves 11, as well as the projection of the first connecting means 10 which configures a connecting edge. Additionally, when comparing the cutting sections in Figures 2G and 2H it is possible to notice that at different distances from the major side of the base body 2, the cross sections vary according to the elements present at said distances. For example, in Figure 2B, section B-B crosses the wall reinforcing bodies 4 which is identified by the greater thickness of the wall of the base body in said section B-B. On the other hand, Figure 2H shows section C-C wherein the cut crosses an area that does not comprise a wall reinforcing body identifying a smaller thickness of the wall in said section. On the other hand, it is also appreciated that the section C-C comprises additional stacking grooves 11' arranged towards the center of the section.

5 Figure 2I shows in more detail the different elements or characteristics of the outer face of the bottom of the base body 2, showing the spatial arrangement of the recess 12 and of the stacking grooves 11 and 11' wherein the first corresponds to a groove that runs the entire perimeter of the base body 2 and the second corresponds to four grooves, two of them arranged towards each minor lateral end of the base body 2. Furthermore, it is shown that the center of the box in its lower part,
10 also has stacking grooves 11'' arranged in a portion of the outer face of the bottom that does not include recess 12.

On the other hand, Figure 3A shows a perspective view of the lid 3 of the box being possible to appreciate the arrangement of the lid reinforcement bodies 4' and the lid support areas 5' which are arranged in addition to the wall reinforcement bodies 4 and wall reinforcement zones 5 according to
15 the preferred embodiment. Moreover, Figure 3A shows the arrangement of the second connection means 10' of the lid complementing the first connection means 10 of the base body, the reinforcement elements 13 arranged on the inside face of the lid 3 and the arrangement of the clamping zones 14 on the outer face thereof.

Figure 3B shows a top plan view of the lid 3 showing its outer face. This Figure shows the spatial
20 configuration of the clamping zones 14 and of the stacking projections 15 that the lid 3 has, the latter complementary to the stacking grooves 11, 11' and 11'' that the outer face of the bottom of the base body 2 has.

Figure 3C shows section E-E corresponding to the cut of the lines E-E in Figure 3B. In Figure 3C it is possible to see the arrangement of the second connection means 10' in the lid as a peripheral
25 groove that surrounds the perimeter edge of the lid 3. Furthermore, it is possible to appreciate the arrangement of reinforcing elements 13 and the arrangement of the body of the lid reinforcement 4' as an outward projection of the inner face of the lid, entering the opening of the base body 2 in the closed configuration of the box 1.

In Figure 3D a lateral face of the lid 3 can be seen, showing the cut line F-F. Furthermore, Figure 3D
30 shows the lid reinforcement bodies 4', the reinforcement elements 13, the clamping zones 14 and the stacking projections 15, all of which are elements of the lid 3. In this Figure it can be seen that the clamping zones 14 are aligned with the lid reinforcement bodies 4', reinforcing the clamping zone where the straps are placed during the packaging of the boxes.

5 Figure 3E shows section F-F of Figure 3D, wherein a cut of the lid 3 is characterized, with which the beam shape with an arched profile of the reinforcing elements 13 is evidenced, wherein said reinforcing element 13 has a wider cross section towards the peripheral edge of the lid.

Figure 3F shows a bottom plan view of the lid 3, showing its inner face. In said Figure it is possible to see the second connection means 10' as a connection groove that surrounds the entire edge of the lid 3. Furthermore, it can be seen that the configuration of reinforcing elements comprises at least one longitudinal reinforcing element 13' and at least two cross sectional reinforcing elements 13", all of them joining opposite lid support zones 5'.

15 According to the embodiment illustrated in the Figures of the present invention the wall reinforcement bodies 4 and the lid reinforcement bodies 4' comprise a curved surface, resulting in a configuration of undulating interior walls inside the base body 2 as seen in Figures 2A to 2C and on the inner face of the lid 3 as seen in Figure 3F. Additionally, this configuration provides a configuration of walls that have a variable cross section, as shown in Figures 2G and 2H, a configuration that makes it possible to reinforce the box and at the same time to reduce the loss of interior volume.

CLAIMS

1. A wall-lid reinforcement system for the reinforcement of a storage and/or transport box of goods wherein the box comprises:

a base body formed by side walls and a bottom wall, each one comprising interior and exterior faces wherein the interior faces define an interior space with an opening; and

a lid with an inner face, an outer face and a peripheral edge to close the opening of the base body and to define a closed configuration of the box;

the wall-lid reinforcement system characterized in that it comprises:

at least one wall reinforcing body arranged on at least one face of at least one side wall of the base body of the box, wherein said wall reinforcing body comprises a wall supporting area arranged towards the opening of the base body; and

at least one lid reinforcing body arranged on the inner face of the lid, wherein the lid reinforcing body comprises a lid support area that faces the wall support area when the box is closed;

wherein the wall reinforcement body and the lid reinforcement body define at least one reinforcement assembly.

2. The wall-lid reinforcement system according to claim 1, characterized in that the wall reinforcement body is arranged on the inner face of at least one side wall of the base body and in that the lid reinforcement body is arranged towards inside the peripheral edge of the lid.

3. The wall-lid reinforcement system according to any one of claims 1 and 2, characterized in that the wall reinforcement body and/or the lid reinforcement body have a curved surface.

4. The wall-lid reinforcement system according to claim 3, characterized in that the edges of the curved surface of the wall reinforcement body and/or the lid reinforcement body are arranged tangentially to the wall and/or lid, respectively.

5. The wall-lid reinforcement system according to any one of claims 1 to 4, characterized in that it comprises at least one reinforcement assembly arranged on each side wall of the box.

6. The wall-lid reinforcement system according to claim 5, characterized in that reinforcement assemblies on opposite side walls of the box are arranged facing each other, forming a pair of opposite reinforcement assemblies.

7. The wall-lid reinforcement system according to any one of claims 1 to 6, characterized in that it comprises at least one reinforcement element arranged on the inner face of the lid, joining opposite portions of the peripheral edge of the lid.

8. The wall-lid reinforcement system according to claim 6, characterized in that it comprises an upper reinforcement element for each pair of opposite reinforcement assemblies wherein said upper reinforcement element joins said opposite reinforcement assemblies and wherein said upper reinforcing element is arranged on the inner face of the lid.

9. The wall-lid reinforcement system according to any one of claims 6 to 8, characterized in that each upper reinforcement element is configured as an arched profile beam with a wider cross section towards the peripheral edge of the top.

10. The wall-lid reinforcement system according to any one of claims 1 to 9, characterized in that each lid reinforcement body projects outward the inner face of the lid, entering the opening of the base body in the closed box configuration.

11. The wall-lid reinforcement system according to any one of claims 1 to 10, characterized in that the wall support zone and the lid support zone facing said wall support zone are at least partially contacted.

12. The wall-lid reinforcement system according to any one of claims 1 to 11, characterized in that the wall reinforcement body and the lid reinforcement body are arranged substantially vertically.

13. The wall-lid reinforcement system according to any one of claims 1 to 12, characterized in that it is integrated into the box, made of the same material of the box.

14. The wall-lid reinforcement system according to claim 13, characterized in that the material is selected from the group formed by materials that favor thermal insulation, preferably the material is expanded polystyrene (EPS).

15. A box for the storage and/or transport of goods, comprising:

a base body formed by side walls and a bottom wall, each one comprising interior and exterior faces wherein the interior faces define an interior space with an opening; and

a lid with an inner face, an outer face and a peripheral edge to close the opening of the base body and to define a closed configuration of the box;

characterized in that it also comprises a wall-lid reinforcement system according to any one of claims 1 to 14.

16. The box according to claim 15, characterized in that the opening of the base body comprises a perimeter edge with a first connection means and in that the inner face of the lid comprises a perimeter edge with a second connection means, said first and second means of connection being complementary to each other.

17. The box according to claim 16, wherein the first connecting means corresponds to a connecting edge projecting upward the opening and wherein the second connecting means corresponds to a connecting groove arranged to receive the connecting edge.

18. The box according to any one of claims 15 to 17, characterized in that the inner face of the base body bottom comprises an arrangement of grooves.

19. The box according to any one of claims 15 to 18, characterized in that the outer face of the base body bottom comprises a configuration of stacking recesses and grooves, wherein said stacking grooves are configured to receive stacking projections arranged on the exterior face of the lid.

20. The box according to any one of claims 15 to 19, characterized in that the base body comprises four side walls, two major side walls and two minor side walls wherein the wall-lid reinforcement system comprises at least one reinforcement assembly arranged in each minor side wall and at least two reinforcement assemblies arranged in each major side wall.

21. The box according to claim 20, characterized in that a reinforcement assembly on the minor side wall is arranged at $1/2$ the length of the minor side wall and in that two reinforcement assemblies

on the major side wall are arranged $1/3$ and $2/3$ of the length of the major side wall.

22. The box according to claim 20, characterized in that a reinforcement assembly on the minor side wall is arranged at $1/2$ the length of the minor side wall and in that three reinforcement assemblies on the major side wall are arranged $1/3$, $1/2$ and $2/3$ of the length of the major side wall.

23. The box according to claim 20, characterized in that a reinforcement assembly on the minor side wall is arranged at $1/2$ the length of the minor side wall and in that three reinforcement assemblies on the major side wall are arranged $1/4$, $1/2$ and $3/4$ the length of the major side wall.

24. The box according to any one of claims 15 to 23, characterized in that the base body comprises vertical perforations towards the corners of the base body.

25. The box according to any one of claims 15 to 24, characterized in that the base body comprises at least one corner recess arranged

towards the upper corners of the base body defining an area for removal of the lid when it is in the closed configuration.

26. The box according to any one of claims 15 to 25, characterized in that the base body comprises at least one lateral recess arranged on the outer face of at least one side wall defining a surface for a label.

27. The box according to any one of claims 15 to 26, characterized in that the base body comprises at least one lower recess arranged on the outer face of at least two side walls towards the bottom of the base body defining a gripping surface.

28. The box according to any one of claims 15 to 27, characterized in that the outer face of the lid comprises clamping zones arranged towards the peripheral edge of the lid.

29. The box according to claim 28, characterized in that the clamping zones are in a position aligned with each lid reinforcement body.

30. The box according to any one of claims 15 to 29, characterized in that it is made of a material selected from the group of materials favoring thermal insulation, preferably the material is expanded polystyrene (EPS).

31. The box according to any one of claims 15 to 30, characterized in that the density of the material is less than 23.7 g/l and greater than 16.7 g/l, more preferably approximately 18.6 g/l.

32. The box according to any one of claims 15 to 31, characterized in that the thickness of the side walls of the base body is between 20 and 40 mm, preferably between 23 and 37 mm because the thickness of the lid is between 18 and 30 mm, preferably between 20 and 27 mm.

33. The box according to any one of claims 15 to 32, characterized in that the thickness of the base body bottom is between 20 and 30 mm, preferably it is 26 mm.

34. The box according to any one of claims 15 to 33, characterized in that the weight of the box is less than 420 gr, preferably 365 gr.

35. The box according to any one of claims 15 to 34, characterized in that its resistance to compression is at least 602 kg.

36. Use of a box according to any one of claims 15 to 35, characterized in that it serves for thermal insulation of the interior space of the base body.

37. The use according to claim 36, characterized in that it also serves for the storage and/or transport of food.

38. The use according to claim 37, characterized in that the food is fish, preferably salmon.

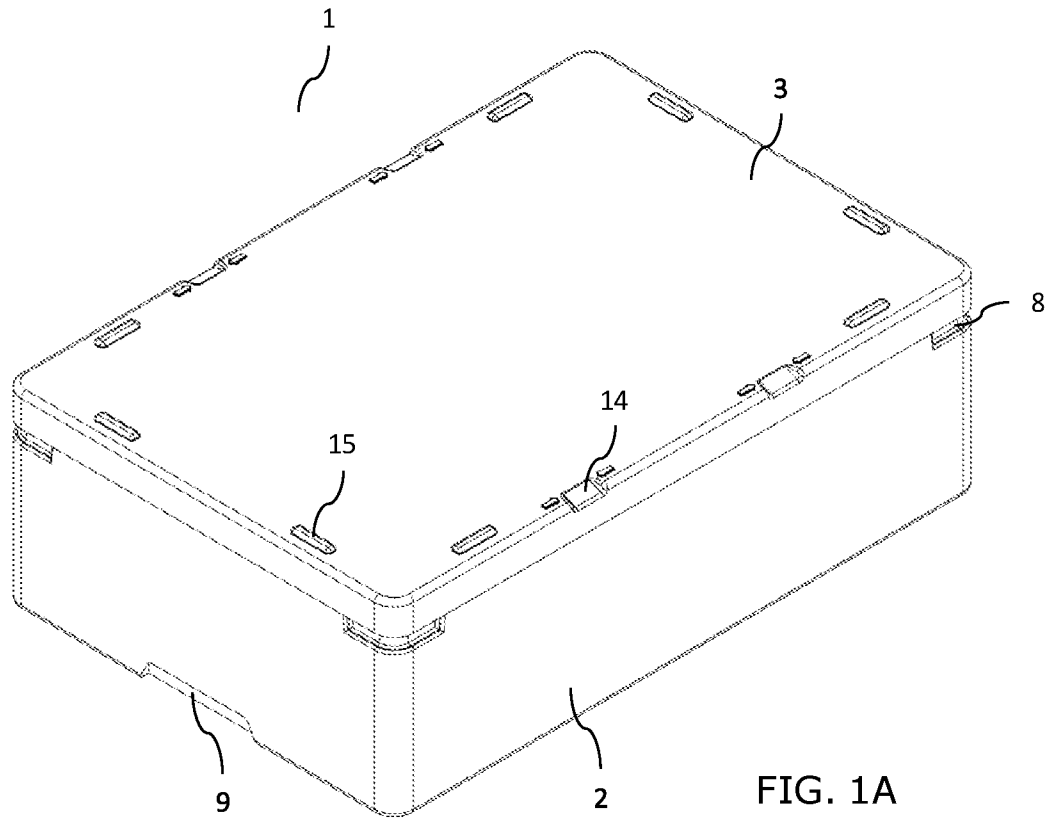

FIG. 1A

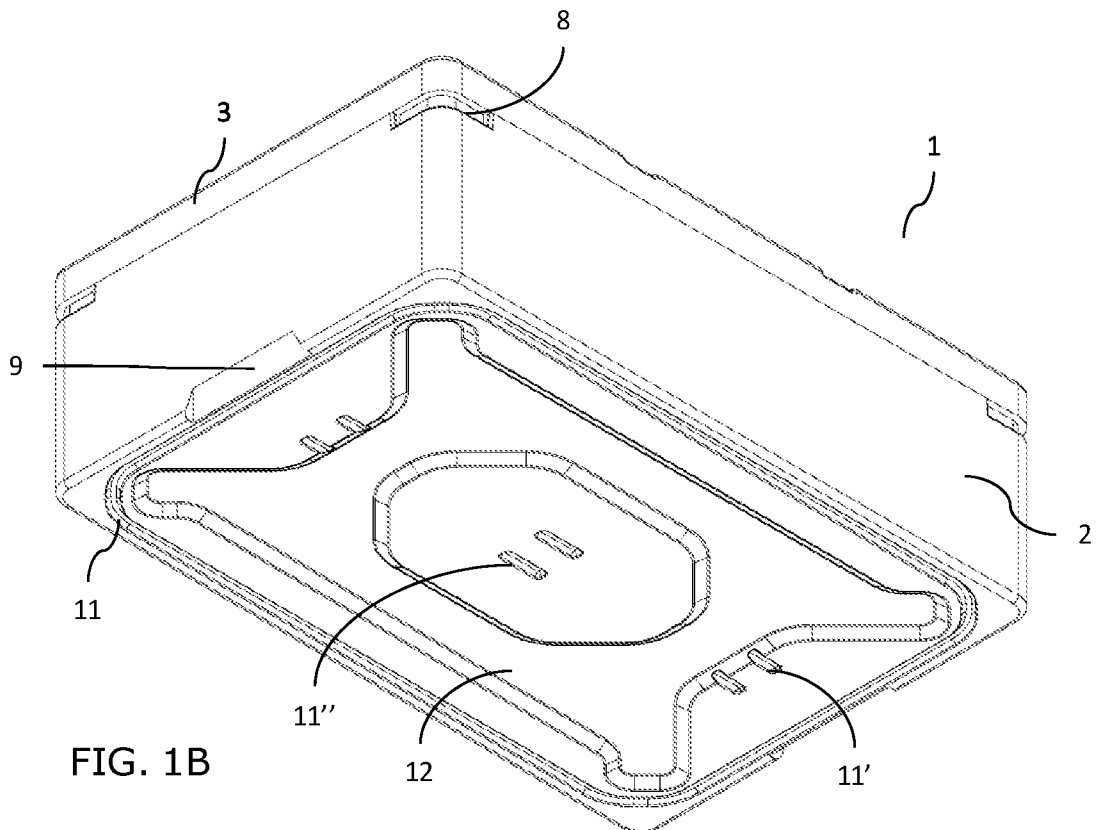

FIG. 1B

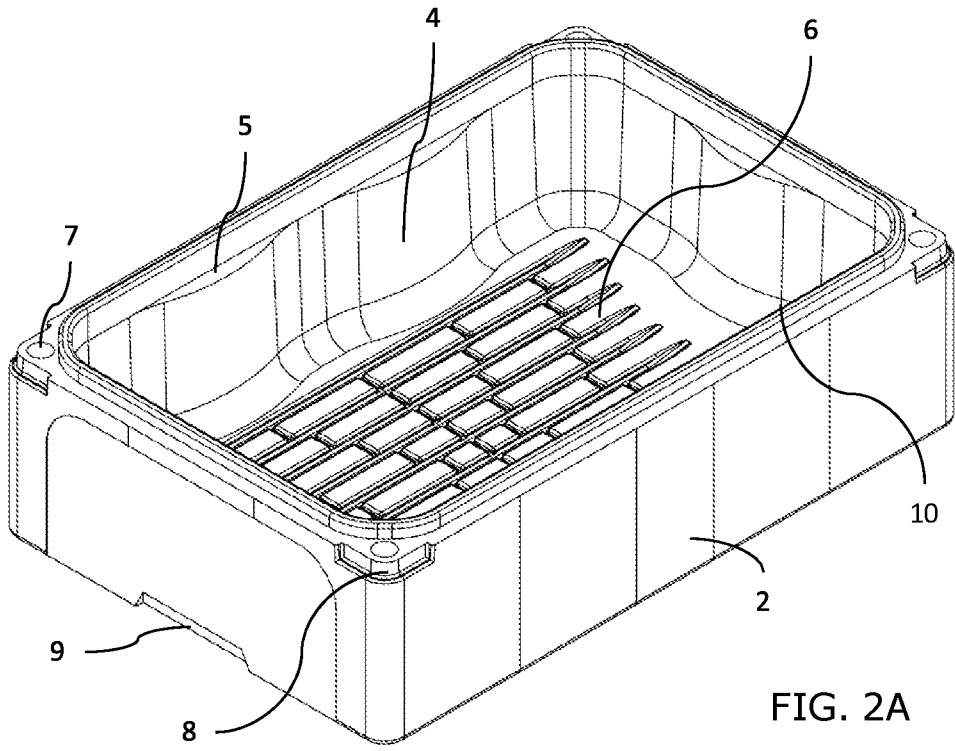

FIG. 2A

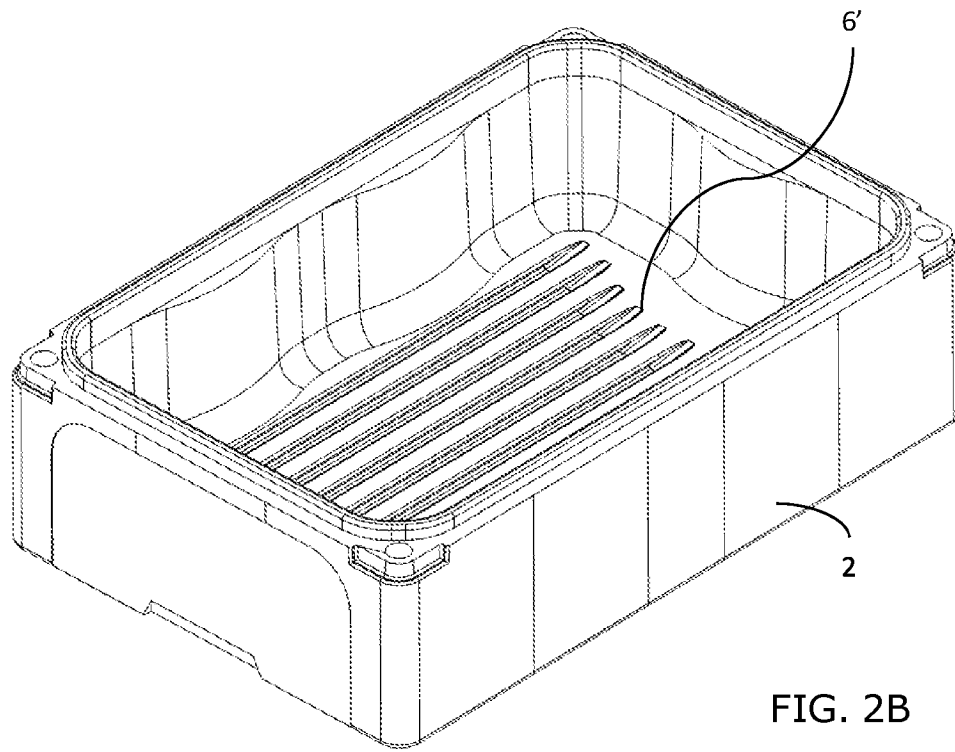

FIG. 2B

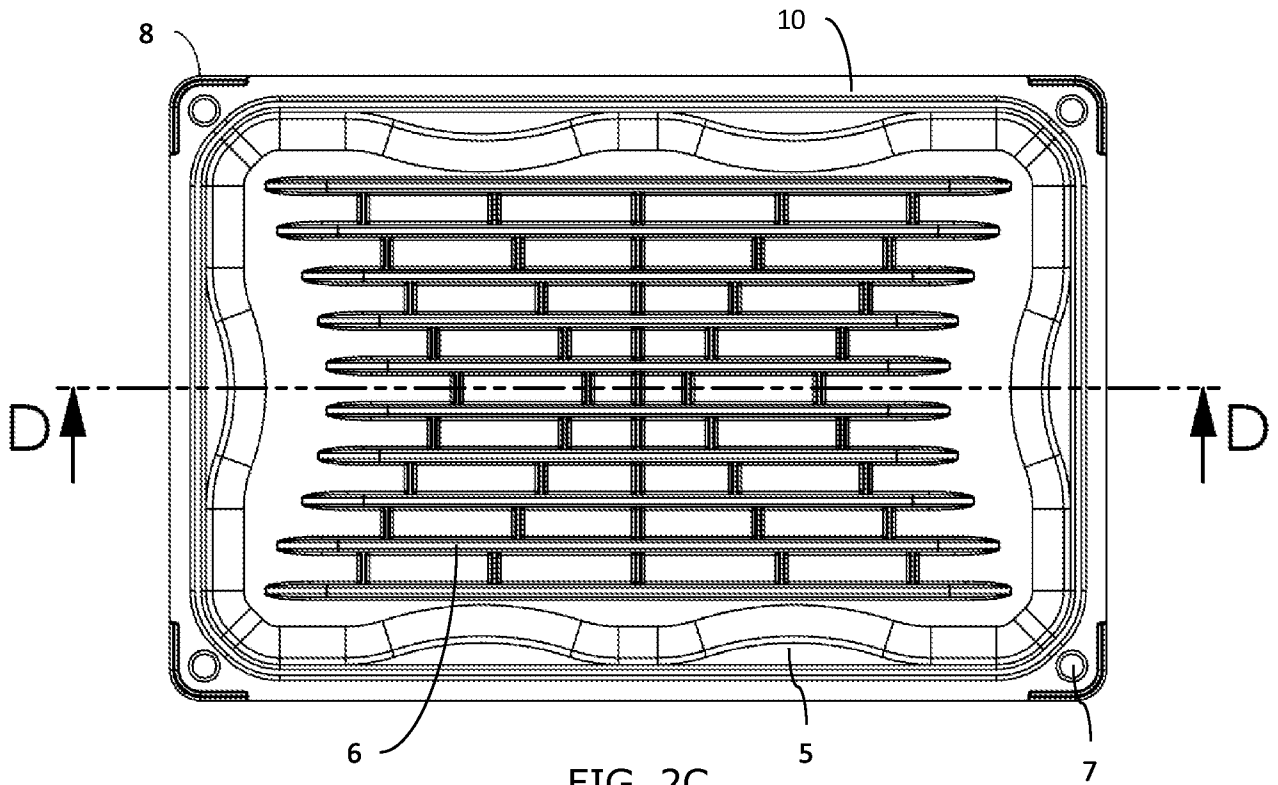
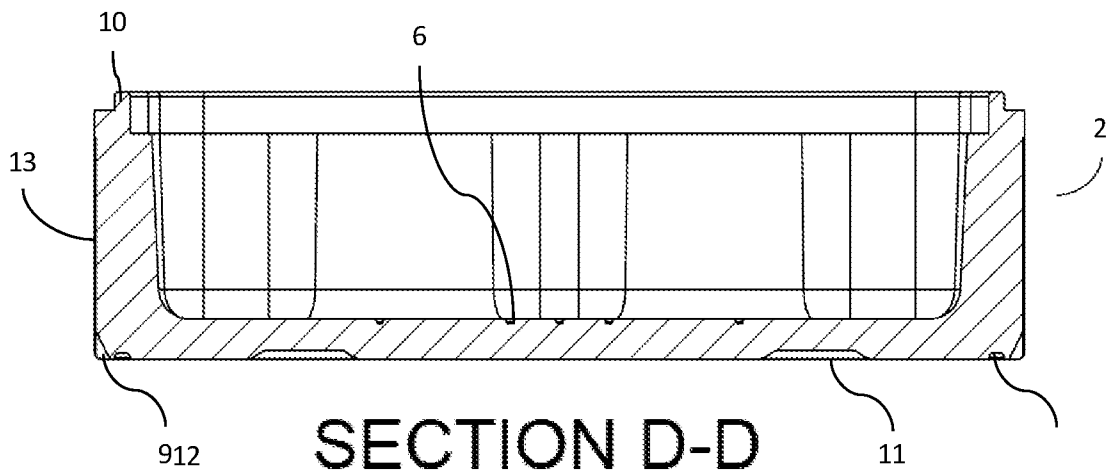

FIG. 2C



SECTION D-D

FIG. 2D

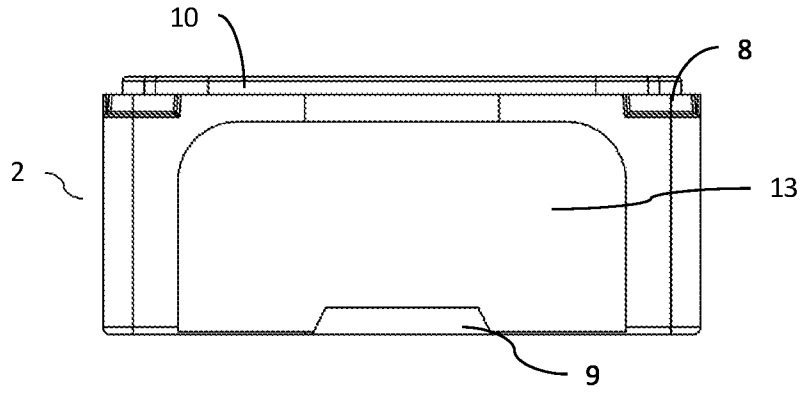

FIG. 2E

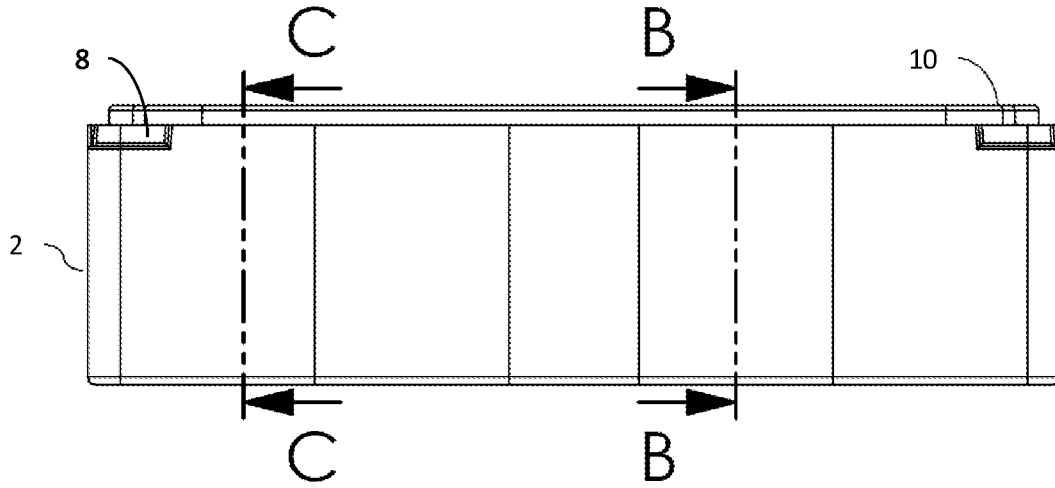

FIG. 2F

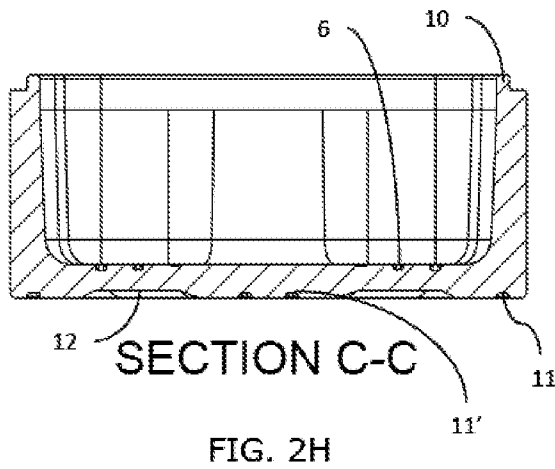

FIG. 2H

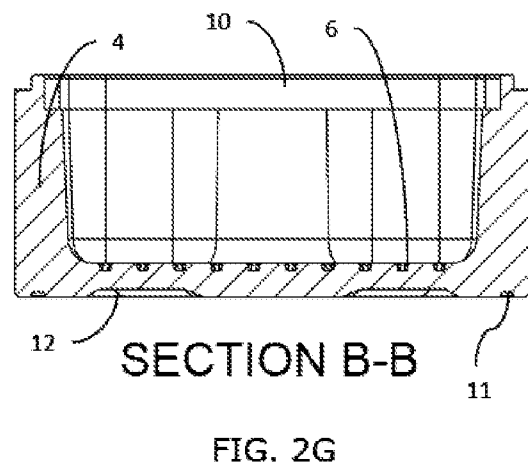

FIG. 2G

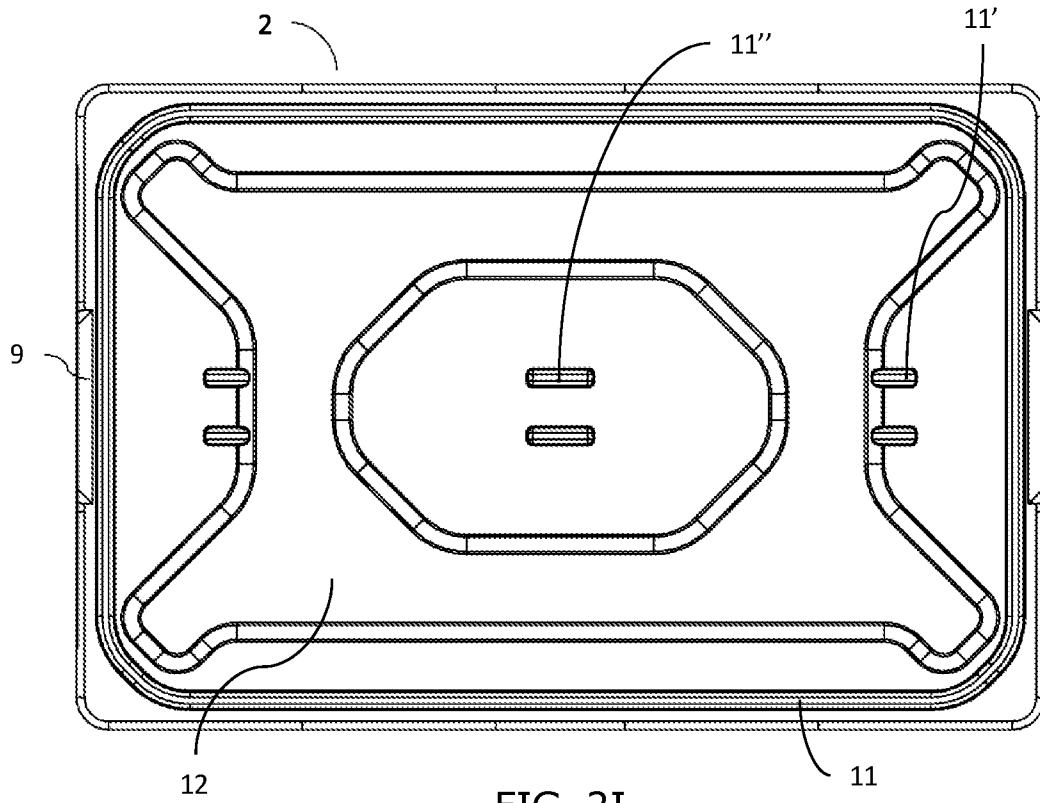

FIG. 2I

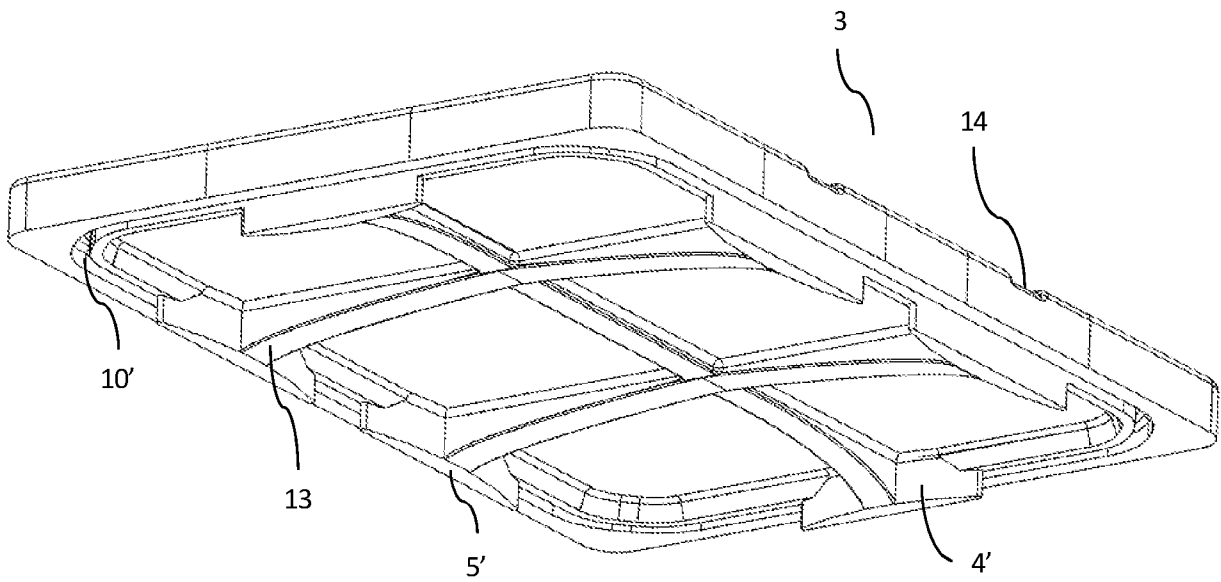

FIG. 3A

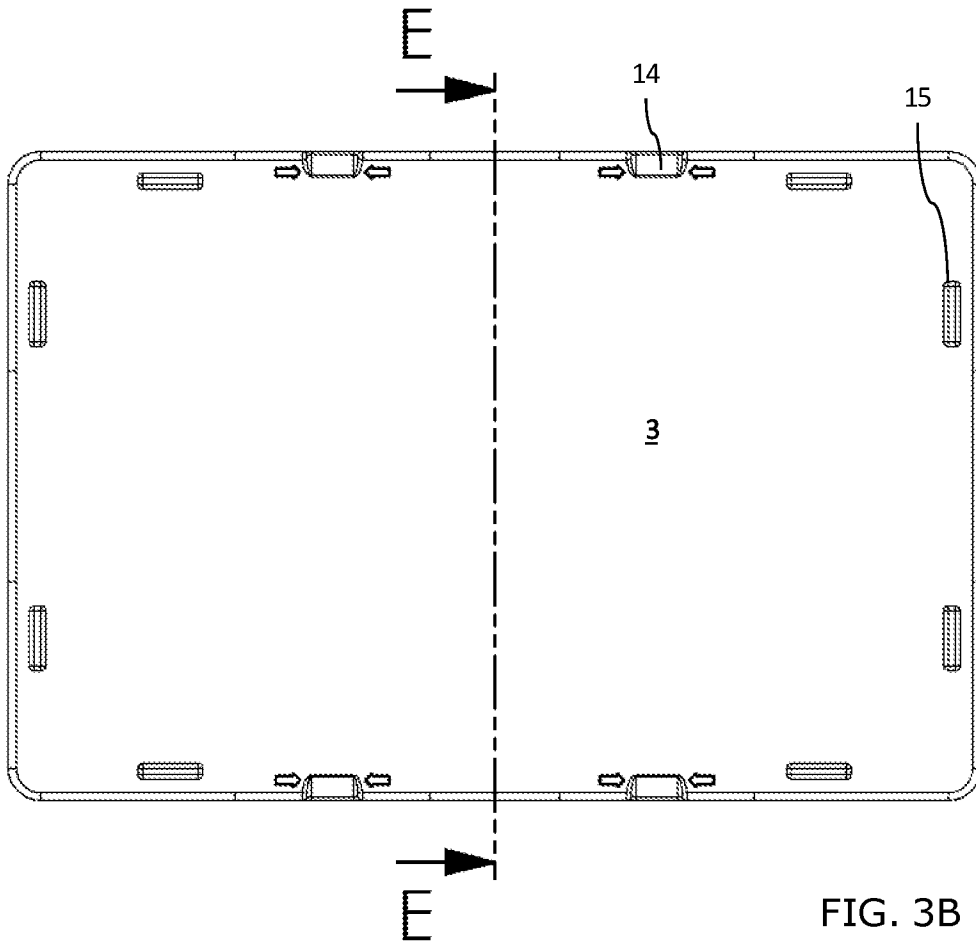

FIG. 3B

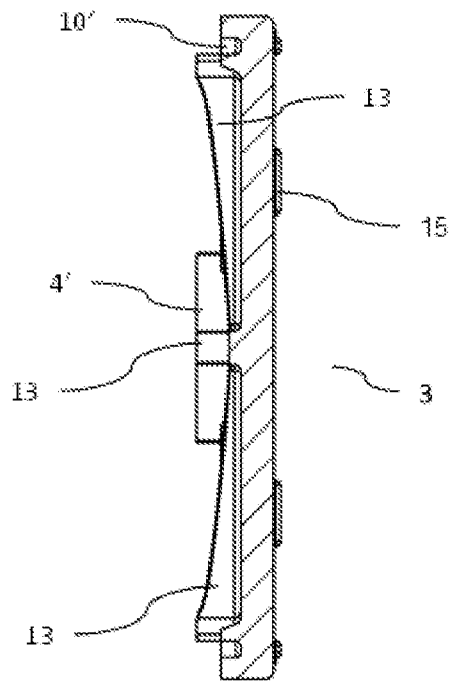

FIG. 3C

SECTION E-E

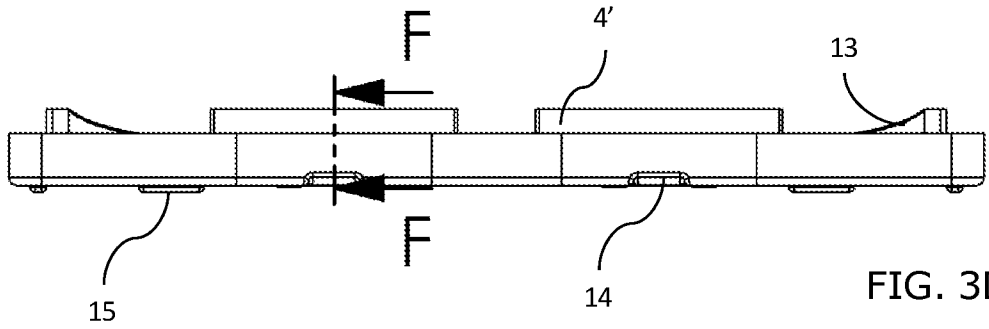
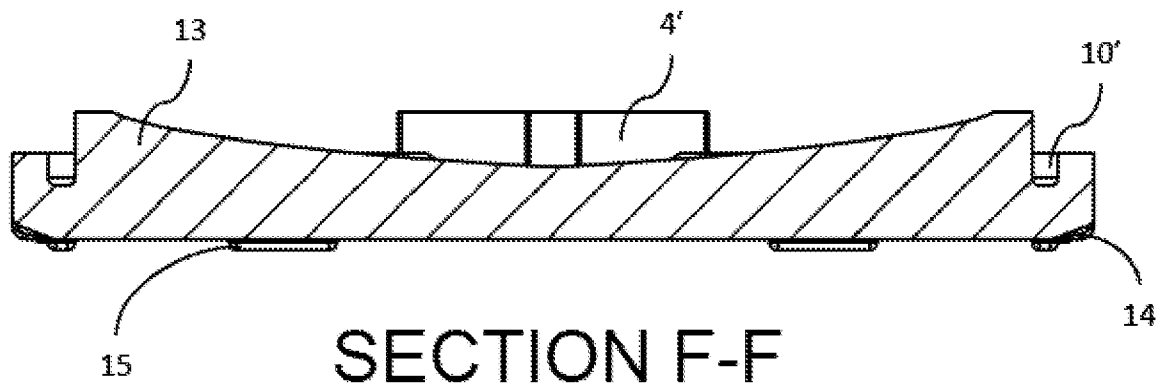

FIG. 3D



SECTION F-F

FIG. 3E

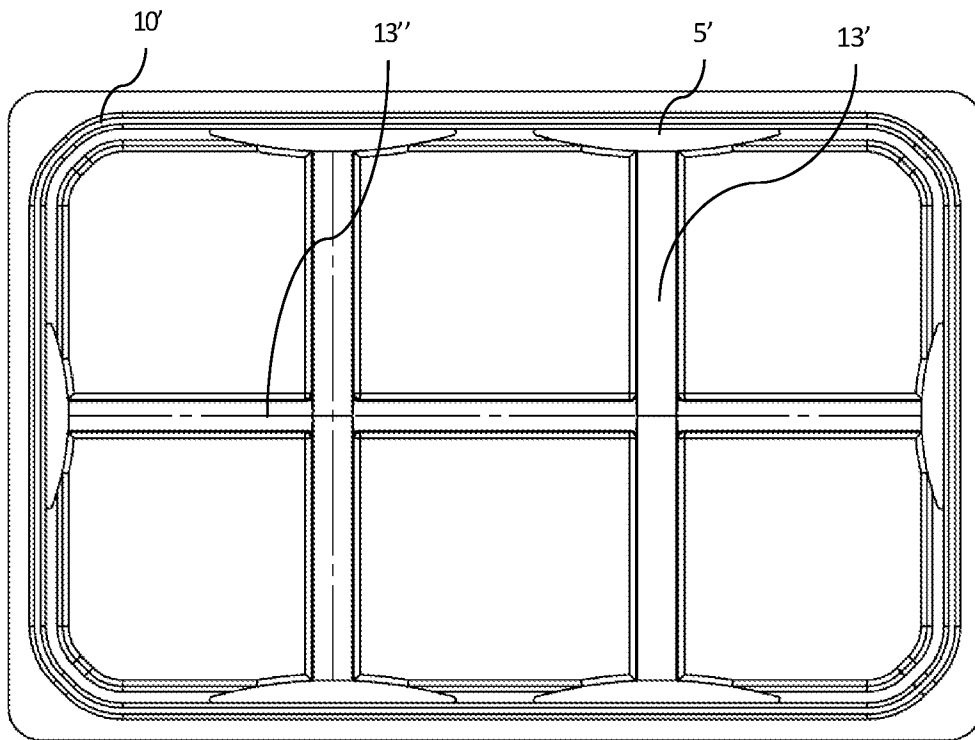

FIG. 3F