

Feb. 7, 1928.

1,658,733

J. S. NAIRN

AMUSEMENT DEVICE

Filed April 22, 1926

2 Sheets-Sheet 1

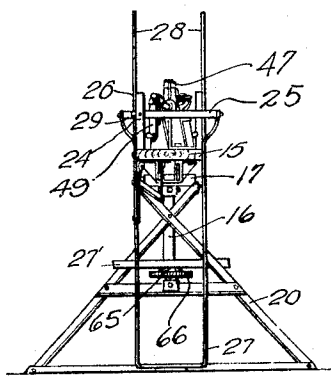
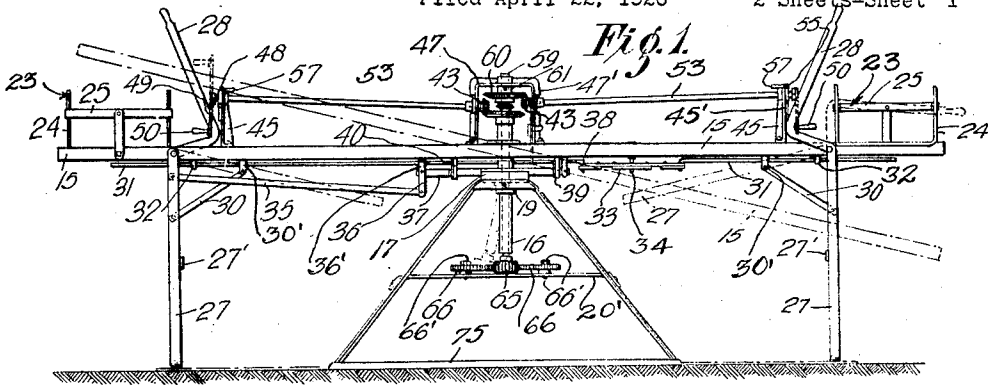

Fig. 2.

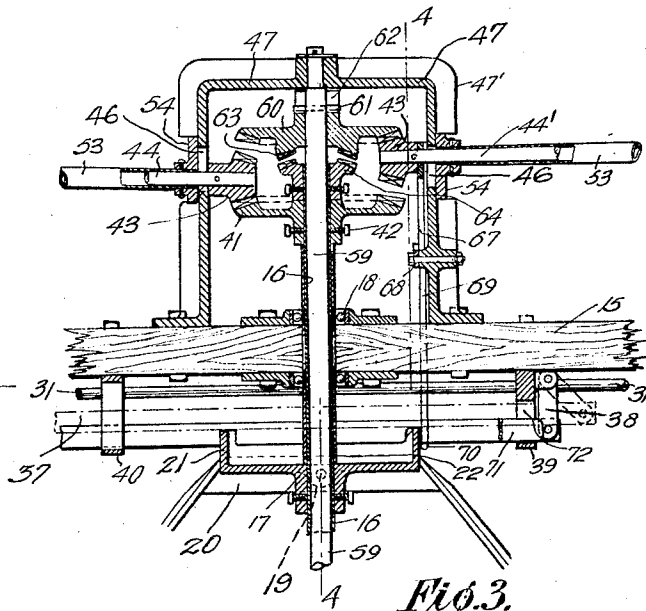

Fig. 3.

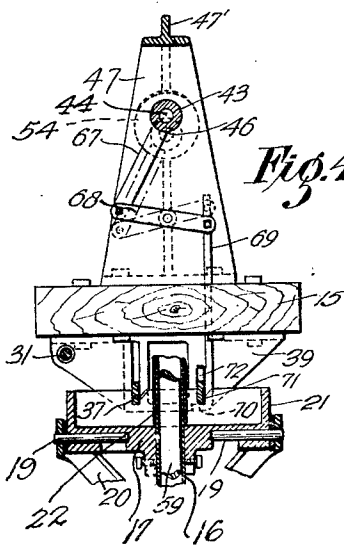

Fig. 4.

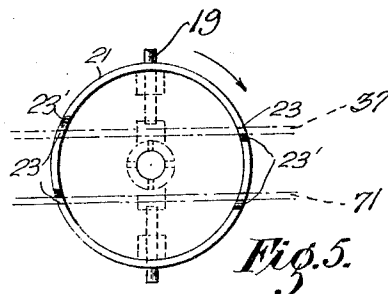

Fig. 5.

John Stenhouse Nairn,
By C. P. Proffel,
his Attorney.

Feb. 7, 1928.

1,658,733

J. S. NAIRN

AMUSEMENT DEVICE

Filed April 22, 1926

2 Sheets-Sheet 2

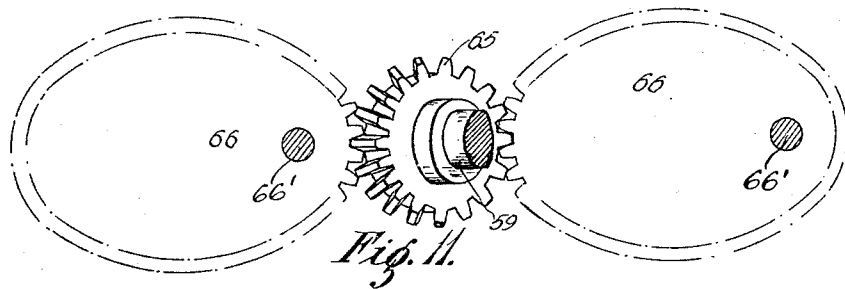
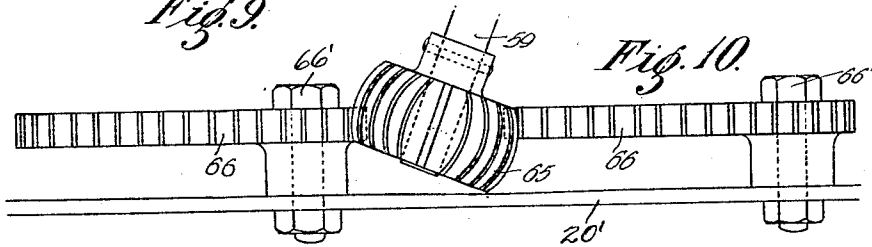
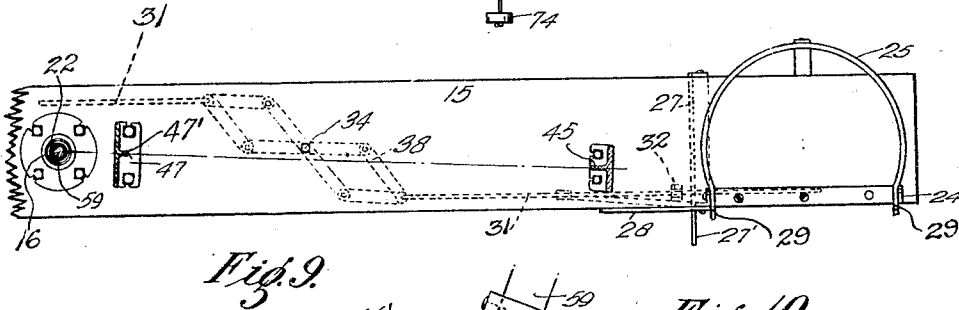
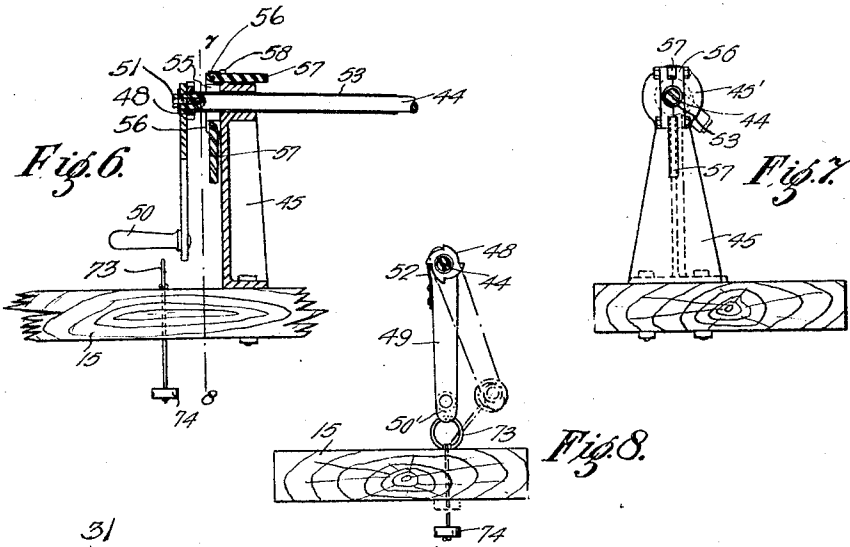

John Stenhouse Nairn,
By C. P. Isofel
his attorney.

UNITED STATES PATENT OFFICE.

JOHN STENHOUSE NAIRN, OF ELWOOD, VICTORIA, AUSTRALIA.

AMUSEMENT DEVICE.

Application filed April 22, 1926, Serial No. 103,705, and in Australia April 27, 1925.

This invention relates to improvements in amusement devices and refers especially to a device adapted to be used as a see-saw, a merry-go-round or as an amusement device of the type commonly known as an ocean wave.

Hitherto, devices of the abovementioned nature have been constructed by mounting a see-saw beam centrally on a ball or like joint fitted to a post whereby the said beam is capable of rotation as well as an oscillatory or see-saw movement.

This type of amusement device has, however, been found in operation to possess many disadvantages as, for instance, children amusing themselves thereon have no positive means of controlling their movement and furthermore accidents often occur as a result of the children falling off or attempting to get off while the beam is in motion.

Now, the object of the present invention is to provide a device which will be adapted to function as a see-saw or merry-go-round, and, when the two movements are combined, as an ocean wave, the said device affording a maximum degree of safety to, and being under the positive control of, the occupants or passengers.

I accomplish the abovementioned objects by providing a passenger carrying member rotatably mounted on an oscillatable member, a frame supporting the oscillatable member, means operable by one or more of the passengers for rotating the beam about the oscillatable member, means operable by one or more of the passengers for rocking the said oscillatable member, and means operable by the passengers whereby the two movements may be produced independently, to function as a see-saw or a merry-go-round, or co-operatively to function as an ocean wave. Coacting locking means on the passenger carrying member and oscillatable member respectively may be provided whereby the former will be prevented from moving until desired.

A particular adaptation of the invention comprises a beam rotatively mounted at its centre on an oscillatable member, a frame pivotally supporting the oscillatable member, seats on the ends of the beam, gearing for rotating the said beam, gearing for rocking the oscillatable member, gear operating mechanism positioned adjacent each seat,

and means positioned adjacent each seat whereby the gear operating mechanism will be caused to actuate either the gearing for rotating the beam, or the gearing for rocking the oscillatable member.

Having now described the object and nature of the invention reference will be made to the accompanying sheets of explanatory drawings, wherein:—

Figure 1 is a view in side elevation of an amusement device constructed and arranged in accordance with the invention.

Figure 2 is a view in end elevation of the device shown in Figure 1.

Figure 3 is a view in sectional side elevation of the operative gearing of the device, and is drawn to a larger scale than the preceding figures.

Figure 4 is a sectional end elevation taken on the line 4—4 of Figure 3.

Figure 5 is a view in plan of the annular locking member 21 shown in Figures 3 and 4.

Figure 6 is a view in sectional side elevation of the operating and control mechanism.

Figure 7 is a view in sectional end elevation taken on the line 7—8 of Figure 6 and looking to the right thereof.

Figure 8 is a view in sectional end elevation taken on the line 7—8 of Figure 6 and looking to the left thereof.

Figure 9 is a view in sectional plan of portion of the beam and members fitted thereto; and

Figure 10 is a view in side elevation, and

Figure 11 a plan of the gearing for oscillating the device.

Referring now to the drawings, 15 is a beam which is revolvably mounted at the centre thereof on a tube 16 which is rigidly secured to and forms part of an oscillatable member 17, ball bearings 18 being preferably provided to diminish frictional resistance.

The oscillatable member 17 is fitted with laterally projecting trunnions 19, which are pivotally accommodated in the side members of a pyramidal shaped pedestal or frame 20 which is suitably braced to withstand the stresses to which it is subjected.

An annular locking member 21 is formed integrally with the oscillatable member 17, or alternatively it may be rigidly secured thereto, and the same is formed with two

pairs of opposed slots 23 which are arranged one on each side of, and at equal distances from, the centrally disposed tube 16.

Each pair of slots 23 has two of its diagonally opposite sides formed with ramps or inclined faces 23' (see Figure 5).

A tube 22 surrounds the tube 16 and carries the stationary drive crown gear to be more fully hereinafter described.

The ends of the beam 15 are provided with seats 23 which are each adapted to accommodate a child and which may be formed (as shown) by means of U shaped members, 24, rigidly secured to opposite sides of the beams and having attached thereto horizontal members 25 the free ends 26 of which project slightly beyond the vertical portions of the U shaped members 24 the upper ends of which also extend above the top of the horizontal members 25.

Each end of the beam 15 is provided with a supporting member 27 which is pivotally secured to the said beam and is provided with a laterally projecting bar 27' which serves as a step to enable a child to conveniently reach the seat.

The supporting members 27 are formed integrally with or rigidly secured to levers 28 which are positioned adjacent the open sides of the seats and are of such formation that when a child is in one of the seats the said lever adjacent thereto may be depressed to engage slots 29 formed in the projecting ends 26 of the horizontal members 25, thus closing the open side of the seat and, at the same time, raising the supporting members 27 clear of the ground as clearly shown in broken lines in the right hand side of Figure 1 of the drawings.

The supporting members 27 are connected as at 30' by links 30 with rods 31 reciprocatingly mounted in bearings 32 secured to the underside of the beam 15 and the inner ends of the rods are connected to opposite ends of a series of jointed links or lazy-tongs 33 which is pivotally attached at the centre thereof to the beam 15 by a bolt 34 (see Figures 1 and 9 of the drawings).

By connecting the supporting members 27 in this way the same are constrained to move in unison so that when the child at one end of the beam depresses the lever 28 positioned adjacent his seat, the lever 28 at the opposite end of the beam is simultaneously depressed.

One of the supporting members 27 is also connected by a link 35 to the lower end of a depending lever 36 which is pivoted at its upper end to a bracket 36' secured to the underside of the beam.

A locking bar 37 has one of its ends pivotally connected to the lever 36 at a point intermediate its ends and the opposite end is pivotally connected at a similar radius to a lever 38 depending from a lug formed on

a guide bracket 39, positioned on the opposite side of the centre of the beam to the first mentioned lever 36.

A guide bracket 40 is also secured to the underside of the beam adjacent to the lever 36.

When the supporting members 27 are in a vertical position the locking bar 37 is partially accommodated in one pair of the opposed slots 23, formed in the annular locking member 21 thus preventing rotation of the beam 15, when, however, the supporting members 27 are raised the locking bar 37 is also raised clear of the annular locking member 21.

A bevel crown wheel 41 is rigidly attached to the tube 16 above the beam 15 by means of set screws 42 and the same is adapted to mesh with bevel pinions 43 secured to the inner ends of longitudinally extending spindles 44 the outer ends of which are supported in bearing brackets 45 secured to the top of the beam in proximity to the seats.

The inner ends of the spindles 44 at the rear of the pinions 43 pass through slots 46 formed in the side members of a saddle shaped bracket 47 which is bolted to the top of the beam.

The outer ends of the spindles are rigidly fitted with ratchets 48, and crank arms 49 provided with gripping handles 50 are freely mounted on the said spindles, the said crank arms being retained thereon by set screws 51 (see Figures 6 and 8).

A pawl comprising a spring 52 is secured to each crank arm 49 and the same is adapted to engage the teeth on its respective ratchet 48.

If desired the ratchets 48 may be dispensed with and the crank arms rigidly attached to the ends of the spindles 44.

A tube 53 is mounted freely on each of the spindles 44 and the inner ends of the same are rigidly attached to eccentrics 54 which are mounted in gaps formed in the webs 47' of the bearing bracket 47.

The outer ends of the tubes 53 pass through the brackets 45 and are provided with clamps 55 each having a pair of laterally projecting lugs 56 formed thereon. A latching member 57 is pivotally secured between each pair of lugs 56 and a slot 58 corresponding in width to the said latching members is formed in the top of the flange 45' of each bracket 45.

The short ends of the latching members 57 are of such formation that the same are prevented from falling outwardly to foul the crank arms 49.

It will be obvious, from an inspection of the drawings, that, when the tubes 53 are given half a turn, and the opposite latching member 57 is caused to engage the slot 58 in the flange 45' of the bracket 45, the eccentrics 54 will raise or lower the pinions

43 out of or into mesh with the bevel crown wheel 41.

A spindle 59 is rotatively mounted in the tube 16 and is suspended from its upper end by means of a split pin and washer resting on a boss formed on the bracket 47.

The upper end of the spindle 59 projecting through the boss on the bracket 47 is reduced in diameter to form a shoulder adapted to prevent the same from rising.

A bevel crown wheel 60 is mounted on the spindle 59 below the top of the bracket 47 in such a manner that the same is capable of a slight axial movement on but is constrained to rotate with the spindle, this result being effected by a transverse pin 61 in the spindle engaging a longitudinally disposed slot 62 in the boss of the said bevel crown wheel 60.

A clutch member which in the adaptation of the invention illustrated in the drawings takes the form of an internal bevel gear 63 is rigidly secured to or is formed integrally with the bevel wheel 60 and a corresponding clutch member 64 is secured to the upper end of the tube 16 or, if desired, the same may be formed integrally with the bevel wheel 41.

When both bevel pinions 43 are in their lower positions and engaging the bevel crown wheel 41 the upper bevel crown wheel 60 moves axially until the coacting clutch members 63 and 64 engage the one with the other, thus preventing rotation of the spindle 59.

A gear wheel 65 which is preferably formed as a frustum of a sphere is rigidly secured to the lower end of the spindle 59 and the same is in constant mesh with a pair of elliptic gear wheels 66 which are each pivotally mounted at one of their focal points on bolts 66' secured to a horizontal bar 20' forming part of the base or pedestal 20.

When either of the bevel pinions 43 is moved into its upper position by giving a partial rotation to the tube 53 surrounding the spindle 44 fitted thereto, the said pinion engages with the bevel crown wheel 60 and raises the clutch member 63 clear of the clutch member 64 as clearly shown in Figure 3. Any subsequent rotation of the spindle 44 connected to the said pinion will cause the spindle 59 to rotate the elliptic gearing 66, the effect of which is to cause the gear 65 to oscillate backwards and forwards along an arc, the centre of which is constituted by the trunnions 19.

The oscillatory motion of the gear is communicated to the oscillatable member 17 and beam 15 by means of the spindle 59, the tilted position of the beam on one side of its normal position being shown by chain dotted lines in Figure 1 of the drawings.

One of the spindles 44 is connected by a

link 67 to one end of a lever 68 pivoted at its centre to the bracket and the opposite end thereof is pivotally secured to a depending rod 69 having a hook or abutment 70 formed on its lower end.

The hook or abutment is adapted to engage the bottom edge of a safety bar 71 which normally engages the second pair of slots 23 in the annular locking member 21 and has its ends mounted in slots 72 in the brackets 39 and 40.

When, however, the spindle 44 and pinion 43 connected to the link 67 are depressed, the rod 69 will be moved upwardly, the abutment 70 thereon at the same time raising the safety bar 71 from the slots 23.

The guide slot 72 in the bracket 39 is made of such size that when the end of the safety bar accommodated therein has been raised to a predetermined height the upper edge of the same will pivot on the edge of the slot so that the opposite end will be raised clear of the annular locking member. The mechanism for raising the safety bar is preferably so adjusted that when the same is fully raised its lower edge is still slightly below the top of the annular locking member 21.

When the pinion or pinions 43 are rotated in such a manner as to cause the beam 15 to move in the direction of the arrow shown in Figure 5, the safety bar merely moves up the ramp 23', in succession. Retrograde movement, however, is prevented by the said bar 71 coming into contact with the vertical faces of the slots.

In operation, after a child has entered each seat, the levers 28 are depressed to engage the slots 29, formed in the projecting ends 26 of the horizontal members 25, thus locking the occupants in their seats, and, at the same time, raising the supporting members 27 clear of the ground (see right hand side Figure 1).

Simultaneously also with the elevation of the supporting members 27 the locking bar 37 is raised clear of the slot 23 in the annular locking member 21 in which it is normally positioned, through the medium of the lever 36 and link 35.

If the occupants desire to see-saw, the bevel pinions are placed in the positions shown in Figures 1 and 3 by rotating the eccentrics and retaining the same in position by means of the latching members 57.

When the bevel pinion shown on the right hand side of Figure 3 is elevated and meshes with the bevel crown wheel 60, the safety bar 71 is depressed and engages one of the pairs of opposed slots 23, and it will be understood that both the locking bar 37 and the safety bar 71 must be elevated above the annular locking member 21 before the beam 15 can rotate about the tube 16; therefore, when the right hand pinion is raised, the beam cannot rotate or swing from side to side.

When the bevel crown wheel 60 is rotated by means of the crank arm 49 associated with the bevel pinion in mesh therewith, the elliptic gears 65 and 66 are rotated, and cause the spindle 59 and beam 15 to oscillate backwards and forwards as clearly evidenced in the drawings, the trunnions being the centre of oscillation of the device. As it is impossible to rotate the left hand bevel pinion 43, while the same is in mesh with the bevel crown wheel and the safety bar 71 is engaging the annular locking member 21, the said bevel pinion could also be raised to mesh with the bevel crown wheel 60 and assist in the see-saw or oscillatory movement.

The resiliency of the frame or pedestal assists the see-saw movement by preventing undue shock and consequent strain on the parts when the beam is being brought to rest at the ends of the alternate up and down movements.

Upon lowering both bevel pinions into engagement with the lower bevel crown wheel 41, the upper crown wheel will fall by gravity until the coacting clutch members 63 and 64 engage the one with the other and lock the spindle to the oscillatable member 17. In this position the teeth of the upper wheel 60 will be disengaged from the pinions and the spindle will lock as a unit with the gear 41 thus holding the parts against movement, yet permitting the beam 15 to rotate freely about the tube 22. Since the locking bar 37 has been released by the elevation of the supporting members 27 and the safety bar is raised clear of the annular locking member 21 by the lowering of the pinions 43 operating through the lever 68, link 67 and rod 69, rotation of the bevel pinions will cause the beam 15 to rotate in the direction shown by the arrow in Figure 5 and the device may thus be used as an ordinary merry-go-round. As previously explained, the vertical faces of the slots 23 prevent any reverse movement of the beam.

Obviously by imparting motion to the upper gear wheel 60 prior to its lowering movement, the gears 65 and 66 will be operated to move the spindle 59 and beam 15 into an inclined position as shown in chain dotted lines in Figure 1, after which the pinions are caused to engage the lower bevel crown wheel 41 and disengage the crown wheel 60.

The coacting clutch members will then lock the spindle in its inclined position, and the beam may be rotated thereabout in a plane more or less inclined to the horizontal. This I call a "toboggan" movement.

In order that the see-saw and rotary movements may be combined to produce a rotatory undulatory movement or "ocean-wave" effect, the right hand bevel pinion, referring to Figure 3, is caused to engage the lower bevel crown wheel 41 while the left hand bevel pinion is caused to engage the upper

bevel crown wheel 60. The crank arm 49 associated with the left hand bevel pinion is preferably restrained from rotating by placing a ring 73 attached by a cord to a small weight 74 positioned on the underside of the beam 15, around the handle 50 attached thereto (see Figures 6 and 8).

The rotation of the right hand bevel pinion will cause the beam 15 to rotate and, at the same time, the left hand bevel pinion being restrained by the ring 73 from rotating will cause the upper bevel crown wheel to rotate, thus superimposing the oscillatory movement upon the rotary movement.

If desired, the restraining means may be dispensed with and the crank held or rotated by the hand.

A brake of any well-known or suitable construction and operable by the occupants of one or both seats may be fitted to the device if desired to retard when necessary the rotation of the beam 15.

When the device is positioned on a lawn or floor a longitudinally extending member such as a plank 75 may be placed therebelow in order to prevent the supporting members 27 injuring the surface thereof when the same are in a vertical position.

It is to be understood that two or more beams 15 may be employed in the device, the said beams being spaced at regular intervals about the central pivotal support, and that such structure involves no difference of function as one, two or more of the seats may have an operating crank arranged in proximity thereto, and the same could be constructed without difficulty by anyone skilled in the art.

Whilst the preferred form of the invention has been described and illustrated, it will be obvious that various modifications, alterations and rearrangements of parts may be effected without departing from the spirit and scope of the invention and for this reason I do not wish to be confined to or limited by the specific terms employed in the description.

In the following claiming clauses, where the term "oscillatable member" is used, it is intended to include within its scope any member which is rigidly fitted thereto or formed integrally therewith, such as, for example, the tube 16 and the annular locking member 21.

An amusement device constructed, arranged and operating in accordance with the present invention will be found safe and positive in operation and low in manufacturing costs.

I claim:

1. An amusement device comprising a passenger carrying member mounted for rotatable and oscillatory motion and manually operable mechanism for imparting both motions to the passenger carrying member

simultaneously or either motion to said member independently.

2. An amusement device comprising a rotatable passenger carrying member, mounted for rotatable and oscillatory motion, actuating means associated with the passenger carrying member and operable by passengers thereon to impart both motions simultaneously or either motion independently thereto, and passenger controlled means to select such of said motions as may be desired.

3. An amusement device comprising a rotatable passenger carrying member, an oscillatable member rotatably supporting the passenger carrying member, at or near its centre, a relatively fixed frame supporting the oscillatable member, seats on the passenger carrying member, gearing for rotating said passenger carrying member, gearing adapted to rock the oscillatable member, gear operating mechanism positioned adjacent each seat, and means for causing the gear operating mechanism to actuate either the gearing for rotating the passenger carrying member or the gearing for rocking the oscillatable member.

4. An amusement device comprising a rotatable passenger carrying member, an oscillatable member rotatably supporting the passenger carrying member, at or near its centre, a relatively fixed frame supporting the oscillatable member, toothed gearing adapted to rock the oscillatable member, toothed gearing adapted to rotate said passenger carrying device, gear operating mechanism mounted in convenient positions on the passenger carrying device, and means for adjusting the gear operating mechanism to actuate either the gearing for rotating the beam or the gearing for rocking the oscillatable member.

5. An amusement device comprising a rotatable beam, an oscillatable member rotatably supporting the beam at or near its centre, a relatively fixed frame supporting the oscillatable member, gearing adapted to rotate the beam, gearing adapted to rock the oscillatable member, a locking member on the oscillatable member, a locking means on the said beam adapted when engaged to prevent rotation thereof, a seat at each end of the beam, means for closing the seats when occupied, means disengaging the locking means simultaneously with the movement of the seat closing means to closed position, gear operating means positioned adjacent each seat, and means operable from each seat for causing gear operating means to actuate either the gearing for rotating said beam or gearing for rocking said oscillatable member.

6. An amusement device comprising a rotatable passenger carrying member, an oscillatable member rotatably supporting the

passenger carrying member at or near its centre, a relatively fixed frame supporting the oscillatable member, seats on the passenger carrying member, a centrally disposed spindle revolvably mounted in the oscillatable member and passing vertically through said passenger carrying member, a bevel crown wheel rigidly secured to the oscillatable member above the said passenger carrying member, a bevel crown wheel mounted on and constrained to rotate with the centrally disposed spindle, the same being disposed above the first mentioned bevel crown wheel, radially extending spindles having their outer ends terminating near the said seats, hand operated cranks on the said outer ends of the spindles, bevel pinions on the inner ends of the radially extending spindles and means operable from the said seats for independently raising and lowering the bevel pinions to engage either one or the other of the said bevel crown wheels.

7. An amusement device of the type described comprising a beam revolvably mounted on an oscillatable member, a frame, trunnions projecting laterally from the oscillatable member and accommodated in said frame, a seat on each end of said beam, a bevel wheel rigidly secured to the oscillatable member above said beam, a centrally disposed spindle rotatably mounted in and co-axial with the oscillatable member, a bevel crown wheel mounted on the said spindle, and constrained to rotate therewith, longitudinally extending spindles having their outer ends terminating adjacent to the said seats, bevel pinions on the inner ends of the longitudinally extending spindles, cranks on the outer ends of the said spindles and means for raising and lowering the bevel pinions to engage either the bevel crown wheel on the centrally disposed spindle or the bevel crown wheel on the upper end of the oscillatable member.

8. In an amusement device as claimed in claim 6, a gear on the lower end of the centrally disposed spindle, and opposed elliptic gears meshing with the said gear, whereby when the same are rotated the oscillating member is caused to rock.

9. In an amusement device as claimed in claim 6, a bracket supporting the inner ends of the radially extending spindles and the upper end of the said centrally disposed spindle, slots in the said bracket adapted to allow a limited vertical movement to the said radial spindles, abutments above and below the said slots, a tube mounted freely and concentrically on each of the radially extending spindles, eccentrics rigidly attached to the inner ends of the said tubes, and riding against the bracket between the abutments whereby when the same are rotated the said bevel pinions will be raised or

lowered, and means associated with the outer ends of the tubes for retaining the same in their adjusted positions.

10. In an amusement device as claimed in claim 7, a bracket attached to each end of the beam and supporting the said longitudinally extending spindles, a central bracket supporting the inner ends of the spindles, a tube mounted freely and concentrically on each of the said spindles, abutments on the said central bracket, eccentrics rigidly secured to the inner ends of the tubes in engagement with opposite sides of the central bracket and between the abutments, a member secured to the outer end of each of the said tubes, latching members pivotally mounted in said members, and a recess in each of said first mentioned brackets to accommodate one of said latching members whereby when said tubes are rotated eccentrics will cause bevel pinions to be raised or lowered into or out of mesh with the said bevel crown wheels.

11. In an amusement device as claimed in claim 5, a supporting member pivoted to the beam in proximity to each seat and adapted normally to rest on the ground, means to raise the supporting member off the ground upon operation of the seat closing means, means for causing the seat closing to move in unison and means for retaining the seat closing means in their closed positions.

12. In an amusement device as claimed in claim 7, an annular locking member rigidly secured to the oscillatable member, and having a pair of opposed slots formed on each side of and at equal distances from the centre of said annular locking member, links depending from the underside of the beam and on opposite sides of the centre thereof, a locking bar having its ends pivotally connected to the said depending links, levers pivoted to the beam adjacent each seat and adapted when depressed to close said seats, and means associated with one of the said levers whereby when the same is depressed the said locking bar will be raised clear of the slots in the said locking member.

13. In an amusement device as claimed in claim 7, an annular locking member secured to the oscillatable member, a pair of opposed slots on each side of, and at equal distances from, the centre of said annular locking member, a vertically movable safety bar on the beam, adapted to engage one of the said pairs of slots, a central bracket supporting the inner ends of the longitudinally extending spindles, a double ended lever pivoted to the central bracket, a link connection between one of the longitudinally disposed spindles and one end of the said double ended lever, a depending member connected to the opposite end of the double ended lever, and an abutment on the depending member engaging the safety bar, whereby when the longitudinally extending spindle is in its

lower position the safety bar will be raised clear of the said annular locking member.

14. In an amusement device as claimed in claim 7, an annular locking member secured to the oscillatable member, a pair of opposed slots on each side of and at equal distances from the centre of the annular locking member, a central bracket supporting the inner ends of the longitudinally extending spindles, a vertically movable safety bar on the beam adapted to engage one pair of the said slots and normally positioned with its lower edge just below the top of the annular locking member, means for causing the safety bar to engage the slots when one of the longitudinally extending spindles is raised, and a ramp on one side of each of the slots whereby when the safety bar is raised, the beam can rotate in one direction only.

15. An amusement device as claimed in claim 7, characterized in that the bevel crown wheel on the upper end of the centrally disposed spindle is capable of axial movement, a clutch member is secured to the upper end of the oscillating member, and a coacting clutch member is formed on or rigidly attached to the said bevel crown wheel whereby when both bevel pinions are lowered the bevel crown wheel will move axially and allow the coacting clutch members to engage and prevent rotation of the said spindle.

16. An amusement device as claimed in claim 7, characterized in that the crank arms are freely mounted on the ends of the longitudinally extending spindles, a ratchet is rigidly attached to each of the said spindles, and pawls on the crank arms which are adapted to engage the teeth on the ratchets.

17. In an amusement device as claimed in claim 7, a supporting member pivoted to the beam adjacent each seat, steps on the supporting members, a lever rigidly attached to each supporting member, said levers being of such formation as to close the seats when depressed, rods reciprocatingly mounted on the underside of the beam, links connecting the supporting members to the said rods, and a series of jointed links pivoted at its centre to the beam and having its opposite ends connected to the said rods, constructed and arranged whereby when one lever is depressed to raise the supporting member attached thereto, the other lever and supporting member will be constrained to move in unison therewith.

18. An amusement device comprising a frame, an oscillatable member pivotally supported in said frame, a beam rotatably mounted on the oscillatable member, a seat at each end of the said beam, a centrally disposed spindle mounted rotatably and concentrically on the oscillatable member, a bevel crown wheel secured to the oscillatable member above the beam, a bevel crown wheel

constrained to rotate with but capable of axial movement on the centrally disposed spindle, the same being disposed above first mentioned bevel crown wheel, a central
5 bracket supporting the upper end of said spindle, longitudinally extending spindles having their outer ends positioned adjacent the said seats, brackets supporting the outer ends of the said spindles, hand operable
10 cranks on the spindles, bevel pinions on the inner ends of the said spindles, tubes surrounding the spindles, eccentrics rigidly secured to the inner ends of the tubes and bearing on abutments on the central bracket,
15 the rotation of said tubes thereby causing the bevel pinions to engage with the upper or lower bevel crown wheel, means for retaining the bevel pinions in their adjusted positions, a clutch member on the oscillatable

member, a coacting clutch member on the upper bevel crown wheel and arranged to engage when both bevel pinions are meshing with the lower bevel crown wheel, means for supporting the ends of the beam when the device is not in use, and locking means associated with said supporting means, to prevent rotation of the beam. 20 25

19. In an amusement device as claimed in claim 7, gripping handles on the crank arms, a ring normally resting on the top, and at one end, of the beam, and a weight on the underside of the beam and attached to said ring by a flexible member, said rings being adapted to engage gripping handles and prevent rotation of the cranks. 30 35

In witness whereof I hereunto affix my signature.

JOHN S. NAIRN.