



(19) **United States**
(12) **Patent Application Publication**
Rasdal et al.

(10) **Pub. No.: US 2011/0201910 A1**
(43) **Pub. Date: Aug. 18, 2011**

(54) **INTEGRATED RECEIVER FOR CONTINUOUS ANALYTE SENSOR**

filed on Jul. 13, 2004, provisional application No. 60/614,683, filed on Sep. 30, 2004.

(75) Inventors: **Andrew Rasdal**, San Diego, CA (US); **James H. Brauker**, Addison, MA (US); **Paul V. Neale**, San Diego, CA (US); **Peter C. Simpson**, Encinitas, CA (US)

Publication Classification

(51) **Int. Cl.**
A61B 5/1468 (2006.01)
A61B 5/145 (2006.01)
(52) **U.S. Cl.** **600/347; 600/365**

(73) Assignee: **DexCorn, Inc.**, San Diego, CA (US)

(57) **ABSTRACT**

(21) Appl. No.: **13/092,538**

A system is provided for monitoring glucose in a host, including a continuous glucose sensor that produces a data stream indicative of a host's glucose concentration and an integrated receiver that receives the data stream from the continuous glucose sensor and calibrates the data stream using a single point glucose monitor that is integral with the integrated receiver. The integrated receiver obtains a glucose value from the single point glucose monitor, calibrates the sensor data stream received from the continuous glucose sensor, and displays one or both of the single point glucose measurement values and the calibrated continuous glucose sensor values on the user interface.

(22) Filed: **Apr. 22, 2011**

Related U.S. Application Data

(60) Continuation of application No. 12/182,008, filed on Jul. 29, 2008, which is a division of application No. 10/991,966, filed on Nov. 17, 2004, now Pat. No. 7,519,408.

(60) Provisional application No. 60/523,840, filed on Nov. 19, 2003, provisional application No. 60/587,787,

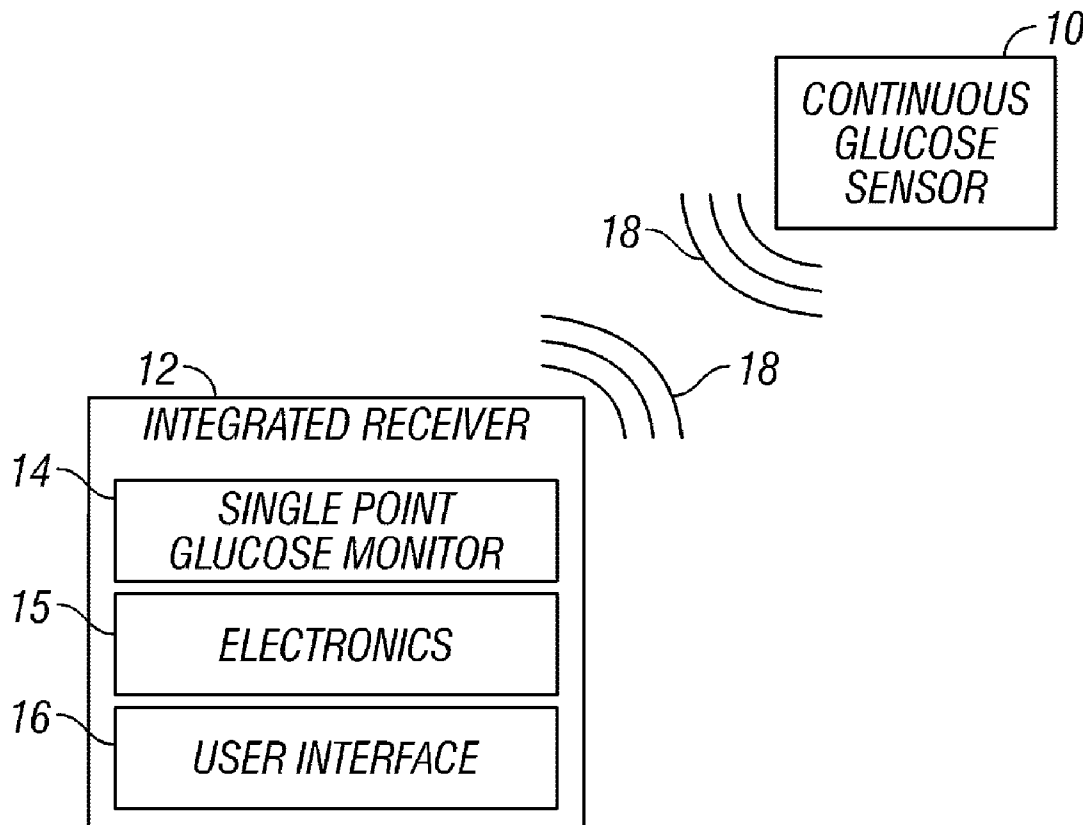

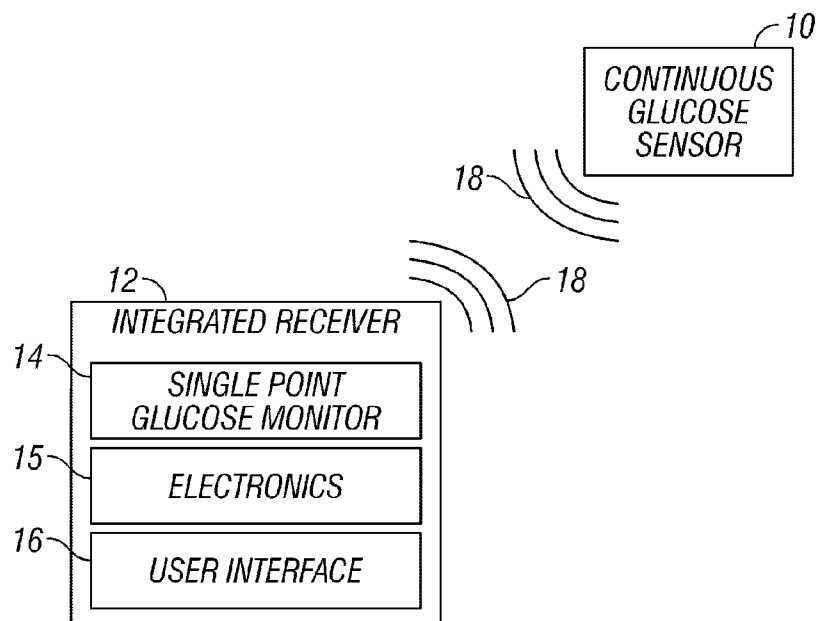

FIG. 1

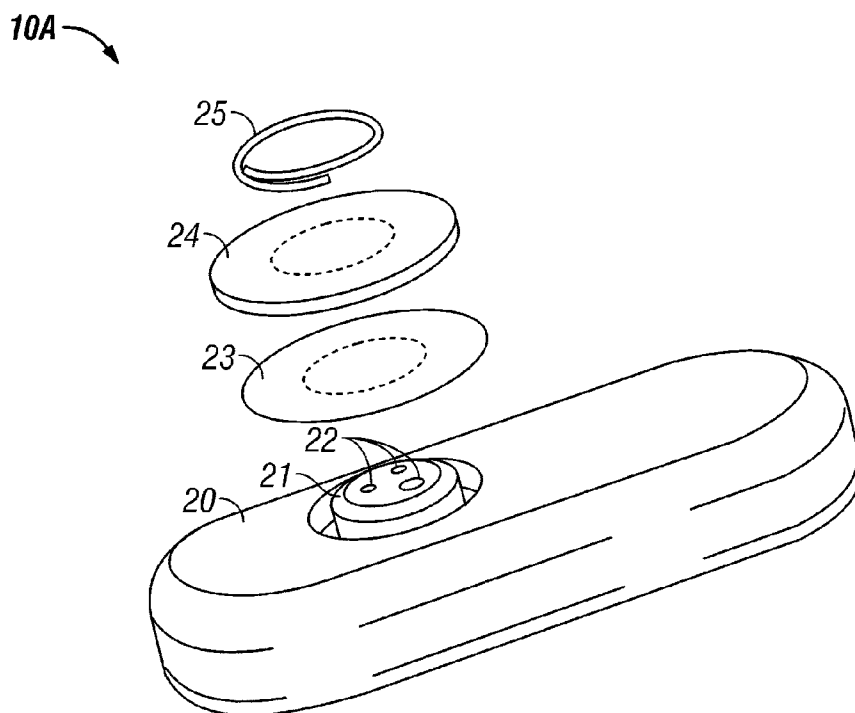

FIG. 2A

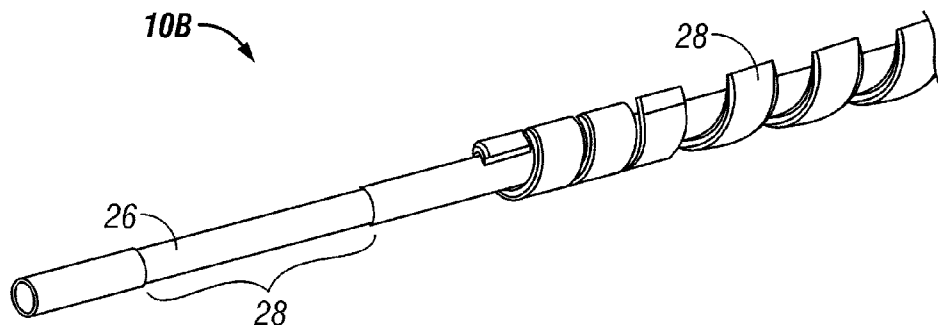

FIG. 2B

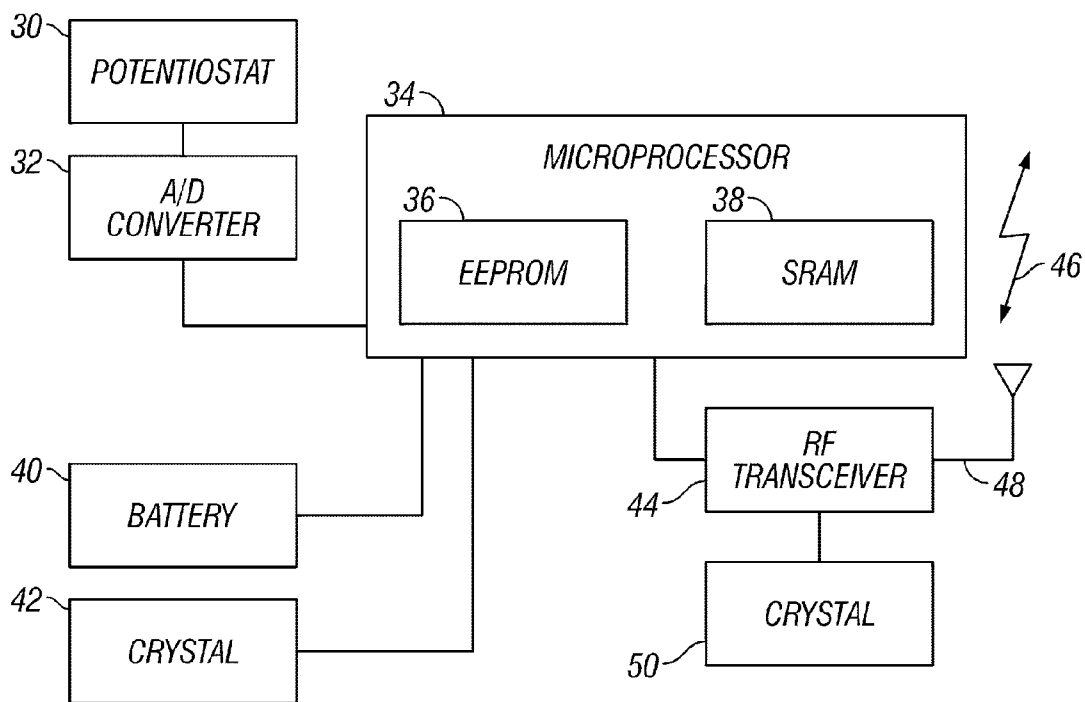

FIG. 3

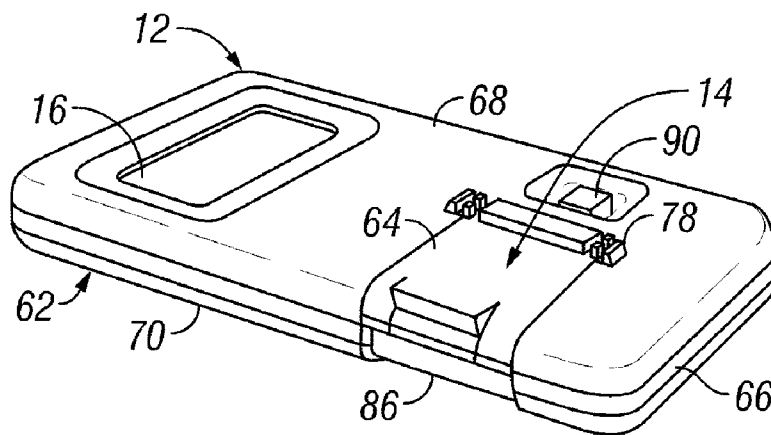

FIG. 4A

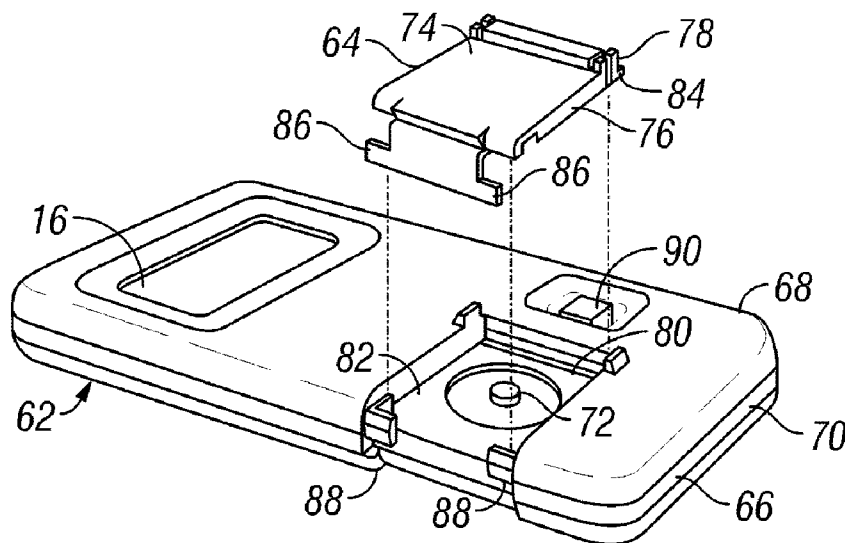

FIG. 4B

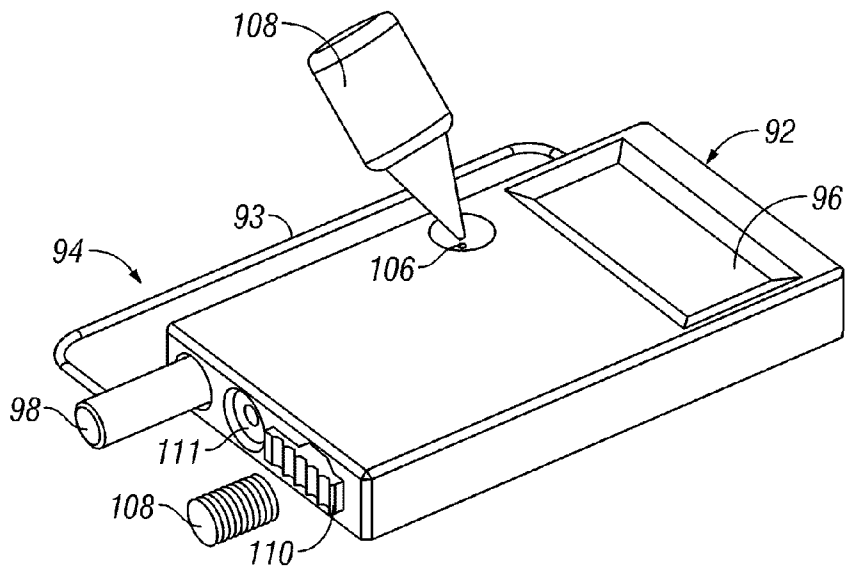

FIG. 5A

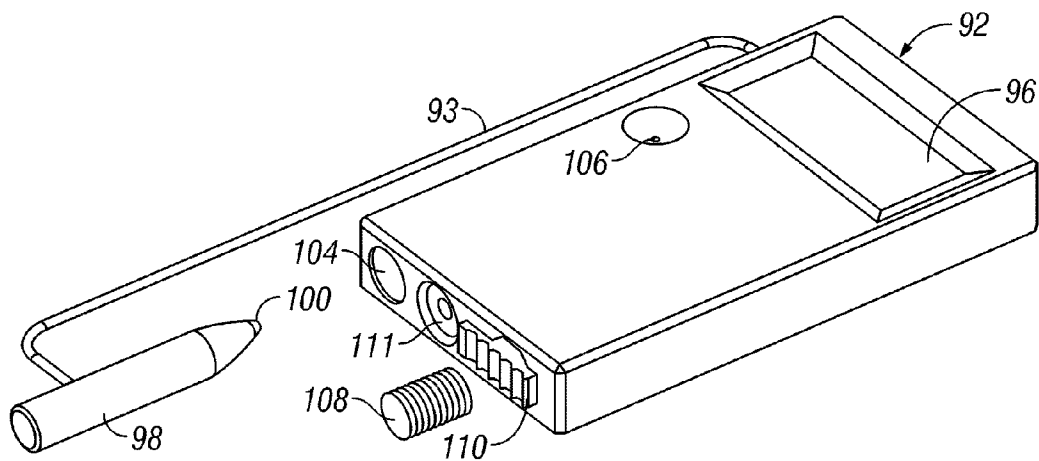

FIG. 5B

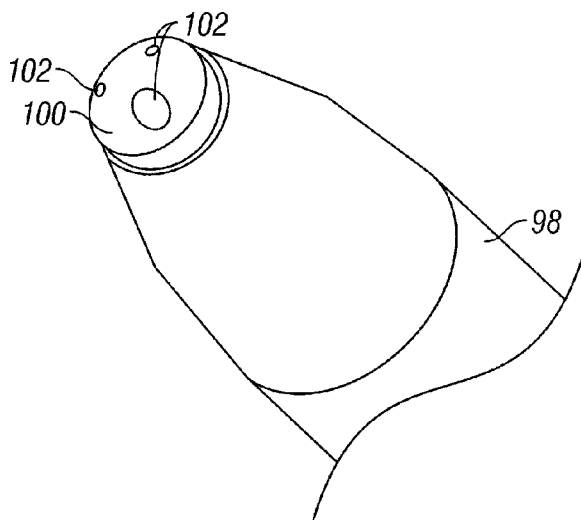

FIG. 5C

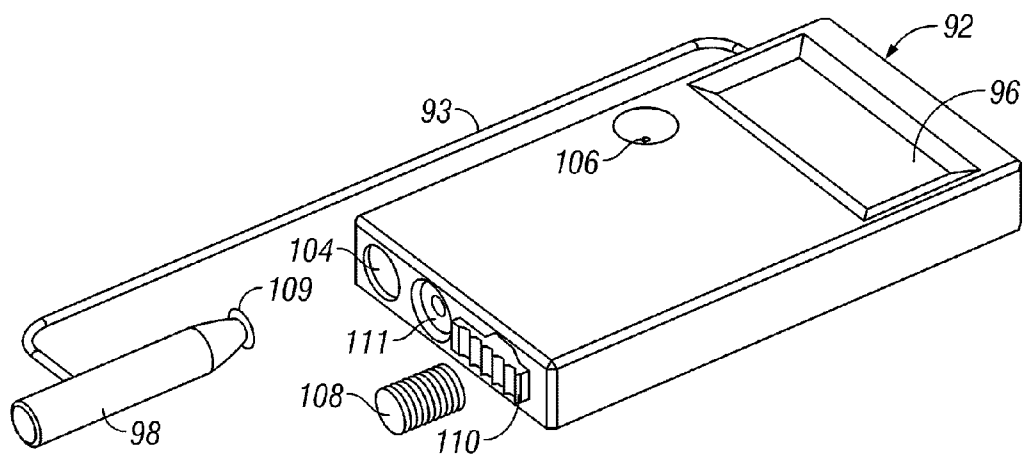

FIG. 5D

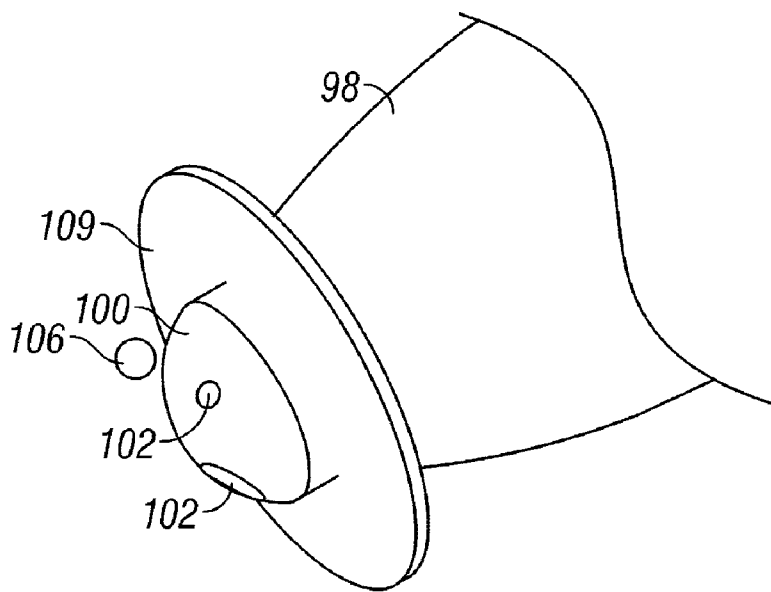

FIG. 5E

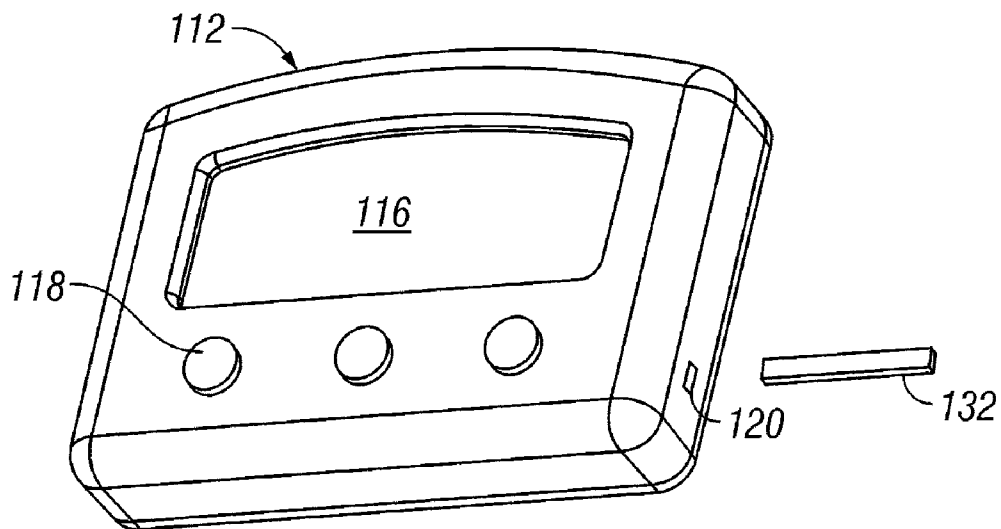

FIG. 6A

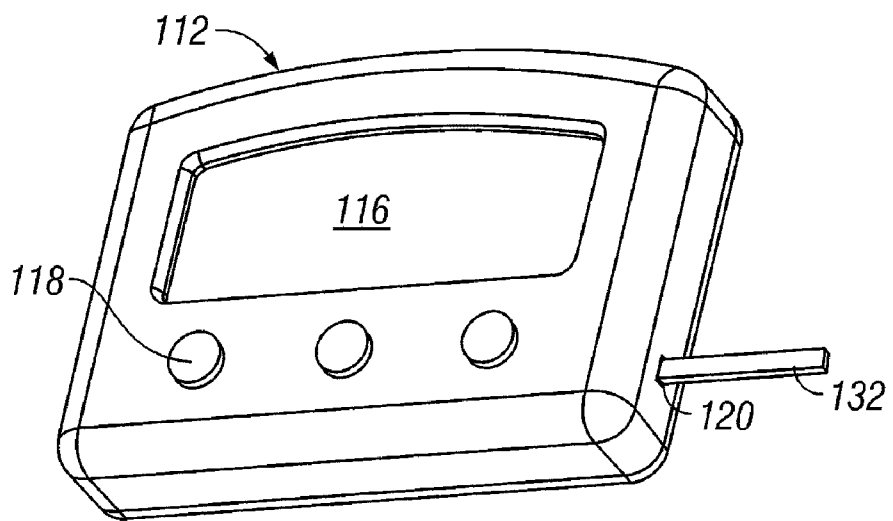

FIG. 6B

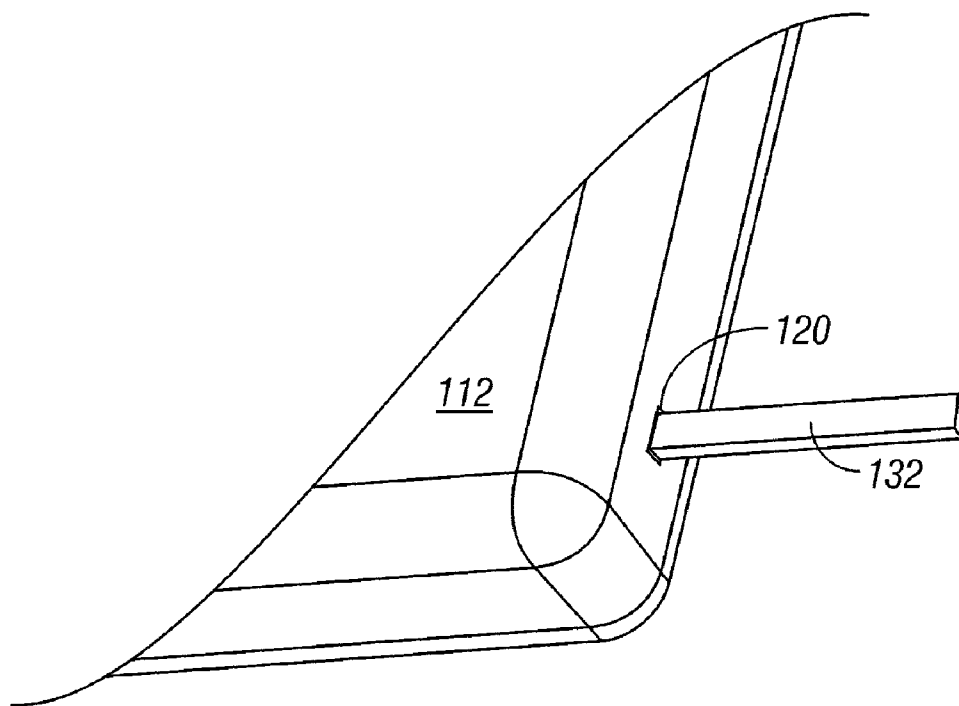

FIG. 6C

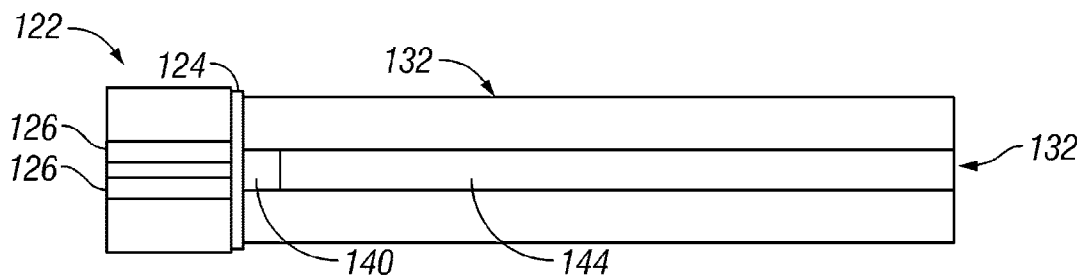

FIG. 6D

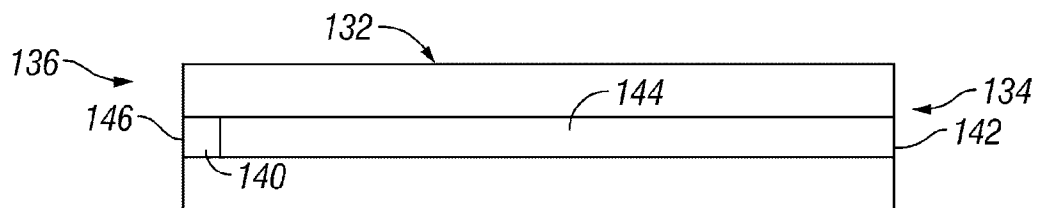

FIG. 6E

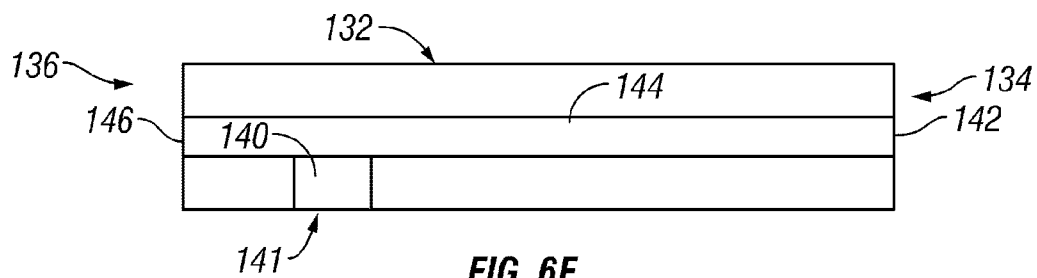

FIG. 6F

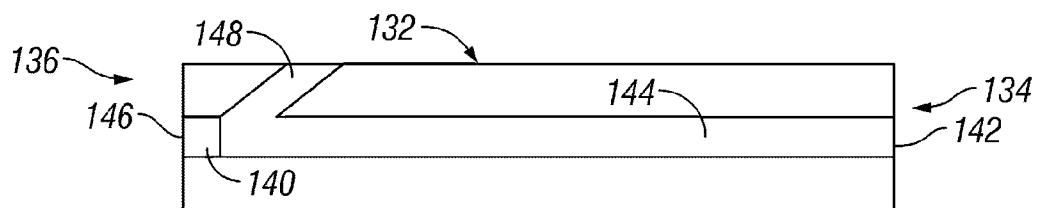
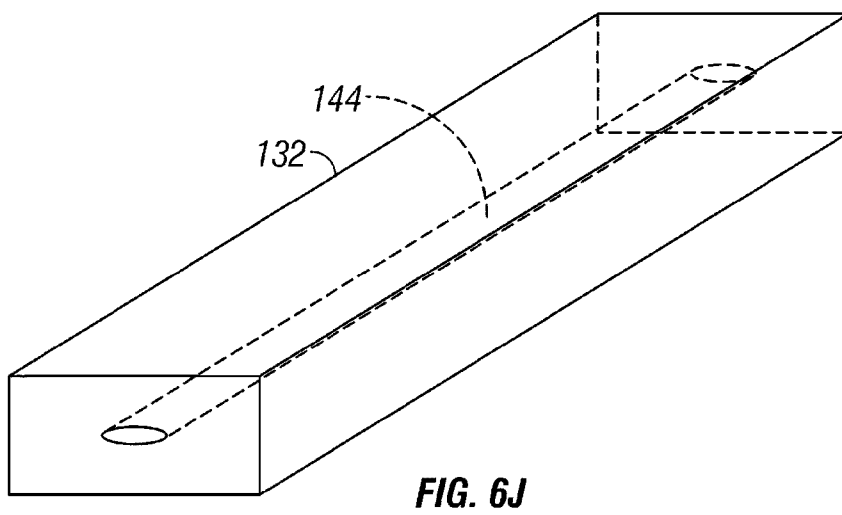
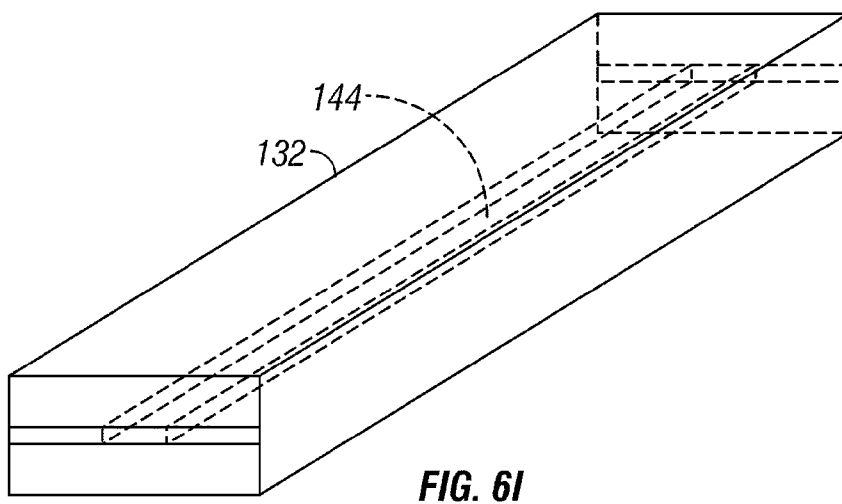
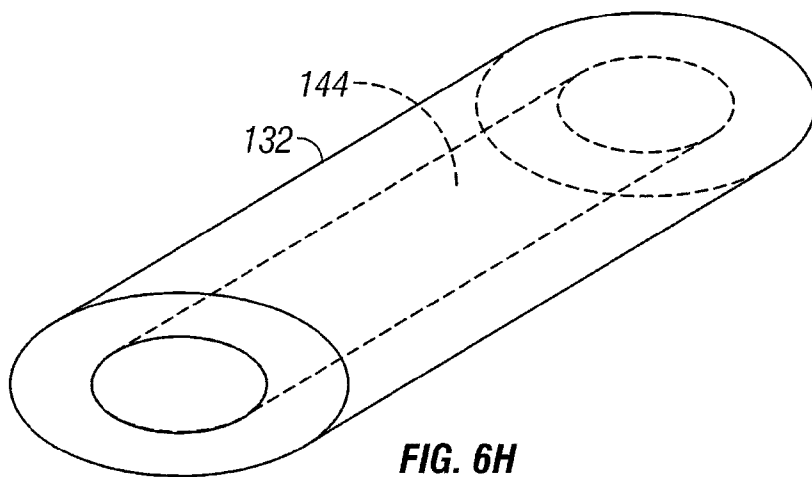

FIG. 6G



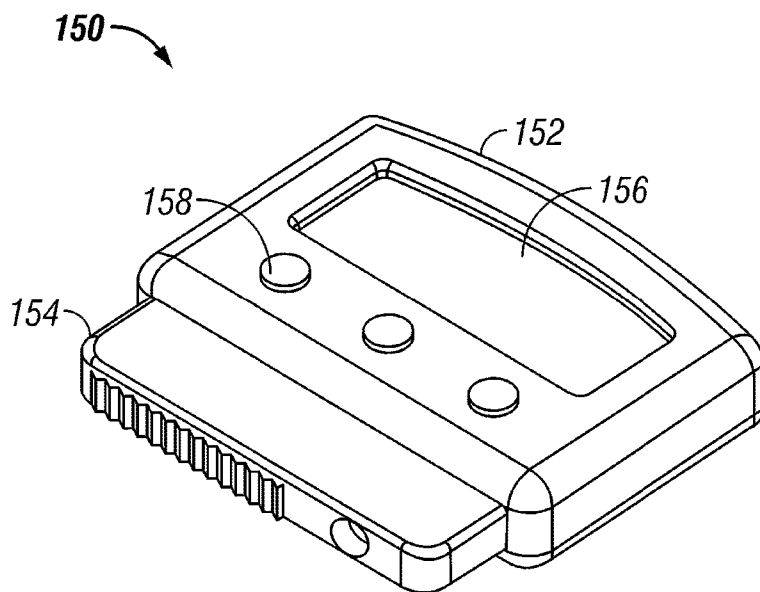

FIG. 7A

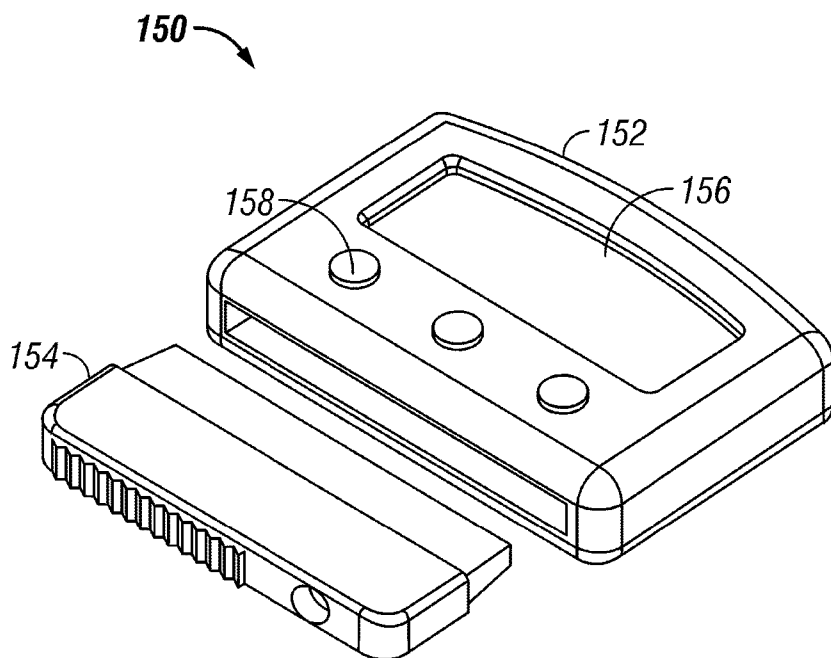

FIG. 7B

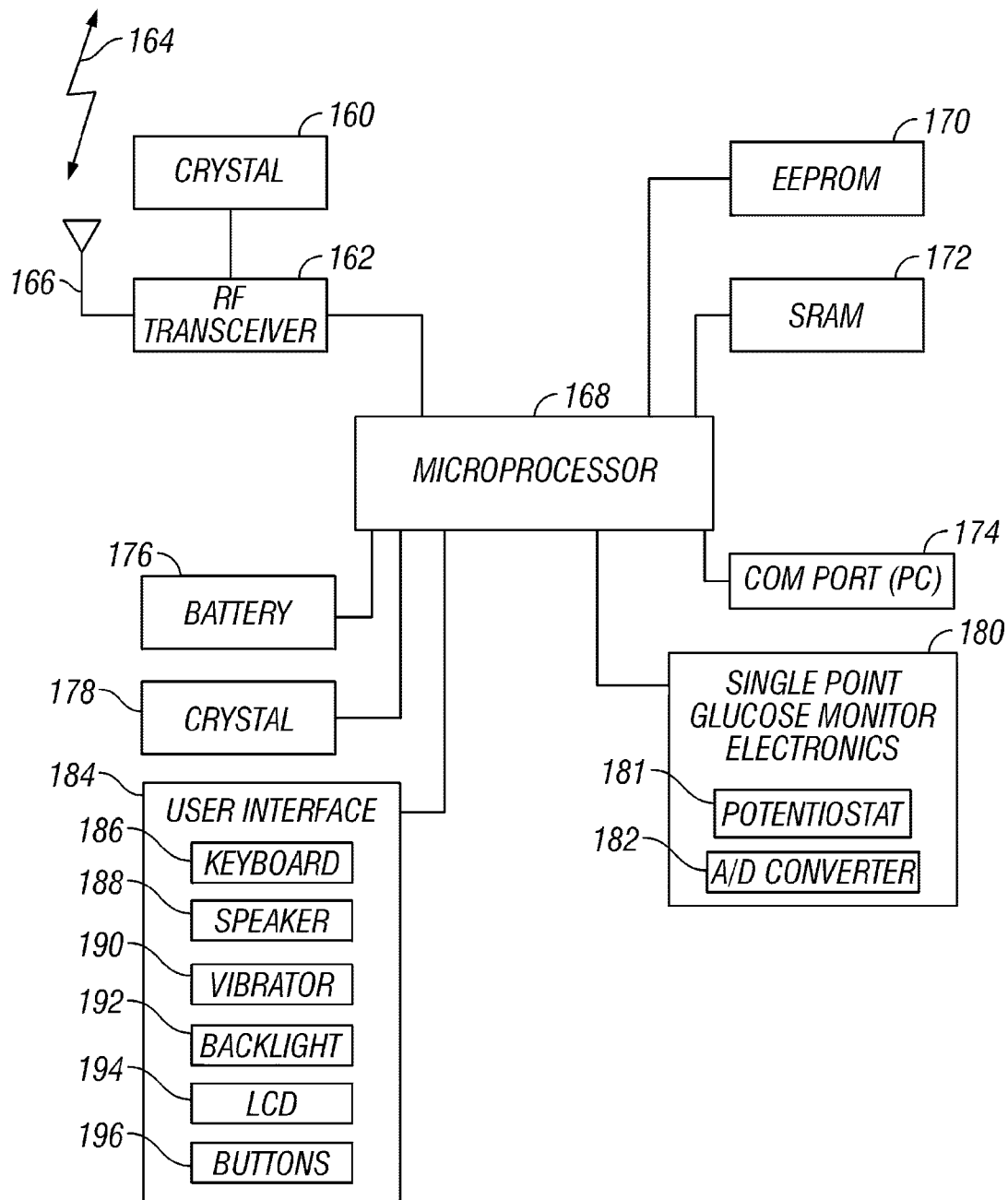

FIG. 8

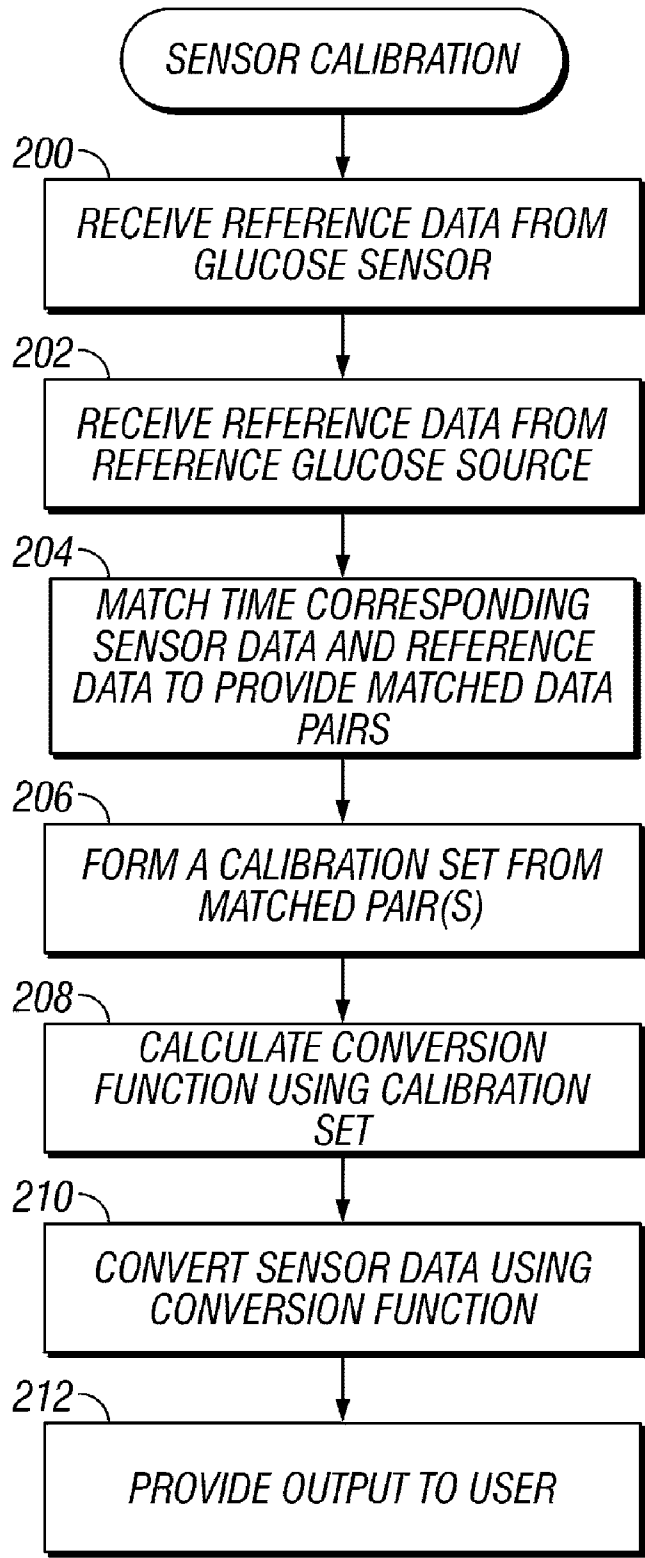

FIG. 9

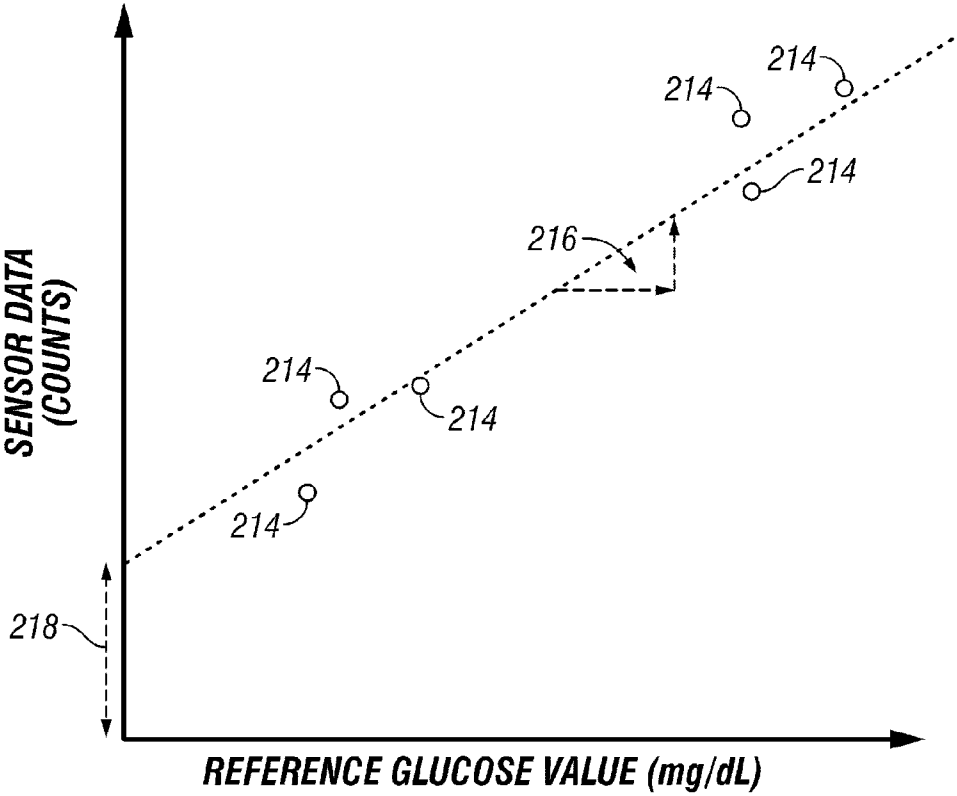

FIG. 10

INTEGRATED RECEIVER FOR CONTINUOUS ANALYTE SENSOR

CROSS-REFERENCE TO RELATED APPLICATIONS

[0001] This application is a continuation of U.S. application Ser. No. 12/182,008, filed Jul. 29, 2008, which is a division of U.S. application Ser. No. 10/991,966, filed Nov. 17, 2004, now U.S. Pat. No. 7,519,408, which claims the benefit of priority under 35 U.S.C. §119(e) to U.S. Provisional Application No. 60/523,840, filed Nov. 19, 2003, U.S. Provisional Application 60/587,787, filed Jul. 13, 2004, and U.S. Provisional Application No. 60/614,683, filed Sep. 30, 2004, each of which is incorporated by reference herein in its entirety, and each of which is hereby made a part of this specification.

FIELD OF THE INVENTION

[0002] The present invention relates generally to systems and methods for monitoring glucose in a host. Particularly, a device for continuous glucose sensing is provided with an integrated receiver for single point glucose measurement and subsequent calibration of the continuous glucose sensor within the device.

BACKGROUND OF THE INVENTION

[0003] A variety of continual and continuous glucose sensors have been developed for detecting and/or quantifying analytes in a biological fluid sample, for example, glucose sensors that continually or continuously measure glucose concentration in a host. Typically, these glucose sensors require a reference glucose measurement with which to calibrate the sensor-measured glucose values. Additionally, long-term implantable glucose sensors typically request regular updates of calibration, for example new reference glucose values every day, week, or month. Accordingly, a user has typically been required to keep track of and even stay close to (for example, carry) a device associated with the continuous glucose sensor that receives and processes data from the continuous glucose sensor. Additionally, a user has typically been required to carry a separate device that provides a reference glucose value for calibration of the continuous glucose sensor. Many times additional hardware, such as cables, test strips, and other auxiliary devices are necessary to connect, test, and otherwise use the devices. Therefore, the use of a continuous device can be cumbersome, particularly when the user is away from home.

[0004] Furthermore, continuous sensors have conventionally been calibrated using a reference glucose monitor that uses different measurement technology than that of the continuous sensor, which can increase the error within the calibrated sensor values. For example, an implantable glucose sensor that contains a membrane containing glucose oxidase is typically calibrated using self-monitoring blood glucose (SMBG) test strip-based measurement values. Unfortunately, such SMBG tests have an error of $\pm 20\%$ and additionally cannot be calibrated by the user. Furthermore, because the reference measurement device (for example, SMBG) is inde-

pendent from the continuous glucose sensor, the possibility of accuracy in reporting time of SMGB can be prone to human error.

SUMMARY OF THE INVENTION

[0005] A continuous glucose sensor that includes simpler or fewer components than prior art sensors, that is user friendly, that exhibits reduced error within the calibrated sensor values, and/or is less prone to human error is desirable.

[0006] Accordingly, in a first embodiment, a device for monitoring glucose concentration in a biological sample of a host is provided, the device comprising a continuous glucose sensor that produces a data stream indicative of a host's glucose concentration; an integrated receiver that receives the data stream from the continuous glucose sensor, wherein the integrated receiver comprises a microprocessor comprising programming to process the data stream received from glucose sensor; and a single point glucose monitor adapted to receive a biological sample from the host and measure the concentration of glucose in the sample; wherein the microprocessor further comprises programming to calibrate the data stream using the glucose concentration measured by the single point glucose monitor.

[0007] In an aspect of the first embodiment, the continuous glucose sensor comprises a sensing membrane comprising an enzyme; and an electrochemical cell that measures the glucose concentration.

[0008] In an aspect of the first embodiment, the single point glucose monitor comprises a sensing membrane comprising an enzyme; and an electrochemical cell that measures a concentration of glucose in the sample.

[0009] In an aspect of the first embodiment, the integrated receiver further comprises a user interface for displaying glucose concentration data from at least one of the continuous glucose sensor and the single point glucose monitor.

[0010] In a second embodiment, a method for calibrating a continuous glucose sensor in an integrated receiver is provided, the method comprising continually receiving a data stream in the integrated receiver from a continuous glucose sensor; measuring a glucose concentration of a biological sample using a single point glucose monitor integral with the integrated receiver; and calibrating the data stream within the integrated receiver using the glucose concentration measured by the single point glucose monitor.

[0011] In an aspect of the second embodiment, the method further comprises the step of displaying the glucose concentration measured by the single point glucose monitor.

[0012] In an aspect of the second embodiment, the method further comprises the step of displaying a calibrated data stream.

[0013] In a third embodiment, a device for calibrating continuous glucose sensor data is provided, the device comprising a single point glucose monitor adapted to measure a glucose concentration in a biological sample; a receiver for receiving a data stream from a continuous glucose sensor; a microprocessor comprising programming to calibrate the data stream from the continuous glucose sensor using the glucose concentration measured from the single point glucose monitor.

[0014] In an aspect of the third embodiment, the continuous glucose sensor comprises a sensing membrane comprising an enzyme; and an electrochemical cell that measures the glucose concentration.

[0015] In an aspect of the third embodiment, the single point glucose monitor comprises a sensing membrane comprising an enzyme; and an electrochemical cell that measures the glucose concentration in the biological sample.

[0016] In an aspect of the third embodiment, the device further comprises a user interface adapted to display glucose data from at least one of the continuous glucose sensor and the single point glucose monitor.

[0017] In an aspect of the third embodiment, the glucose monitor comprises a sensing region comprising a sensing membrane and at least two electrodes, wherein the sensing region is located within the integrated receiver.

[0018] In an aspect of the third embodiment, the integrated receiver comprises a removable cartridge, and wherein the sensing region is located within the removable cartridge.

[0019] In an aspect of the third embodiment, the integrated receiver comprises a housing, and wherein the glucose monitor comprises a sensing region movably mounted to the integrated receiver housing.

[0020] In an aspect of the third embodiment, the device further comprises a stylus movably mounted to the integrated receiver housing, and wherein the sensing region is located on the stylus.

[0021] In an aspect of the third embodiment, the device further comprises a receiving chamber located within the integrated receiver housing, and wherein the stylus is received within the receiving chamber for storage.

[0022] In an aspect of the third embodiment, the device further comprises a sterile solution chamber located at an end of the receiving chamber such that the sensing region is operably associated with the sterile solution chamber when the stylus is received within the receiving chamber for storage.

[0023] In an aspect of the third embodiment, the device further comprises a sterile solution port configured for refilling the sterile solution chamber with a sterile solution.

[0024] In an aspect of the third embodiment, the device further comprises a dispensing chamber located in the integrated receiver housing, the dispensing chamber adapted to dispense at least one disposable bioprotective film onto the sensing region.

[0025] In an aspect of the third embodiment, the device further comprises a storage chamber located in the integrated receiver housing, the storage chamber adapted to store the disposable bioprotective film.

[0026] In an aspect of the third embodiment, the device further comprises a shuttle mechanism located on the integrated receiver housing, the shuttle mechanism adapted to load the disposable bioprotective film into the dispensing chamber.

[0027] In an aspect of the third embodiment, the device further comprises at least one bioprotective film that is adapted to stretch or stick onto the sensing region to protect the sensing region from damage, clogging, or contamination from a biological fluid.

[0028] In an aspect of the third embodiment, the bioprotective film further comprises a sensing membrane comprising an enzyme.

[0029] In an aspect of the third embodiment, the sensing region comprises a sensing membrane and at least two electrodes, wherein the sensing membrane is disposed over the electrodes adapted for measuring a glucose concentration in a biological sample.

[0030] In an aspect of the third embodiment, the single point glucose monitor comprises a sensor port that houses a sensing region adapted for measuring a glucose concentration in the biological sample.

[0031] In an aspect of the third embodiment, the device further comprises a disposable capillary tube, wherein the capillary tube is configured to create a capillary action capable of drawing a liquid biological sample from a first end of the tube to a second end of the tube.

[0032] In an aspect of the third embodiment, the capillary tube comprises a filter configured to permit passage of glucose, but to filter or block passage of an undesired species or a contaminating species in the biological sample.

[0033] In an aspect of the third embodiment, the capillary tube further comprises a vent configured to allow displaced air within the capillary tube to escape therefrom.

[0034] In an aspect of the third embodiment, the sensor port comprises a cover adapted for protecting the sensing region.

[0035] In an aspect of the third embodiment, the disposable capillary tube comprises a sensing membrane, wherein the sensing membrane comprises a resistance domain, an enzyme domain, an interference domain, and an electrolyte domain.

[0036] In an aspect of the third embodiment, the single point glucose monitor and the receiver are detachably connected to each other.

[0037] In an aspect of the third embodiment, the single point glucose monitor and the receiver each comprise at least one contact adapted for operable connection when detachably connected to each other.

[0038] In an aspect of the third embodiment, the microprocessor is located within the receiver.

[0039] In an aspect of the third embodiment, the device further comprises a microprocessor located within the single point glucose monitor, wherein the microprocessor is adapted for communication between the single point glucose monitor and the receiver when the single point glucose monitor contact and the receiver contact are operably connected.

[0040] In a fourth embodiment, a device for monitoring a glucose concentration in a biological sample in a host is provided, the device comprising a continuous glucose sensor configured to produce a data stream indicative of a glucose concentration in a biological sample of a host, wherein the glucose sensor comprises a sensing membrane comprising a catalyst, wherein the membrane is operably associated with at least two electrodes that are operably connected to an electrical circuit adapted for continuous glucose sensing; a single point glucose monitor configured to produce a glucose concentration measurement from a biological sample obtained from a host, wherein the glucose monitor comprises a sensing membrane comprising a catalyst, wherein the membrane is operably associated with at least two electrodes that are operably connected to an electrical circuit adapted for measuring the glucose concentration in the biological sample; a receiver integral with the single point glucose monitor adapted to receive a data stream from the continuous glucose sensor; and a microprocessor integral with the single point glucose monitor that comprises programming to calibrate the data stream from the continuous glucose sensor using the glucose concentration measurement from the single point glucose monitor.

BRIEF DESCRIPTION OF THE DRAWINGS

[0041] FIG. 1 is a block diagram that illustrates an integrated receiver in one embodiment in wireless communication with a continuous glucose sensor.

[0042] FIG. 2A is an exploded perspective view of one exemplary embodiment of a continuous glucose sensor.

[0043] FIG. 2B is an expanded view of an alternative exemplary embodiment of a continuous glucose sensor, illustrating the in vivo portion of the sensor.

[0044] FIG. 3 is a block diagram that illustrates the continuous glucose sensor electronics in one embodiment.

[0045] FIG. 4A is a perspective view of an integrated receiver in one embodiment showing a single point glucose monitor in its closed position.

[0046] FIG. 4B is an exploded perspective view of the integrated receiver of FIG. 4A showing the single point glucose monitor with a cover removed.

[0047] FIG. 5A is a perspective view of an integrated receiver housing in another embodiment, showing a single point glucose monitor including a stylus movably mounted to the integrated receiver, wherein the stylus is shown in a storage position.

[0048] FIG. 5B is a perspective view of the integrated housing of FIG. 5A, showing the stylus in a testing position.

[0049] FIG. 5C is a perspective view of a portion of the stylus of FIG. 5A, showing the sensing region.

[0050] FIG. 5D is a perspective view of the integrated receiver housing of FIG. 5A, showing the stylus loaded with a disposable film, and in its testing position.

[0051] FIG. 5E is a perspective view of a portion of the stylus of FIG. 5A, showing the sensing region with a disposable film stretched and/or disposed thereon for receiving a biological sample.

[0052] FIG. 6A is a perspective view of an integrated receiver in yet another embodiment, including a single point glucose monitor and a disposable capillary tube for transferring a biological sample to a sensing region on the monitor.

[0053] FIG. 6B is a perspective view of the integrated receiver of FIG. 6A, showing the disposable capillary tube inserted into the single point glucose monitor to transfer the biological sample to a sensing region on the single point glucose monitor.

[0054] FIG. 6C is an expanded perspective view of a portion of the integrated receiver of FIG. 6A, showing the capillary tube inserted into the single point glucose monitor.

[0055] FIG. 6D is a schematic cross-sectional view of a capillary tube and a portion of the integrated receiver of FIG. 6A, illustrating the capillary tube in contact with the sensing membrane such that glucose from the biological sample can be measured by electrodes on the sensing region.

[0056] FIG. 6E is a schematic cross-sectional view of the capillary tube of FIG. 6A, illustrating an embodiment wherein a filter is located on one end.

[0057] FIG. 6F is a schematic cross-sectional view of the capillary tube of FIG. 6A, illustrating an embodiment wherein a filter is disposed within a wall of the capillary tube.

[0058] FIG. 6G is a schematic cross-sectional view of the capillary tube of FIG. 6A, illustrating an embodiment wherein a vent extends from the capillary tube.

[0059] FIG. 6H is a schematic illustration of one embodiment, wherein the capillary tube is round in shape with an inner capillary tube that is also round in shape.

[0060] FIG. 6I is a schematic illustration of one embodiment, wherein the capillary tube is rectangular in shape with an inner capillary tube that is formed therein.

[0061] FIG. 6J is a schematic illustration of one embodiment, wherein the capillary tube is rectangular in shape an inner capillary tube has a rounded structure.

[0062] FIG. 7A is a perspective view of an integrated receiver in yet another embodiment, wherein the single point glucose monitor is detachably connected to the receiver to form a modular configuration, shown in its attached state.

[0063] FIG. 7B is a perspective view of the integrated receiver of FIG. 7A, shown in its detached state.

[0064] FIG. 8 is a block diagram that illustrates integrated receiver electronics in one embodiment.

[0065] FIG. 9 is a flow chart that illustrates the process of initial calibration of the continuous glucose sensor and data output of the integrated receiver in one embodiment.

[0066] FIG. 10 is a graph that illustrates one exemplary embodiment of a regression performed on a calibration set to create a conversion function.

DETAILED DESCRIPTION OF THE PREFERRED EMBODIMENT

[0067] The following description and examples illustrate some exemplary embodiments of the disclosed invention in detail. Those of skill in the art will recognize that there are numerous variations and modifications of this invention that are encompassed by its scope. Accordingly, the description of a certain exemplary embodiment should not be deemed to limit the scope of the present invention.

DEFINITIONS

[0068] In order to facilitate an understanding of the preferred embodiments, a number of terms are defined below.

[0069] The term “continuous glucose sensor,” as used herein, is a broad term and are used in its ordinary sense, including, without limitation, a device that continuously or continually measures glucose concentration, for example, at time intervals ranging from fractions of a second up to, for example, 1, 2, or 5 minutes, or longer. It should be understood that continuous glucose sensors can continually or continuously measure glucose concentration without requiring user initiation and/or interaction for each measurement, such as described with reference to U.S. Pat. No. 6,001,067, for example.

[0070] The phrase “continuous glucose sensing,” as used herein, is a broad term and is used in its ordinary sense, including, without limitation, the period in which monitoring of plasma glucose concentration is continuously or continually performed, for example, at time intervals ranging from fractions of a second up to, for example, 1, 2, or 5 minutes, or longer.

[0071] The term “single point glucose monitor,” as used herein, is a broad term and is used in its ordinary sense, including, without limitation, a device that can be used to measure a glucose concentration within a host at a single point in time, for example, some embodiments utilize a small volume in vitro glucose monitor that includes an enzyme membrane such as described with reference to U.S. Pat. No. 4,994,167 and U.S. Pat. No. 4,757,022. It should be understood that single point glucose monitors can measure multiple samples (for example, blood or interstitial fluid); however only one sample is measured at a time and typically requires some user initiation and/or interaction.

[0072] The term “capillary action,” as used herein, is a broad term and is used in its ordinary sense, including, without limitation, the phenomenon of a liquid, such as water or blood, spontaneously creeping up a thin tube or fiber due to adhesive or cohesive forces or surface tension.

[0073] The term “biological sample,” as used herein, is a broad term and is used in its ordinary sense, including, without limitation, sample of a host body, for example blood, interstitial fluid, spinal fluid, saliva, urine, tears, sweat, or the like.

[0074] The term “host,” as used herein, is a broad term and is used in its ordinary sense, including, without limitation, mammals such as humans.

[0075] The term “biointerface membrane,” as used herein, is a broad term and is used in its ordinary sense, including, without limitation, a permeable or semi-permeable membrane that can include two or more domains and is typically constructed of materials of a few microns thickness or more, which can be placed over the sensing region to keep host cells (for example, macrophages) from gaining proximity to, and thereby damaging the sensing membrane or forming a barrier cell layer and interfering with the transport of glucose across the tissue-device interface.

[0076] The term “sensing membrane,” as used herein, is a broad term and is used in its ordinary sense, including, without limitation, a permeable or semi-permeable membrane that can be comprised of two or more domains and is typically constructed of materials of a few microns thickness or more, which are permeable to oxygen and are optionally permeable to glucose. In one example, the sensing membrane comprises an immobilized glucose oxidase enzyme, which enables an electrochemical reaction to occur to measure a concentration of glucose.

[0077] The term “domain,” as used herein is a broad term and is used in its ordinary sense, including, without limitation, regions of a membrane that can be layers, uniform or non-uniform gradients (for example, anisotropic), functional aspects of a material, or provided as portions of the membrane.

[0078] As used herein, the term “copolymer,” as used herein, is a broad term and is used in its ordinary sense, including, without limitation, polymers having two or more different repeat units and includes copolymers, terpolymers, tetrapolymers, etc.

[0079] The term “sensing region,” as used herein, is a broad term and is used in its ordinary sense, including, without limitation, the region of a monitoring device responsible for the detection of glucose. In one embodiment, the sensing region generally comprises a non-conductive body, a working electrode (anode), a reference electrode and a counter electrode (cathode) passing through and secured within the body forming an electrochemically reactive surface at one location on the body and an electronic connection at another location on the body, and a sensing membrane affixed to the body and covering the electrochemically reactive surface. During general operation of the sensor a biological sample (for example, blood or interstitial fluid) or a portion thereof contacts (for example, directly or after passage through one or more domains of the sensing membrane) an enzyme (for example, glucose oxidase); the reaction of the biological sample (or portion thereof) results in the formation of reaction products that allow a determination of the glucose level in the biological sample.

[0080] The term “electrochemically reactive surface,” as used herein, is a broad term and is used in its ordinary sense, including, without limitation, the surface of an electrode where an electrochemical reaction takes place. In the case of an electrochemical glucose sensor, hydrogen peroxide produced by an enzyme catalyzed reaction of the glucose being

detected reacts at a working electrode creating a measurable electronic current (for example, detection of glucose utilizing glucose oxidase produces H_2O_2 as a by product, H_2O_2 reacts with the surface of the working electrode producing two protons ($2H^+$), two electrons ($2e^-$) and one molecule of oxygen (O_2) which produces the electronic current being detected). In the case of the counter electrode, a reducible species (for example, O_2) is reduced at the electrode surface in order to balance the current being generated by the working electrode.

[0081] The term “electrochemical cell,” as used herein, is a broad term and is used in its ordinary sense, including, without limitation, a device in which chemical energy is converted to electrical energy. Such a cell typically consists of two or more electrodes held apart from each other and in contact with an electrolyte solution. Connection of the electrodes to a source of direct electric current renders one of them negatively charged and the other positively charged. Positive ions in the electrolyte migrate to the negative electrode (cathode) and there combine with one or more electrons, losing part or all of their charge and becoming new ions having lower charge or neutral atoms or molecules; at the same time, negative ions migrate to the positive electrode (anode) and transfer one or more electrons to it, also becoming new ions or neutral particles. The overall effect of the two processes is the transfer of electrons from the negative ions to the positive ions, a chemical reaction.

[0082] The term “proximal” as used herein, is a broad term and is used in its ordinary sense, including, without limitation, near to a point of reference such as an origin or a point of attachment. For example, in some embodiments of a sensing membrane that covers an electrochemically reactive surface, the electrolyte domain is located more proximal to the electrochemically reactive surface than the interference domain.

[0083] The term “distal” as used herein, is a broad term and is used in its ordinary sense, including, without limitation, spaced relatively far from a point of reference, such as an origin or a point of attachment. For example, in some embodiments of a sensing membrane that covers an electrochemically reactive surface, a resistance domain is located more distal to the electrochemically reactive surfaces than the enzyme domain.

[0084] The term “substantially” as used herein, is a broad term and is used in its ordinary sense, including, without limitation, being largely but not necessarily wholly that which is specified.

[0085] The terms “microprocessor” and “processor,” as used herein, are broad terms and are used in their ordinary sense, including, without limitation, a computer system or state machine designed to perform arithmetic and logic operations using logic circuitry that responds to and processes the basic instructions that drive a computer.

[0086] The term “EEPROM,” as used herein, is a broad term and is used in its ordinary sense, including, without limitation, electrically erasable programmable read-only memory, which is user-modifiable read-only memory (ROM) that can be erased and reprogrammed (for example, written to) repeatedly through the application of higher than normal electrical voltage.

[0087] The term “SRAM,” as used herein, is a broad term and is used in its ordinary sense, including, without limitation, static random access memory (RAM) that retains data bits in its memory as long as power is being supplied.

[0088] The term “A/D Converter,” as used herein, is a broad term and is used in its ordinary sense, including, without limitation, hardware and/or software that converts analog electrical signals into corresponding digital signals.

[0089] The term “RF transceiver,” as used herein, is a broad term and is used in its ordinary sense, including, without limitation, a radio frequency transmitter and/or receiver for transmitting and/or receiving signals.

[0090] The terms “raw data stream” and “data stream,” as used herein, are broad terms and are used in their ordinary sense, including, without limitation, an analog or digital signal directly related to the measured glucose from the glucose sensor. In one example, the raw data stream is digital data in “counts” converted by an A/D converter from an analog signal (for example, voltage or amps) representative of a glucose concentration. The terms broadly encompass a plurality of time spaced data points from a substantially continuous glucose sensor, which comprises individual measurements taken at time intervals ranging from fractions of a second up to, for example, 1, 2, or 5 minutes or longer.

[0091] The term “counts,” as used herein, is a broad term and is used in its ordinary sense, including, without limitation, a unit of measurement of a digital signal. In one example, a raw data stream measured in counts is directly related to a voltage (for example, converted by an A/D converter), which is directly related to current from the working electrode. In another example, counter electrode voltage measured in counts is directly related to a voltage.

[0092] The term “electronic circuitry,” as used herein, is a broad term and is used in its ordinary sense, including, without limitation, the components (for example, hardware and/or software) of a device configured to process data. In the case of a glucose-measuring device, the data includes biological information obtained by a sensor regarding a particular glucose in a biological fluid, thereby providing data regarding the amount of that glucose in the fluid. U.S. Pat. Nos. 4,757,022, 5,497,772 and 4,787,398, which are hereby incorporated by reference, describe suitable electronic circuits that can be utilized with devices of the preferred embodiments.

[0093] The term “potentiostat,” as used herein, is a broad term and is used in its ordinary sense, including, but not limited to, an electrical system that applies a potential between the working and reference electrodes of a two- or three-electrode cell at a preset value and measures the current flow through the working electrode. The potentiostat forces whatever current is necessary to flow between the working and reference (2 electrode) or counter (3 electrode) electrodes to keep the desired potential, as long as the needed cell voltage and current do not exceed the compliance limits of the potentiostat.

[0094] The term “electrical potential,” as used herein, is a broad term and is used in its ordinary sense, including, without limitation, the electrical potential difference between two points in a circuit which is the cause of the flow of a current.

[0095] The terms “operably connected” and “operably linked,” as used herein, are broad terms and are used in their ordinary sense, including, without limitation, one or more components being linked to another component(s) in a manner that allows transmission of signals between the components. For example, one or more electrodes can be used to detect the amount of glucose in a sample and convert that information into a signal. The signal can then be transmitted to an electronic circuit. In this case, the electrode is “operably

linked” to the electronic circuit. These terms are broad enough to include wireless connectivity.

[0096] The term “linear regression,” as used herein, is a broad term and is used in its ordinary sense, including, without limitation, finding a line in which a set of data has a minimal measurement from that line. Byproducts of this algorithm include a slope, a y-intercept, and an R-Squared value that determine how well the measurement data fits the line.

[0097] The term “non-linear regression,” as used herein, is a broad term and is used in its ordinary sense, including, without limitation, fitting a set of data to describe the relationship between a response variable and one or more explanatory variables in a non-linear fashion.

Overview

[0098] FIG. 1 is a perspective view of a device in one embodiment including a continuous glucose sensor and an integrated receiver that has a single point glucose monitor thereon. The continuous glucose sensor **10** continuously measures glucose concentration in a host to provide a data stream representative of the host’s glucose concentration, such as described in more detail below with reference to FIGS. 2 and 3. In general, the integrated receiver **12** includes a single point glucose monitor **14**, electronic circuitry that processes data from the continuous glucose sensor **10** and the single point glucose monitor **14**, and a user interface **16** that displays glucose data to a user, all of which are described in more detail with reference to FIGS. 4 to 10. Wireless transmissions **18** allow communication between the glucose sensor **10** and the integrated receiver **12**, for example, so that the integrated receiver **12** can receive a data stream from the continuous glucose sensor **10**.

Continuous Glucose Sensor

[0099] The preferred embodiments provide a continuous glucose sensor that measures a concentration of glucose or a substance indicative of the concentration or presence of the glucose. In some embodiments, the glucose sensor is an invasive, minimally-invasive, or non-invasive device, for example a subcutaneous, transdermal, or intravascular device. In some embodiments, the device can analyze a plurality of intermittent biological samples. The glucose sensor can use any method of glucose-measurement, including enzymatic, chemical, physical, electrochemical, spectrophotometric, polarimetric, calorimetric, radiometric, or the like. In alternative embodiments, the sensor can be any sensor capable of determining the level of an analyte in the body, for example oxygen, lactase, hormones, cholesterol, medicaments, viruses, or the like.

[0100] The glucose sensor uses any known method to provide an output signal indicative of the concentration of the glucose. The output signal is typically a raw data stream that is used to provide a useful value of the measured glucose concentration to a patient or doctor, for example.

[0101] One exemplary embodiment is described in detail below, which utilizes an implantable glucose sensor. However, it should be understood that the devices and methods described herein can be applied to any device capable of continually or continuously detecting a concentration of analyte of interest and providing an output signal that represents the concentration of that analyte.

[0102] FIG. 2A is an exploded perspective view of one exemplary embodiment of a continuous glucose sensor **10a**.

In this embodiment, the sensor is preferably wholly implanted into the subcutaneous tissue of a host, such as described in co-pending patent application Ser. No. 10/885,476 filed Jul. 6, 2004 and entitled "SYSTEMS AND METHODS FOR MANUFACTURE OF AN ANALYTE-MEASURING DEVICE INCLUDING A MEMBRANE SYSTEM"; co-pending U.S. patent application Ser. No. 10/838,912 filed May 3, 2004 and entitled, "IMPLANTABLE ANALYTE SENSOR"; U.S. patent application Ser. No. 10/789,359 filed Feb. 26, 2004 and entitled, "INTEGRATED DELIVERY DEVICE FOR A CONTINUOUS GLUCOSE SENSOR"; U.S. application Ser. No. 10/646,333 filed Aug. 22, 2003 entitled, "OPTIMIZED SENSOR GEOMETRY FOR AN IMPLANTABLE GLUCOSE SENSOR"; U.S. application Ser. No. 10/633,367 filed Aug. 1, 2003 entitled, "SYSTEM AND METHODS FOR PROCESSING ANALYTE SENSOR DATA"; and U.S. Pat. No. 6,001,067 issued Dec. 14, 1999 and entitled "DEVICE AND METHOD FOR DETERMINING ANALYTE LEVELS", each of which are incorporated herein by reference in their entirety. In this exemplary embodiment, a body **20** and a sensing region **21** house the electrodes **22** and sensor electronics (FIG. 3). The three electrodes **22** are operably connected to the sensor electronics (FIG. 3) and are covered by a sensing membrane **23** and a biointerface membrane **24**, which are attached by a clip **25**.

[0103] In one embodiment, the three electrodes **22** include a platinum working electrode, a platinum counter electrode, and a silver/silver chloride reference electrode. The top ends of the electrodes are in contact with an electrolyte phase (not shown), which is a free-flowing fluid phase disposed between the sensing membrane **23** and the electrodes **22**. The sensing membrane **23** includes an enzyme, for example, glucose oxidase, and covers the electrolyte phase. The biointerface membrane **24** covers the sensing membrane **23** and serves, at least in part, to protect the sensor **10a** from external forces that can result in environmental stress cracking of the sensing membrane **23**. Copending U.S. patent application Ser. No. 10/647,065, entitled, "POROUS MEMBRANES FOR USE WITH IMPLANTABLE DEVICES," describes a biointerface membrane that can be used in conjunction with the preferred embodiments, and is incorporated herein by reference in its entirety.

[0104] In one embodiment, the biointerface membrane **24** generally includes a cell disruptive domain most distal from the electrochemically reactive surfaces and a cell impermeable domain less distal from the electrochemically reactive surfaces than the cell disruptive domain. The cell disruptive domain is preferably designed to support tissue ingrowth, disrupt contractile forces typically found in a foreign body response, encourage vascularity within the membrane, and disrupt the formation of a barrier cell layer. The cell impermeable domain is preferably resistant to cellular attachment, impermeable to cells, and composed of a biostable material.

[0105] In one embodiment, the sensing membrane **23** generally provides one or more of the following functions: 1) protection of the exposed electrode surface from the biological environment, 2) diffusion resistance (limitation) of the analyte, 3) a catalyst for enabling an enzymatic reaction, 4) limitation or blocking of interfering species, and 5) hydrophilicity at the electrochemically reactive surfaces of the sensor interface, such as described in co-pending U.S. patent application Ser. No. 10/838,912, filed May 3, 2004 and entitled "IMPLANTABLE ANALYTE SENSOR," which is incorpo-

rated herein by reference in its entirety. Accordingly, the sensing membrane **23** preferably includes a plurality of domains or layers, for example, an electrolyte domain, an interference domain, an enzyme domain (for example, glucose oxidase), a resistance domain, and can additionally include an oxygen domain (not shown), and/or a bioprotective domain (not shown), such as described in more detail in the above-cited U.S. patent application Ser. No. 10/838,912. However, it is understood that a sensing membrane modified for other devices, for example, by including fewer or additional domains is within the scope of the preferred embodiments.

[0106] In some embodiments, the domains of the biointerface and sensing membranes are formed from materials such as silicone, polytetrafluoroethylene, polyethylene-co-tetrafluoroethylene, polyolefin, polyester, polycarbonate, biostable polytetrafluoroethylene, homopolymers, copolymers, terpolymers of polyurethanes, polypropylene (PP), polyvinylchloride (PVC), polyvinylidene fluoride (PVDF), polybutylene terephthalate (PBT), polymethylmethacrylate (PMMA), polyether ether ketone (PEEK), polyurethanes, cellulosic polymers, polysulfones and block copolymers thereof including, for example, di-block, tri-block, alternating, random and graft copolymers. Co-pending U.S. patent application Ser. No. 10/838,912, which is incorporated herein by reference in its entirety, describes biointerface and sensing membrane configurations and materials that can be applied to the preferred embodiments.

[0107] In the illustrated embodiment, the counter electrode is provided to balance the current generated by the species being measured at the working electrode. In the case of a glucose oxidase based glucose sensor, the species being measured at the working electrode is H_2O_2 . Glucose oxidase catalyzes the conversion of oxygen and glucose to hydrogen peroxide and gluconate according to the following reaction:

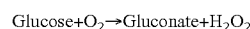

[0108] The change in H_2O_2 can be monitored to determine glucose concentration because for each glucose molecule metabolized, there is a proportional change in the product H_2O_2 . Oxidation of H_2O_2 by the working electrode is balanced by reduction of ambient oxygen, enzyme generated H_2O_2 , or other reducible species at the counter electrode. The H_2O_2 produced from the glucose oxidase reaction further reacts at the surface of working electrode and produces two protons ($2H^+$), two electrons ($2e^-$), and one oxygen molecule (O_2).

[0109] In one embodiment, a potentiostat is employed to monitor the electrochemical reaction at the electrochemical cell. The potentiostat applies a constant potential to the working and reference electrodes to determine a current value. The current that is produced at the working electrode (and flows through the circuitry to the counter electrode) is substantially proportional to the amount of H_2O_2 that diffuses to the working electrode. Accordingly, a raw signal can be produced that is representative of the concentration of glucose in the user's body, and therefore can be utilized to estimate a meaningful glucose value, such as described herein.

[0110] FIG. 2B is an expanded view of an alternative exemplary embodiment of a continuous glucose sensor, illustrating the in vivo portion of the sensor. Co-pending U.S. Provisional Application 60/587,787, filed Jul. 13, 2004 and U.S. Provisional Application 60/614,683, filed Sep. 30, 2004, describe systems and methods suitable for the transcutaneous sensor

of the illustrated embodiment; however, one skilled in the art appreciates a variety of transcutaneous sensors that can benefit from the integrated receiver of the preferred embodiments.

[0111] In this embodiment, the in vivo portion of the sensor **10b** is the portion adapted for insertion under the host's skin, while an ex vivo portion of the sensor **10b** is the portion that remains above the host's skin after sensor insertion and operably connects to an electronics unit (not shown). The sensor **10b** two or more electrodes: a working electrode **26** and at least one additional electrode **28**, which can function as a counter and/or reference electrode, hereinafter referred to as the reference electrode. Each electrode is formed from a fine wire, with a diameter in the range of 0.001 to 0.010 inches, for example, and can be formed from plated wire or bulk material.

[0112] In one embodiment, the working electrode **26** comprises a wire formed from a conductive material, such as platinum, palladium, graphite, gold, carbon, conductive polymer, or the like. The working electrode **26** is configured and arranged to measure the concentration of an analyte. The working electrode **20** is covered with an insulating material, for example a non-conductive polymer. Dip-coating, spray-coating, or other coating or deposition techniques can be used to deposit the insulating material on the working electrode, for example. In one preferred embodiment, the insulating material comprises Parylene, which can be an advantageous conformal coating for its strength, lubricity, and electrical insulation properties, however, a variety of other insulating materials can be used, for example, fluorinated polymers, polyethyleneterephthalate, polyurethane, polyimide, or the like.

[0113] The reference electrode **28**, which can function as a reference electrode alone, or as a dual reference and counter electrode, is formed from silver, Silver/Silver chloride, or the like. In one embodiment, the reference electrode **28** is formed from a flat wire with rounded edges in order to decrease sharp edges and increase host comfort. Preferably, the reference electrode **28** is juxtapositioned and/or twisted with or around the working electrode **26**; however other configurations are also possible. In some embodiments, the reference electrode **28** is helically wound around the working electrode **26** (see FIG. 2B). The assembly of wires is then optionally coated together with an insulating material, similar to that described above, in order to provide an insulating attachment. Some portion of the coated assembly structure is then stripped, for example using an excimer laser, chemical etching, or the like, to expose the necessary electroactive surfaces. In one implementation, a window **28** is formed on the insulating material to expose an electroactive surface of the working electrode and at least some edges of the sensor are stripped to expose sections of electroactive surface on the reference electrode. Other methods and configurations for exposing electroactive surfaces are also possible, for example by exposing the surfaces of the working electrode **26** between the coils of the reference electrode **28**. In some alternative embodiments, additional electrodes can be included within the assembly, for example, a three-electrode system (working, reference, and counter electrodes) and/or including an additional working electrode (which can be used to generate oxygen, configured as a baseline subtracting electrode, or configured for measuring additional analytes, for example).

[0114] A sensing membrane (not shown) is deposited over the electroactive surfaces of the sensor **10b** (working elec-

trode and optionally reference electrode) and includes a plurality of domains or layers, such as described above, with reference to FIG. 2A. The sensing membrane can be deposited on the exposed electroactive surfaces using known thin film techniques (for example, spraying, electro-depositing, dipping, or the like). In one exemplary embodiment, each domain is deposited by dipping the sensor into a solution and drawing out the sensor at a speed that provides the appropriate domain thickness. In general, the membrane system can be disposed over (deposited on) the electroactive surfaces using methods appreciated by one skilled in the art.

[0115] In the illustrated embodiment, the sensor glucose oxidase electrochemical sensor, wherein the working electrode **26** measures the hydrogen peroxide produced by an enzyme catalyzed reaction of the analyte being detected and creates a measurable electronic current (for example, detection of glucose utilizing glucose oxidase produces H_2O_2 peroxide as a by product, H_2O_2 reacts with the surface of the working electrode producing two protons ($2H^+$), two electrons ($2e^-$) and one molecule of oxygen (O_2) which produces the electronic current being detected), such as described in more detail above and as is appreciated by one skilled in the art.

[0116] FIG. 3 is a block diagram that illustrates the continuous glucose sensor electronics in one embodiment. In this embodiment, a potentiostat **30** is shown, which is operably connected to electrodes **24a** (FIG. 2) or **24b** (FIG. 3) to obtain a current value, and includes a resistor (not shown) that translates the current into voltage. An A/D converter **32** digitizes the analog signal into "counts" for processing. Accordingly, the resulting raw data stream in counts is directly related to the current measured by the potentiostat **30**.

[0117] A microprocessor **34** is the central control unit that houses EEPROM **36** and SRAM **38**, and controls the processing of the sensor electronics. Certain alternative embodiments can utilize a computer system other than a microprocessor to process data as described herein. In other alternative embodiments, an application-specific integrated circuit (ASIC) can be used for some or all the sensor's central processing. The EEPROM **36** provides semi-permanent storage of data, for example, storing data such as sensor identifier (ID) and programming to process data streams (for example, programming for data smoothing and/or replacement of signal artifacts such as described in copending U.S. patent application entitled, "SYSTEMS AND METHODS FOR REPLACING SIGNAL ARTIFACTS IN A GLUCOSE SENSOR DATA STREAM," filed Aug. 22, 2003). The SRAM **38** can be used for the system's cache memory, for example for temporarily storing recent sensor data. In some alternative embodiments, memory storage components comparable to EEPROM and SRAM can be used instead of or in addition to the preferred hardware, such as dynamic RAM, non-static RAM, rewritable ROMs, flash memory, or the like.

[0118] A battery **40** is operably connected to the microprocessor **34** and provides the necessary power for the sensor **10**. In one embodiment, the battery is a Lithium Manganese Dioxide battery, however any appropriately sized and powered battery can be used (for example, AAA, Nickel-cadmium, Zinc-carbon, Alkaline, Lithium, Nickel-metal hydride, Lithium-ion, Zinc-air, Zinc-mercury oxide, Silver-zinc, and/or hermetically-sealed). In some embodiments the battery is rechargeable. In some embodiments, a plurality of batteries can be used to power the system. A Quartz Crystal **42**

is operably connected to the microprocessor 34 and maintains system time for the computer system as a whole.

[0119] An RF Transceiver 44 is operably connected to the microprocessor 34 and transmits the sensor data from the sensor 10 to a receiver (see FIGS. 4 to 8) within a wireless transmission 46 via antenna 48. Although an RF transceiver is shown here, some other embodiments can include a wired rather than wireless connection to the receiver. In yet other embodiments, the receiver can be transcutaneously powered via an inductive coupling, for example. A second quartz crystal 50 provides the system time for synchronizing the data transmissions from the RF transceiver. The transceiver 44 can be substituted with a transmitter in other embodiments. In some alternative embodiments other mechanisms such as optical, infrared radiation (IR), ultrasonic, or the like can be used to transmit and/or receive data.

[0120] In one alternative embodiment, the continuous glucose sensor comprises a transcutaneous sensor such as described in U.S. Pat. No. 6,565,509 to Say et al. In another alternative embodiment, the continuous glucose sensor comprises a subcutaneous sensor such as described with reference to U.S. Pat. No. 6,579,690 to Bonnacaze et al. or U.S. Pat. No. 6,484,046 to Say et al. In another alternative embodiment, the continuous glucose sensor comprises a refillable subcutaneous sensor such as described with reference to U.S. Pat. No. 6,512,939 to Colvin et al. In another alternative embodiment, the continuous glucose sensor comprises an intravascular sensor such as described with reference to U.S. Pat. No. 6,477,395 to Schulman et al. In another alternative embodiment, the continuous glucose sensor comprises an intravascular sensor such as described with reference to U.S. Pat. No. 6,424,847 to Mastrototaro et al. All of the above patents are incorporated in their entirety herein by reference.

[0121] Although a few exemplary embodiments of continuous glucose sensors are illustrated and described herein, it should be understood that the disclosed embodiments are applicable to a variety of continuous glucose sensor configurations.

Integrated Receiver

[0122] The integrated receiver provides an integrated housing that includes a single point glucose monitor, electronics (for example, hardware and software) useful to receive and process data from the continuous glucose sensor and the single point glucose monitor, and a user interface that displays processed data to a user (for example, patient or doctor). FIGS. 4 to 7 illustrate preferred embodiments of the integrated receiver with a single point glucose monitor. FIGS. 8 to 10 illustrate some preferred electronics and data processing within the integrated receiver that are applicable to all embodiments of the integrated receiver (for example, FIGS. 4 to 7). Because the single point glucose monitor is integrated into the continuous sensor's receiver housing, there is no need for a separate glucose monitor to provide reference values for calibration or the like.

[0123] In the illustrated embodiments, the single point glucose monitor includes a meter for measuring glucose within a biological sample including a sensing region that has a sensing membrane impregnated with an enzyme, similar to the sensing membrane described with reference to FIG. 2, and such as described with reference to FIGS. 4 to 7. However, in alternative embodiments, the single point glucose monitor can use other measurement techniques such as optical, for example.

[0124] FIG. 4A is a perspective view of an integrated receiver in one embodiment showing a single point glucose monitor in its closed position. FIG. 4B is an exploded perspective view of the integrated receiver, showing the single point glucose monitor with the cover removed to reveal the receptacle inside. The integrated receiver 12 provides a housing that integrates a single point glucose monitor 14 and electronics (FIG. 8) useful to receive, process and display data on the user interface 16. The single point glucose monitor permits rapid and accurate measurement of the amount of a particular substance (for example, glucose) in a biological fluid.

[0125] The integrated receiver 12 includes a main housing 62 and a cartridge 64 that is removably mounted on the housing 62, which permits the cartridge 64 to be disposable and replaceable as needed. The housing 62 includes a case 66 having an upper portion 68 and a lower portion 70. The upper portion 68 and lower portion 70 are connected together by any particular fastening means such as several screws (not shown).

[0126] The main housing 62 also includes electronic circuitry operably connected to at least two electrodes (not shown). The electrodes are preferably mounted within a sensing region 72 that supports the electrodes as they extend upwardly therein. A sensing membrane (not shown) overlays the electrodes on the sensing region 72 and is operably associated with the electrodes when the cartridge is removably mounted on the housing. The cartridge 64 also includes means for protecting the sensing membrane when not in use. The protection means is preferably a cover 74 that is movably mounted on a body portion 76 of the cartridge 64. Alternatively, the cover 74 can be mounted on the case 66. In the illustrated embodiment, a hinge assembly 78 movably mounts the cover 74 on the body portion 76.

[0127] Generally, the cover 74 has a first position such as shown in FIG. 4A in which it protects the membrane, and a second position. Access to the sensing membrane is preferable in order to conveniently place the biological fluid sample on the sensing membrane for analysis.

[0128] The housing 62 preferably defines a well 80 having a bottom 82. In practice, the biological fluid sample is placed on the sensing region 72 in the well 80 for analysis. Generally, the well 80 defines an opening of less than 4 millimeters in diameter and less than 2 millimeters in depth. As a result, the well has a volume of less than about 0.1 to 0.2 cubic centimeters. These dimensions substantially minimize the size of the biological fluid sample necessary for analysis down to the sample sizes as small as about five microliters. Because the size of the sample can be particularly small, compensation for temperature changes during analysis that was often necessary with previous devices can be avoided.

[0129] The protection means of the cartridge 64 preferably also includes means for sealing the well 80 and hence the sensing region including the sensing membrane, which is disposed at the bottom of the well 80, from the ambient surroundings.

[0130] A retaining means is also provided for releasably retaining the cartridge 64 and its body portion 76 on the housing 62. The retaining means preferably includes a detent 84 on the cartridge 64, which is received in a recess defined by the upper portion 68 of the case 66. The retaining means also preferably includes at least one, preferably two wings 86 on the body portion 76 of the cartridge 64 which are received in one or more slots 88 on the case 66. The slots 88 are generally

perpendicular to the cover **74** so that opening the cover will not disengage the wings **86** from the slots **88**.

[0131] The sensing region **72**, in which the electrodes are disposed, is preferably generally annular in design with the interior portion thereof filled with an electrically nonconductive support material such as a hardened polyepoxide-containing resin. The electrically nonconductive support material and the top (electrochemically reactive) surfaces of the electrodes define a sensing membrane contact surface. Namely, the sensing membrane can be stretched over the contact surface to more effectively place the membrane in operative association with the electrodes (not shown). In an alternative embodiment of the sensing region **72**, the electrodes can be deposited onto a ceramic surface, and an electrically nonconductive material can be applied as a coating over the electrodes to form an insulating barrier. A portion of each electrode, however, is not coated to form a membrane contact surface so that a membrane can be applied over the electrodes in operative contact therewith.

[0132] Generally, the sensing membrane can be constructed substantially similar to the sensing membrane described with reference to FIG. **2**. For example, the sensing membrane includes a resistance domain most distal from the electrochemically reactive surfaces, an enzyme domain less distal from the electrochemically reactive surfaces than the resistance domain, an interference domain less distal from the electrochemically reactive surfaces than the enzyme domain, and an electrolyte domain adjacent to the electrochemically reactive surfaces. However, it is understood that the sensing membrane can be modified for other devices, for example, by including fewer or additional domains. Furthermore, design considerations for the sensing membrane of the single point glucose monitor can differ from that of the continuous glucose sensor due to oxygen availability, for example.

[0133] In some embodiments, the domains of the sensing membrane are formed from materials such as silicone, polytetrafluoroethylene, polyethylene-co-tetrafluoroethylene, polyolefin, polyester, polycarbonate, biostable polytetrafluoroethylene, homopolymers, copolymers, terpolymers of polyurethanes, polypropylene (PP), polyvinylchloride (PVC), polyvinylidene fluoride (PVDF), polybutylene terephthalate (PBT), polymethylmethacrylate (PMMA), polyether ether ketone (PEEK), polyurethanes, cellulosic polymers, polysulfones and block copolymers thereof including, for example, di-block, tri-block, alternating, random and graft copolymers.

[0134] The cover **74** is preferably provided with a closure means (not shown) such as one or more latches that engage the body portion **76**. Generally, the force necessary to disengage the closure means from the body portion should be less than that necessary to disengage the wings **86** from the slots **88**. In this manner, an operator can easily open the cover **74** without accidentally disengaging the cartridge **64** from the main housing **62**.

[0135] The sensing region **72**, including the electrodes and sensing membrane, contacts the body fluid sample for analysis. The sensing region **72** is operably associated with the electronic circuitry (see FIG. **8**) that analyzes the current from the reaction of the components in the body fluid with the electrodes. The electronic circuitry is in turn operably associated with the user interface **16** (for example, such as a liquid crystal display) to indicate glucose concentration.

[0136] In one embodiment, the electrode configuration includes a three-electrode electrochemical cell, which in

combination with the chemical reactions occurring in the sensing membrane and on the electrochemically reactive surfaces, makes possible consistent electrode behavior and, in particular, performance of a reference electrode that is stable with time. However, in alternative embodiments, wherein the electrode configuration includes a two-electrode electrochemical cell with a reference cathodic, chloride ions will be lost from the reference electrode that eventually leads to unstable electrode behavior. According to the preferred embodiments, permanent stable reference electrode behavior is achieved when the hydrogen peroxide produced in the membrane oxidizes the silver metal to silver oxide which is then converted to silver chloride by chloride ion. Advantages include ease of manufacturing of the electrode, self-forming and self-maintaining electrode behavior, and long-term reference electrode stability.

[0137] In general, the glucose measurement technique of the integrated receiver **12** is similar to that described with reference to FIGS. **2** and **3**, above, however the electronics are adapted for single point measurement. The electronics associated with the integrated receiver **12** are described in more detail below with reference to FIG. **8**. Generally, glucose from a biological sample produces a current flow at a working electrode, with equal current provided by a counter electrode in a reference circuit. The current is converted in an analog section by a current to voltage converter to a voltage, which is inverted, level-shifted, and delivered to an A/D converter in the microprocessor (see FIG. **8**). As part of the calibration, the microprocessor can set the analog gain via its control port. The A/D converter is preferably activated at one-second intervals. The microprocessor looks at the converter output with any number of pattern recognition algorithms known to those skilled in the art until a glucose peak is identified. A timer is then activated for about 30 seconds at the end of which time the difference between the first and last electrode current values is calculated. This difference is then divided by the value stored in the memory during instrument calibration and is then multiplied by the calibration glucose concentration. The result includes a calibrated glucose concentration value that is meaningful to a user, and useful in calibrating the data stream from the continuous glucose sensor **10**, for example.

[0138] The single point glucose monitor described with reference to FIGS. **4A** and **4B** can be calibrated by the user as described in more detail with reference to U.S. Pat. Nos. 4,994,167 and 4,757,022, both of which are incorporated herein in their entirety. The ability to calibrate the glucose monitor is particularly advantageous, for example, as compared to a conventional test strip, which cannot be calibrated by the user.

[0139] Additionally, the similarity of the sensing membranes used for the continuous glucose sensor and the single point glucose sensor provides an internal control that creates increased reliability by nature of consistency and decreased error potential that can otherwise be increased due to combining dissimilar measurement techniques. Additionally, the disclosed membrane system is known to provide longevity, repeatability, and cost effectiveness, for example as compared to single use strips, or the like.

[0140] During the data processing, prompts or messages can be displayed on the user interface **16** to guide the user through the calibration and sample measurement procedures. In addition, prompts can be displayed to inform the user about necessary maintenance procedures, such as "Replace Sensor"

or "Replace Battery." An on/off button **90** preferably initiates the operation and calibration sequences.

[0141] Methods and devices that can be suitable for use in conjunction with aspects of the above-described preferred embodiments are disclosed in copending applications including U.S. Pat. No. 4,994,167 and U.S. Pat. No. 4,757,022. The integrated receiver electronics and its integration with the continuous glucose sensor are described in more detail below with reference to FIGS. **8** to **10**.

[0142] FIGS. **5A** to **5E** illustrate another embodiment of an integrated receiver, wherein the single point glucose monitor includes a stylus movably mounted to the integrated receiver for measurement of glucose in a biological sample. FIG. **5A** is a perspective view of the integrated receiver housing in another embodiment, showing a single point glucose monitor including a stylus movably mounted to the integrated receiver, wherein the stylus is shown in a storage position. FIG. **5B** is a perspective view of the integrated housing of FIG. **5A**, showing the stylus in a testing position. FIG. **5C** is a perspective view of a portion of the stylus of FIG. **5A**, showing the sensing region. FIG. **5D** is a perspective view of the integrated receiver housing of FIG. **5A**, showing the stylus loaded with a disposable film, and in its testing position. FIG. **5E** is a perspective view of a portion of the stylus of FIG. **5A**, showing the sensing region with a disposable film stretched and/or disposed thereon.

[0143] In this embodiment, the integrated receiver provides **92** a housing that integrates a single point glucose monitor **94** and electronics (see FIG. **8**) useful to receive, process, and display data on the user interface **96**. The single point glucose monitor **94** permits rapid and accurate measurement of the amount of a particular substance (for example, glucose) in a biological fluid. Generally, the integrated receiver electronics process single point glucose monitor data, receive and process continuous glucose sensor data, including calibration of the continuous sensor data using the single point monitor data for example, and output data via the user interface **96**, such as is described below in more detail with reference to FIG. **8**.

[0144] The single point glucose monitor **94** includes a stylus **98** that is movably mounted to the integrated receiver housing **92** via a connector **93**. The connector **93** can be a cord, bar, hinge, or any such connection means that allows the stylus to move from a first (storage) position (FIG. **5A**) to a second (testing) position (FIG. **5B**) on the housing. The stylus is not constrained to the first and second positions; rather the stylus can be configured to swing at various angles, about various pivots, or in any manner allowed by the connector for convenience to the user. In some alternative embodiments, the stylus **98** is removably mounted on the integrated receiver housing **92** and an operable connection can be established using a wireless connection, or alternatively using electrical contacts that operably connect the stylus **98** that is removably mounted onto the integrated receiver housing **92**.

[0145] The stylus **98** includes a sensing region **100** on one end that is operably connected to the integrated receiver's electronics (FIG. **8**). As best illustrated in FIG. **5C**, the sensing region **100** is provided with at least two, preferably three electrodes **102** and a sensing membrane (not shown) disposed over the electrodes **102** and/or the entire sensing region **100**. The sensing region includes the electrodes **102** and the sensing membrane, which are configured to measure glucose in a manner such as described above with reference to the sensing region of FIGS. **2** and **4**. In one embodiment, the sensing membrane is reusable and can be held on the sensing region

100 by a clip, such as described with reference to FIG. **2**. In alternative embodiments, the sensing membrane is reusable and can be disposed onto the sensing region using depositing or bonding techniques known in the art of polymers.

[0146] In order to maintain a preferred wetness of the sensing region **100**, and particularly of the sensing membrane, the integrated receiver housing **92** includes a sterile solution chamber (not shown) located at the end of the receiving chamber **104** that receives the stylus for storage, such that when the stylus is in its storage position (FIG. **5A**), the sensing membrane is maintained in the sterile solution. A sterile solution port **106** is in communication with the sterile solution chamber and allows for refilling of the sterile solution chamber using a sterile refill solution **108**.

[0147] Typically, when a biological sample **106** (FIG. **5E**) is placed on a surface, such as the surface of the sensing membrane and/or sensing region **100**, there is a concern about contamination of the surface after use of the biological sample **106**. Therefore, a single-use disposable bioprotective film **109** can be placed over the sensing region **100** to provide protection from contamination. The disposable film **109** can be any film with that allows the passage of glucose, but blocks the passage of undesired species in the blood that could damage or contaminate the sensing membrane and/or cause inaccurate measurements (for example, a thin film of very low molecular weight cutoff to prevent the transport of proteins, viruses, etc).

[0148] In some alternative embodiments, the bioprotective film **109** further comprises a sensing membrane formed as a part of the film (for example, laminated to the film), instead of (or in addition to) a sensing membrane disposed on the sensing region. This alternative embodiment is particularly advantageous in that it provides a disposable sensing membrane that requires no cleaning step, for example.

[0149] Because the stylus **98** can be put into direct contact with the biological sample **106** (for example, on a finger or arm), no transfer mechanism is required, and therefore the sample size can be smaller than conventionally required. Additionally, sensing region **100** does not require a separate cleaning step, because the disposable film **109** fully protects the sensing region **100** from contamination, and should be disposed of after use.

[0150] The integrated receiver **92** housing further allows for storage and dispensing of the disposable films **109**. A shuttle mechanism **110** is provided that preferably feeds the films **109** into a spring-loaded storage chamber (not shown) beneath the shuttle mechanism **110**, or the like. The shuttle mechanism **110** can be used to load the disposable films **109**, one at a time, into a dispensing chamber **111** for dispensing onto the sensing region. In alternative embodiments, other storage and dispensing mechanisms can be configured as a part of the integrated receiver housing **12** or separate therefrom.

[0151] In practice, the stylus **98** is held in its storage position within the receiving chamber **104** where it is protected and maintained with a preferred wetness (FIG. **5A**). A user then withdraws the stylus **98** from the receiving chamber **104** (FIG. **5B**) and loads a disposable film **109** by sliding the shuttle mechanism **110** toward the dispensing chamber **111**. When the sensing region **100** of the stylus **98** presses on the disposable film **109** within the dispensing chamber, the film will be stretched over and/or otherwise stick to the moist sensing membrane on the surface of the sensing region **100** (FIG. **5D**). At this point, the stylus **98** is ready for a biological

sample (for example, blood sample) **106**. The stylus **98** can be brought into contact with the finger or arm of the user to directly receive the biological sample from the user without the need for a transfer mechanism (FIG. 5E). After the test, the disposable film is removed from the sensing region and the stylus **98** is replaced into the receiving chamber **104** of the integrated receiver **92**.

[0152] In this embodiment, the sensing region measures the glucose concentration of the biological sample in a manner such as described with reference to FIGS. 2 and 4, above. The integrated receiver's electronics, including data processing and calibration, are described in more detail below with reference to FIG. 8.

[0153] FIGS. 6A to 6J illustrate yet another embodiment of an integrated receiver, including a single point glucose monitor, electronics, and a disposable filtering capillary tube. FIG. 6A is a perspective view of the integrated receiver in yet another embodiment, including a single point glucose monitor and a disposable capillary tube for transferring a biological sample to a sensing region on the monitor. FIG. 6B is a perspective view of the integrated receiver of FIG. 6A, showing the disposable capillary tube inserted into the single point glucose monitor to transfer the biological sample to a sensing region on the single point glucose monitor. FIG. 6C is an expanded perspective view of a portion of the integrated receiver of FIG. 6A, showing the capillary tube inserted into the single point glucose monitor. FIG. 6D is a schematic cross-sectional view of a portion of the integrated receiver of FIG. 6A, illustrating the capillary tube in contact with a sensing membrane such that glucose from the biological sample can be measured by electrodes on the sensing region. FIG. 6E is a schematic cross-sectional view of the capillary tube of FIG. 6A, illustrating an embodiment wherein a filter is located on one end. FIG. 6F is a schematic cross-sectional view of the capillary tube of FIG. 6A, illustrating an embodiment wherein a filter is disposed between two ends. FIG. 6G is a schematic cross-sectional view of the capillary tube of FIG. 6A, illustrating an embodiment wherein a vent extends from the capillary tube. FIG. 6H is a schematic illustration of one embodiment, wherein the capillary tube **132** is round in shape with an inner capillary tube that is also round in shape. FIG. 6I is a schematic illustration of one embodiment, wherein the capillary tube **132** is rectangular in shape with an inner capillary tube **144** that is formed therein. FIG. 6J is a schematic illustration of one embodiment, wherein the capillary tube **132** is rectangular in shape and an inner capillary tube **144** has a rounded structure.

[0154] In this embodiment, the integrated receiver provides a housing **112** that integrates a single point glucose monitor **114** and electronics (see FIG. 8) useful to receive, process, and display data on a user interface **116**. The single point glucose monitor **114** permits rapid and accurate measurement of the amount of a particular substance (for example, glucose) in a biological sample. Generally, the electronics that process single point glucose monitor data, receive and process continuous glucose sensor data, including calibration of the continuous sensor data using the single point monitor data for example, and output data via the user interface **116**, are described below in more detail with reference to FIG. 8. Buttons **118** can be provided on this or any of the preferred integrated receiver embodiments in order to facilitate user interaction with the integrated receiver.

[0155] The single point glucose monitor **114** includes a sensor port **120** configured to receive a biological fluid and

measure its glucose concentration therefrom. As best illustrated in FIG. 6D, a sensing region **122**, which includes a sensing membrane **124** (such as described in more detail elsewhere herein), is located within the sensor port **120**. The sensing region includes electrodes **126**, the top ends of which are in contact with an electrolyte phase (not shown), which is a free-flowing fluid phase disposed between the sensing membrane **124** and the electrodes **126**. The sensing region **122** measures glucose in the biological sample in a manner such as described in more detail above, with reference to the sensing regions of FIGS. 2, 4, and 5. In some embodiments, the sensor port **120** includes a cover (not shown) configured to cover the sensing membrane **124** when the single glucose monitor is not in use in order to maintain a preferred wetness of the sensing region **122**, and particularly of the sensing membrane.

[0156] Typically, when a biological sample is placed in on a surface (e.g., the sensing membrane **124**), there is a concern about contamination of the surface from the biological sample. Therefore, a single-use disposable capillary tube **132** can be provided to transport and filter the biological sample, for example from a blood sample of a finger or arm, to the sensing region **122**. The disposable capillary tube **132** uses capillary action to draw the biological sample from a first end **134** to a second end **136** of the capillary tube **132**. A filter **140** is provided within the capillary tube **132**, which is designed to allow the passage of glucose, but filter or block the passage of undesired species in the biological sample that could damage or contaminate the sensing membrane and/or cause inaccurate measurements (for example, the filter can be formed from a membrane of very low molecular weight cutoff to prevent the transport of proteins, viruses, etc). Because the filter **140** protects the sensing region **122** from contamination, the sensing region does not require a separate cleaning step, and the filter should be disposed of after use.

[0157] Referring now to FIGS. 6E to 6G, various embodiments of the filter within the capillary tube are illustrated. Each capillary tube **132** has a capillary inlet **142** at a first end **134**, an inner capillary tube **144**, a filter **140**, and an outlet **146** on the second end **136**. The capillary tube **132** enables the transport of blood or other aqueous solutions from the capillary inlet **142** to the capillary outlet **146**. The fluid transport is facilitated by capillary action and preferably enabled by a hydrophilic surface of the inner capillary tube **144**. In some embodiments, some portions of the inner capillary tube **144** can be made hydrophobic to control fluid flow. In some embodiments, the inner capillary tube **144** has a volume between about 2 and 3 microliters; however a larger or smaller volume is possible.

[0158] FIG. 6E is a schematic cross-sectional view of the capillary tube in one embodiment, wherein a filter **140** is disposed at the second end **136** within the inner capillary tube **144**. This embodiment of the capillary tube is designed to filter the biological sample prior to its exit out of the capillary tube outlet **146**.

[0159] FIG. 6F is a schematic cross-sectional view of the capillary tube in another embodiment, wherein the filter **140** is within the wall of the capillary tube **132** rather than within the inner capillary tube **144**. In this embodiment, the open inner capillary tube is designed to ensure accurate and repeatable fluid flow through the capillary tube by allowing displaced air to escape from the capillary tube outlet **146**. As the fluid passes through the inner capillary tube **144**, at least a portion of the bodily fluid flows down through the filter **140** and exits the

capillary tube **132** through a side exit **141**. In some embodiments, the surface of the inner capillary tube **144** near the second end of the capillary can be altered to be hydrophobic thereby preventing blood from escaping the second end.

[0160] FIG. 6G is a schematic cross-sectional view of the capillary tube in yet another embodiment, wherein the capillary tube further comprises a vent **148**. This embodiment of the capillary tube is designed to ensure accurate and repeatable fluid flow through the capillary tube, by allowing displaced air and other gases to escape from the vent **148**, which is located on a side of the capillary tube at a position that allows air to escape prior to filtering of the biological fluid through the filter **140**.

[0161] Referring now to FIGS. 6H to 6J, various embodiments of the capillary tube structure are illustrated. The schematic views are intended to be exemplary and do not represent scale or proportion of the capillary tubes.

[0162] FIG. 6H is a schematic illustration of one embodiment, wherein the capillary tube **132** is round in shape with an inner capillary tube that is also round in shape. This is an embodiment similar to that shown in FIG. 6A to 6D, and optionally includes a tab, wings, or other structure to aid in handling and/or mechanical alignment of the tube **132**.

[0163] FIG. 6I is a schematic illustration of one embodiment, wherein the capillary tube **132** is rectangular in shape with an inner capillary tube **144** that is formed therein. In one embodiment, the inner capillary tube **144** can be formed by methods, for example as known in the art of manufacturing test strips used for self-monitoring blood glucose meters.

[0164] FIG. 6J is a schematic illustration of one embodiment; wherein the capillary tube **132** is rectangular in shape an inner capillary tube **144** has a rounded structure. Shape, dimensions, proportions, or the like do not limit the capillary tube of the preferred embodiments, provided that the capillary tube is capable of performing capillary action.

[0165] The capillary tubes **132** can be manufactured using materials such as plastic, glass, silicon, or the like. In one embodiment, the preferred manufacturing material is plastic because of its low cost and the availability of numerous manufacturing processes. The inner capillary tube **144** can be molded or embossed to form the capillary structure. In some alternative embodiments, such as shown FIG. 6I, the inner capillary tube **144** can be formed by multi-layers including a top-capping layer that forms the capillary structure. Adhesive, ultrasonic bonding, solvents or other methods can be used to bond the layers. Holding tabs are not employed in certain embodiments of the capillary tube depending on their structure, for example the capillary tubes shown in FIGS. 6H to 6J.

[0166] In some embodiments, it can be advantageous to place a means of detecting a proper fill of the capillary. This can be accomplished for example by electrical means, optical means, or the like. In some embodiments (not shown), the integrated receiver housing **112** can be designed with a means for storing and dispensing capillary tubes **132**. In alternative embodiments, other storage and/or dispensing means can be configured separate from the integrated receiver housing **112**.

[0167] In practice, a user obtains a biological sample from a source, such as a finger or forearm (in some alternative embodiments, the single point glucose monitor can be designed to measure biological fluids other than blood, such as urine, sweat, or the like). The user then grasps a disposable capillary tube **132** (e.g., tab or outer surface) and contacts the source with the capillary inlet **142**. Because of the design of

the inner capillary tube **144**, capillary action causes the biological sample to be drawn towards the capillary outlet **146**. The biological sample is filtered as it passes through the filter **140**, which is permeable to glucose but impermeable to large molecules and species in the blood that can clog, damage, or contaminate the sensing membrane **124**, and/or cause inaccurate measurements. Therefore, the biological sample permeates the filter **140** and into the sensing membrane **124** (for example, fluid contact between the capillary tube and sensing membrane enables the transfer of the filtered biological sample), where it enzymatically reacts with the catalyst (e.g., glucose oxidase) and produces hydrogen peroxide. Hydrogen peroxide is detected by the electrochemical sensor, wherein the electrical signal is converted into glucose value, such as described in more detail elsewhere herein.

[0168] The sensing membrane **124** is a reusable component of the single point glucose monitor, which advantageously provides a low cost associated with each glucose measurement as compared to conventional glucose measuring test strips. Additionally, the disposable capillary tube **132** simplifies the cleanup of the device, as compared to conventional single point glucose monitors that utilize similar enzyme membrane technology. Furthermore, because the blood remains within the capillary tube **144**, which can be disposed of without contaminating the integrated receiver housing **112** or the sensing membrane **124**, the risk of human contact with blood is reduced.

[0169] FIGS. 7A and 7B are perspective views of yet another embodiment of an integrated receiver, wherein the single point glucose monitor is detachably connected to the receiver housing to provide a modular configuration. FIG. 7A is a perspective view of the integrated receiver in this embodiment, wherein the single point glucose monitor is detachably connected to the receiver to form a modular configuration, shown in its connected state. FIG. 7B is a perspective view of the integrated receiver of FIG. 7A, shown in its detached state.

[0170] In this embodiment, the integrated receiver **150** provides a receiver housing **152** and a single point glucose monitor **154**, which are detachably connectable to each other. The receiver housing **152** includes electronics (hardware and software) useful to receive, process, and display data from the continuous glucose sensor and/or the single point glucose sensor on a user interface **156**, such as described in more detail with reference to FIG. 8. In some embodiments, some part of the electronics (for example, the electronics specific to the single point glucose monitor **154**) can be housed within the single point glucose monitor **154**. The single point glucose monitor **154** can be configured as described with reference to FIG. 6, for example, to permit rapid and accurate measurements of the amount of a particular substance (for example, glucose) in a biological sample. In alternative embodiments, the single point glucose monitor of this modular embodiment can be configured as described with reference to any of the single point glucose monitors of the preferred embodiments. In yet alternative embodiments, the single point glucose monitor can be configured using other known glucose meter configurations.

[0171] In general, this embodiment provides for a modular configuration between a receiver housing **152** and a single point glucose monitor **154**, wherein the single point glucose monitor can be detached when a user prefers to carry a smaller, simpler, or lighter device (for example, during exercise). However, when a user is ready to perform a single point glucose test, the glucose monitor **154** can be easily attached to

the receiver **152** to form an integrated receiver **150** with its numerous associated advantages. In one embodiment, electrical contacts (not shown) on the receiver housing **152** and the single point glucose monitor **154** allow an electrical connection to be established in its attached position. In another embodiment, a wireless connection between the receiver housing **152** and the single point glucose monitor **154** can be provided, wherein the integration is advantageous for its convenient one-piece system (for example, fewer loose parts), its similar measurement technologies (for example, enzyme membrane-based electrochemical measurement), and its added versatility to function even when the modular device is detached.

[0172] While not required, it is preferred in this embodiment that the single point glucose monitor **154** be dependent upon the integrated receiver **152** for at least a portion of its operation. For example, at least some of the electronics and/or user interface for the single point glucose monitor **154** are located within the receiver **152**. Numerous advantages associated with the integrated receiver **150**, such as ensuring accurate time stamping of the single point glucose test at the receiver and other advantages described herein, can be provided by an integrated continuous glucose receiver and single point glucose monitor, such as described herein.

[0173] Additionally, the integrated receiver housing configurations of the preferred embodiments are advantageous in that they can be calibrated by the user and can be designed with a measurement technique consistent with that of the continuous glucose sensor. These and other advantages can be seen in alternative embodiments of the device of the preferred embodiments, which are described in more detail elsewhere herein.

[0174] In one alternative embodiment, the single point glucose monitor comprises an integrated lancing and measurement device such as described in U.S. Pat. No. 6,607,658 to Heller et al. In another alternative embodiment, the single point glucose monitor comprises a near infrared device such as described in U.S. Pat. No. 5,068,536 to Rosenthal et al. In another alternative embodiment, the single point glucose monitor comprises an integrated lancer, blood-monitoring device, and medication delivery pen, such as described in U.S. Pat. No. 6,192,891 to Gravel et al. In another alternative embodiment, the single point glucose monitor comprises a reflectance reading apparatus such as described in U.S. Pat. No. 5,426,032 to Phillips et al. In another alternative embodiment, the single point glucose monitor comprises a spectroscopic transmittance device such as described in U.S. Pat. No. 6,309,884 to Cooper et al. Other integrations that can be combined with the integrated receiver are described in co-pending U.S. patent application Ser. No. 10/789,359, filed Feb. 26, 2004. All of the above patents and patent applications are incorporated in their entirety herein by reference.

[0175] FIG. **8** is a block diagram that illustrates integrated receiver electronics in one embodiment. The described electronics are applicable to the preferred embodiments, including the integrated receiver **12** of FIGS. **1**, **4A**, and **4B**, the integrated receiver **92** of FIGS. **5A** to **5E**, the integrated receiver **112** of FIGS. **6A** to **6D**, and the integrated receiver **150** of FIGS. **7A** and **7B**.

[0176] A quartz crystal **160** is operably connected to an RF transceiver **162**, which together function to receive and synchronize data streams **164** via an antenna **166** (for example,

transmission **46** from the RF transceiver **44** shown in FIG. **3**). Once received, a microprocessor **168** processes the signals, such as described below.

[0177] The microprocessor **168** is the central control unit that provides the processing, such as storing data, analyzing continuous glucose sensor data stream, analyzing single point glucose values, accuracy checking, checking clinical acceptability, calibrating sensor data, downloading data, and controlling the user interface by providing prompts, messages, warnings and alarms, or the like. The EEPROM **170** is operably connected to the microprocessor **168** and provides semi-permanent storage of data, storing data such as receiver ID and programming to process data streams (for example, programming for performing calibration and other algorithms described elsewhere herein). SRAM **172** is used for the system's cache memory and is helpful in data processing. For example, the SRAM stores information from the continuous glucose sensor and the single point glucose monitor for later recall by the user or a doctor; a user or doctor can transcribe the stored information at a later time to determine compliance with the medical regimen or a comparison of glucose concentration to medication administration (for example, this can be accomplished by downloading the information through the PC communication port **174**). In addition, the SRAM **172** can also store updated program instructions and/or patient specific information. FIGS. **9** and **10** describe more detail about programming that is preferably processed by the microprocessor **168**. In some alternative embodiments, memory storage components comparable to EEPROM and SRAM can be used instead of or in addition to the preferred hardware, such as dynamic RAM, non-static RAM, rewritable ROMs, flash memory, or the like.

[0178] A battery **176** is operably connected to the microprocessor **168** and provides power for the receiver. In one embodiment, the battery is a standard AAA alkaline battery, however any appropriately sized and powered battery can be used. In some embodiments, a plurality of batteries can be used to power the system. In some embodiments, a power port (not shown) is provided permit recharging of rechargeable batteries. A quartz crystal **178** is operably connected to the microprocessor **168** and maintains system time for the computer system as a whole.

[0179] A PC communication (com) port **174** can be provided to enable communication with systems, for example, a serial communications port, allows for communicating with another computer system (for example, PC, PDA, server, or the like). In one exemplary embodiment, the receiver is able to download historical data to a physician's PC for retrospective analysis by the physician. The PC communication port **174** can also be used to interface with other medical devices, for example pacemakers, implanted analyte sensor patches, infusion devices, telemetry devices, or the like.

[0180] Electronics associated with the single point glucose monitor **180** are operably connected to the microprocessor **168** and include a potentiostat **181** in one embodiment that measures a current flow produced at the working electrode when a biological sample is placed on the sensing membrane, such as described with reference to FIGS. **4** to **7**, for example. The current is then converted into an analog signal by a current to voltage converter, which can be inverted, level-shifted, and sent to the A/D converter **182**. The microprocessor can set the analog gain via its control port (not shown). The A/D converter is preferably activated at one-second intervals. The microprocessor looks at the converter output with any number of pattern recognition algorithms known to those

skilled in the art until a glucose peak is identified. A timer is then preferably activated for about 30 seconds at the end of which time the difference between the first and last electrode current values is calculated. This difference is then divided by the value stored in the memory during instrument calibration and is then multiplied by the calibration glucose concentration. The glucose value in milligram per deciliter, millimoles per liter, or the like, is then stored in the microprocessor, displayed on the user interface, used to calibrate of the glucose sensor data stream, downloaded, etc.

[0181] A user interface **184** comprises a keyboard **186**, speaker **188**, vibrator **190**, backlight **192**, liquid crystal display (LCD) **194**, and one or more buttons **196**. The components that comprise the user interface **184** provide controls to interact with the user. The keyboard **186** can allow, for example, input of user information about an individual, such as mealtime, exercise, insulin administration, and reference glucose values. The speaker **188** can provide, for example, audible signals or alerts for conditions such as present and/or predicted hyper- and hypoglycemic conditions. The vibrator **190** can provide, for example, tactile signals or alerts for reasons such as described with reference to the speaker, above. The backlight **192** can be provided, for example, to aid the user in reading the LCD in low light conditions. The LCD **194** can be provided, for example, to provide the user with visual data output. In some embodiments, the LCD is a touch-activated screen. The buttons **196** can provide for toggle, menu selection, option selection, mode selection, and reset, for example. In some alternative embodiments, a microphone can be provided to allow for voice-activated control.

[0182] The user interface **184**, which is operably connected to the microprocessor **168** serves to provide data input and output for both the continuous glucose sensor (for example, FIGS. **2** and **3**) and for the integrated receiver including the single point glucose monitor (for example, FIGS. **4** to **7**).

[0183] In some embodiments, prompts or messages can be displayed on the user interface to guide the user through the initial calibration and sample measurement procedures for the single point glucose monitor. Additionally, prompts can be displayed to inform the user about necessary maintenance procedures, such as "Replace Sensing Membrane" or "Replace Battery." Even more, the glucose concentration value measured from the single point glucose monitor can be individually displayed.

[0184] In some embodiments, prompts or messages can be displayed on the user interface to convey information to the user, such as malfunction, outlier values, missed data transmissions, or the like, for the continuous glucose sensor. Additionally, prompts can be displayed to guide the user through calibration of the continuous glucose sensor. Even more, calibrated sensor glucose data, which is described in more detail with reference to FIGS. **9** and **10**, can be displayed in numerical or graphical representations, or the like.

[0185] Reference is now made to FIG. **9**, which is a flow chart that illustrates the process of initial calibration and data output of the glucose sensor **10** in one embodiment. Calibration of the glucose sensor **10** generally includes data processing that converts a sensor data stream into estimated glucose values that are meaningful to a user. Accordingly, a reference glucose value can be used to calibrate the data stream from the glucose sensor **10**. The calibration can be performed on a real-time basis and/or backwards recalibrated (for example, retrospectively).

[0186] At block **200**, a sensor data receiving module, also referred to as the sensor data module, receives sensor data (for example, a data stream), including one or more time-spaced sensor data points, hereinafter referred to as "sensor data" or "sensor glucose data." The integrated receiver receives the sensor data from a continuous glucose sensor, which can be in wired or wireless communication with the integrated receiver. Some or all of the sensor data point(s) can be smoothed or replaced by estimated signal values such as described with reference to co-pending U.S. patent application entitled, "SYSTEMS AND METHODS FOR REPLACING SIGNAL ARTIFACTS IN A GLUCOSE SENSOR DATA STREAM," filed Aug. 22, 2003. During the initialization of the sensor, prior to initial calibration, the integrated receiver (for example, FIGS. **4** to **7**) receives and stores the sensor data, however it does not necessarily display any data to the user until initial calibration and optionally stabilization of the sensor **10** has been determined.

[0187] At block **202** a single point glucose module, also referred to as the reference input module, receives glucose data from the integrated single point glucose monitor, including one or more reference glucose data points, hereinafter referred to as "reference data" or "reference glucose data." Namely, the single point glucose monitor, such as described in more detail with reference to FIGS. **4** to **7**, which is integral with the receiver, provides a reference glucose concentration value, such as described above with respect to the single point glucose monitors of the preferred embodiments. The reference glucose concentration value from the single point glucose monitor is calibrated such as described above in more detail with reference to FIG. **8**.

[0188] In some embodiments, the microprocessor **168** monitors the continuous glucose sensor data stream to determine a preferable time for capturing glucose concentration values using the single point glucose monitor electronics **180** for calibration of the continuous sensor data stream. For example, when sensor glucose data (for example, observed from the data stream) changes too rapidly, a single point glucose monitor reading may not be sufficiently reliable for calibration during unstable glucose changes in the host; in contrast, when sensor glucose data are relatively stable (for example, relatively low rate of change), a single point glucose monitor reading can be taken for a reliable calibration. In some additional embodiments, the microprocessor can prompt the user via the user interface to obtain a single point glucose value for calibration at predetermined intervals. In some additional embodiments, the user interface can prompt the user to obtain a single point glucose monitor value for calibration based upon certain events, such as meals, exercise, large excursions in glucose levels, faulty or interrupted data readings, or the like. In some embodiments, certain acceptability parameters can be set for reference values received from the single point glucose monitor. For example, in one embodiment, the receiver only accepts reference glucose data between about 40 and about 400 mg/dL.

[0189] At block **204**, a data matching module, matches reference data (for example, one or more reference glucose data points) with substantially time corresponding sensor data (for example, one or more sensor data points) to provide one or more matched data pairs. In one embodiment, one reference data point is matched to one time corresponding sensor data point to form a matched data pair. In another embodiment, a plurality of reference data points are averaged (for example, equally or non-equally weighted average,

mean-value, median, or the like) and matched to one time corresponding sensor data point to form a matched data pair. In another embodiment, one reference data point is matched to a plurality of time corresponding sensor data points averaged to form a matched data pair. In yet another embodiment, a plurality of reference data points are averaged and matched to a plurality of time corresponding sensor data points averaged to form a matched data pair.

[0190] In one embodiment, time corresponding sensor data comprises one or more sensor data points that occur, for example, 15±5 min after the reference glucose data timestamp (for example, the time that the reference glucose data is obtained). In this embodiment, the 15 minute time delay has been chosen to account for an approximately 10 minute delay introduced by the filter used in data smoothing and an approximately 5 minute physiological time-lag (for example, the time necessary for the glucose to diffuse through a membrane(s) of a glucose sensor). In alternative embodiments, the time corresponding sensor value can be more or less than in the above-described embodiment, for example ±60 minutes. Variability in time correspondence of sensor and reference data can be attributed to, for example, a longer or shorter time delay introduced during signal estimation, or if the configuration of the glucose sensor **10** incurs a greater or lesser physiological time lag.

[0191] One advantage of integrated receiver of the preferred embodiments can be seen in the time stamp of the reference glucose data. Namely, typical implementations of the continuous glucose sensor **10**, wherein the single point glucose monitor is not integral with the receiver, the reference glucose data can be obtained at a time that is different from the time that the data is input into the receiver **30**. Thus, the user may not accurately input the “time stamp” of the reference glucose (for example, the time at which the reference glucose value was actually obtained) at the time of reference data input into the receiver. Therefore, the accuracy of the calibration is subject to human error (for example, due to inconsistencies in entering the actual time of the single point glucose test). In contrast, the preferred embodiments of the integrated receiver advantageously do no suffer from this potential inaccuracy in that the time stamp is automatically and accurately obtained at the time of single point glucose test. Additionally, the process of obtaining reference data is simplified and made convenient using the integrated receiver because of fewer loose parts (for example, cables, test strips, or the like) and less required data entry (for example, time of testing).

[0192] In some embodiments, tests are used to evaluate the best-matched pair using a reference data point against individual sensor values over a predetermined time period (for example, about 30 minutes). In one such embodiment, the reference data point is matched with sensor data points at 5-minute intervals and each matched pair is evaluated. The matched pair with the best correlation can be selected as the matched pair for data processing. In some alternative embodiments, matching a reference data point with an average of a plurality of sensor data points over a predetermined time period can be used to form a matched pair.

[0193] At block **206**, a calibration set module, forms an initial calibration set from a set of one or more matched data pairs, which are used to determine the relationship between the reference glucose data and the sensor glucose data, such as described in more detail with reference to block **208**, below.

[0194] The matched data pairs, which make up the initial calibration set, can be selected according to predetermined criteria. In some embodiments, the number (n) of data pair(s) selected for the initial calibration set is one. In other embodiments, n data pairs are selected for the initial calibration set wherein n is a function of the frequency of the received reference glucose data points. In one exemplary embodiment, six data pairs make up the initial calibration set. In another embodiment, the calibration set includes only one data pair.

[0195] In some embodiments, the data pairs are selected only within a certain glucose value threshold, for example wherein the reference glucose value is between about 40 and about 400 mg/dL. In some embodiments, the data pairs that form the initial calibration set are selected according to their time stamp.

[0196] At block **208**, a conversion function module creates a conversion function using the calibration set. The conversion function substantially defines the relationship between the reference glucose data and the sensor glucose data. A variety of known methods can be used with the preferred embodiments to create the conversion function from the calibration set. In one embodiment, wherein a plurality of matched data points form the initial calibration set, a linear least squares regression is performed on the initial calibration set such as described in more detail with reference to FIG. **10**.

[0197] At block **210**, a sensor data transformation module uses the conversion function to transform sensor data into substantially real-time glucose value estimates, also referred to as calibrated data, as sensor data is continuously (or intermittently) received from the sensor. In other words, the offset value at any given point in time can be subtracted from the raw value (for example, in counts) and divided by the slope to obtain the estimated glucose value:

$$\text{mg/dL} = \frac{(\text{rawvalue} - \text{offset})}{\text{slope}}$$

[0198] In some alternative embodiments, the sensor and/or reference glucose data are stored in a database for retrospective analysis.

[0199] At block **212**, an output module provides output to the user via the user interface. The output is representative of the estimated glucose value, which is determined by converting the sensor data into a meaningful glucose value such as described in more detail with reference to block **210**, above. User output can be in the form of a numeric estimated glucose value, an indication of directional trend of glucose concentration, and/or a graphical representation of the estimated glucose data over a period of time, for example. Other representations of the estimated glucose values are also possible, for example audio and tactile.

[0200] In one embodiment, the estimated glucose value is represented by a numeric value. In other exemplary embodiments, the user interface graphically represents the estimated glucose data trend over a predetermined time period (for example, one, three, and nine hours, respectively). In alternative embodiments, other time periods can be represented. In alternative embodiments, pictures, animation, charts, graphs, and numeric data can be selectively displayed.

[0201] Accordingly, after initial calibration of the sensor, real-time continuous glucose information can be displayed on the user interface so that the user can regularly and proactively care for his/her diabetic condition within the bounds set

by his/her physician. Both the calibrated reference glucose data from the single point glucose monitor and the sensor glucose data from the continuous glucose sensor can be displayed to the user. In an embodiment wherein the continuous glucose sensor functions as an adjunctive device to the single point glucose monitor, the user interface can display numeric reference glucose data, while showing the sensor glucose data only in a graphical representation so that the user can see the historical and present sensor trend information as well as the most recent reference glucose data value. In an embodiment wherein the continuous glucose sensor functions as a non-adjunctive device to the single point glucose monitor, the user interface can display the reference glucose data and/or the sensor glucose data. The user can toggle through menus and screens using the buttons in order to view alternate data and/or screen formats, for example.

[0202] In alternative embodiments, the conversion function is used to predict glucose values at future points in time. These predicted values can be used to alert the user of upcoming hypoglycemic or hyperglycemic events. Additionally, predicted values can be used to compensate for the time lag (for example, 15 minute time lag such as described elsewhere herein), so that an estimated glucose value displayed to the user represents the instant time, rather than a time delayed estimated value.

[0203] In some embodiments, the substantially real-time estimated glucose value, a predicted future estimated glucose value, a rate of change, and/or a directional trend of the glucose concentration is used to control the administration of a constituent to the user, including an appropriate amount and time, in order to control an aspect of the user's biological system. One such example is a closed loop glucose sensor and insulin pump, wherein the glucose data (for example, estimated glucose value, rate of change, and/or directional trend) from the glucose sensor is used to determine the amount of insulin, and time of administration, that can be given to a diabetic user to evade hyper- and hypoglycemic conditions.

[0204] FIG. 10 is a graph that illustrates one embodiment of a regression performed on a calibration set to create a conversion function such as described with reference to FIG. 9, block 208, above. In this embodiment, a linear least squares regression is performed on the initial calibration set. The x-axis represents reference glucose data; the y-axis represents sensor data. The graph pictorially illustrates regression of matched pairs 214 in the calibration set. The regression calculates a slope 216 and an offset 218, for example, using the well-known slope-intercept equation ($y=mx+b$), which defines the conversion function.

[0205] In alternative embodiments, other algorithms could be used to determine the conversion function, for example forms of linear and non-linear regression, for example fuzzy logic, neural networks, piece-wise linear regression, polynomial fit, genetic algorithms, and other pattern recognition and signal estimation techniques.

[0206] In yet other alternative embodiments, the conversion function can comprise two or more different optimal conversions because an optimal conversion at any time is dependent on one or more parameters, such as time of day, calories consumed, exercise, or glucose concentration above or below a set threshold, for example. In one such exemplary embodiment, the conversion function is adapted for the estimated glucose concentration (for example, high vs. low). For example in an implantable glucose sensor it has been observed that the cells surrounding the implant will consume

at least a small amount of glucose as it diffuses toward the glucose sensor. Assuming the cells consume substantially the same amount of glucose whether the glucose concentration is low or high, this phenomenon will have a greater effect on the concentration of glucose during low blood sugar episodes than the effect on the concentration of glucose during relatively higher blood sugar episodes. Accordingly, the conversion function can be adapted to compensate for the sensitivity differences in blood sugar level. In one implementation, the conversion function comprises two different regression lines, wherein a first regression line is applied when the estimated glucose concentration is at or below a certain threshold (for example, 150 mg/dL) and a second regression line is applied when the estimated glucose concentration is at or above a certain threshold (for example, 150 mg/dL). In one alternative implementation, a predetermined pivot of the regression line that forms the conversion function can be applied when the estimated blood is above or below a set threshold (for example, 150 mg/dL), wherein the pivot and threshold are determined from a retrospective analysis of the performance of a conversion function and its performance at a range of glucose concentrations. In another implementation, the regression line that forms the conversion function is pivoted about a point in order to comply with clinical acceptability standards (for example, Clarke Error Grid, Consensus Grid, mean absolute relative difference, or other clinical cost function) and/or physiological parameters. Although only a few example implementations are described, other embodiments include numerous implementations wherein the conversion function is adaptively applied based on one or more parameters that can affect the sensitivity of the sensor data over time.

[0207] The preferred embodiments described a continuous glucose sensor and integrated receiver with single point glucose calibration that is more cost effective than conventional reference glucose monitors (for example, more cost effective than test strips). Additionally, the consistency between the similar measurement technologies used both for the continuous sensor and the single point glucose monitor increases the consistency and decreases the cause for error between the two measurements devices, yielding a more reliable, accurate device.

[0208] In some alternative embodiments similarly advantageous results can be provided that by combined continuous glucose sensor and integrated receiver configurations wherein the measurement technologies are consistent between the continuous glucose sensor and single point glucose monitor. For example, an optical, non-invasive, "continuous or quasi-continuous" glucose measurement device such as described by U.S. Pat. No. 6,049,727, which is incorporated by reference herein in its entirety, can be implanted in the body. An integrated receiver can be provided that processes sensor data and includes an optical non-invasive single point glucose monitor such as described with reference to U.S. Pat. No. 6,309,884, which is incorporated by reference herein in its entirety. Accordingly, when optical-based technology is used both for the continuous sensor and the single point glucose monitor, increased consistency and decreased cause for error between the two measurements devices exist, yielding a more reliable, accurate device. Other embodiments can be provided that utilize consistent measurement technologies between a continuous analyte sensor and a single point analyte monitor useful for calibration such as described herein and are within the spirit of the preferred embodiments.

[0209] Methods and devices that are suitable for use in conjunction with aspects of the preferred embodiments are disclosed in co-pending U.S. patent application Ser. No. 10/885,476 filed Jul. 6, 2004, and entitled "SYSTEMS AND METHODS FOR MANUFACTURE OF AN ANALYTE-MEASURING DEVICE INCLUDING A MEMBRANE SYSTEM"; U.S. patent application Ser. No. 10/842,716, filed May 10, 2004, and entitled, "MEMBRANE SYSTEMS INCORPORATING BIOACTIVE AGENTS"; co-pending U.S. patent application Ser. No. 10/838,912 filed May 3, 2004, and entitled, "IMPLANTABLE ANALYTE SENSOR"; U.S. patent application Ser. No. 10/789,359 filed Feb. 26, 2004, and entitled, "INTEGRATED DELIVERY DEVICE FOR A CONTINUOUS GLUCOSE SENSOR"; U.S. application Ser. No. 10/685,636 filed Oct. 28, 2003, and entitled, "SILICONE COMPOSITION FOR MEMBRANE SYSTEM"; U.S. application Ser. No. 10/648,849 filed Aug. 22, 2003, and entitled, "SYSTEMS AND METHODS FOR REPLACING SIGNAL ARTIFACTS IN A GLUCOSE SENSOR DATA STREAM"; U.S. application Ser. No. 10/646,333 filed Aug. 22, 2003, entitled, "OPTIMIZED SENSOR GEOMETRY FOR AN IMPLANTABLE GLUCOSE SENSOR"; U.S. application Ser. No. 10/647,065 filed Aug. 22, 2003, entitled, "POROUS MEMBRANES FOR USE WITH IMPLANTABLE DEVICES"; U.S. application Ser. No. 10/633,367 filed Aug. 1, 2003, entitled, "SYSTEM AND METHODS FOR PROCESSING ANALYTE SENSOR DATA"; U.S. Pat. No. 6,702,857 entitled "MEMBRANE FOR USE WITH IMPLANTABLE DEVICES"; U.S. application Ser. No. 09/916,711 filed Jul. 27, 2001, and entitled "SENSOR HEAD FOR USE WITH IMPLANTABLE DEVICE"; U.S. application Ser. No. 09/447,227 filed Nov. 22, 1999, and entitled "DEVICE AND METHOD FOR DETERMINING ANALYTE LEVELS"; U.S. application Ser. No. 10/153,356 filed May 22, 2002, and entitled "TECHNIQUES TO IMPROVE POLYURETHANE MEMBRANES FOR IMPLANTABLE GLUCOSE SENSORS"; U.S. application Ser. No. 09/489,588 filed Jan. 21, 2000, and entitled "DEVICE AND METHOD FOR DETERMINING ANALYTE LEVELS"; U.S. application Ser. No. 09/636,369 filed Aug. 11, 2000, and entitled "SYSTEMS AND METHODS FOR REMOTE MONITORING AND MODULATION OF MEDICAL DEVICES"; and U.S. application Ser. No. 09/916,858 filed Jul. 27, 2001, and entitled "DEVICE AND METHOD FOR DETERMINING ANALYTE LEVELS," as well as issued patents including U.S. Pat. No. 6,001,067 issued Dec. 14, 1999, and entitled "DEVICE AND METHOD FOR DETERMINING ANALYTE LEVELS"; U.S. Pat. No. 4,994,167 issued Feb. 19, 1991, and entitled "BIOLOGICAL FLUID MEASURING DEVICE"; and U.S. Pat. No. 4,757,022 filed Jul. 12, 1988, and entitled "BIOLOGICAL FLUID MEASURING DEVICE"; U.S. Appl. No. 60/489,615 filed Jul. 23, 2003, and entitled "ROLLED ELECTRODE ARRAY AND ITS METHOD FOR MANUFACTURE"; U.S. Appl. No. 60/490,010 filed Jul. 25, 2003, and entitled "INCREASING BIAS FOR OXYGEN PRODUCTION IN AN ELECTRODE ASSEMBLY"; U.S. Appl. No. 60/490,009 filed Jul. 25, 2003, and entitled "OXYGEN ENHANCING ENZYME MEMBRANE FOR ELECTROCHEMICAL SENSORS"; U.S. application Ser. No. 10/896,312 filed Jul. 21, 2004, and entitled "OXYGEN-GENERATING ELECTRODE FOR USE IN ELECTROCHEMICAL SENSORS"; U.S. application Ser. No. 10/896,637 filed Jul. 21, 2004, and entitled "ROLLED ELECTRODE ARRAY AND ITS METHOD

FOR MANUFACTURE"; U.S. application Ser. No. 10/896,772 filed Jul. 21, 2004, and entitled "INCREASING BIAS FOR OXYGEN PRODUCTION IN AN ELECTRODE ASSEMBLY"; U.S. application Ser. No. 10/896,639 filed Jul. 21, 2004, and entitled "OXYGEN ENHANCING ENZYME MEMBRANE FOR ELECTROCHEMICAL SENSORS"; U.S. application Ser. No. 10/897,377 filed Jul. 21, 2004, and entitled "ELECTROCHEMICAL SENSORS INCLUDING ELECTRODE SYSTEMS WITH INCREASED OXYGEN GENERATION". The foregoing patent applications and patents are incorporated herein by reference in their entireties.

[0210] All references cited herein are incorporated herein by reference in their entireties. To the extent publications and patents or patent applications incorporated by reference contradict the disclosure contained in the specification, the specification is intended to supersede and/or take precedence over any such contradictory material.

[0211] The term "comprising" as used herein is synonymous with "including," "containing," or "characterized by," and is inclusive or open-ended and does not exclude additional, unrecited elements or method steps.

[0212] All numbers expressing quantities of ingredients, reaction conditions, and so forth used in the specification and claims are to be understood as being modified in all instances by the term "about." Accordingly, unless indicated to the contrary, the numerical parameters set forth in the specification and attached claims are approximations that can vary depending upon the desired properties sought to be obtained by the present invention. At the very least, and not as an attempt to limit the application of the doctrine of equivalents to the scope of the claims, each numerical parameter should be construed in light of the number of significant digits and ordinary rounding approaches.

[0213] The above description discloses several methods and materials of the present invention. This invention is susceptible to modifications in the methods and materials, as well as alterations in the fabrication methods and equipment. Such modifications will become apparent to those skilled in the art from a consideration of this disclosure or practice of the invention disclosed herein. Consequently, it is not intended that this invention be limited to the specific embodiments disclosed herein, but that it cover all modifications and alternatives coming within the true scope and spirit of the invention as embodied in the attached claims.

What is claimed is:

1. An integrated system comprising:

- a continuous glucose sensor configured to continuously measure a glucose concentration in a host, wherein the continuous glucose sensor generates continuous glucose sensor data associated with the glucose concentration in the host; and
- a receiver comprising a single point glucose monitor physically attached thereto, wherein the receiver is configured to communicate with the continuous glucose sensor and to receive the continuous glucose sensor data based on a value obtained from the single point glucose monitor, and wherein the receiver is further configured to communicate with an insulin delivery device and to process and transmit insulin administration information to the insulin delivery device based at least in part on a predicted glucose concentration and a rate of change of glucose concentration.

2. The system of claim 1, wherein each of the continuous glucose sensor and the single point glucose monitor comprise

a sensing membrane comprising an enzyme domain, and wherein the enzyme domain of the sensing membrane of the continuous glucose sensor and the enzyme domain of the sensing membrane of the single point glucose monitor are substantially the same.

3. The system of claim 1, wherein the single point glucose monitor is configured to receive a single use test strip.

4. The system of claim 1, wherein the receiver comprises programming to control time and/or amount of administration of insulin to the host.

5. The system of claim 1, further comprising an insulin delivery device.

6. The system of claim 5, wherein the insulin delivery device comprises an insulin pump, and wherein the receiver is further configured to process and transmit insulin administration information to the insulin delivery device based at least in part the glucose concentration measured by the continuous glucose sensor.

7. The system of claim 1, wherein the programming to control time and/or amount of administration of insulin to the host comprises programming to control administration of insulin to the host based at least in part on the rate of change of the continuous glucose sensor data.

8. The system of claim 1, wherein the programming to control time and/or amount of administration of insulin to the host comprises programming to control administration of insulin to the host based at least in part on the directional trend of the continuous glucose sensor data.

9. The system of claim 1, wherein the receiver is configured to monitor the continuous glucose sensor data to adaptively determine a time for requesting a biological sample.

10. The system of claim 1, wherein the receiver comprises a user interface, and wherein the receiver is configured to prompt the user, via the user interface, to provide a biological sample to the single point glucose monitor at predetermined intervals.

11. The system of claim 1, wherein the receiver comprises a user interface, and wherein the receiver is configured to prompt the user, via the user interface, to provide a biological sample to the single point glucose monitor based upon one or more events.

12. The system of claim 11, wherein the one or more events comprise one or more events selected from the group consisting of meals, exercise, large excursions in glucose levels, faulty data readings, and interrupted data readings.

13. The system of claim 1, wherein receiver is configured to compare the value obtained from the single point glucose monitor with one or more acceptability parameters.

14. The system of claim 1, wherein the receiver comprises a user interface, and wherein the receiver is configured to display the value obtained from the single point glucose monitor and the continuous glucose sensor data from the continuous glucose sensor on the user interface.

15. The system of claim 1, wherein the receiver comprises a user interface, and wherein the receiver is configured to simultaneously display the single point value and a graphical representation of the continuous glucose sensor data.

16. The system of claim 1, wherein the receiver comprises a user interface, and wherein the receiver is configured to selectively display the single point value and the continuous glucose sensor data responsive to user interaction.

17. The system of claim 1, wherein the receiver comprises a processor module configured to automatically receive the single point glucose sensor data without user interaction.

18. The system of claim 1, wherein the predicted value is an estimated glucose value configured to compensate for a time lag.

19. The system of claim 1, wherein the receiver is configured to calibrate the continuous glucose sensor data.

20. The system of claim 1, further comprising electronics configured to calibrate the continuous glucose sensor data.

* * * * *