

Jan. 2, 1923.

1,440,386

C. L. HAWES.
POLISHING AND GRINDING MACHINE.
FILED NOV. 26, 1919.

2 SHEETS-SHEET 1

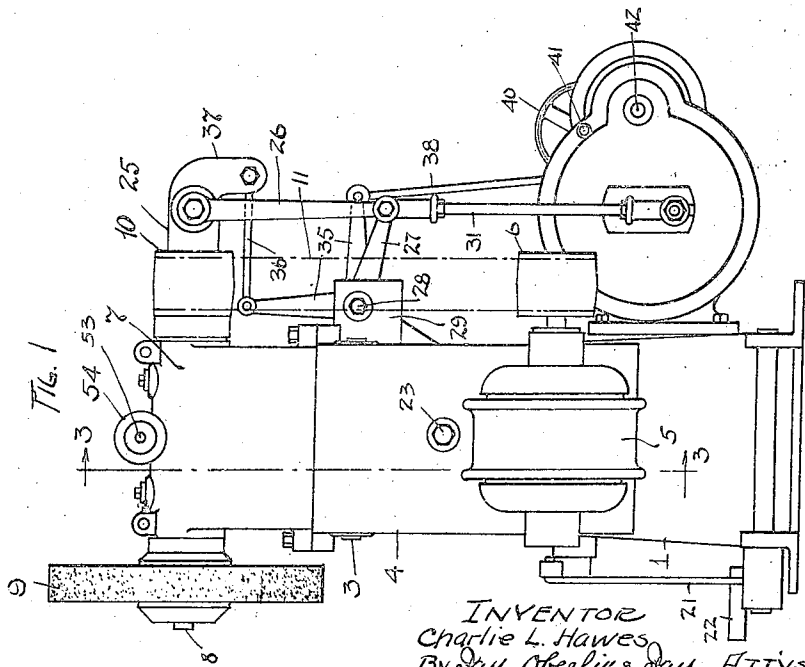
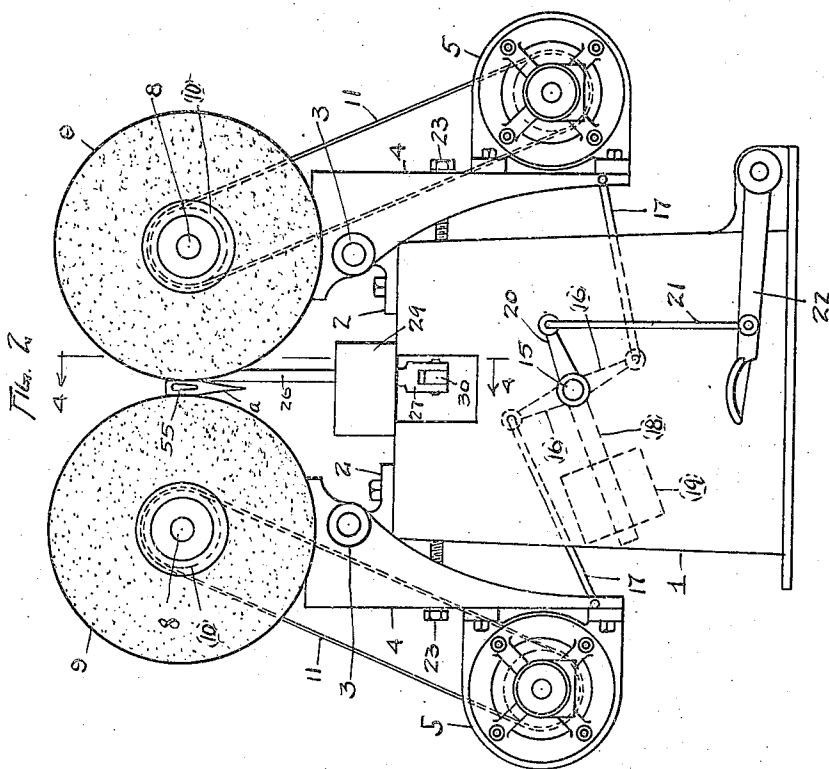

INVENTOR
Charlie L. Hawes
By Day, Oberlin & Day ATTYS.

Jan. 2, 1923.

1,440,386

C. L. HAWES.
POLISHING AND GRINDING MACHINE.
FILED NOV. 26, 1919.

2 SHEETS-SHEET 2

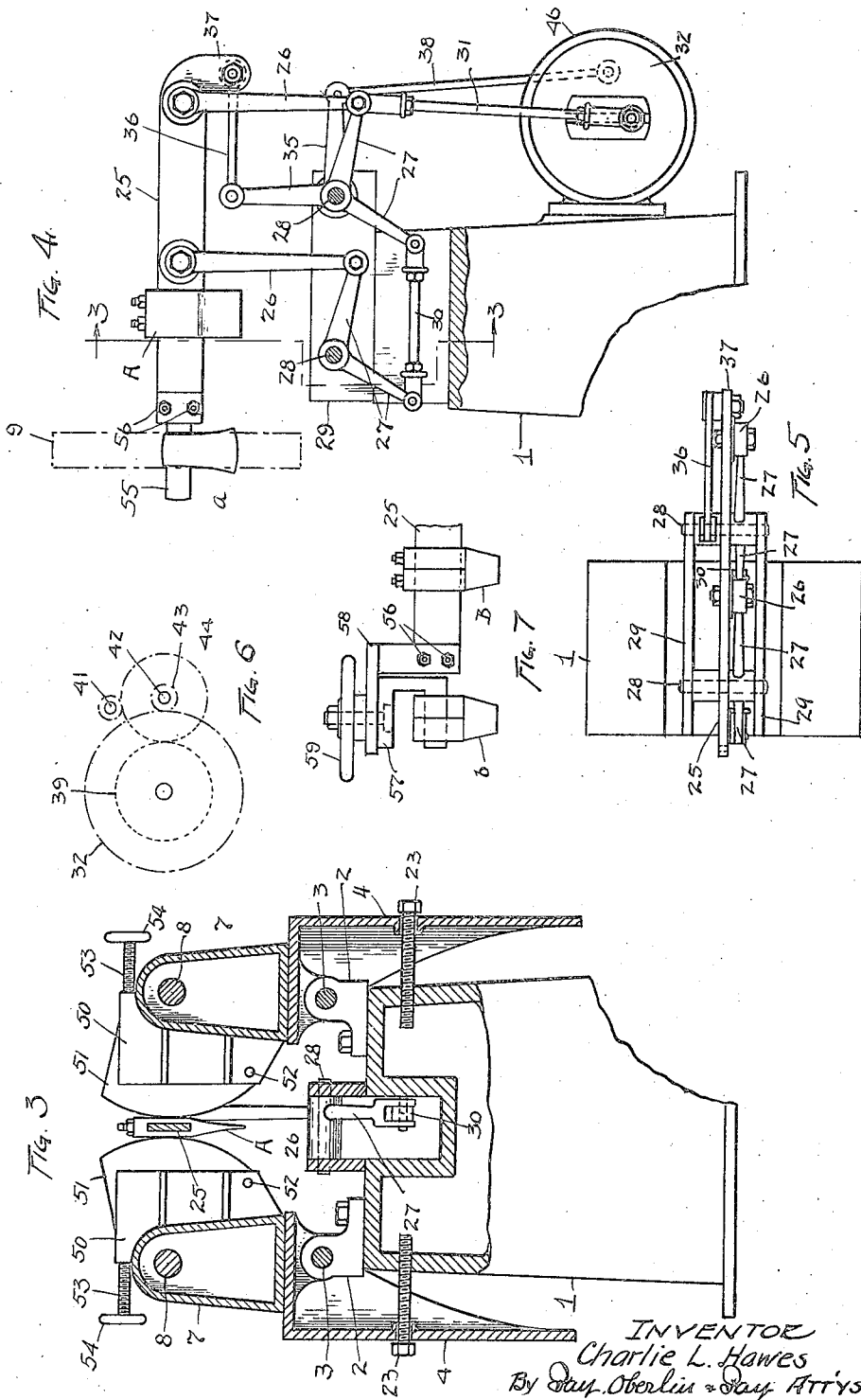

INVENTOR
Charlie L. Hawes
By Day Oberlin & Day Att'ys

UNITED STATES PATENT OFFICE.

CHARLIE L. HAWES, OF ASHTABULA, OHIO.

POLISHING AND GRINDING MACHINE.

Application filed November 26, 1919. Serial No. 340,709.

To all whom it may concern:

Be it known that I, CHARLIE L. HAWES, a citizen of the United States, and a resident of Ashtabula, county of Ashtabula, and State of Ohio, have invented a new and useful Improvement in Polishing and Grinding Machines, of which the following is a specification, the principle of the invention being herein explained and the best mode in which I have contemplated applying that principle, so as to distinguish it from other inventions.

The object of the present invention is to provide a polishing or grinding machine of the dual opposed wheel type, which will be capable of automatically operating on articles such as axes, hatchets, and the like. For operation on articles of this character, the grinding or polishing wheels require to be more or less closely positioned as different portions of the article are presented. Means on the order of a template are accordingly provided, whereby the position of the two wheels is simultaneously automatically controlled so as to cause them to grind in the desired plane or planes, and thus conform with the surface of the article being finished. In the case of an ax or hatchet, the two surfaces of the article are symmetrical, and the adjustment of the two wheels accordingly is in unison but in opposite direction. This, however, need not necessarily be the case, and furthermore, by an adaptation, articles of circular cross-section, such as certain forms of hammer-heads, for example, which constitute frustra of cones or pyramids, may be ground with equal facility.

To the accomplishment of the foregoing and related ends, the invention, then, consists of the means hereinafter fully described and particularly pointed out in the claims, the annexed drawings and the following description setting forth in detail certain mechanism embodying the invention, such disclosed means constituting, however, but several of the various mechanical forms in which the principle of the invention may be used.

In said annexed drawings:—

Fig. 1 is a side elevation of a polishing or grinding machine embodying my present improvements as arranged specifically for grinding ax-heads; Fig. 2 is a front elevation of the same; Fig. 3 is a transverse section of the machine taken on the plane in-

dicated by the line 3—3, Fig. 1; Fig. 4 is a central longitudinal section thereof, taken on the plane indicated by the line 4—4, Fig. 2; Fig. 5 is a plan view of a portion of the machine; Fig. 6 is a diagrammatic representation of a train of gearing that forms a feature of the machine; and Fig. 7 is a side elevation of a detail showing a modification in construction.

The various operative parts of the machine, it will be seen, are supported on a suitable upstanding frame or base 1 of substantial construction. Mounted on the top of such base are two transversely spaced bearing members 2, 2, to which are pivotally attached, about parallel axes 3, 3 a pair of oscillatory arms 4, 4, provided with rectangularly related faces, the longer of which is disposed in an approximately vertical plane, the other being approximately horizontal. Vertically adjustably secured to such longer face of each arm 4 is a suitable self-contained electric motor 5, the spindle of which carries on its rear end a belt pulley 6; while transversely adjustably mounted on the upper approximately horizontal face of each arm is a housing 7 wherein is journaled the spindle 8 of one of the polishing or grinding wheels 9. Such wheel is mounted on the front end of its spindle, the rear end being provided with a pulley 10 aligned with pulley 6 and connected to be driven from the latter by the belt 11.

The particular construction of the wheels 9 is a matter of indifference so far as the essential features of the invention are concerned, but for grinding articles such as those hereinbefore referred to, such wheels will ordinarily be of emery or like solid abrasive material, while for buffing or polishing, they will be of any material usually employed in this connection.

The motors 5, by reason of their weight and disposition with respect to the pivotal axes 3 of the frame 4 to which they are attached, will tend to swing the lower ends of such frames inwardly, and such inward movement of the lower ends of the arms, however produced, will obviously swing the spindles 8, and thus the wheels 9, outwardly or apart from each other. In order to overcome the effect of the weight of the motors and normally to cause the wheels to tend to move in a contrary direction, i. e. towards each other, a rock shaft 15 is journaled, preferably centrally, in base 1, and pro-

vided with cross arms 16 connected by means of links 17 with the lower ends of the respective frames 4. Another arm 18 attached to said shaft 15 at right angles to the arms 16 is provided with a counter-weight 19 that is heavy enough to overcome the aforesaid effect of the motors and so actually tend to force the lower ends of the arms 4 apart and move the wheels 9 towards each other, such counter-weight being adjustable to vary pressure. Still another arm 20 is attached to the shaft 15 projecting in a direction opposite to that of arm 18, and is connected by means of a link 21 with a foot lever 22, the result being that by depressing such lever the shaft may be rocked in a direction to move the lower ends of the arms 4 inwardly, and thus separate the wheels 9, to permit changing the work. Outward movement of the lower arm-ends under the influence of counter-weight 19 is limited by means of adjustable stops 23 whereby the wheels may be allowed to approach each other as closely as desired without actually contacting.

The holder for the work, which consists as aforesaid of ax-heads in the case of the specific machine in hand, together with associated operating mechanism, is best shown in Figs. 3, 4 and 5. The main element of such holder is a bar 25 that is supported so as to be both vertically and longitudinally movable in a fixed plane passing between the inwardly directed faces of the two wheels 9. Such bar 25, in other words, is disposed parallel with the axes of the spindles 8, and, in order that it may be capable of movement in the fashion just described, it is supported by means of parallel links 26 from the approximately horizontal arms of corresponding bell cranks 27 which are pivotally mounted about axes 28 in a suitable framework 29 on the top of base 1. The depending arms of bell cranks 27 are connected by means of an adjustable link or rod 30 so that the two cranks will move in unison to elevate and depress the bar 25, such movement being derived through the medium of a connecting rod 31 attached at its upper end to one of said bell cranks and at its lower end eccentrically attached to a rotatable member 32.

Pivotally mounted upon the same axis 28 as one of the bell cranks 27, is another bell crank 35 having its one arm directed partially vertically, and connected by means of a horizontal lever 36 with the depending rear end 37 of bar 25. The other arm of said bell crank 35 is connected by means of a link 38 with a rotatable member 39 coaxial with member 32. The effect of oscillation of bell crank 35 will obviously be to impart a to-and-fro motion to bar 25 longitudinally of its axis, and that irrespective of whether said bar is being simultaneously

raised or lowered, due to the oscillation of the bell cranks 27.

The two members 32 and 39, from which motion is respectively communicated to the pair of bell cranks 27 that thus raise and lower bar 25, and to the bell crank 35 that longitudinally reciprocates said bar, are intended to be rotated at different speeds, the former considerably more slowly than the latter, so that, as the bar rises or falls, it will be moved longitudinally back and forth a plurality of times. Various driving connections for the members 32 and 39 may be employed to secure the stated result; but in the construction illustrated, power is intended to be applied through a pulley 40 to a driving shaft 41, and thence to a second shaft 42 intergeared with said shaft 41, such second shaft carrying a small gear 43 that engages member 32, and a larger gear 44 that engages member 39, both said members being provided with appropriate gear teeth, in effect constituting of them gears themselves. These two members are conveniently assembled and held face to face in a suitable housing 46 attached to the rear face of base 1, as shown in Figs. 1 and 4.

Fixedly attached to the respective housings 7 are inwardly directed guides 50, between which are held plates 51, whose inwardly directed faces are of segmental form. These plates 51 are oscillatorily attached at their lower ends to the guides 50, about axes 52, and are angularly adjustable about such axis by means of screws 53 provided with suitable hand-wheels 54 for convenience of operation. Such plates 51 are designed to simultaneously contact with opposite faces of a master form or template A suitably secured to the bar 25, and, as such bar rises and falls, to correspondingly force said plates apart or allow them to approach each other, it being understood that, under the action of counter-weight 19, the upper ends of the arms 4 normally tend to swing towards each other and similarly to move the parts mounted thereon, including housings 7 and these plates 51. The latter will be adjusted to bring their inwardly directed edges into position corresponding with the juxtaposed faces of wheels 9, so that, as the plates are moved apart or brought together, the wheels will be similarly moved and cause their juxtaposed faces to follow exactly the path of movement of the corresponding faces of plates 51.

For the purpose of actually receiving and holding the article to be operated upon, in this case an ax-head *a*, a suitable member 55 is detachably secured to the forward end of bar 25, as by means of bolts 56. The heads *a* are successively slipped onto such projecting member, and, after grinding, removed therefrom by the operator.

The general operation of the machine

should be readily evident. Assuming it is desired to place an ax-head on member 55, the wheels 9 are separated by depressing foot lever 22. The member 25 should be in its lowermost position when this is done, and approximately midway between the limits of its endwise movement. If, then, the article *a* be located centrally with respect to the grinding faces of wheels 9, when the latter are allowed to contact therewith by releasing pedal 22, the position of parts will be substantially as illustrated in Figs. 2 and 4. The remainder of the operation is automatic; in other words, the article is reciprocated back and forth across the faces of the wheels at the same time that it is elevated. In the course of such movement of the article the wheels follow its contour, as they are at all times guided in their relative position by the plates 51 which contact with the master form or template A. The operation is complete when the lower cutting edge of the article is finally raised out of contact with the wheels.

25. A machine of the foregoing construction can be readily adapted to grind a plurality of tapering faces forming a frustum of a pyramid or a conical face forming the frustum of a cone, such as found in certain styles of hammers and sledges, by providing means for rotating the article being operated upon about a vertical axis. In Fig. 7, I show a simple form of holder 57 intended to replace member 55 on the forward end of bar 25, such holder comprising a rotatable element on which the hammer-head *b* or similar article is mounted in place of a straight projection 55. A bracket 58 serves thus rotatably to support said holder on the forward end of the bar 25, and a hand-wheel 59 or equivalent means enables the operator to rotate the holder either continuously or step by step, as may be desired. Of course a correspondingly shaped master form B requires to be substituted for form A in order that the grinding wheels may be guided to properly contact with the surface of the article being operated upon.

Other modes of applying the principle of my invention may be employed instead of the one explained, change being made as regards the mechanism herein disclosed, provided the means stated by any of the following claims or the equivalent of such stated means be employed.

I therefore particularly point out and distinctly claim as my invention:

1. In a machine of the character described, the combination with a suitable base; of two spindles mounted so as to be movable in unison towards and from each other and respectively provided with a polishing or grinding wheel; a pivoted work-holding member bodily movable in a fixed plane between said spindles; means connected with said mem-

ber for shifting the same horizontally; means connected with said member for shifting the same vertically, said combined shifting means comprising the sole support of said member; and means adapted to vary the relative positions of said spindles in unison with the movement of said member.

2. In a machine of the character described, the combination with a suitable base; of two spindles mounted so as to be movable in unison towards and from each other and respectively provided with a polishing or grinding wheel; a pivoted work-holding member bodily movable in a fixed plane between said spindles both parallel and transversely of the axes of said spindles; and a template carried by said member adapted to vary the relative positions of said spindles as said member is moved.

3. In a machine of the character described, the combination with a suitable base; of two spindles mounted so as to be movable in unison towards and from each other and respectively provided with a polishing or grinding wheel; a work-holding member pivoted for movement in a fixed plane between said spindles both parallel with and transversely of the axes of said spindles; a template carried by said member; and guides carried by said spindles and held in contact with said template so as to vary the relative positions of said spindles as said member is moved.

4. In a machine of the character described, the combination with a suitable base; of two spindles mounted so as to be movable in unison towards and from each other and respectively provided with a polishing or grinding wheel; a work-holding member pivoted for movement in a fixed plane between said spindles both parallel with and transversely of the axes of said spindles; a template carried by said member; and adjustable guides carried by said spindles and held in contact with said template so as to vary the relative positions of said spindles as said member is moved.

5. In a machine of the character described, the combination with a suitable base; of two spindles mounted so as to be movable in unison towards and from each other and respectively provided with a polishing or grinding wheel; a pivoted work-holding member bodily movable in a fixed plane between said spindles both parallel with and transversely of the axes of said spindles; and means adapted to move said member in each such direction independently of the other, and conjointly connected to and supporting said member.

6. In a machine of the character described, the combination with a suitable base; of two spindles mounted so as to be movable in unison towards and from each other and respectively provided with a polishing or grinding wheel; a pivoted work-

holding member bodily movable in a fixed plane between said spindles both parallel with and transversely of the axes of said spindles; and means adapted to move said member in each such direction independently of the other and at different rates of speed, and conjointly connected to and supporting said member.

7. In a machine of the character described, the combination with a suitable base; of two spindles mounted so as to be movable in unison towards and from each other and respectively provided with a polishing or grinding wheel; a member disposed parallel with said spindles and adapted to support the article to be operated on between said wheels; cranks pivotal about axes transversely of said spindles; and links connecting said cranks with said member, whereby the latter is movable both up and down and longitudinally.

8. In a machine of the character described, the combination with a suitable base; of two spindles mounted so as to be movable in unison towards and from each other and respectively provided with a polishing or grinding wheel; a member disposed parallel with said spindles and adapted to support the article to be operated on between said wheels; interconnected bell-cranks pivotal about axes transversely of said spindles; links connecting said bell-cranks with said member, whereby the latter is movable both up and down and longitudinally; and means adapted to rock said bell-cranks.

9. In a machine of the character described, the combination with a suitable base; of two spindles mounted so as to be movable in unison towards and from each other and respectively provided with a polishing or grinding wheel; a member disposed parallel with said spindles and adapted to support the article to be operated on between said wheels; interconnected bell-cranks pivotal about axes transversely of said spindles; links connecting said bell-cranks with said member; means adapted to rock said bell-cranks whereby said member is moved up and down; and other means connected with said member to move the same longitudinally.

10. In a machine of the character described, the combination with a suitable base; of two spindles mounted so as to be movable in unison towards and from each other and respectively provided with a polishing or grinding wheel; a member disposed parallel with said spindles and adapted to support the article to be operated on between said wheels; interconnected bell-cranks pivotal about axes transversely of said spindles; links connecting said bell-cranks with said member; means adapted to rock said bell-cranks whereby said member is moved up and down; and other means con-

nected with said member to move the same longitudinally, said last named means operating more frequently than those first-named.

11. In a machine of the character described, the combination with a suitable base; of two arms oscillatorily supported thereon about spaced parallel axes; a spindle mounted on each inch arm adapted to receive a polishing or grinding wheel; means tending to actuate said arms to move said spindles, and thus said wheels, towards each other; a work-holding member movable in a fixed plane between said spindles both parallel therewith and transversely of such axes; and means controlling the action of said arm-actuating means in unison with the movement of said member.

12. In a machine of the character described, the combination with a suitable base; of two arms oscillatorily supported thereon about spaced parallel axes; a spindle mounted on each such arm adapted to receive a polishing or grinding wheel; means tending to actuate said arms to move said spindles, and thus said wheels, towards each other; a work-holding member movable in a fixed plane between said spindles both parallel therewith and transversely of such axes; and a template carried by said member and adapted to control the action of said arm-actuating means in unison with the movement of said member.

13. In a machine of the character described, the combination with a suitable base; of two arms oscillatorily supported thereon about spaced parallel axes; a spindle mounted on each such arm adapted to receive a polishing or grinding wheel; means tending to actuate said arms to move said spindles, and thus said wheels, towards each other; a work-holding member movable in a fixed plane between said spindles both parallel therewith and transversely of such axes; a template carried by said member; and guides carried by said arms and serving by contact with said template to control the action of said arm-actuating means in unison with the movement of said member.

14. In a machine of the character described, the combination with a suitable base; of two arms oscillatorily supported thereon about spaced parallel axes; a spindle mounted on each such arm adapted to receive a polishing or grinding wheel; means tending to actuate said arms to move said spindles, and thus said wheels, toward each other; a work-holding member movable in a fixed plane between said spindles both parallel therewith and transversely of such axes; a template carried by said member; and guides in the form of plates transversely adjustably secured to said arms and serving by contact with said template to control the action of said arm-actuating means

in unison with the movement of said member.

15. In a machine of the character described, the combination with a suitable base; of two arms oscillatorily supported thereon about spaced parallel axes; a spindle mounted on each such arm adapted to receive a polishing or grinding wheel; means tending to actuate said arms to move said spindles, and thus said wheels, towards each other; a work-holding member movable in a fixed plane between said spindles both parallel therewith and transversely of such axes; a template carried by said member; and guides in the form of plates oscillatorily secured to said arms about axes parallel with the axes of the latter, said guides having curved faces adapted by contact with said template to control the action of said arm-actuating means in unison with the movement of said member.

16. In a machine of the character described, the combination with a suitable base; of two spindles mounted so as to be movable in unison towards and from each other and respectively provided with a polishing or grinding wheel; and a work-holding member bodily movable in a fixed plane between said spindles, said member being

also rotatable about an axis lying in such plane.

17. In a machine of the character described, the combination with a suitable base; of two spindles mounted so as to be movable in unison towards and from each other and respectively provided with a polishing or grinding wheel; and a work-holding member bodily movable in a fixed plane between said spindles both parallel with and transversely of the axes of said spindles, said member being also rotatable about an axis lying in such plane.

18. In a machine of the character described, the combination with a suitable base; of two spindles mounted so as to be movable in unison towards and from each other and respectively provided with a polishing or grinding wheel; and a work-holding member bodily movable in a fixed plane between said spindles both parallel with and transversely of the axes of said spindles, said member being also rotatable about an axis lying in such plane and parallel with one such direction of movement.

Signed by me, this 25th day of November, 1919.

CHARLIE L. HAWES.