



US00D545693S

(12) **United States Design Patent**
Iwasaki

(10) **Patent No.:** **US D545,693 S**

(45) **Date of Patent:** **** Jul. 3, 2007**

(54) **CLOCK**

(57) **CLAIM**

(75) Inventor: **Kouji Iwasaki**, Tokyo (JP)

The ornamental design for a clock, as shown and described.

(73) Assignee: **Idea International Co., Ltd.**, Tokyo (JP)

(**) Term: **14 Years**

(21) Appl. No.: **29/209,785**

(22) Filed: **Jul. 22, 2004**

(51) **LOC (8) Cl.** **10-01**

(52) **U.S. Cl.** **D10/15**

(58) **Field of Classification Search** D10/1-4,
D10/6-8, 10, 15, 16, 23-27, 21, 123, 126,
D10/43, 54; 368/10, 179-183, 276, 316,
368/317, 228, 232, 239-242; 455/456, 414.1,
455/550

See application file for complete search history.

(56) **References Cited**

U.S. PATENT DOCUMENTS

D368,227 S * 3/1996 Danko et al. D10/5
6,393,306 B1 * 5/2002 Hobbi 455/566

* cited by examiner

Primary Examiner—Robert M. Spear

Assistant Examiner—George D. Kirschbaum

(74) *Attorney, Agent, or Firm*—Wenderoth, Lind & Ponack,
L.L.P.

DESCRIPTION

FIG. 1 is a front elevation view of a clock showing my new design, when the clock is in a powered-on condition;

FIG. 2 is a rear elevation view thereof;

FIG. 3 is a top plan view thereof;

FIG. 4 is a bottom plan thereof;

FIG. 5 is a right end view thereof, and the left end view is a mirror image of the right end view;

FIG. 6 is a front perspective view thereof, when the clock is in the powered-on condition;

FIG. 7 is a front perspective view thereof, when the clock is in the powered-off condition;

FIG. 8 is a sectional view thereof taken along line 8—8 of FIG. 2; and,

FIG. 9 is a sectional view thereof taken along line 9—9 of FIG. 2.

The broken lines shown in FIGS. 1, 6, 8 and 9 are for illustrative purposes only and form no part of the claimed design.

1 Claim, 4 Drawing Sheets

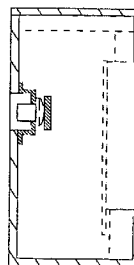
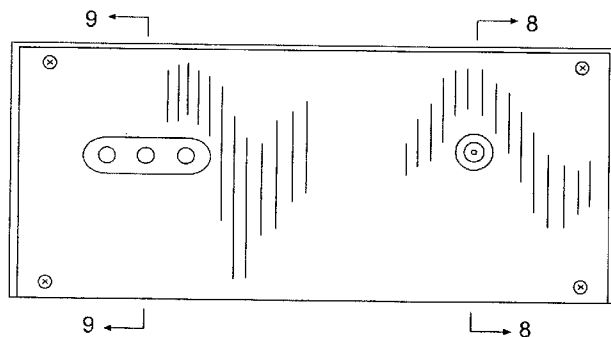
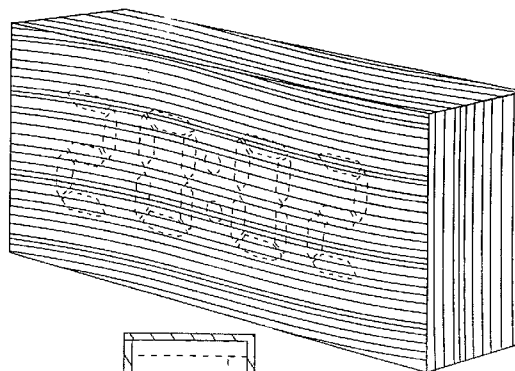
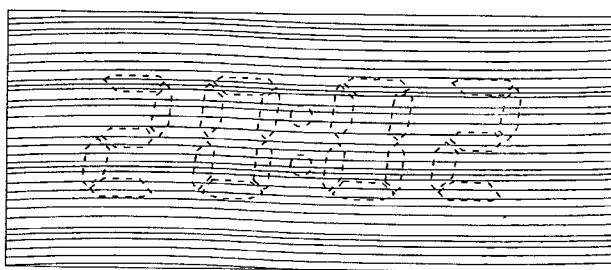

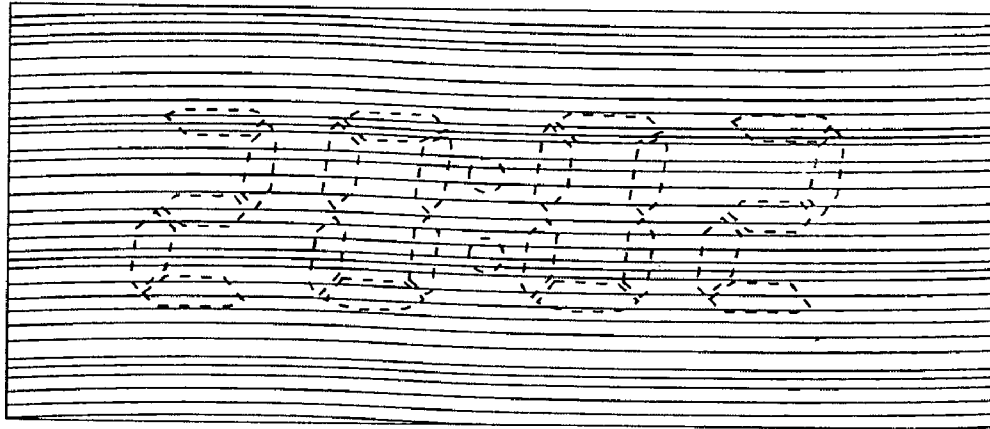

FIG. 1

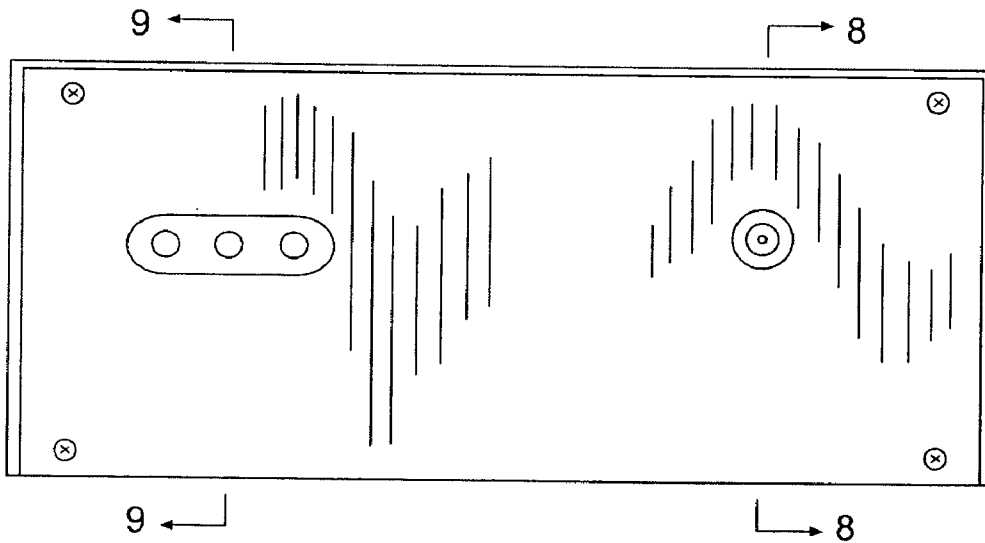

FIG. 2

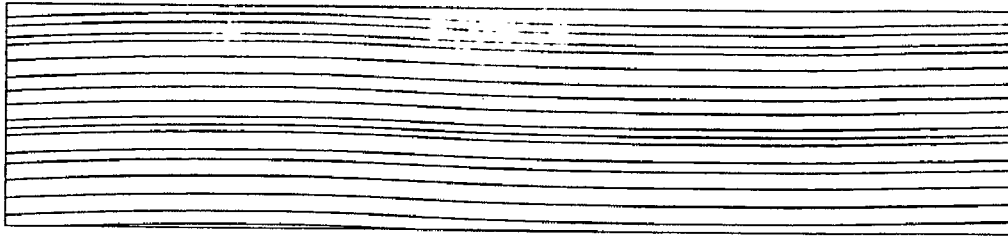

FIG. 3

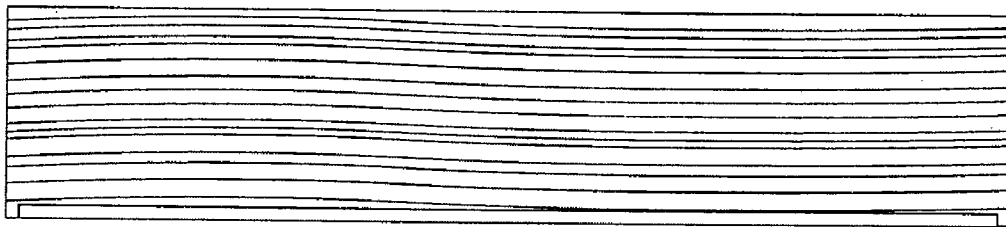

FIG. 4

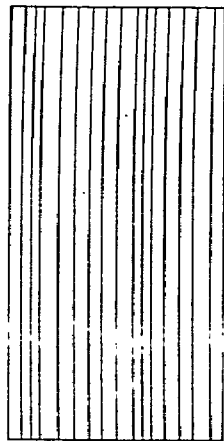

FIG. 5

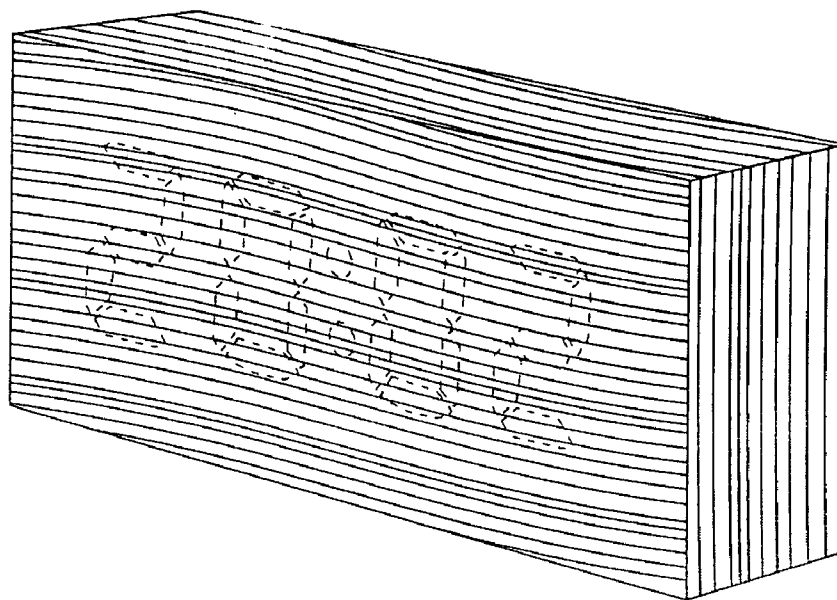

FIG. 6

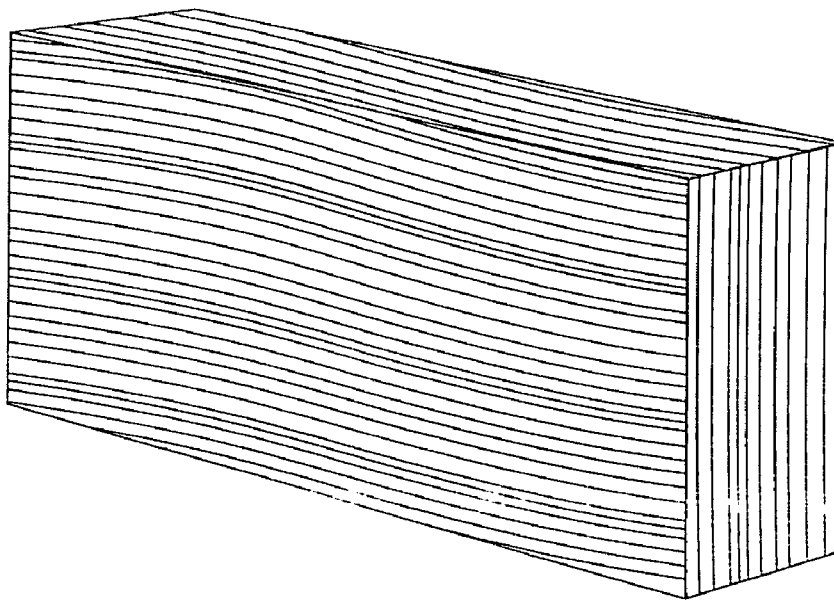

FIG. 7

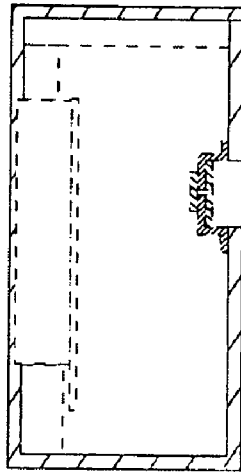

FIG. 8

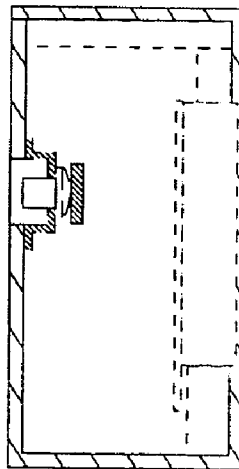

FIG. 9