

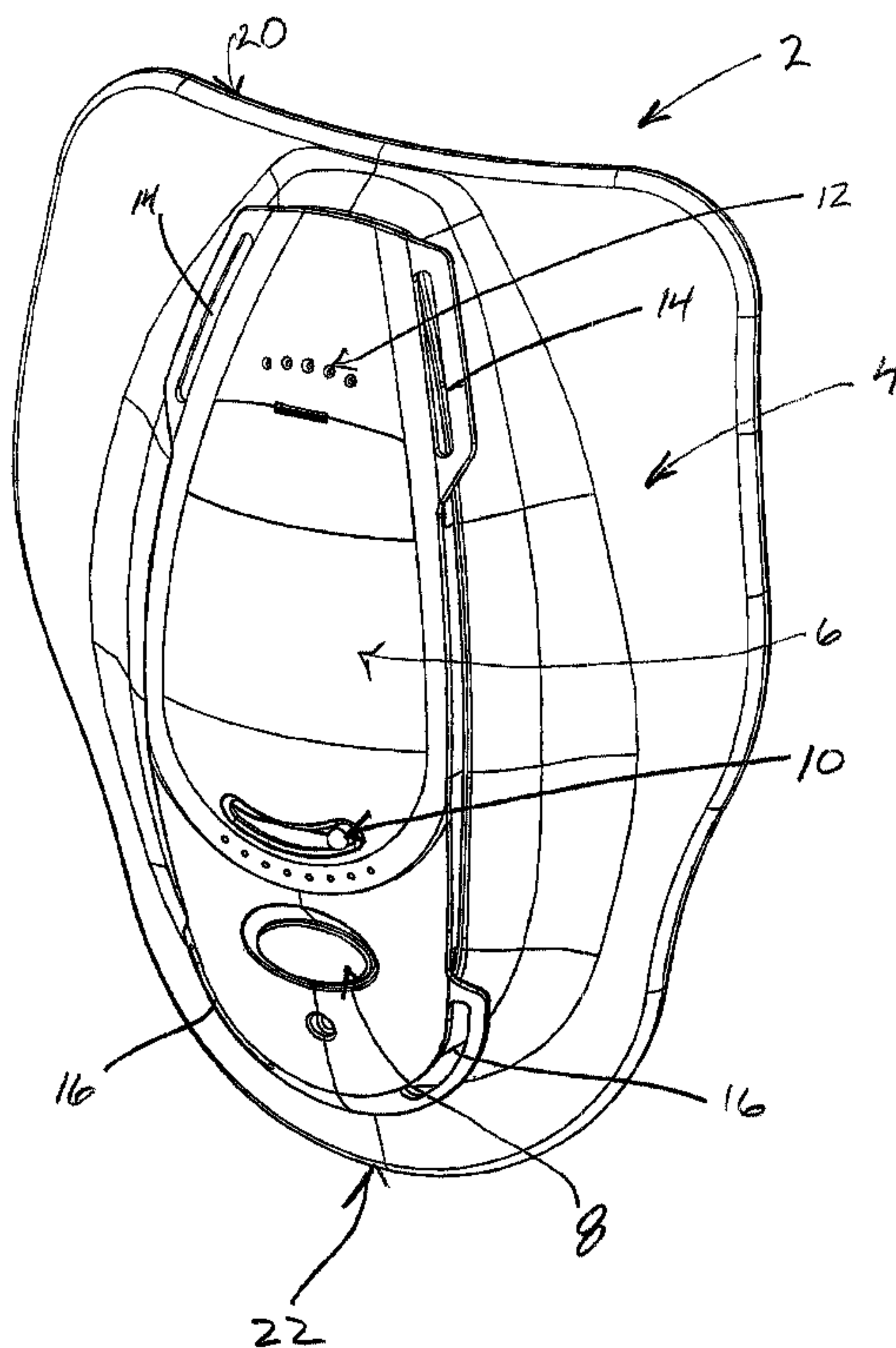

(22) Date de dépôt/Filing Date: 2002/12/18
(41) Mise à la disp. pub./Open to Public Insp.: 2004/06/18

(51) Cl.Int.⁷/Int.Cl.⁷ A63B 69/36
(71) Demandeur/Applicant:
SWINGSCOPE INC., CA
(72) Inventeurs/Inventors:
CURKOVIC, JOSEPH A., CA;
MARINI, CONRAD M., CA;
MAZZOTTA, PAUL, CA
(74) Agent: DENNISON ASSOCIATES

(54) Titre : AIDE D'ELAN DE GOLF
(54) Title: GOLF SWING AID



(57) **Abrégé/Abstract:**

The golf swing aid is worn by a golfer and senses improper movement of the hip joint of the golfer during a golf swing. The aid produces a user perceptible signal when the movement has exceeded a set threshold. The aid is suitable as a practice aid or as a teaching aid for an instruction lesson.

- 20 -

ABSTRACT OF THE DISCLOSURE

The golf swing aid is worn by a golfer and senses improper movement of the hip joint of the golfer during a
5 golf swing. The aid produces a user perceptible signal when the movement has exceeded a set threshold. The aid is suitable as a practice aid or as a teaching aid for an instruction lesson.

GOLF SWING AID**FIELD OF THE INVENTION**

5 The present invention relates to golf aids and in particular relates to a golf swing aid which senses improper hip and leg movement during a golf swing.

BACKGROUND OF THE INVENTION

10

 There are a host of prior art golf aids designed to assist a golfer in performing on a consistent basis an effective golf swing. These prior art golf aids can basically be divided between golf aids which are fixed or
15 require part thereof fixed relative to the ground which limit or monitor the golfers movement and a second group of golf aids which are worn by the user and generally tend to sense momentum. Some golf aids used as support which senses movement of two parts either side of a
20 joint. United States Patent 4,222,569 and United States Patent 5,823,980 disclose such an arrangement to be placed over a wrist. It is also known to place a similar arrangement over a hip joint for mechanically producing an audible sound if stress limit is exceeded. This
25 device is different to position and is different to adjust for different body types and different swings associated with different clubs.

 One of the critical components of an effective
30 golf swing is proper golf posture and the torquing of the body during the back swing by rotating the shoulders and hips using the spine as the axis of rotation. The body is wound or torqued during the initial back swing and is then released during the swing of the golf club. In
35 addition to the proper leg, hip and shoulder positions, the movement of the arms is critical.

- 2 -

The present invention is directed to a device which is worn by a golfer and allows him to develop the appropriate torquing of the body during the back-swing and the release of this torque during the swinging of golf club. The device senses improper movement of the legs, hips and shoulders which result in a change in movement of the body adjacent the user's femur and hip joint. The device allows for sensing of the movement during the back swing as well as during the swing of the golf club.

SUMMARY OF THE PRESENT INVENTION

A golf swing aid according to the present invention is to be worn by the user and comprises a first attachment arrangement for securing of the aid about the waist of user such that the aid hangs downwardly over the hip of the user. A second attachment arrangement secures the aid to the leg of the user. A lever arrangement secured between the first and second attachment and includes an electronic sensor positionable adjacent a user's hip joint for sensing undesirable movement of the femur and/or hip joint. The sensor electronically produces a user perceptible signal when the undesired movement associated with the hip joint exceeds a preset threshold.

According to a preferred aspect of the invention, the golf swing aid includes an adjustable threshold whereby the user can select the tolerated movement associated with the hip joint before the generation of the user perceptible signal. This arrangement is particularly desirable in that the user can vary the amount of movement that the device will tolerate. Furthermore, it allows the user to customize the actuator

to his body specifics. Different body types have different shapes in the hip region and the adjustable setting of the sensor allows the user to customize the device for his own needs. This adjustment also allows
5 the user to vary the amount of movement that is tolerated before actuation. This allows the user to adjust the device for different types of swings. For example, when hitting a driver more movement can be tolerated relative to the amount of movement associated with a more limited
10 swing such as the swing for a 9-iron or a wedge. Thus the user can adjust the device to accommodate these different functional requirements. The adjustable threshold also allows the user to set the device according to the desired response of the user. The user
15 may initially want a greater tolerance when the swing is not as consistent. The user as he develops a more consistent swing can reduce the degree of tolerance to reduce variations further.

20 According to a different aspect of the invention the user perceptible signal can be varied and the device allows for selection of the signal from a group consisting of a vibratory signal, a visual signal and an audible signal.

25

In yet a further aspect of the invention the golf swing aid allows a combination of user perceptible signals to be generated.

30

According to yet another further aspect of the invention the golf swing aid includes a resilient foam outer body secured to one side of the lever arrangement. The foam body has an outer peripheral edge surrounding a sensor receiving cavity. The sensor is located in the
35 cavity in a recessed manner.

In yet a further aspect of the invention the sensor includes a large circular actuator which is moveable against a spring bias.

5 In yet a further aspect of the invention the lever arrangement is an elongated plastic housing. The housing contains the actuator, electrical circuit means for the actuator and a user perceptible generator and a battery.

10 In yet a further aspect of the invention the foam body is secured to one side of the plastic housing.

In yet a further aspect of the invention the foam body is molded onto the plastic housing.

15

In yet a further aspect of the invention the plastic housing includes a slide member for adjusting and maintaining the position of the actuator within the cavity.

20

A method for detecting excessive movement according to the present invention detects excessive movement associated with the hip joint during a golf swing. The method comprises placing an electrical
25 sensing arrangement adjacent the hip joint for actuation by excessive movement of the femur during the golf swing. The method includes securing this sensing arrangement to the user above and below the hip joint and producing a user perceptible signal when excessive movement of the
30 hip joint has been detected.

According to an aspect of the invention the method includes the step of adjusting the electrical sensing arrangement to provide a user set tolerance of the amount
35 of excessive movement of the hip that is permitted before producing the user perceptible signal.

In yet a further aspect of the invention the method includes the step of the user perceptible signal being selected from a plurality of user perceptible signals.

In a further aspect of the invention the method is used to detect at least excessive lateral slide of the hips during a golf swing.

In yet a further aspect of the invention the method is used to detect during a golf swing excessive lateral slide of the hips or excessive angling of the hips or a combination of these movements.

15

BRIEF DESCRIPTION OF THE DRAWINGS

The above as well as other advantages and features of the present invention will be described in greater detail according to the preferred embodiments of the present invention in which;

20

Figure 1 is a perspective view of the golf swing aid;

25

Figure 2 is an exploded perspective view of the golf swing aid;

30

Figure 3 is a top view of the golf swing side;

Figure 4 is a bottom perspective view of the golf swing aid;

35

Figure 5 is a side view of the swing aid;

Figure 6 is a top view of the golf swing aid with

the actuator adjuster positioned to accommodate the most amount of movement prior to actuation;

5 Figure 7 is a sectional view taken along lines A-A of Figure 6;

Figure 8 is a sectional view taken along line B-B of Figure 6;

10 Figure 9 is a sectional view through the center of the golf swing aid similar to Figure 7, however with the actuator in the opposite extreme position to accommodate less movement prior to actuation;

15 Figure 10 is a view similar to Figure 8 but with the actuator in the opposite extreme position;

Figure 11 is a perspective view of the sensing arrangement in a minimum position;

20

Figure 12 is a side view of the sensing arrangement in a minimum position;

25 Figure 13 is a perspective view of the sensing arrangement in a maximum position;

Figure 14 is a side view with the actuator in a maximum position;

30 Figure 15 shows the circuit board used in association with the large contact actuator;

Figure 16 is a circuit diagram showing various electrical components of the golf aid;

35

Figure 17 is a schematic view of a simplified golf

- 7 -

aid being worn by a user during the golf swing;

Figure 18 is a view of a golfer wearing the golf aid and causing the golf aid to be actuated by a lateral
5 slide movement of the hips;

Figure 19 shows a golfer wearing the golf aid and actuating the golf aid by a hip tilt during a golf swing;

10 Figure 20 is a partial schematic view showing the adjustability of the actuator relative to the hip joint; and

Figure 21 shows the additional adjustability
15 device which can be accomplished by loosening of the lower leg strap of the golf aid.

DETAILED DESCRIPTION ACCORDING TO THE PREFERRED EMBODIMENTS OF THE PRESENT INVENTION IN WHICH:

20

The golf swing aid 2 shown in Figures 1 through 6 has a foam outer body 4 in combination with an elongated plastic cowl 6. The device includes a mode control switch 8, a slide actuator 10, a sound generator
25 indicated as 12, upper belts ports 14 and lower belt ports 16. The swing aid is to be worn such that the waist engaging end 20 of the foam outer body 4 is adjacent the person's waist. The device includes a waist belt arrangement which engages the upper belt ports 14.
30 In the embodiment shown a first upper belt will be connected to one of the belt ports 14 and second upper belt will be connected to the opposite belt port. These belts preferably have a two piece fast release adjustable clip arrangement at the opposite end for allowing the
35 belts to be snugly placed about the user's waist. Similarly, the lower belt ports will each receive and

engage a belt with these belts being securable about a users leg.

The size of the foam body tapers towards the lower leg engaging end 22. This defines a holster like configuration and the foam body has a concave lower surface generally indicated as 30. Within the concave underside of the foam body 4 is a further recess actuator cavity 32. This recess actuator cavity provides additional space for variable movement of the actuator within the recess actuator cavity.

A sensor 40 is secured in the plastic housing and is displaceable within the recess actuator cavity 32. The sensor includes an upper housing 44 and a lower housing 46. The upper housing includes a pivot cavity 45 which is inserted on and held by a retaining stud 63 of the upper cowl 60. Thus the upper housing 44 of the sensor 40 is secured to the upper cowl 60 but is pivotal about the pivot cavity 45. The lower housing 46 of the sensor 40 is displaceable relative to the upper housing. Projections 47 on the upper housing 44 cooperate with the slide slots 49 of the lower housing. Movement of the slide actuator 10 of the upper housing causes rotation of the upper housing about the pivot cavity 45. A series of projections on the housing adjacent the actuator 10 serve to maintain a set position of the actuator.

Movement of the actuator 10 changes the position of the projections 47 in the slots 49 and causes a displacement of the lower housing 46 either towards or away from the upper housing. This movement is clearly shown in Figures 11, 12, 13 and 14.

Figure 11 shows the sensor with the two housings in the most compressed or telescoped state. The actuator 10 is at the left end of the slot as shown in Figure 6. The

upper housing 44 is essentially fully received within the lower housing 46. The lower housing 46 is received within the lower cowl 62 and is held against rotate. Therefore movement of the actuator 10 causes displacement
5 of the lower housing and the actuator within the recessed actuator cavity 32.

Figures 13 and 14 show the sensor 40 in the opposite extreme position. As can be seen the upper
10 housing 44 and the lower housing 46 have been displaced due to the movement of the actuator 10 to the opposite end of a slot. The position of the sensor 40 as shown in Figures 13 and 14 would correspond with the sectional views of Figures 9 and 10.

15

Figure 6 shows the actuator 10 in the extreme left hand position, and as such the sensor will be in its most retracted position corresponding to Figures 11 and 12. The sectional view of Figure 7 shows the sensor 40 fully
20 retracted within the recessed cavity 32.

The outer foam body 4 serves to engage or contact the user and the cavity 32 is generally offset from the user by an outer flange area of the foam body about and
25 offset from the cavity 32. The sensor 40 is moveable within the recess cavity 32 by the user through the slide actuator 10. When the device is worn slightly behind the hip of the user, it is sensitive to improper movement of the hip and femur and the improper movement of the hip
30 and femur during the golf swing. A golf swing using improper hip movement will cause the femur to press on the sensor 40 causing activation thereof. It has been found that different golfers have different body types and furthermore individual golfers will accept or prefer
35 different amounts of movement of the hips. With this arrangement, the user can place the device on his rear

- 10 -

hip to locate the actuator slightly behind the hip. The belts top and bottom are wrapped about the user and thus hold the golf aid in the desired position. In addition, the slide actuator 10 can be positioned for the particular swing. For example, the golfer is practicing his swing for his driver the acceptable threshold before actuation of the device may be considerably larger relative to the amount of movement that will be tolerated for a different club such as a 5-iron or a wedge. Thus the golf aid can be adjusted by the user for a desired tolerance with respect to the degree of movement.

The sectional view of Figures 7 and 8 clearly show the sensor received within the recesses cavity 32. This position provides the largest tolerance with respect to undesired hip movement that is possible by adjusting of the sensor 40. As will be described in Figures 20 and 21, some additional tolerance can be provided by loosening of the straps particularly the straps associated with the lower leg.

The sectional views of Figures 9 and 10 show the sensor 40 in the opposite extreme position. As shown, the sensor has now moved into the recessed cavity 32 and is generally at or extending slightly out of the cavity. Thus the tolerance on the amount of movement of the hip has been significantly reduced. As previously described different body types can in affect the operation of the golf aid. In particular, for some different body shapes it may be necessary to increase the sensitivity of the unit beyond the sensitivity adjustment possible through movement of the slide actuator. Basically it is desired to have a golf aid where the user can adjust the golf aid for his own particulars as well as adjusting for different types of swings. It is possible to provide additional disks which are adhesively secured to the

- 11 -

sensor 40 to increase the thickness of the sensor. For some golfers, this may be necessary to provide them with a range of tolerance which can be adjusted by means of the actuator 10. The golf aid has been designed for the most common body types with a slight preference to body types where the tolerance range is basically from the front of the recess cavity 32 to the rear of the recess cavity 32. For some golfers, this range of motion can be shifted towards the body merely by the securing of the disks to the sensor 40.

The foam outer body provides a flexible, resilient, concave member for contacting the user. The elongated plastic cowl 6 is spaced off the user and acts as a lever or structural reference for the sensor 40. It has been found that this golf aid is very comfortable to wear for extended periods of time. The golf aid is also settable by means of mode switch 8 to produce different types of user perceptible signals. The device can produce a vibrating signal or it can produce an audible signal. The device also includes a light signal which is visible through the translucent mode actuator 8. It has been found that the golf aid is useful with an instructor or by the golfer on his own. The instructor can switch the golf aid to the light mode which is not visible to the user during the golf swing. Thus the instructor can have the student take a number of golf swings and the golf swings are not interrupted by the actuation of the device. However, the instructor has immediate feedback that a certain amount of movement has been exceeded. Preferably the light stays on for a number of seconds after being actuated whereby the user if on his own can also check the device to determine whether that particular swing was entirely within the set movement tolerance.

- 12 -

A further feature of the golf aid is that the actuator provides immediate feedback if desired when the user exceeds the tolerance. For example, when the golf aid is placed in the vibratory mode, as soon as the tolerance is exceeded a signal is produced which is sensed by the user. Therefore the user will have feedback throughout his golf swing. For example, if the tolerance is exceeded during the back swing the signal will be produced during the back swing. Whereas if the tolerance has been exceeded during the striking of the ball or the final hip rotation the signal is produced at that time. Therefore, whenever there is movement which exceeds the tolerance a signal is produced.

The sensor 40 includes a large circular actuator having a diameter in excess of 2 inches. This larger area is of benefit in allowing more general positioning of the golf aid relative to the hip joint and femur. Basically, any movement of the hip joint or femur which causes this disk to be displaced toward the golf aid will result in actuation of the sensor. Figure 15 shows the circuit board 80 having a large actuation area 82. Basically, the circular actuator merely contacts a small region on area 82 and causes a connection of the open circuit lines on the board. The circular actuator is held off the actuation area by a silicone cover which acts like a spring, providing a bias for maintaining the actuator in an off position. This cover is inwardly deformable to allow sensing of the hip movement. The large size of the actuator makes the exact placement of the golf aid less precise. Furthermore, it provides more tolerance for change in the size and body types of the golfer.

Figure 16 shows a general circuit diagram for the device. The mode switch 8 can be repeatedly actuated to switch from light mode, to vibratory mode, to audible

- 13 -

mode or various combinations thereof. The input information from the mode switch is fed to the circuit board 100. The circuit board then appropriately controls the actuation of the LED 102, the motor vibrator 104 or the audible buzzer 106. This circuit is powered by the battery 108. The momentary switch 110 is designed to deactivate the device when it is accidentally actuated or continues to be actuated when not in use. For example, if one presses on the mode switch 8 the device transfers from a standby state to an active state. The momentary switch detects the fact that the sensor 40 is being held on. This could occur during transport of the device or during storage thereof and would serve to drain the battery. The momentary switch detects this condition and deactivates the device returning it to its standby stage. Thus with the circuit as shown in Figure 16 the electronics are effectively always on in a standby state. The device is transferred to the active state by actuation of the mode switch. If desired the circuit can be modified to include an on/off switch. Such an on/off switch can be associated with the battery to thereby isolate the battery from the circuit.

Figure 17 is a schematic view of a simplified version of the golf aid 300 secured to a golfer adjacent the hip joint. As can be seen, the device is preferably worn on the rear hip of the golfer and secured to his waist and leg by means of ban attachments 120 and 122. The schematic view shows an actuator 124 with a lever 126 extending between the two belt attachments. The actuator is spaced off the user when the user is in the neutral position of Figure 17.

The general concept of the device is shown in the schematics of Figures 18 and 19. In Figure 18, the golfer's swing of the golf swing has caused to the golfer

to move from the neutral position of Figure 17 to a position where the device is actuated. This movement is typical of a lateral hip slide which is one of the common incorrect movements of a golfer during a golf swing. In 5 Figure 19, a slightly different movement has caused the device to be actuated. In this case, the golfer's hip joint and femur have moved due to an improper hip tilt. This hip tilt, can be caused in a number of ways but is often associated with a dropped shoulder. With a proper 10 golf swing the hip joint should have limited movement. The golf aid allows for some movement of the hip joint while allowing actuation during excessive movement of the hip caused by incorrect golf technique. The adjustability of the tolerance distance is clearly shown 15 in Figure 20. In this case, the user merely adjusts the actuator to vary the distance of the sensor 40 from the hip joint. Figure 21 shows a further means of adjustment by loosening of the lower belt. The plastic housing is generally rigid and certainly rigid relative to the foam 20 body 4. By loosening of the lower belt additional separation of the sensor from the hip joint occurs. In most cases, the belts will be comfortably secured about the users leg and about his waist. Adjustment of the degree of tolerance on the sensor or the actuation point 25 is adjustable by means of slide actuator 10. If additional sensitivity or effective shifting of the actuating distance relative to the foam housing is required adhesive foam disks may be secured to the sensor 40. It would also be possible although it has not been 30 found necessary, to add pads to the peripheral edge of the foam body 4. This type of adjustment might be necessary for certain extreme body types.

The golf aid as described herein, can be used at 35 the practice range and can also be used during the actual game of golf. At the practice range, the user will

- 15 -

continue to wear the device with both the waist and the leg straps secured. The device can be adjusted for the swing associated with different golf clubs and the mode of the device can be selected by the user. To avoid
5 distracting other golfers the device can either be used in the light mode alone or the light and vibratory mode. Some golfers may find the audible noise distracting to themselves and distracting to others. The device can obviously use a combination of these signals.

10

During a golf game it may be desirable if one is walking the course to release the leg attachment between golf strikes. A golfer may only wish to use the device for the swing associated with this driver or practice
15 swings associated with his driver and at other times would release the leg strap. This allows for a wider range of body movement which occurs on the golf course such as crouching down during putting as one example.

20

It has been found that the golf aid is of great assistance to an individual golfer for self training and developing a consistent swing. The device provides biofeedback when the tolerance range is exceeded. This is accomplished by means of the non-flexing body in
25 combination with the recessed cavity which is moveable within. The device is generally comfortable to wear and tends to be form fitting. The outer periphery conforms to the anatomy of the user and allows natural movement necessary for the golf swing and the playing of golf. The
30 device positions the sensing cavity and the sensor at a critical point for measuring of movement of the hip joint relative to the sensor.

The device is also useful with deaf golfers when
35 using the vibratory mode.

- 16 -

The golf aid is useful for different body types, different golfing skill levels and for different swing training techniques necessary for different golf clubs. You can practice by yourself or with a professional and
5 continue to receive biofeedback with respect to the proper torquing of the body about the spine. The device provides biofeedback on the control pivoting end or rotation and gives feedback when the hip joint has exceeded a certain range of motion. This improper range
10 of motion is often associated with hip slide, shoulder drop, improper shoulder turn, improper straightening of the legs, improper body positioning sometimes referred to as reverse C and changing alignment through the swing. The device is easily adjustable by the user for his
15 proper golf stance by assuming his correct golf stance and then adjusting the slide actuator until the device is about to go off. The golfer can then back off the sensor several settings to provide a desired degree of tolerance.

20

Although various preferred embodiments of the present invention have been described in detail, it will be appreciated by those skilled in the art that variations may be made without departing from the spirit
25 of the invention or the scope of the appended claims.

**THE EMBODIMENTS OF THE INVENTION IN WHICH AN EXCLUSIVE
PROPERTY OR PRIVILEGE IS CLAIMED ARE DEFINED AS FOLLOWS:**

1. A golf swing aid to be worn by a user comprising
5 a first attachment arrangement for securing of the
aid about the waist of a user such that aid hangs
downwardly over the hip of the user,
a second attachment arrangement for securement to
the leg of the user.
10 a lever arrangement secured between said
attachments and including an electronic sensor
positionable adjacent a user's hip joint for sensing
undesirable movement of said hip joint, said sensor
producing a user perceptible signal when the undesired
15 movement of said hip joint exceeds a preset threshold.
2. A golf swing aid as claimed in claim 1 wherein
said preset threshold is adjustable.
- 20 3. A golf swing aid as claimed in claim 2 wherein
said user perceptible signal is selected from the group
of vibratory signal visual signal and audible signal.
4. A golf swing aid as claimed in claim 1 wherein
25 said user perceptible signal is selectable by the user.
5. A golf swing aid as claimed in claim 4 wherein
said user perceptible signal is an audible or visual
signal.
30
6. A golf swing aid as claimed in claim 1 including a
foam body secured to one side of said lever arrangement,
said foam body having an outer peripheral edge
surrounding a sensor receiving cavity, said sensor being
35 located in said cavity in a recessed manner.

7. A golf swing aid as claimed in claim 6 wherein said sensor includes a large circular actuator movable against a spring bias.
- 5 8. A golf swing aid as claimed in claim 7 wherein said lever arrangement is an elongate plastic housing containing said actuator, electrical circuit means for said actuator, a user perceptible signal generator and a battery.
- 10 9. A golf swing aid as claimed in claim 8 wherein said foam body is secured to one side of said plastic housing.
- 15 10. A golf swing aid as claimed in claim 9 wherein said foam body is molded onto said plastic housing.
11. A golf swing aid as claimed in claim 10 wherein said plastic housing includes a slide member for
20 adjusting the position of said actuator within said cavity.
12. A method of detecting excessive movement associated with the hip joint during a golf swing
25 comprising
placing an electrical sensing arrangement over the hip joint for actuation by the hip during such excessive movement,
securing the sensing arrangement to the user above
30 and below the hip, and
producing a user perceptible signal when excessive movement of the hip has been detected.
13. A method as claimed in claim 12 including the step
35 of adjusting said electrical sensing arrangement to provide a user set tolerance of the amount of excessive

- 19 -

movement of the hip that is permitted before producing said user perceptible signal.

14. A method as claimed in claim 13 including the step
5 of selecting the user perceptible signal from a plurality of user perceptible signals.

14. A method as claimed in claim 14 used to detect at
10 least excessive lateral slide of the hips during a golf swing.

15. A method as claimed in claim 13 used to detect
during a golf swing excessive lateral slide of the hips
or excessive angling of the hips or a combination of
15 these movements.

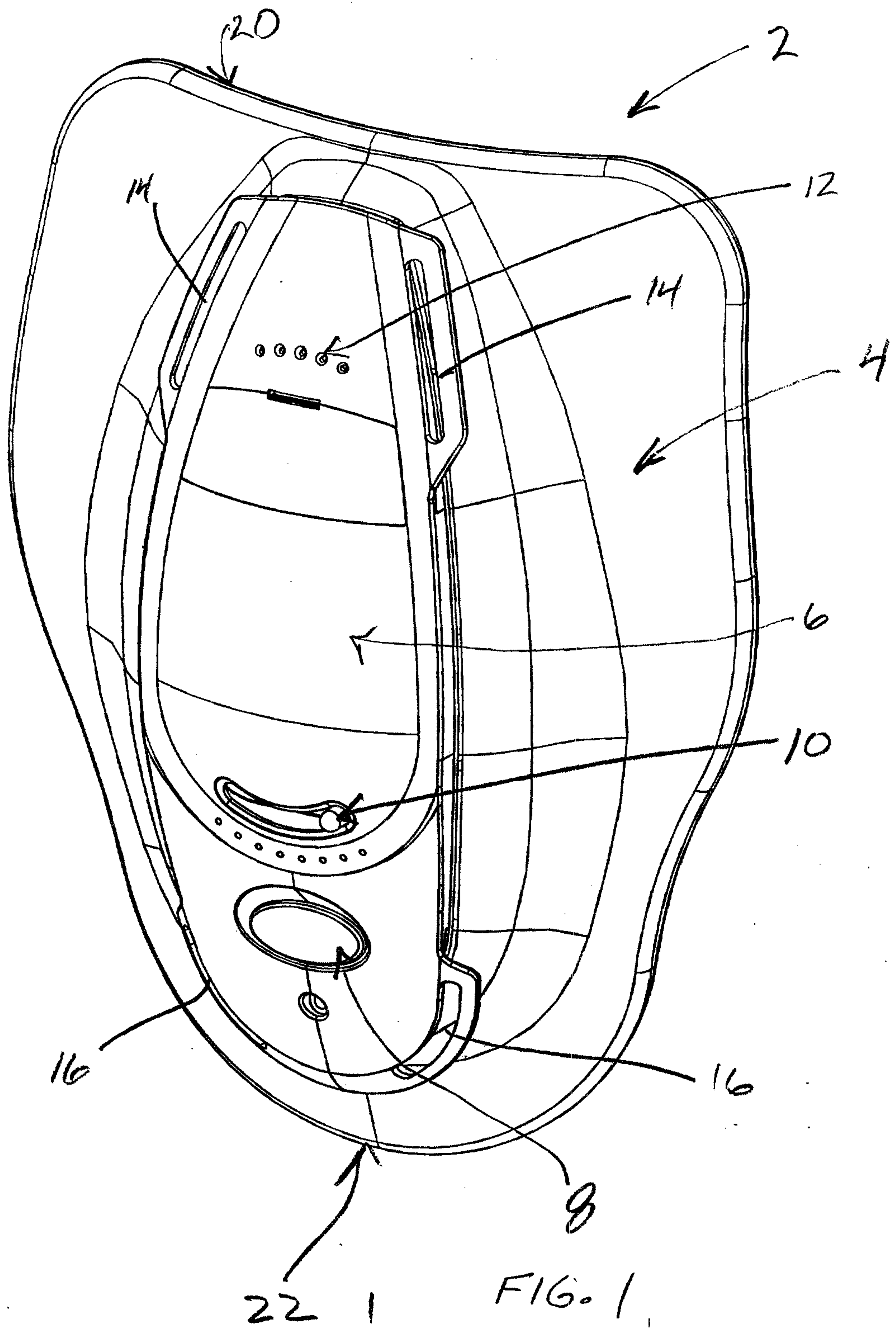

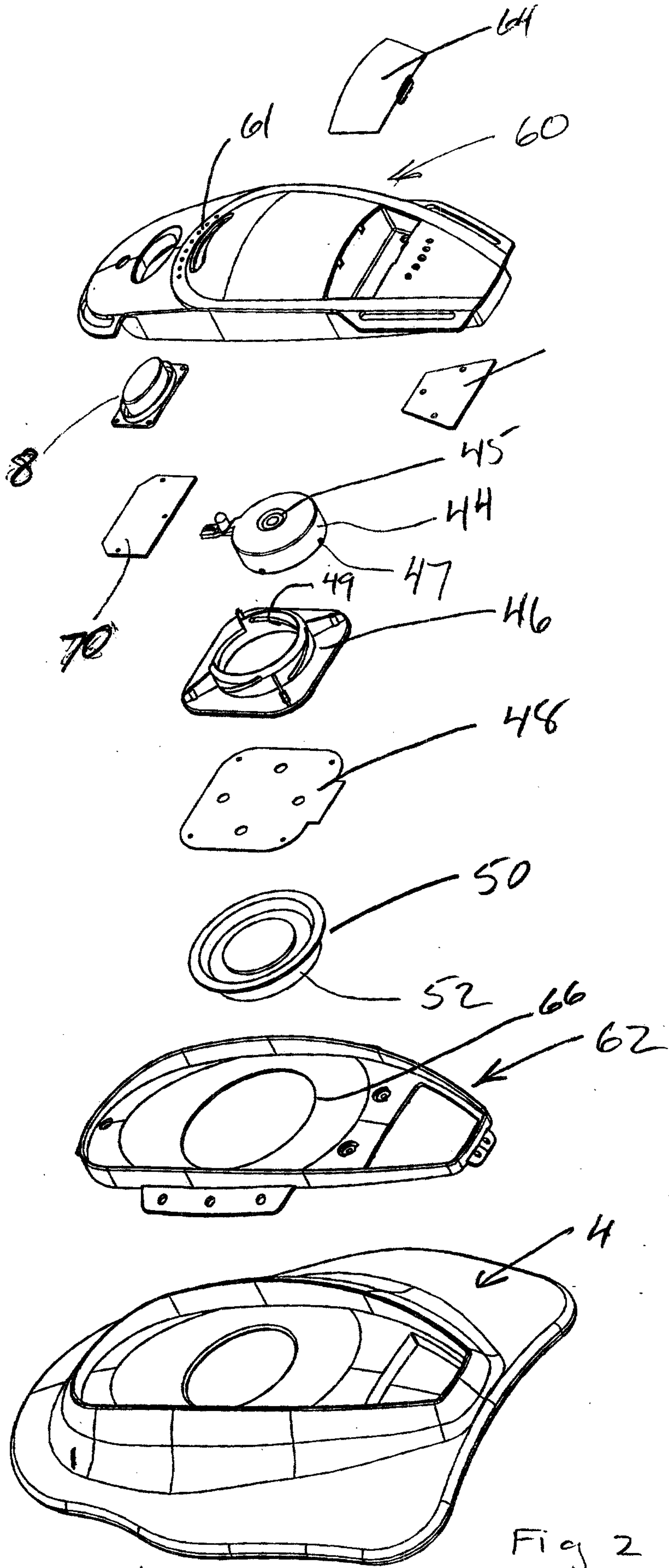

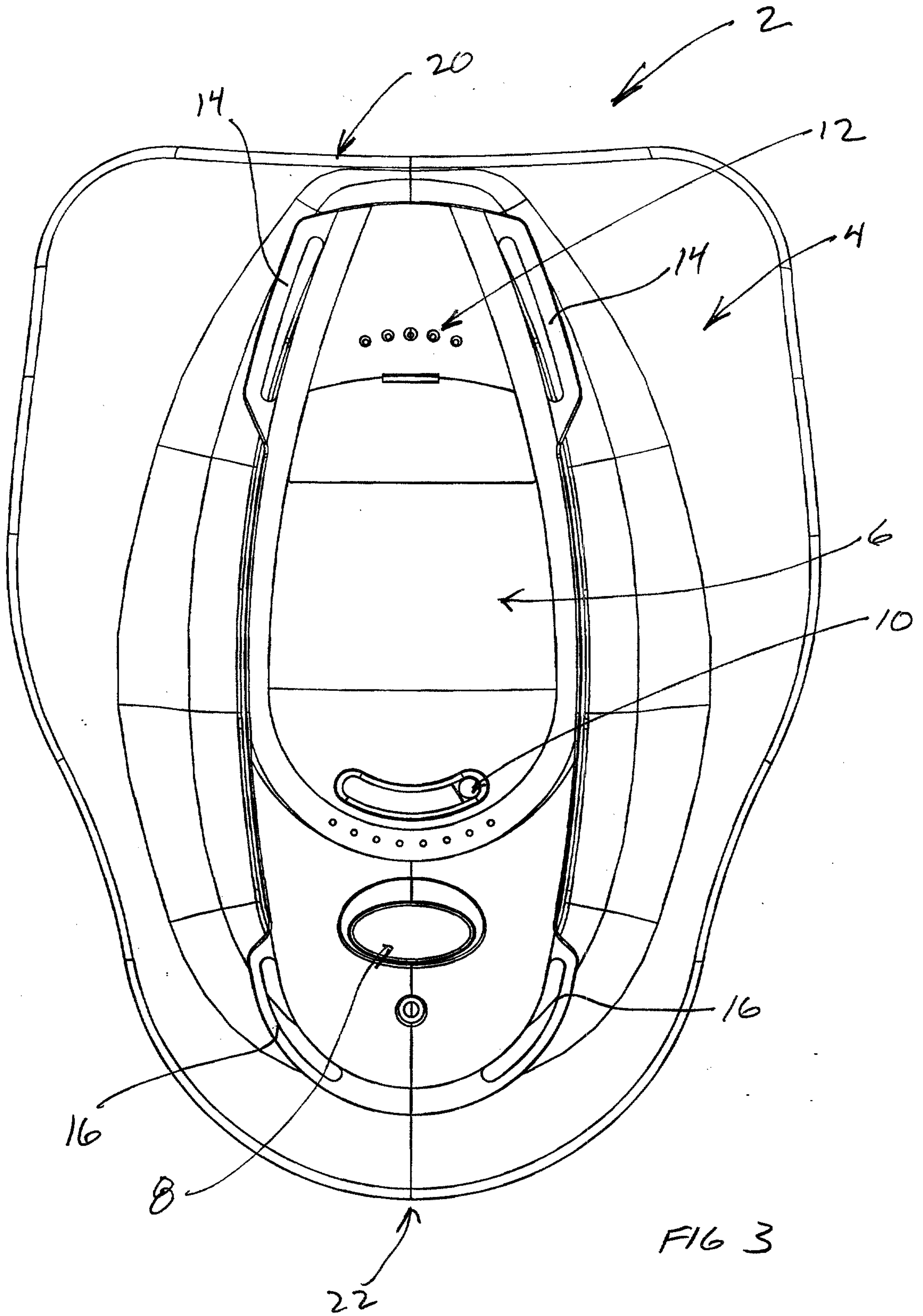

FIG 3

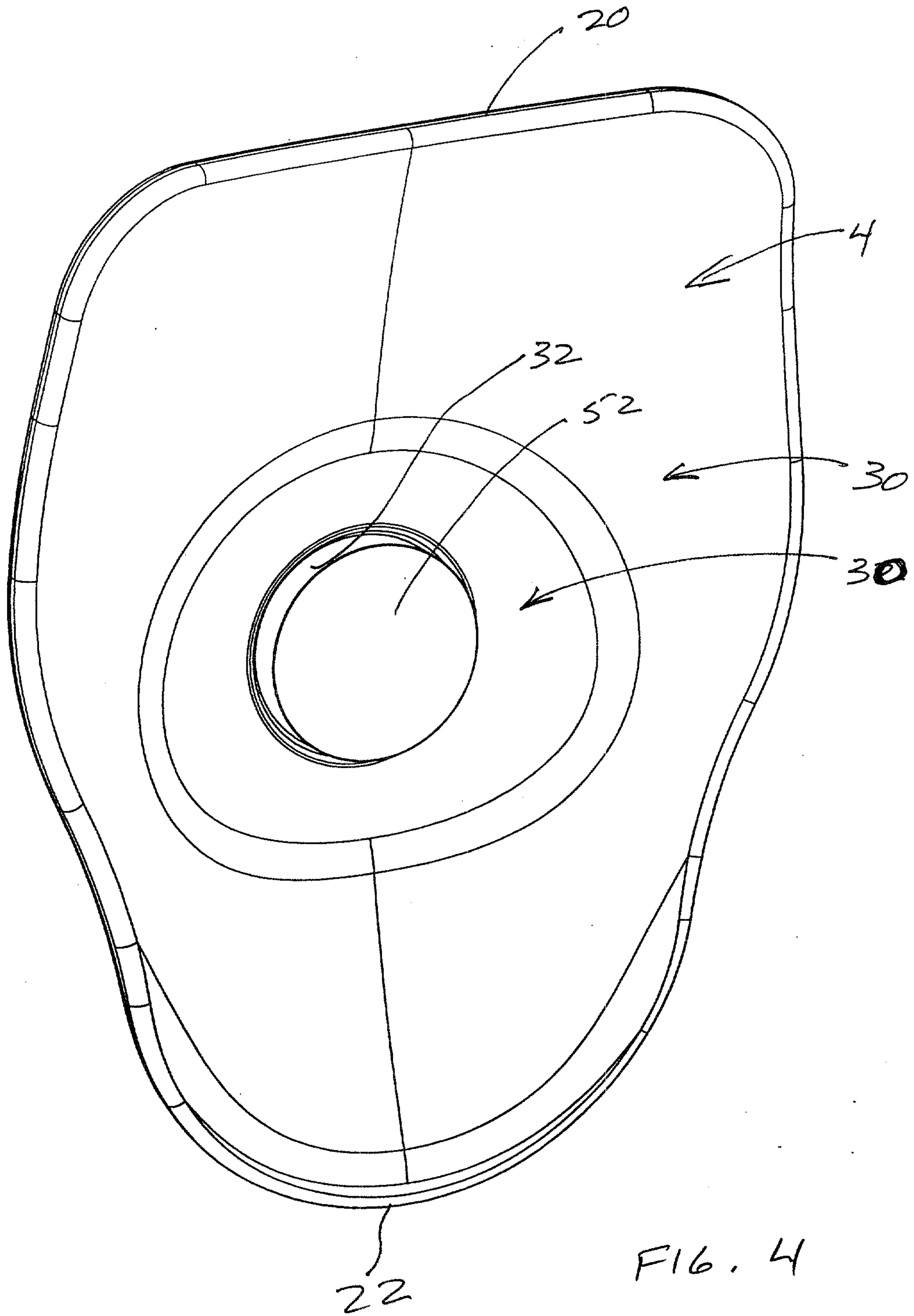

FIG. 4

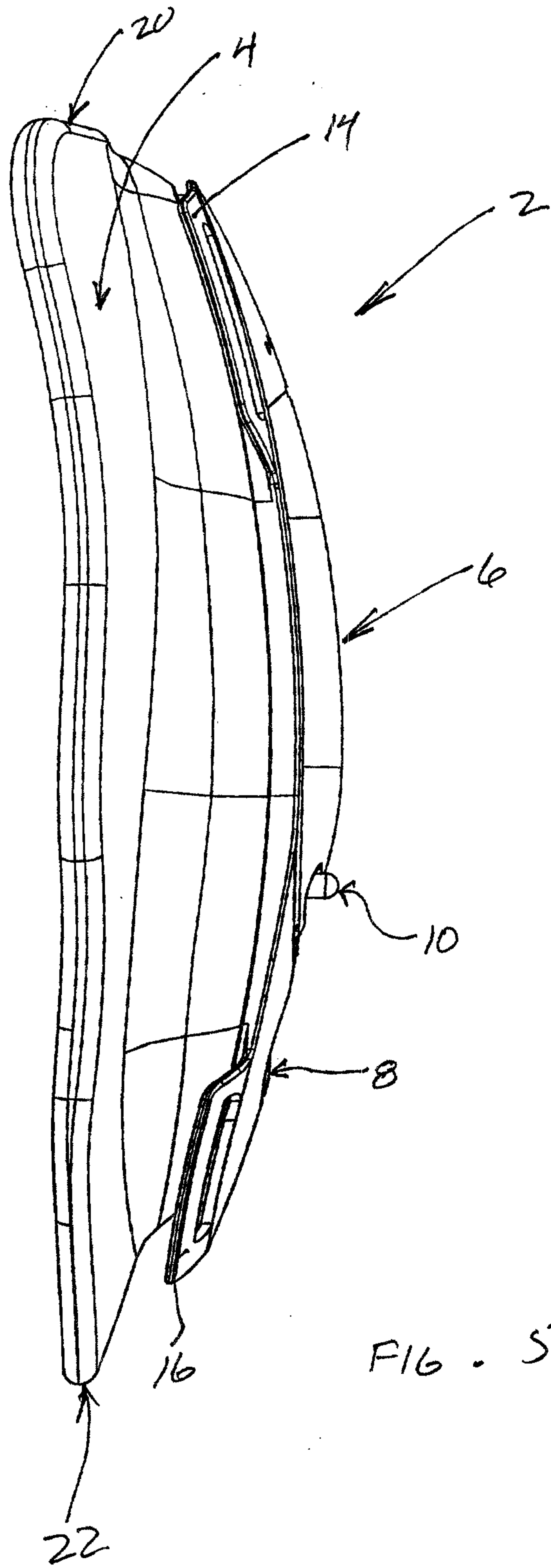

FIG. 5

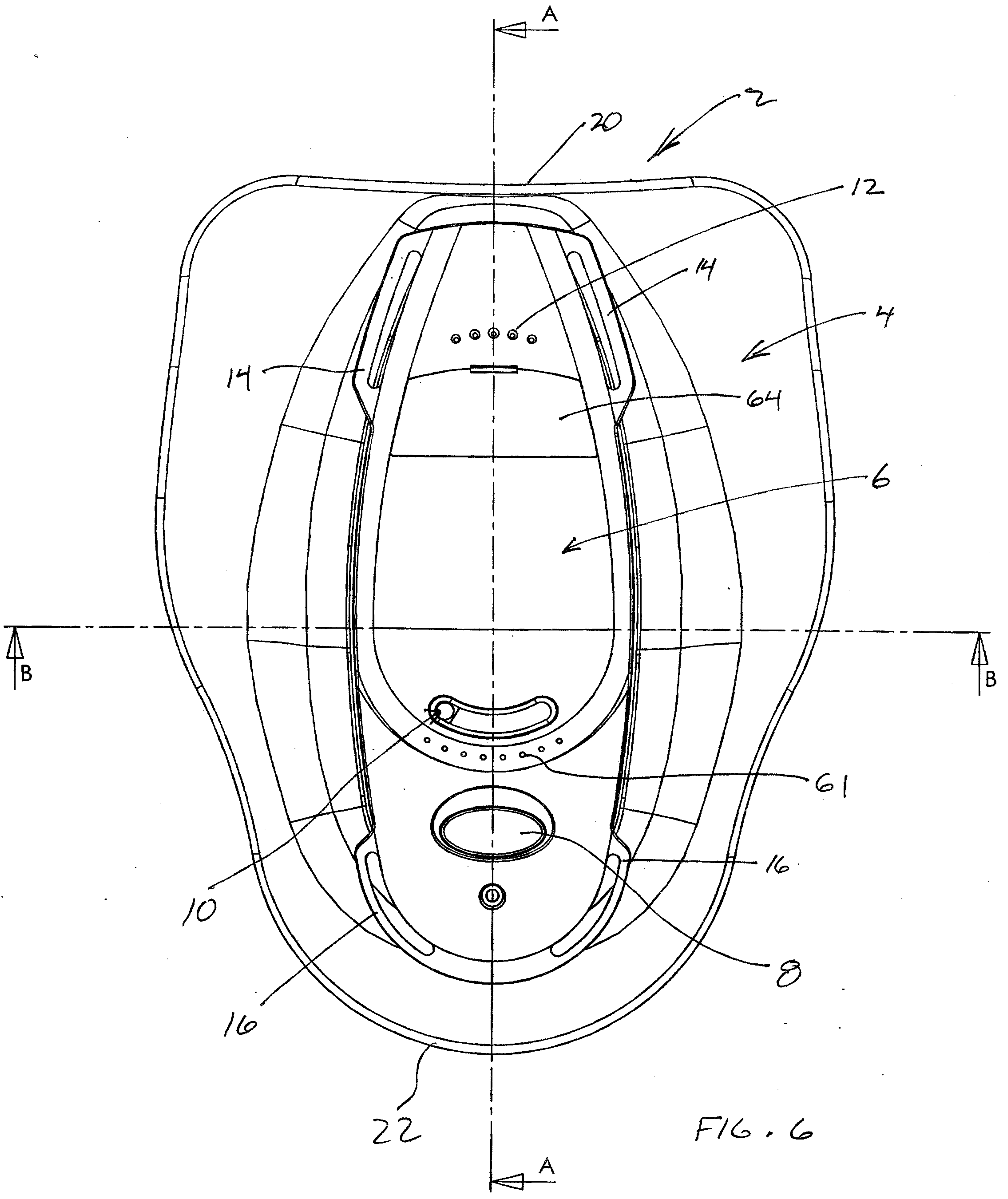

FIG. 6

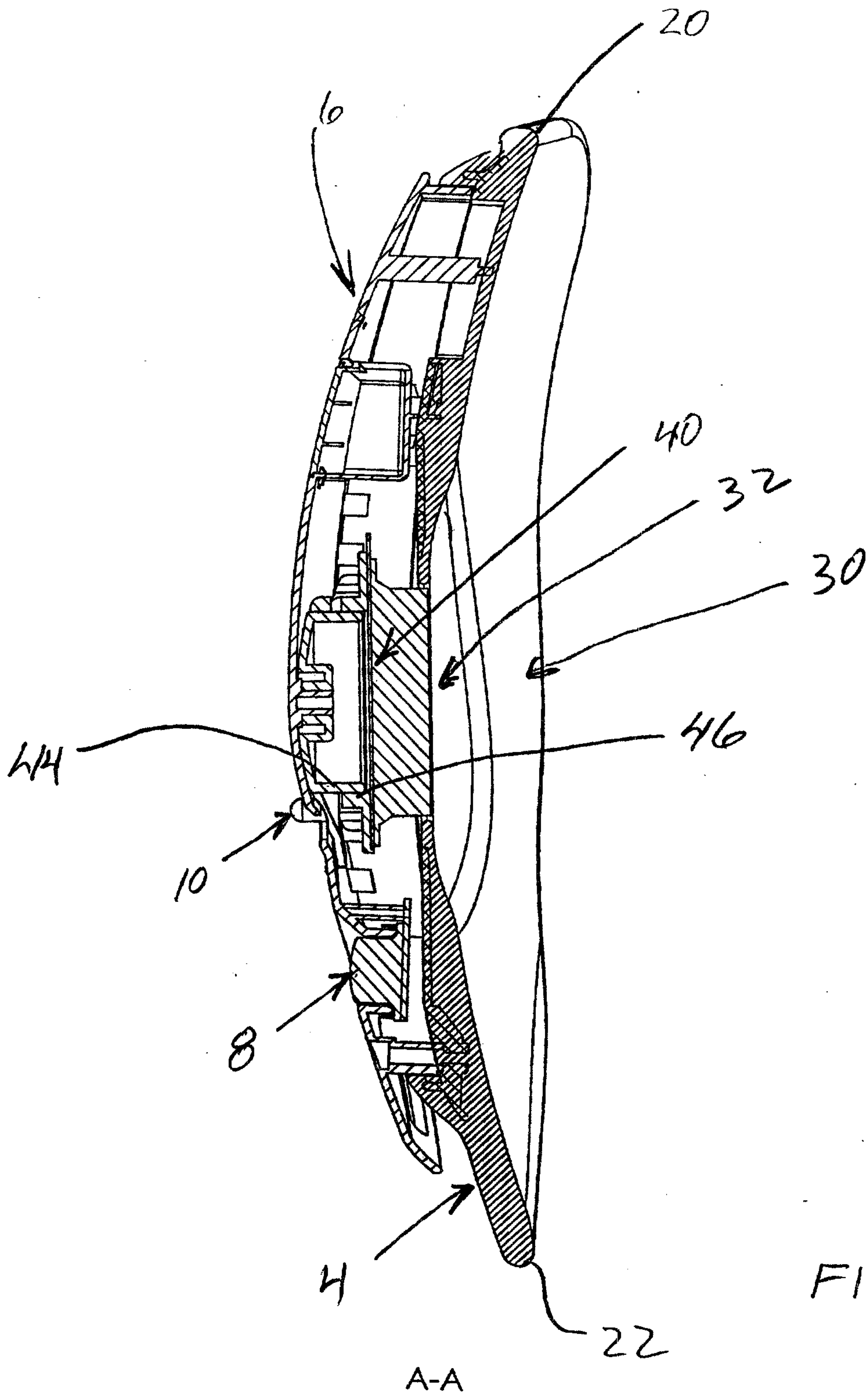

FIG. 7

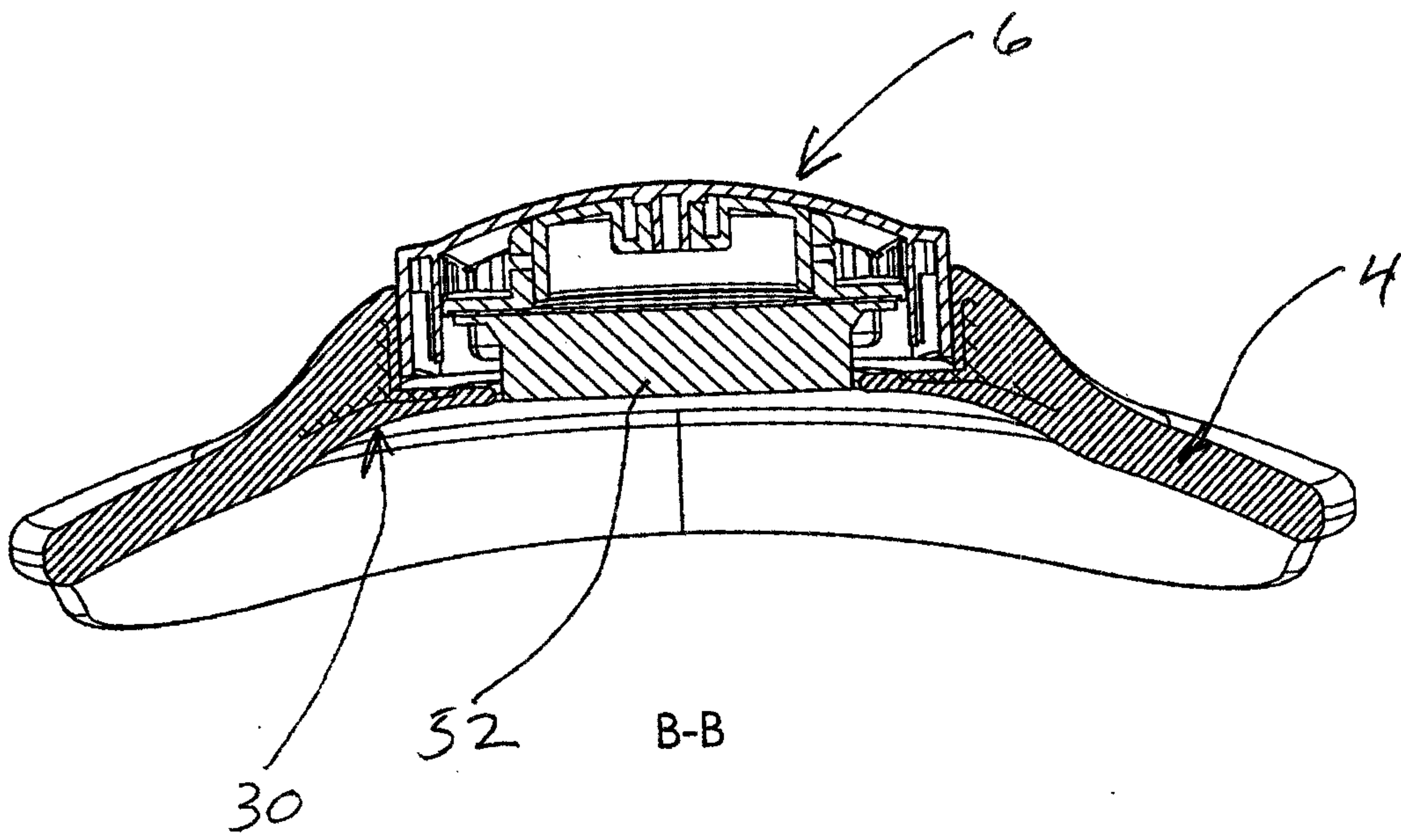

FIG. 8

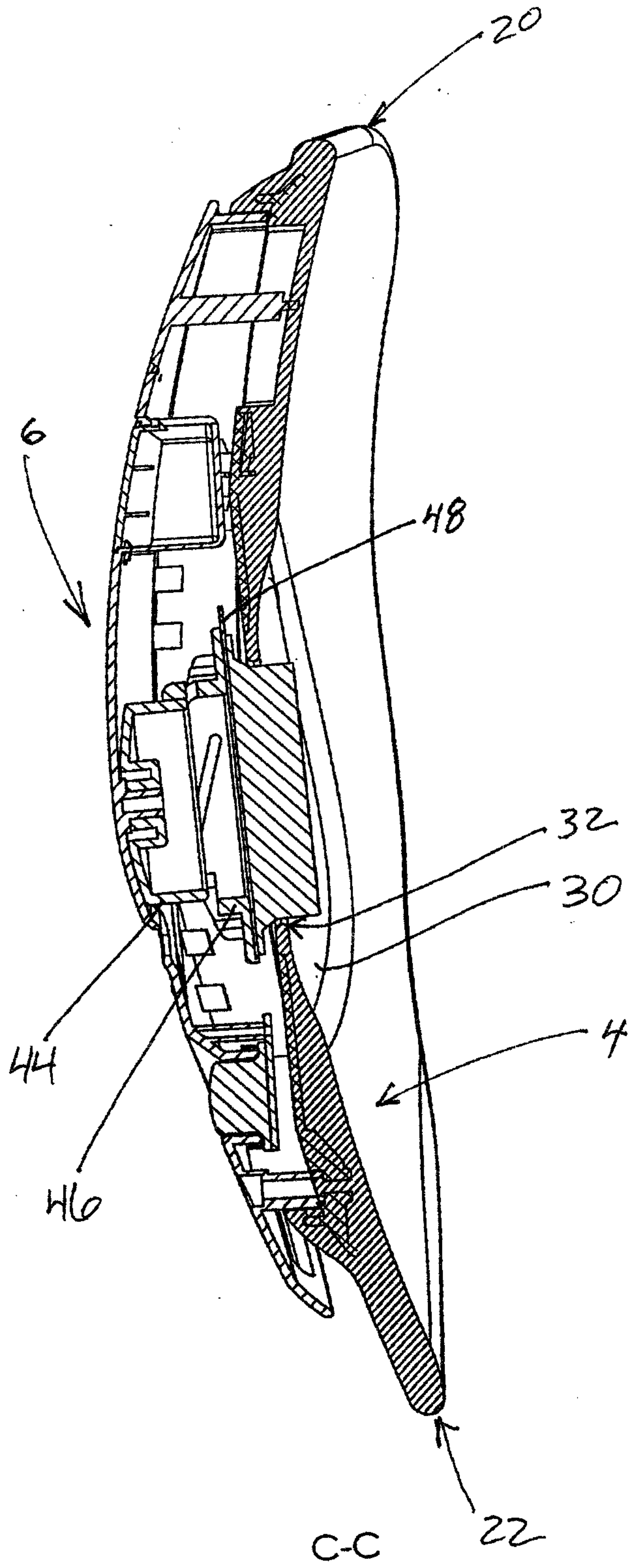
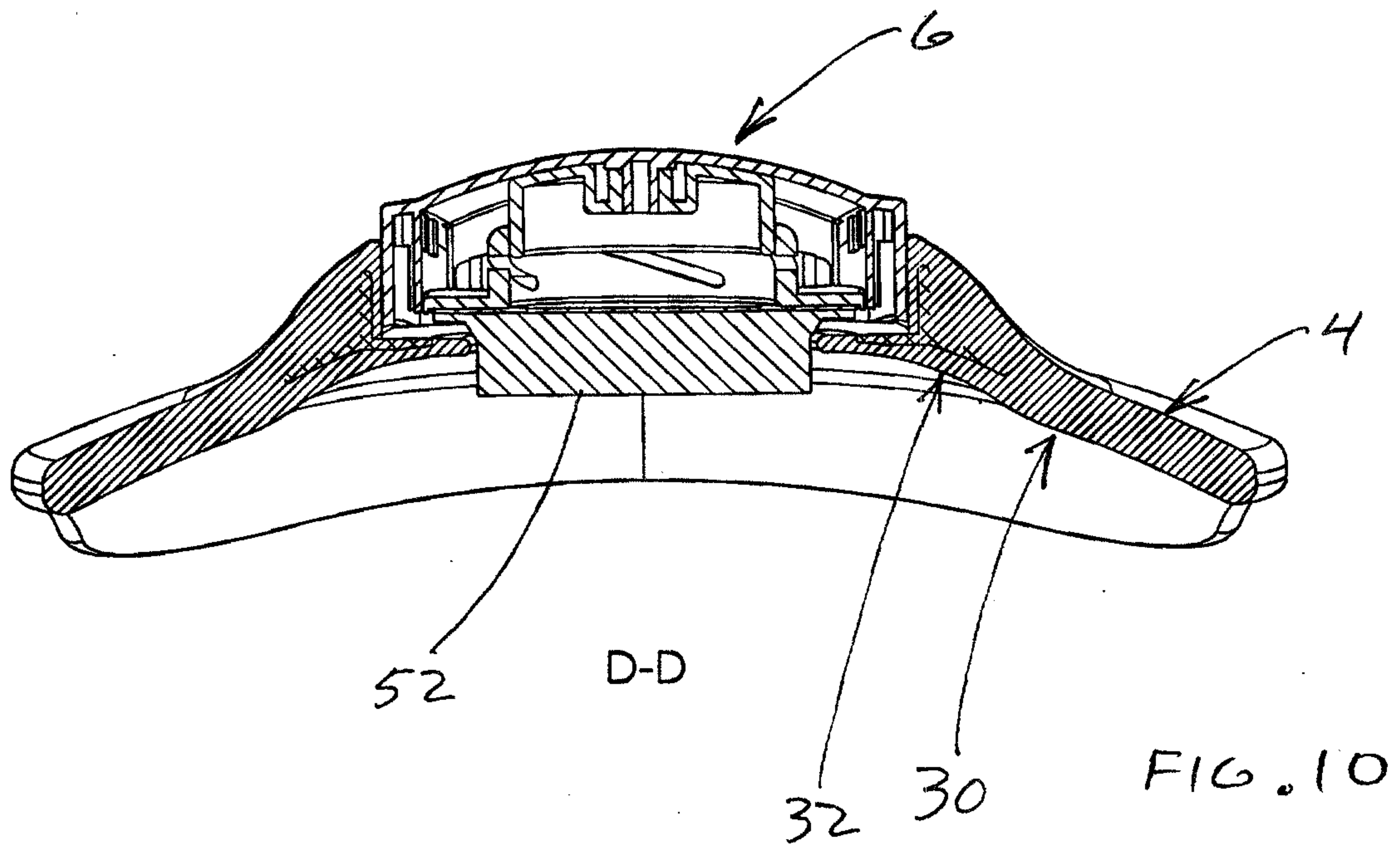

FIG. 9



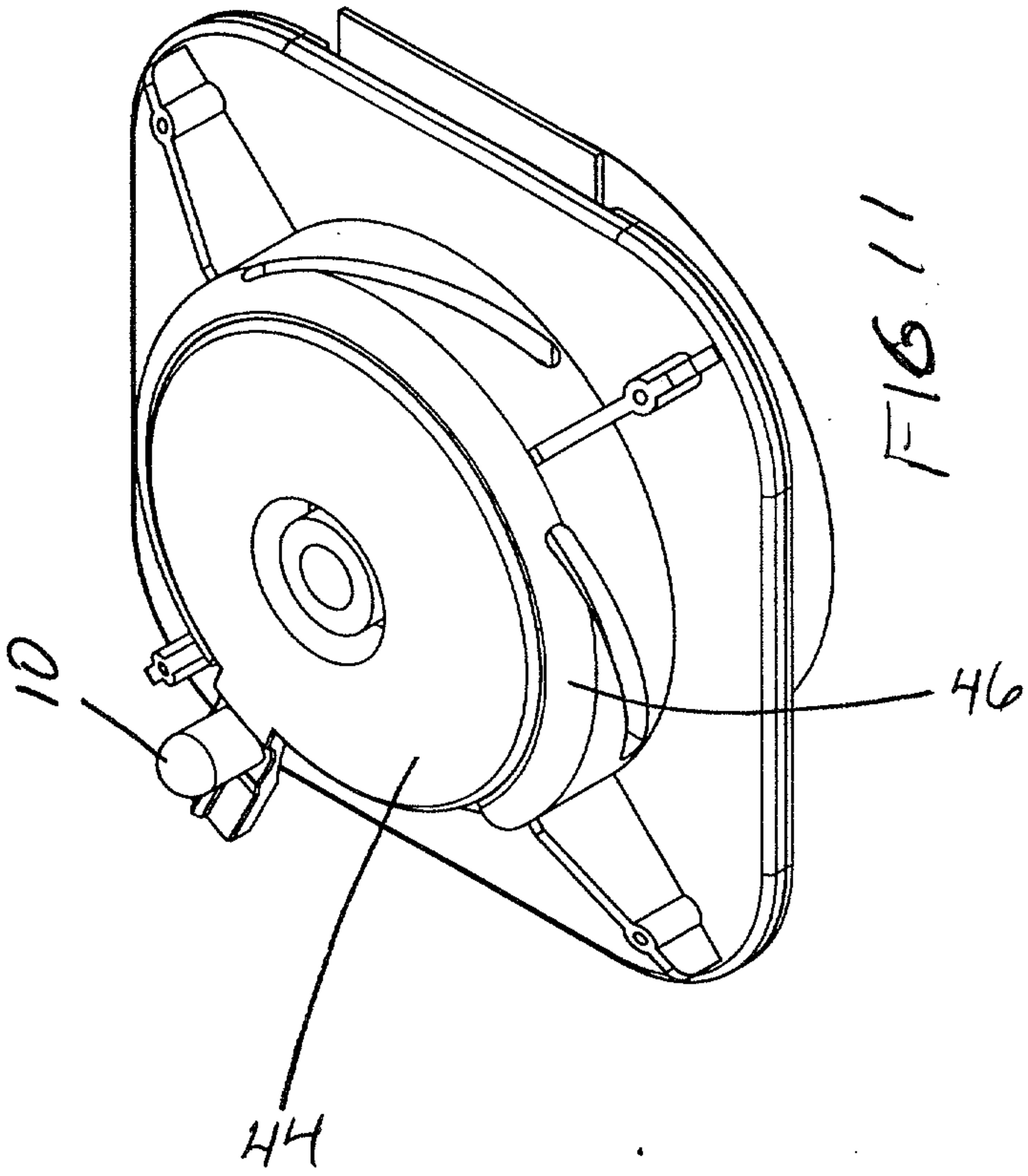

FIG. 11

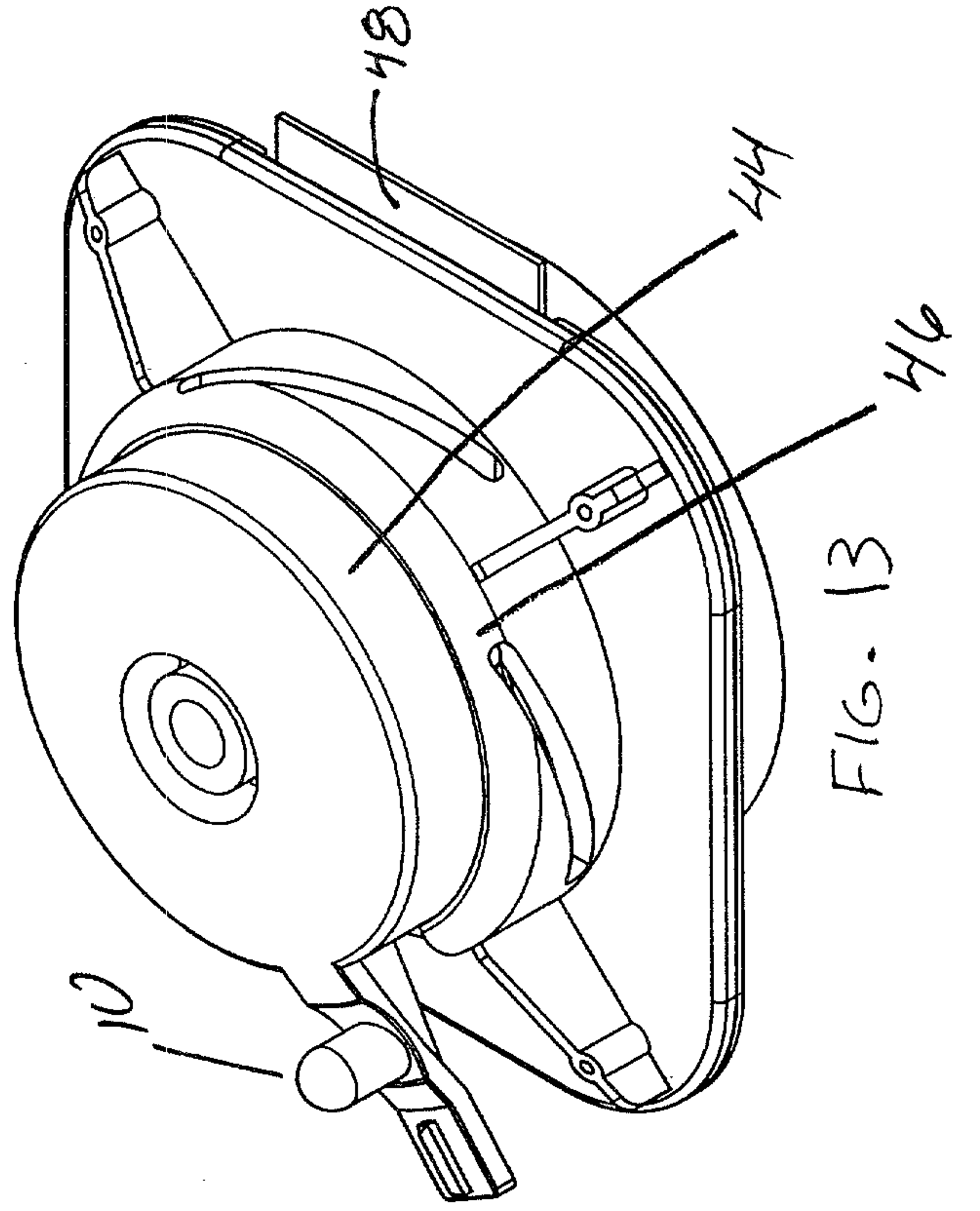

FIG. 13

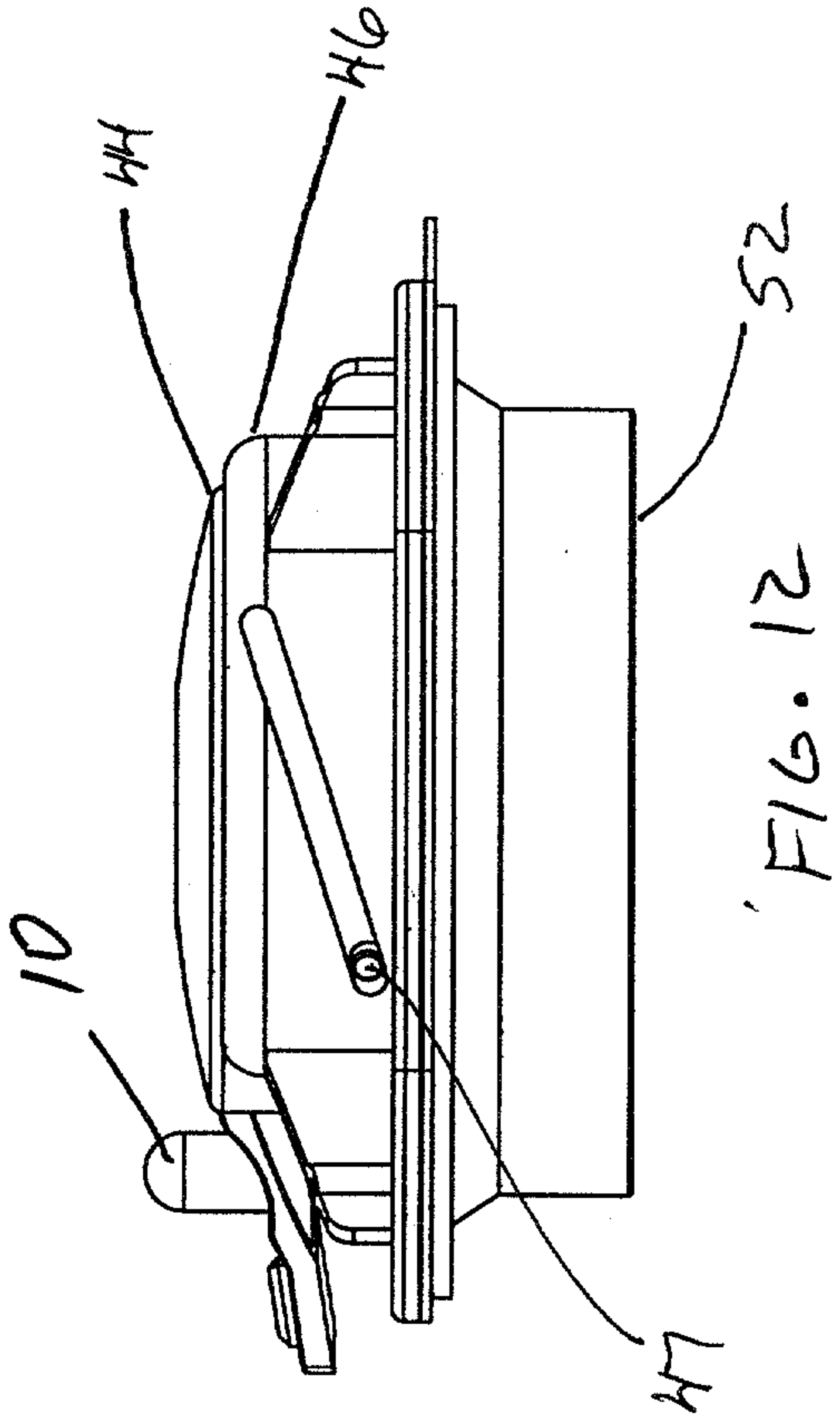

FIG. 12

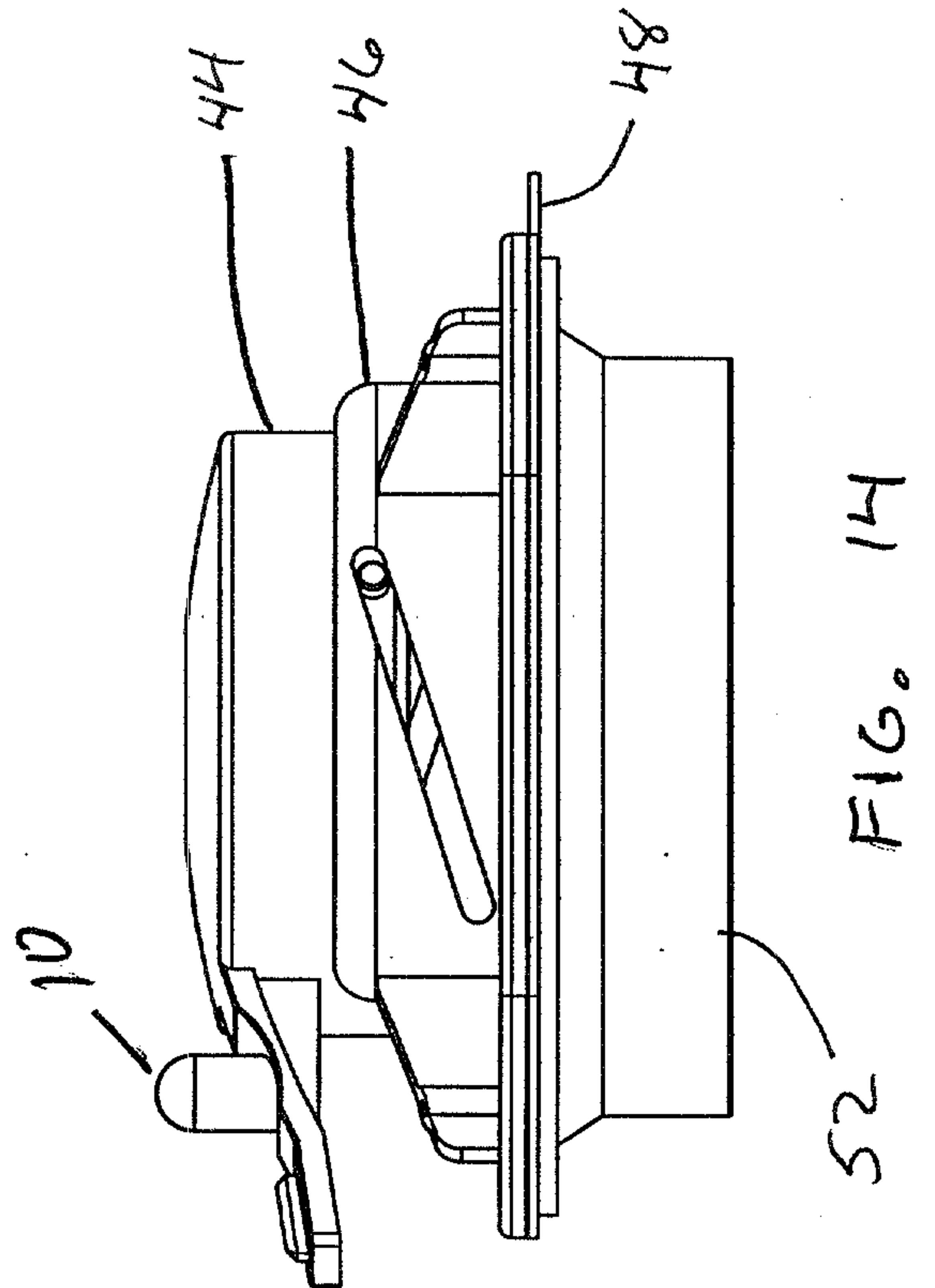
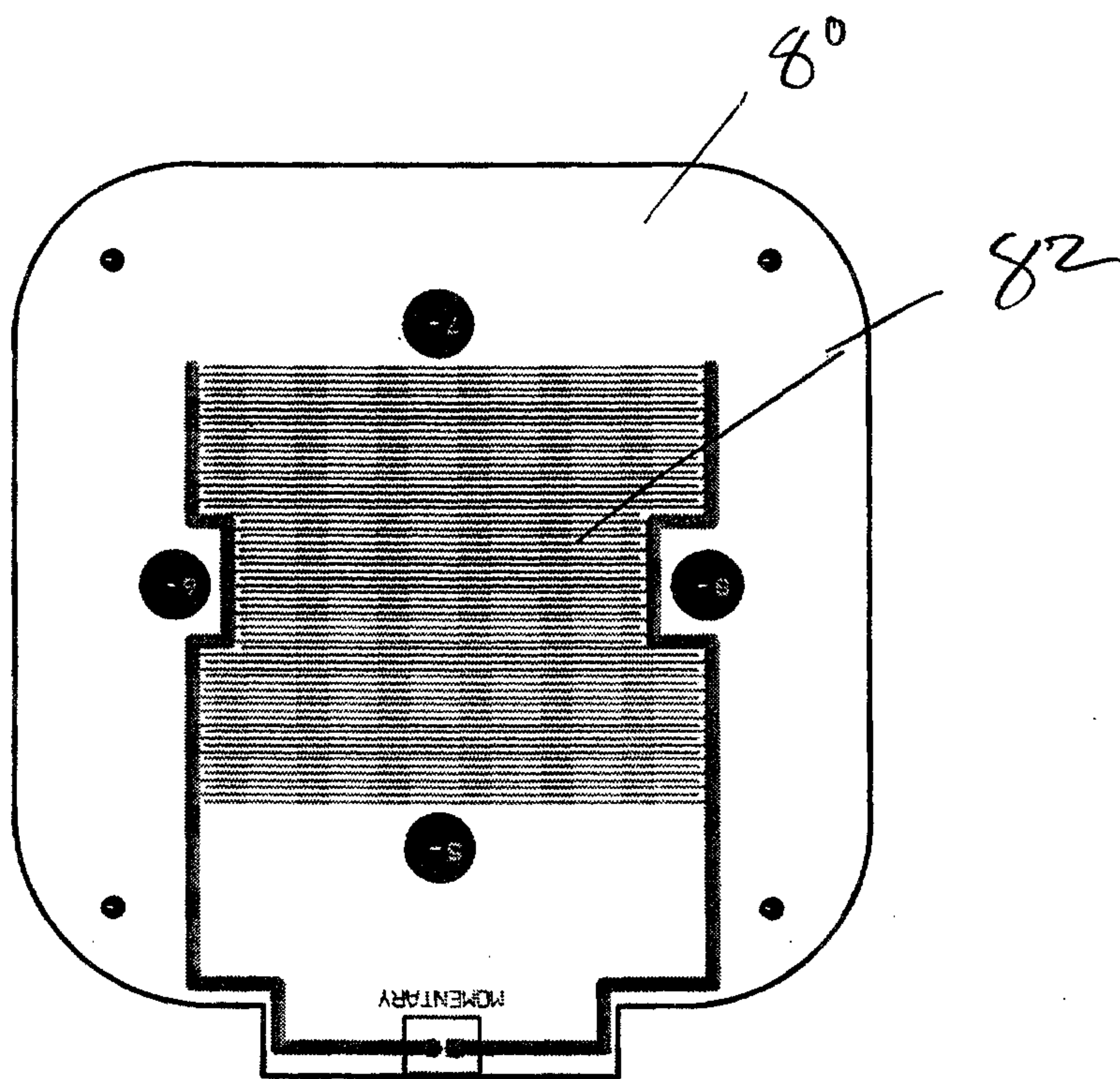

FIG. 14



F 16 15.

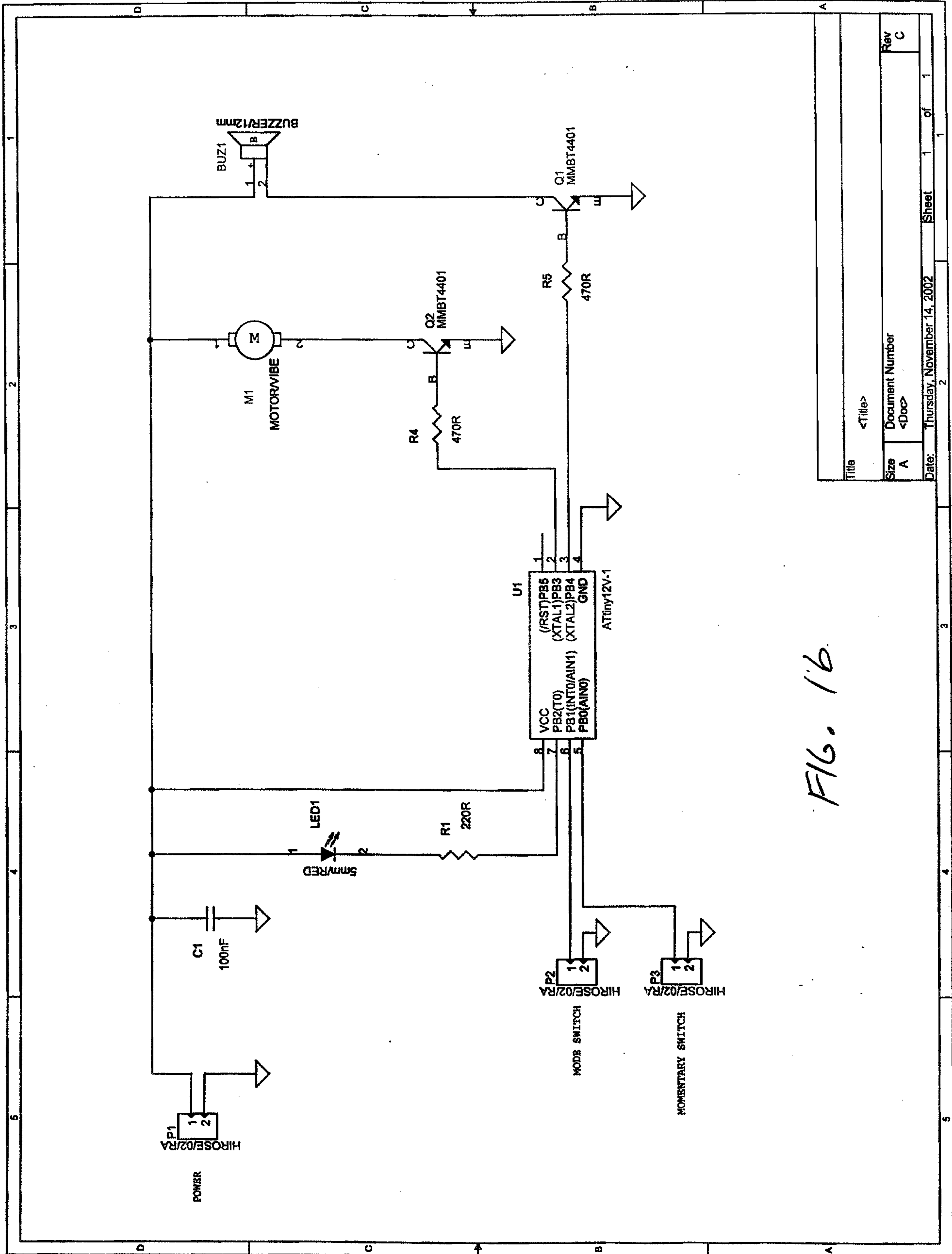

FIG. 16

Title		<Title>
Size	Document Number	Rev
A	<Doc>	C
Date:		Thursday, November 14, 2002
Sheet		1 of 1

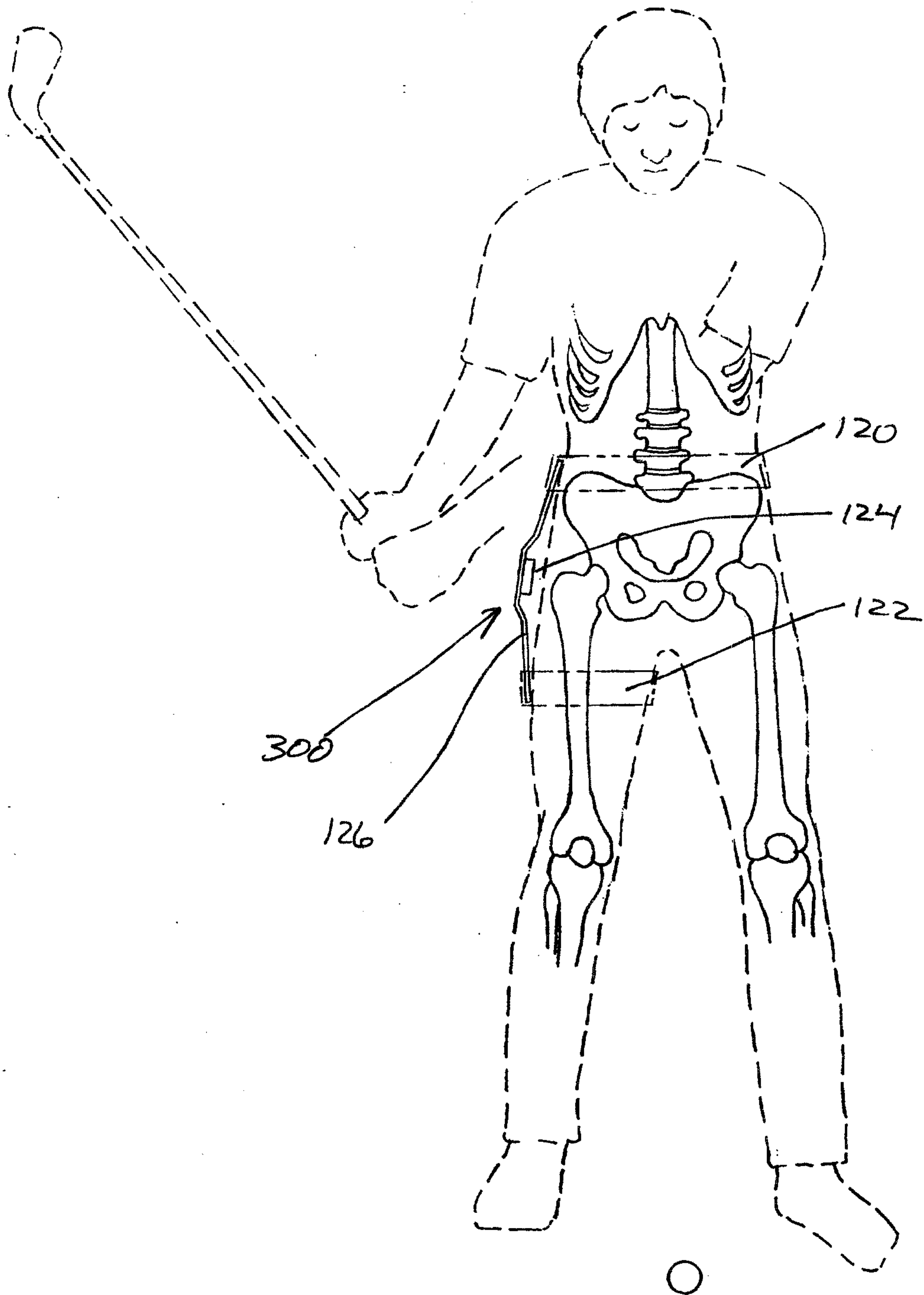

FIG 17

200

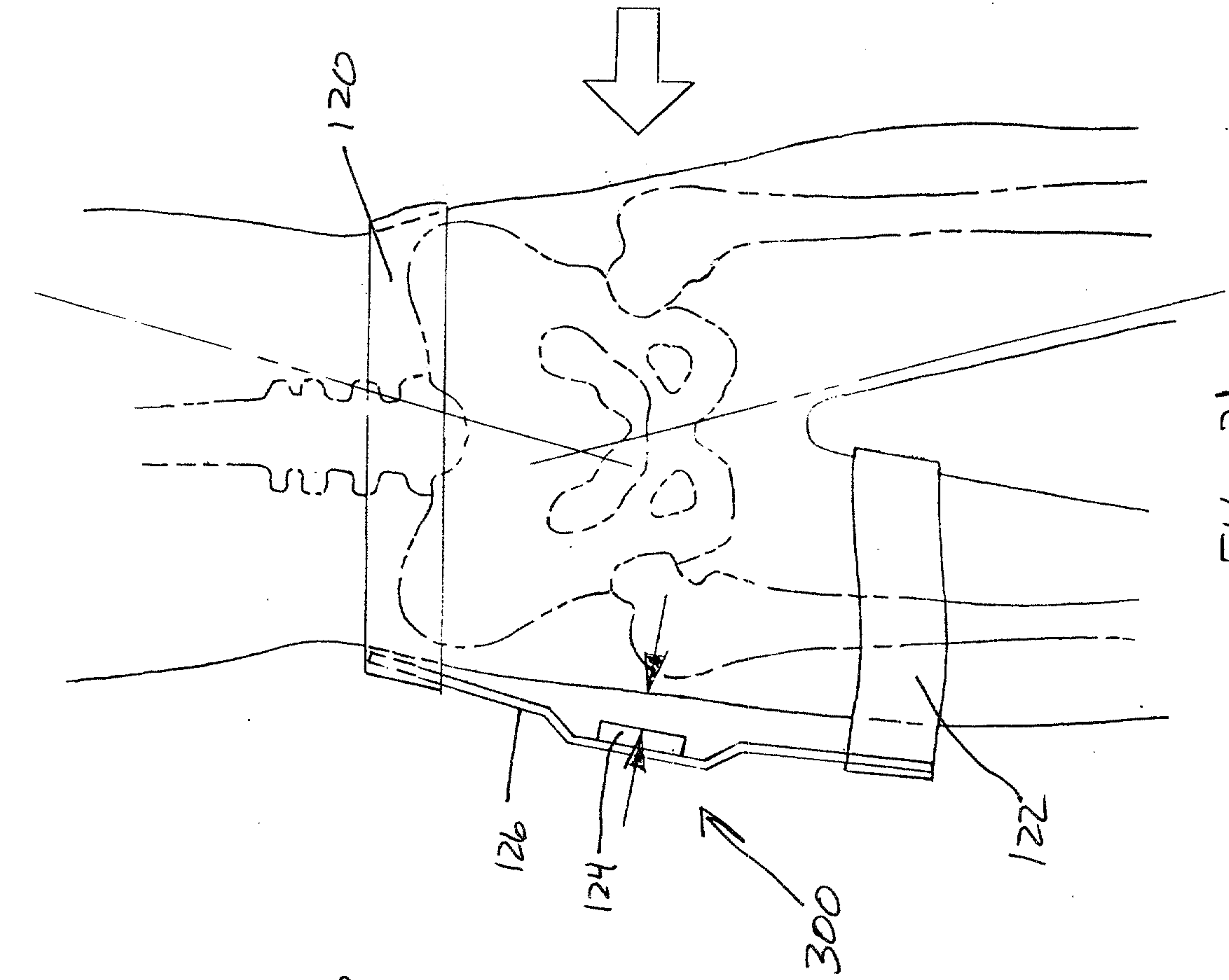

FIG. 20

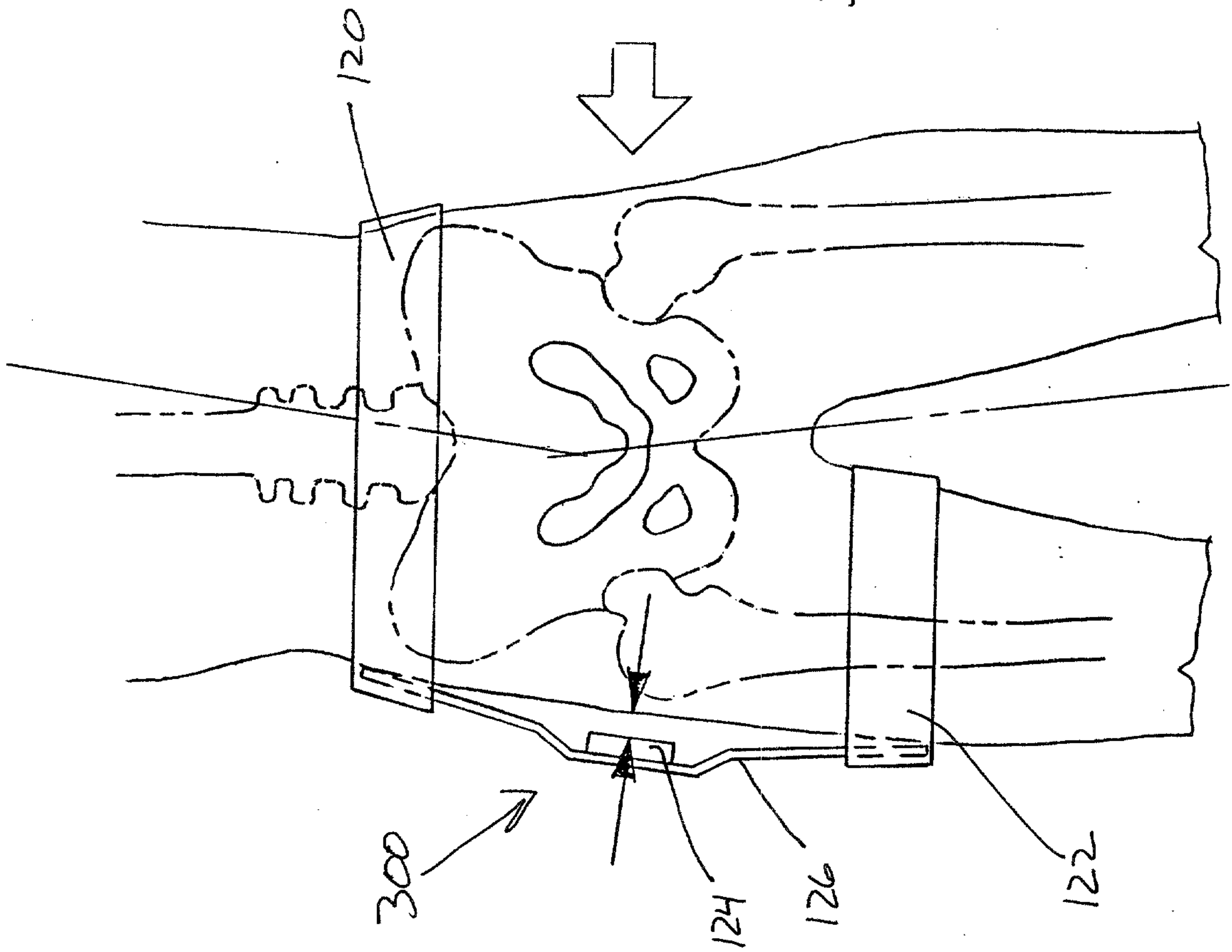

FIG. 21

