

(12) STANDARD PATENT
(19) AUSTRALIAN PATENT OFFICE

(11) Application No. **AU 2006244749 B2**

(54) Title
Improved refrigeration apparatus

(51) International Patent Classification(s)
F25D 21/14 (2006.01)

(21) Application No: **2006244749** (22) Date of Filing: **2006.05.08**

(87) WIPO No: **WO06/121347**

(30) Priority Data

(31) Number	(32) Date	(33) Country
539937	2005.05.10	NZ
542014	2005.08.25	NZ

(43) Publication Date: **2006.11.16**

(44) Accepted Journal Date: **2011.06.30**

(71) Applicant(s)
Skope Industries Limited

(72) Inventor(s)
Salt, Richard George Phillip

(74) Agent / Attorney
IP Gateway Patent and Trademark Attorneys, Suite 2, 18 Carol Avenue, Springwood, QLD, 4127

(56) Related Art
US 6070424
GB 1460450
US 2362729

IMPROVED REFRIGERATION APPARATUS

Technical Field

5 The present invention relates to an improved refrigeration apparatus. The apparatus of
the present invention has been designed with particular reference to refrigeration
apparatus which in use produces a significant amount of water when the apparatus is
defrosted, such as open deck refrigeration cabinets, which have a refrigerated air
curtain rather than doors over the front of the storage area. However, the present
10 invention also could be used in combination with other types of refrigerated cabinets.

Background of the Invention

The reference to any prior art in this specification is not and should not be taken as an
15 acknowledgement or any form of suggestion that the referenced prior art forms part of
the common general knowledge in Australia.

At present, a refrigeration apparatus disposes of the water produced when the
apparatus is defrosted in one of four ways:-

20

1. The tray which receives the water is electrically heated to evaporate the water.
This is effective, but increases the power requirement of the apparatus,
especially if relatively large volumes of water are involved.
- 25 2. The tray which receives the water also contains a multifolded cloth wick; the
water soaks through the cloth and this greatly increases the area from which the
water can evaporate. This design has the drawback of maintaining a large area
of damp, porous cloth in a warm dark environment:- the conditions are ideal for
fungal/bacterial growth and the equipment can be very difficult to keep clean.
- 30 3. The water is ducted into a drainage pipe. This is an excellent solution to the
problem, from the point of view of requiring no additional power and producing
no hygiene problems, but it means that the refrigeration apparatus is
permanently connected to a drain and thus cannot be relocated without re-
35 plumbing.

4. The tray which receives the water is heated by the hot gas from the compressor by way of tubing which runs from the compressor to the condenser coil, through the tray. However, this is only partially effective because in general there is insufficient air flow over the tray to effectively remove the water vapour.

Summary of the Invention

An advantage of the present invention is the provision of refrigeration apparatus which disposes of the water produced during defrosting efficiently and hygienically, with little or no additional power requirement, and without limiting the placement of the apparatus (i.e. the apparatus does not need to be plumbed-in).

According to a first aspect, the present invention provides a refrigeration apparatus which includes:

an evaporator, a compressor and a condenser, connected by pipework in known manner, a fan, and a tray arranged to collect water during the defrost cycle of the apparatus; wherein:

- a) the tray provides a base and a wall surrounding the base;
- b) at least the compressor, condenser, fan and tray are contained within a housing which is substantially closed except for air vents;
- c) at least part of the pipework between the compressor and the condenser is located within the tray;
- d) the condenser is located in the tray such that at least a major portion of the condenser lies below the upper edge of the wall of the tray;
- e) the fan, housing and tray are designed and arranged such that in use the fan moves air through the housing so that substantially all of the air is directed over the surface of the tray.

The condenser may be provided with cooling fins having a spacing not more than 60 fins/metre. The fan may be located at the front or at the rear of the housing, i.e. to blow air through the housing or to draw air through the housing. As used herein, the term "front of the housing" means that end of the housing which is upstream relative to the airflow through the housing. This is the end of the housing which normally would face

outwards in use, but this need not be the case. The term "rear of the housing" correspondingly means the end of the housing which is downstream relative to the airflow, i.e. through which the air leaves the housing.

5 As used herein, the term "fan" refers to a single fan or to two or more fans, as appropriate for the size of the apparatus and the particular application of the apparatus. The refrigeration apparatus may be built into a refrigeration cabinet in the usual way, but preferably is made as a removable cassette which can be withdrawn from the cabinet without dismantling the cabinet.

10

If the apparatus is made as a removable cassette, then the evaporator must be contained within the housing. If a removable cassette is not required, then the evaporator may be located apart from the remainder of the refrigeration apparatus, and the defrost water from the evaporator piped or ducted to the tray.

15

Brief Description of the Drawings

By way of example only, preferred embodiments of the present invention are described in detail with reference to the accompanying drawings in which:-

20 Fig. 1 is a diagrammatic longitudinal section through an open deck refrigeration cabinet incorporating a first embodiment of the present invention;

Fig. 2 is a view of the lower portion of Fig. 1 on a larger scale;

Fig. 3 is a diagrammatic longitudinal section through a second embodiment of the present invention;

25 Fig. 4 is a plan view of the second embodiment of the invention;

Fig. 5 is a diagrammatic longitudinal section through a third embodiment of the present invention;

Fig. 5a is plan view of the third embodiment, and

30 Fig. 6 is a diagrammatic longitudinal section through a fourth embodiment of the present invention.

Detailed Description of Preferred Embodiments

35 Referring to Figs. 1 and 2, an open deck refrigeration cabinet 2 comprises an insulated enclosure which provides a top 3, side walls 4, a rear wall 5 and a base 6, but which is

open over substantially all of the front surface 7. Shelves 8 for displaying products are mounted between the side walls 4. An air curtain for providing a curtain of refrigerated air down the open front 7 is of known type and has an air outlet 9 in the top 3 and a return air vent 10 in the base 6.

5

The insulated enclosure is mounted on a base 11 in which the refrigeration apparatus is mounted in the form of a removable cassette 12 which can be withdrawn from the base without dismantling the cabinet.

10 The refrigeration apparatus consists of a condenser 13, an evaporator 14 in an insulated enclosure 14a, and a compressor 15; a fan 16 is mounted directly behind the condenser 13, to draw ambient air through the condenser in use.

15 The condenser, evaporator and compressor are of known type and will not be described in detail. The refrigeration cycle is the usual one:- a refrigerant fluid is circulated between the condenser and the evaporator through tubing (not shown). The compressor 15 draws refrigerant fluid in gaseous form from the evaporator 14, compresses the gas and circulates the compressed gas to a condenser 13 where the gas is condensed by a combination of the increased pressure and the loss of heat. The liquid refrigerant is then circulated to the evaporator 14. In the evaporator 14, the pressure is reduced and the refrigerant fluid evaporates to a gas, absorbing heat from the surrounding air as it does so. The refrigerant gas is then drawn back into the compressor 15 and the cycle continues. The upper part of the cabinet is refrigerated by the air curtain formed by air circulated over the evaporator 14, in known manner.

25

Since the air circulated over the evaporator 14 is chilled, moisture in the air condenses out and freezes onto the outer surface of the evaporator and other chilled surfaces of the cabinet. During the defrost cycle this frost becomes water again and drains through the aperture 17 in the base of the insulating enclosure 14a into a tray 18 in the base of the cassette 12.

30

For refrigerators with closed doors, the quantity of water draining into the tray 18 is relatively small. However, with open deck refrigeration cabinets much more ambient air gets into the cabinet, and the quantity of water draining into the tray 18 can be relatively large:- for example, a 1200 millimetre wide cabinet typically has an air curtain

35

flow of about 55 litres per second and about a 0.9 litres per hour of water draining into the tray.

In the present invention, the water in the tray 18 is evaporated with a combination of
5 two mechanisms:- firstly, the pipe 19 used to circulate the comparatively warm refrigerant fluid from the compressor 15 to the condenser 13 is arranged to pass along the length of the tray 18, thus heating the water in the tray 18. Secondly, the top, base, and sides of the cassette 12 are closed, so that substantially all of the ambient air drawn through the condenser 13 by the fan 16 (indicated by double headed arrows)
10 must enter the housing through the front vents 20, pass over the surface of the water in the tray 18, and leave by the rear vents 20a, since the refrigerant fluid is condensed in the condenser, thus giving up its heat of evaporation, the air drawn through the condenser is heated. This combination of heating and rapid warm airflow over the surface of the tray is effective in evaporating in the water from the tray.

15

Air leaving the housing through the rear vents 20a first passes around the compressor 15, cooling the compressor.

Referring to Figs. 3 and 4, in a second embodiment of the invention, the components
20 are arranged in a similar manner to the first embodiment, except that the condenser and the condenser fan are re-located, as described below.

As in the first embodiment, the refrigeration apparatus is in the form of a removable cassette 22 located in the base of a refrigerated cabinet (not shown). An evaporator 24
25 is located beneath the central portion of the cabinet in an insulated enclosure 24a.

Evaporator fans 24b (Fig. 4 only) are mounted behind the evaporator. A compressor 25 is mounted at the rear of the cassette, with a condenser fan 26 alongside it.

A tray 28 is mounted along the base of the cassette, to collect the defrost water
30 draining through aperture 27 in the enclosure 24a. The condenser 23 is located in the tray 28 and may be either partially or fully submerged in the defrost water; a pipe 30 (Fig. 3 only) ducts the refrigerant gas from the compressor 25 to the condenser 23, where the gas is condensed back to liquid, giving up its heat of evaporation. This heat of evaporation is used to heat the defrost water in the tray 28. The liquid refrigerant is
35 returned to the evaporator 24 in known manner.

The defrost water in the tray 28 is also warmed and evaporated by the air drawn over the surface of the tray 28 by the condenser fan 26. As in the first embodiment, the cassette is sealed along top, base and sides, so that all the air drawn through the front vents 32 of the cassette passes over the surface of the water in the tray 28. This air flow is shown by double-headed arrows in Fig. 3 only. The air passes over the compressor 25, to cool it, before leaving the housing through the rear vents 32a. The positioning of the condenser 23 in the tray 28 has the additional advantage that, since the condenser is at least partially submerged in cold water, a much wider fin spacing can be used in the condenser, without compromising its function. This is a considerable practical advantage because condensers with the conventional narrow spacing (typically 315 fins/metre) are easily clogged with dust and dirt, and are a frequent cause of equipment failure/maintenance. In the present invention, it is believed that a fin spacing of 60 fins/metre will be acceptable; this should significantly reduce maintenance and increase efficiency.

Using heat exchange to simultaneously cool the condenser and evaporate the water significantly increases efficiency and reduces the energy consumption of the system.

In the embodiments shown in Figs. 5 and 6, only the lower portion of an open deck refrigeration cabinet is shown:- the upper portion of the cabinet is as shown in Fig. 1.

Referring in particular to Fig. 5 and 5a, the refrigeration apparatus consists of a condenser 38, an evaporator 37 in an insulated enclosure 39, a compressor 33 and pair of fans 34. The refrigeration apparatus is mounted in a housing 36 made as a removable cassette located in the base of a refrigeration cabinet; the top, the base and sides of the cassette are closed, so that the ambient air drawn through the cassette (indicated by the double headed arrows) must travel as indicated by those arrows, i.e. into the housing through the front vents 36a, over the surface of the tray 35 as discussed below, and out of the rear vents 36b.

The evaporator 37, compressor 33 and condenser 38 are interconnected by pipe work in known manner; this pipe work represents the standard refrigeration cycle and is omitted for clarity.

As in the embodiment described with reference to Figs. 3 and 4, the condenser 38 is mounted in a tray 35 which extends along the base of the cassette; the tray collects the defrost water draining through aperture 36 in the enclosure 39.

5 The compressor 33 is mounted at the rear of the cassette, and air is drawn through the front vents 36a of the cassette by the fan 34. Since the top, the base and sides of the cassette are closed, substantially all of the incoming air is forced to travel over the surface of the tray 35. Before leaving the housing through the rear vents 36b, the air passes around the compressor 33 to cool it.

10

This embodiment has the advantages of the embodiment described with reference to Figs. 3 and 4, but with the additional advantage that the fan 34 (which may be a single fan or multiple fans) blows air into the cassette rather than pulling air through the cassette:- the fan/fans have been found to be more effective working in this way.

15

Referring to Fig. 6, the refrigeration apparatus consists of a condenser 40 (shown as 40a, 40b and 40c as described below), an evaporator 41 in an insulated enclosure 42, compressor 43 and a fan 44. A tray 45 for catching the condensate trickling through the aperture 46 is located along the base of the cassette which, as in the other
20 embodiments, has a closed top, base and sides so that all incoming air (shown by double headed arrows) enters only through the front vents so, passes over the compressor 43 to cool it, then passes over the surface of the water in the tray 45, before leaving through the rear vents 51. As in the other embodiments, the refrigeration components are interconnected by pipe work of known type.

25

In this embodiment, the compressor 43 is located at the front of the cassette and the fan 44 (which, as in other embodiments, may be a single fan or multiple fans) is mounted at the rear of the cassette. The condenser 40 may be split, i.e. partly located adjacent the fan 44 as shown by reference 40a and/or located in the tray 45 as shown
30 by reference 40b and/or partly at the front as shown by reference 40c; alternatively, the condenser 40 can be located as a single condenser in any of these positions, or any combination thereof.

This embodiment has the advantages of the embodiment described with reference to
35 Figs. 3 and 4, but with the additional advantage that the incoming air is first drawn over

the surface of the tray 45 to evaporate the water in the tray, and thus will tend to be cooled by the evaporative cooling effect, so that the air which finally reaches the condenser 40a will be cooler than the ambient air. This will give an overall gain in efficiency.

5

THE CLAIMS DEFINING THE INVENTION ARE AS FOLLOWS:

1. Refrigeration apparatus which includes:
an evaporator, a compressor and a condenser, connected by pipework in known manner,
5 a fan, and a tray arranged to collect water during the defrost cycle of the apparatus; wherein:
- a) the tray provides a base and a wall surrounding the base;
 - b) at least the compressor, condenser, fan and tray are contained within a housing which is substantially closed except for air vents;
 - 10 c) at least part of the pipework between the compressor and the condenser is located within the tray;
 - d) the condenser is located in the tray such that at least a major portion of the condenser lies below the upper edge of the wall of the tray;
 - e) the fan, housing and tray are designed and arranged such that in use
15 the fan moves air through the housing so that substantially all of the air is directed over the surface of the tray.
2. The refrigeration apparatus as claimed in claim 1, wherein the condenser is provided with cooling fins having a spacing not more than 60 fins/metre.
20
3. The refrigeration apparatus as claimed in claim 1 or claim 2, wherein the fan is located at the front of the housing and is designed to blow air through the housing.
- 25 4. The refrigeration apparatus as claimed in claim 1 or claim 2, wherein the fan is located at the rear of the housing and is designed to draw air through the housing.
- 30 5. The refrigeration apparatus as claimed in any one of the preceding claims, wherein the evaporator also is contained within the housing, and the housing and its contents are designed as a removable cassette which can be withdrawn from the remainder of the refrigeration apparatus without dismantling the apparatus.

6. Refrigeration apparatus substantially as hereinbefore described with reference to and as shown in Figs. 3 and 4 or Figs. 5 and 5a of the accompanying drawings.

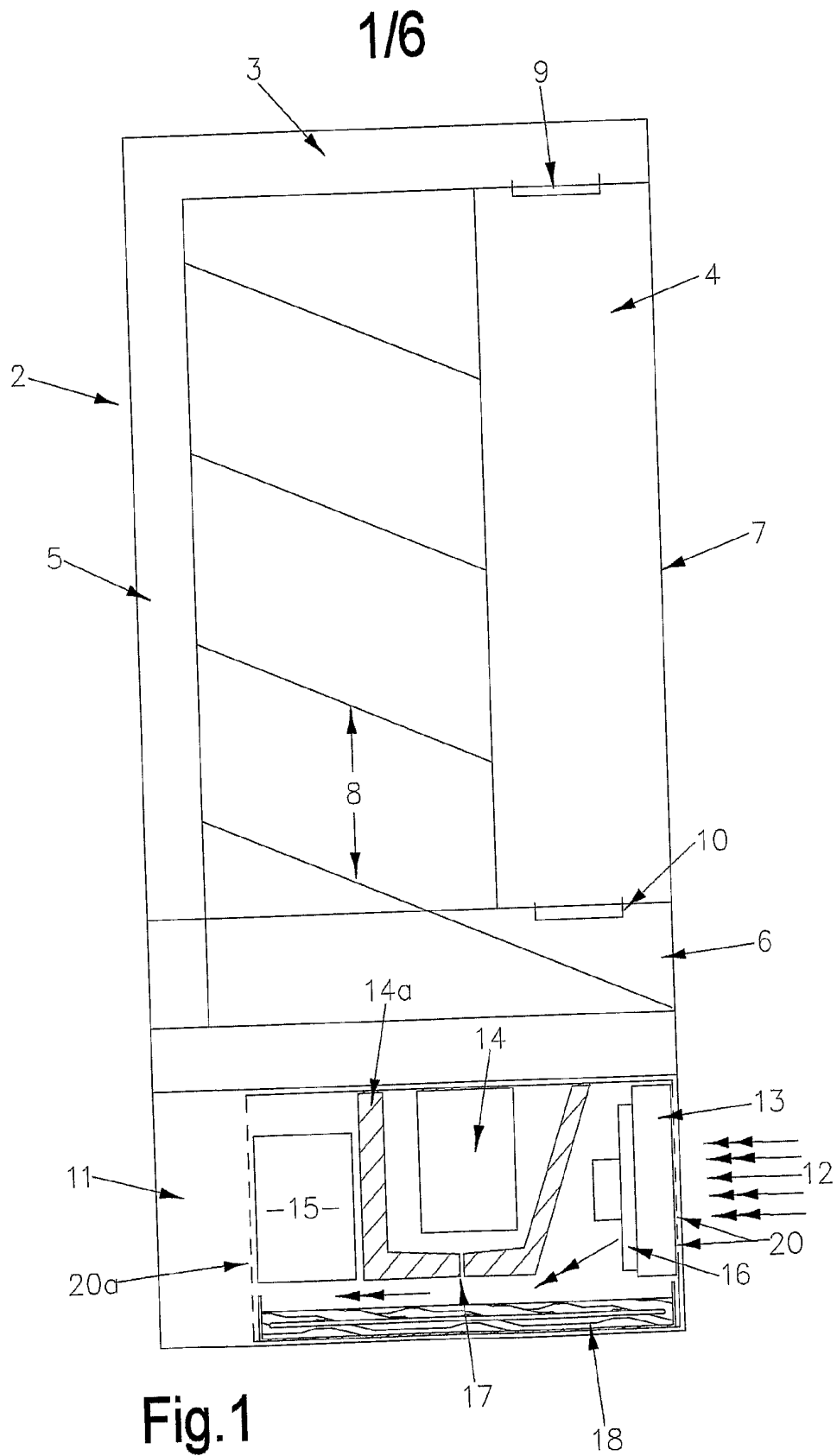

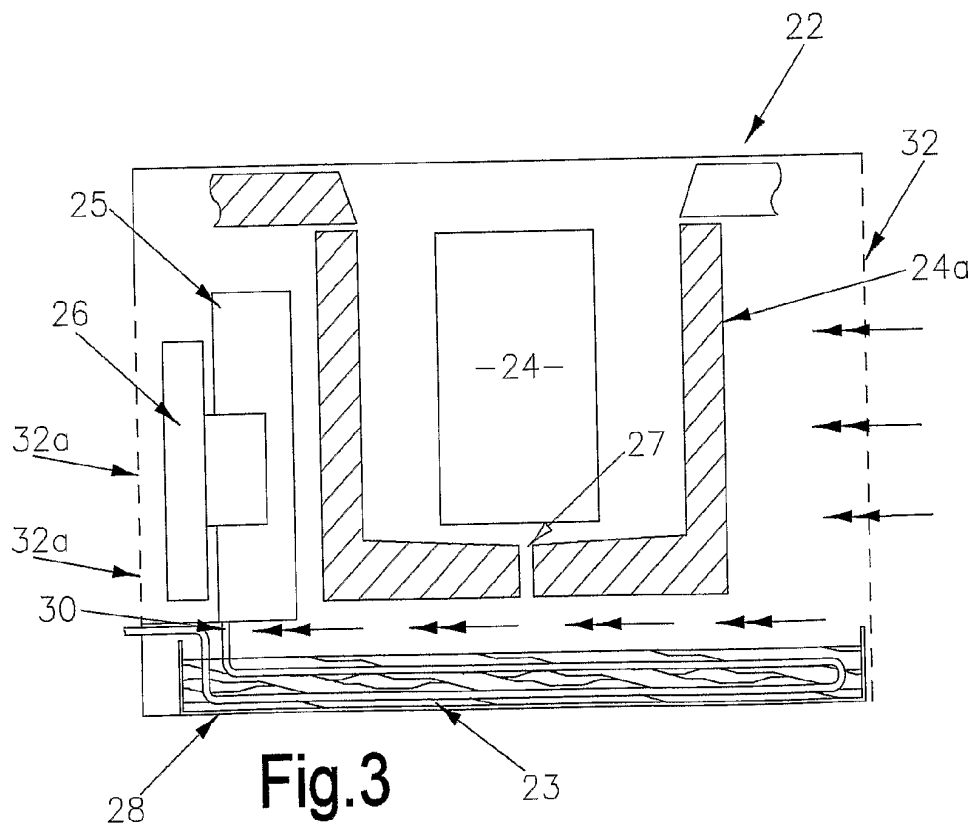
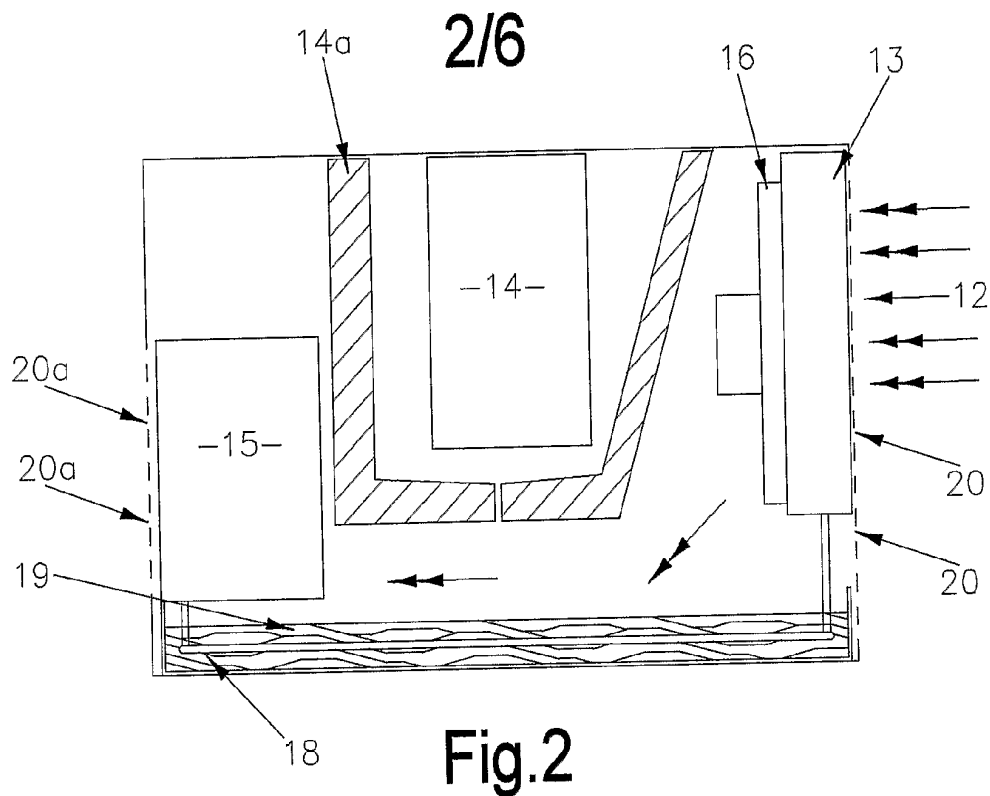
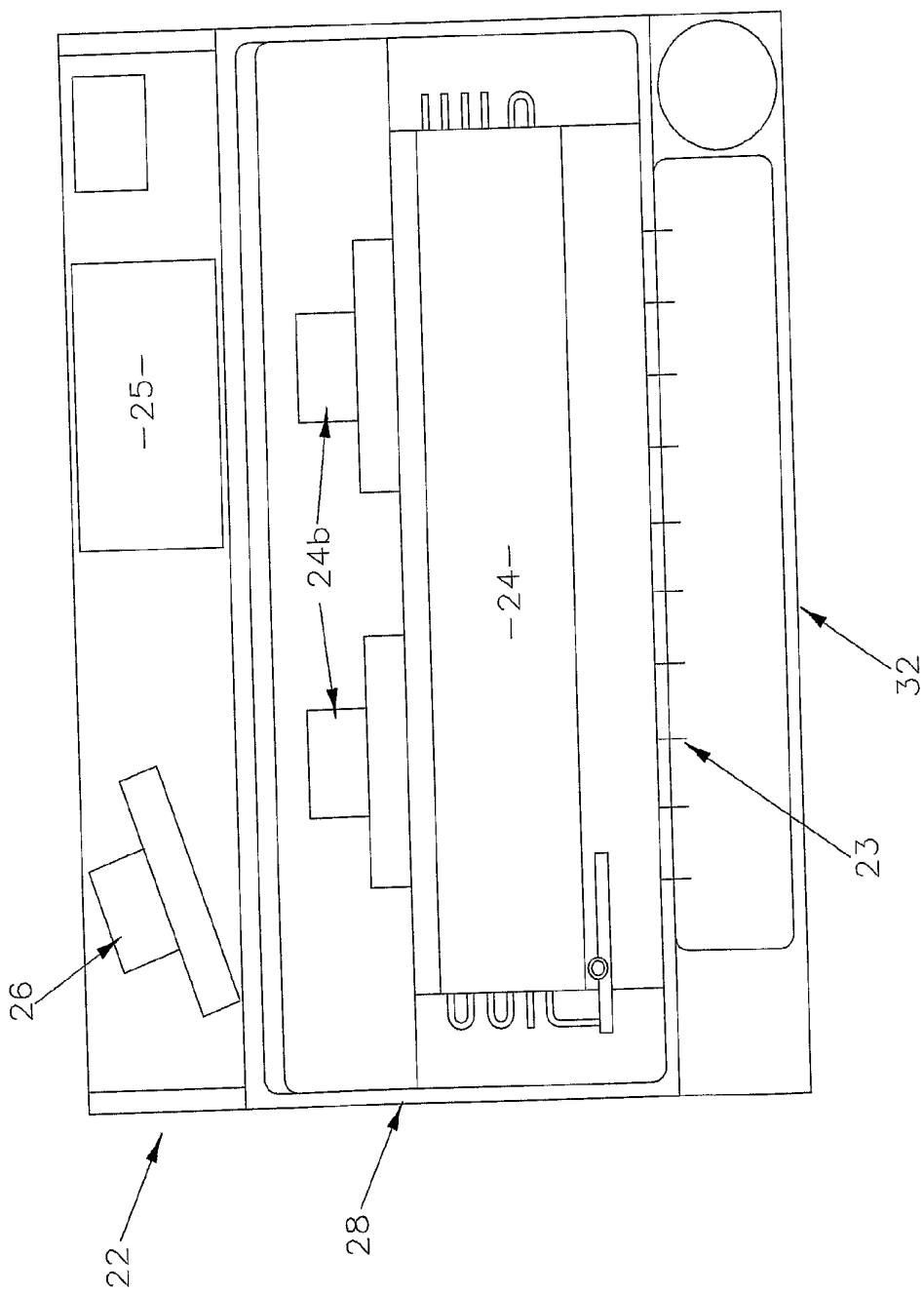

Fig. 4



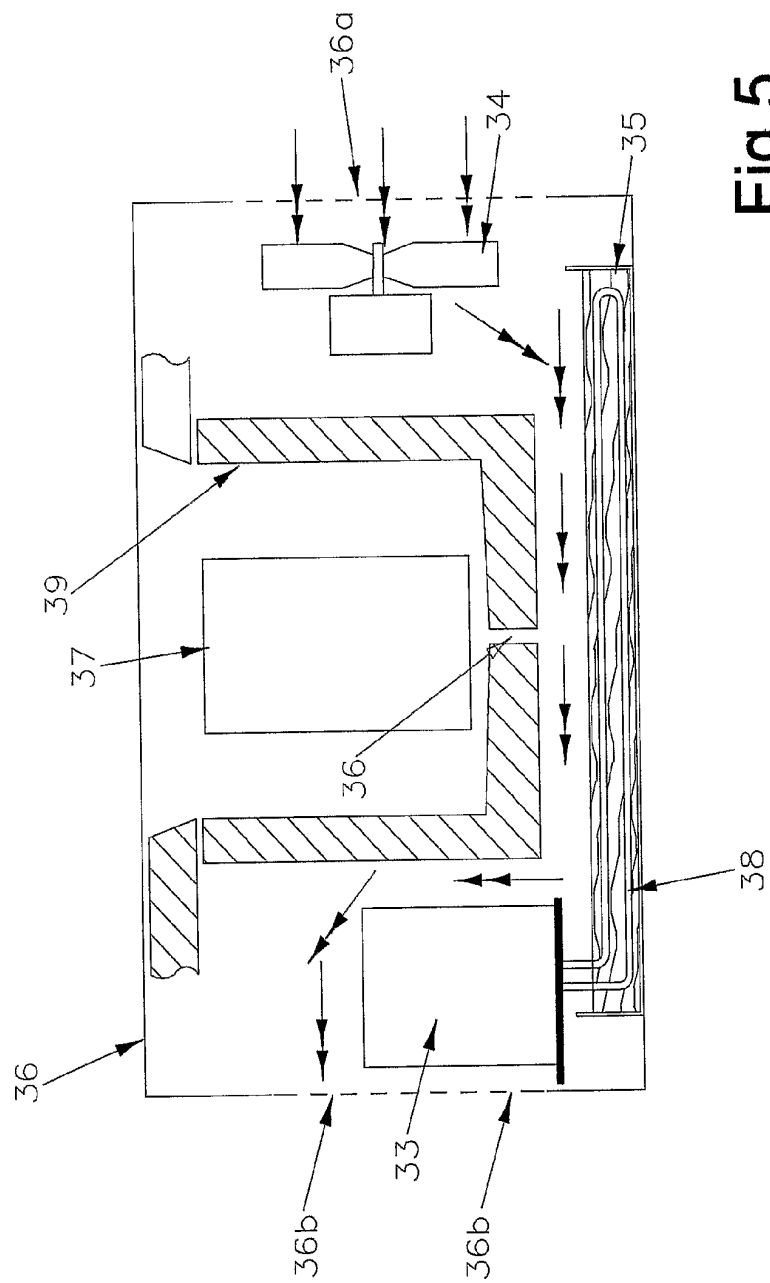

Fig.5

5/6

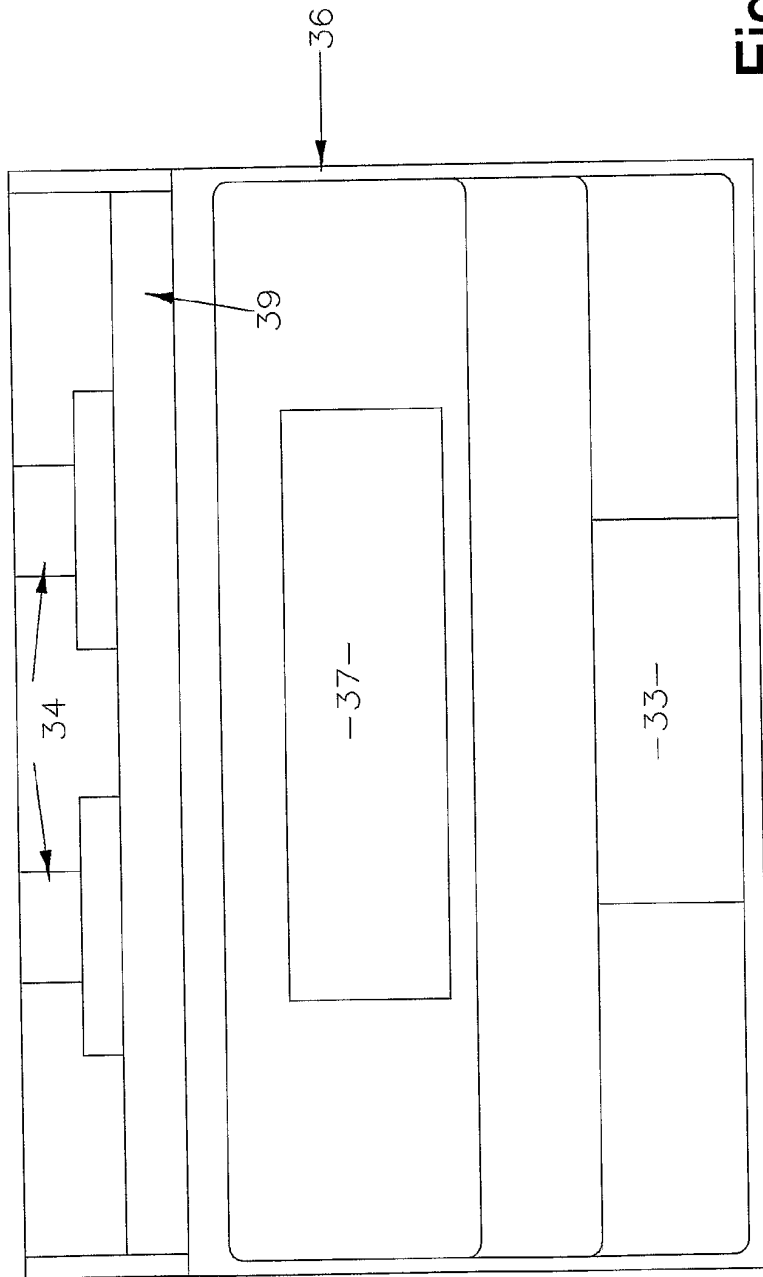

Fig. 5a

6/6

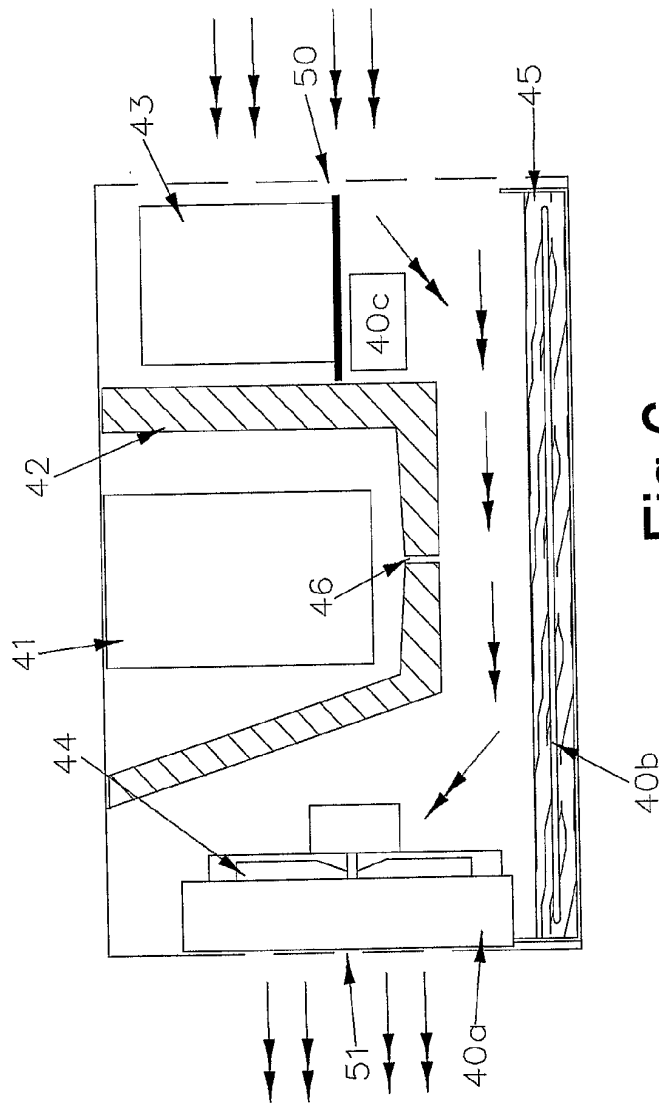

Fig.6