

Dec. 13, 1938.

F. A. DOLGE

2,139,809

FLATIRON HOLDER

Filed April 1, 1936

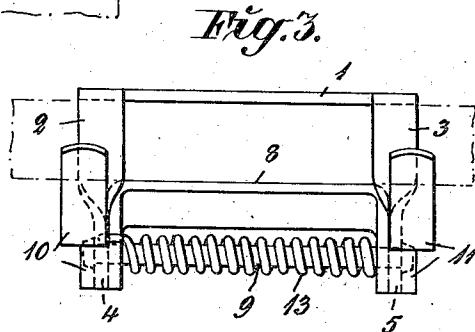
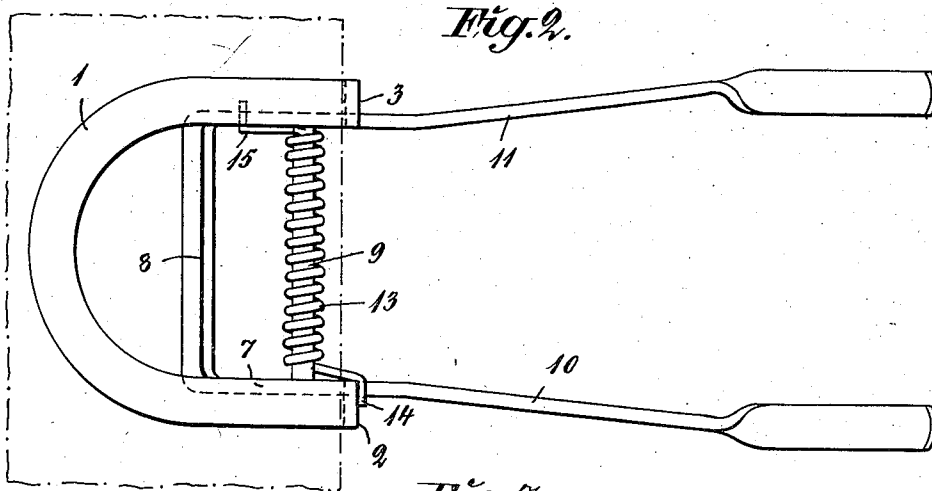
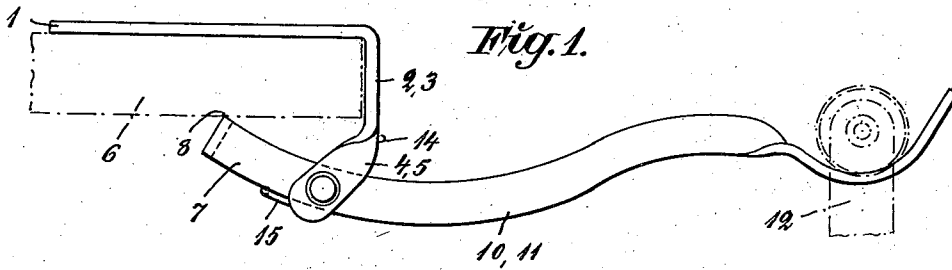

Frans Allen Dolge

By *Henry C. Parker*
Attorney

UNITED STATES PATENT OFFICE

2,139,809

FLATIRON HOLDER

Frans Allan Dolge, Eskilstuna, Sweden

Application April 1, 1936, Serial No. 72,199
In Sweden April 13, 1935

2 Claims. (Cl. 248—117.7)

The present invention has for its object an improvement in such flatiron holders as can be mounted through a simple operation at the edge of any table-top, ironing-board or the like whereby the flatiron can be suspended free in the air and the fire danger eliminated.

According to a preferred embodiment of the invention the holder comprises an upper member having a substantially plane bearing surface on its underside, two downward extensions integral with said upper member and shaped to leave a free space throughout underneath said bearing surface, a pivot mounted between said extensions underneath said bearing surface and at a distance therefrom, a lower member rotatable on said pivot and having a bearing point at its upper side inside said pivot, and a supporting arm extending outside said pivot and being integral with said lower member.

The invention will now be more particularly described with reference to the accompanying drawing illustrating a preferred method of carrying the invention into effect.

Figure 1 shows one embodiment of the invention in side view.

Figure 2 shows the same embodiment viewed from above, whereas Fig. 3 is a front view.

In the iron holder shown in Figs. 1 to 3 the upper member 1 is constituted by a horse-shoe shaped flat member. The end portions thereof are bent downwardly to form extensions 2, 4 and 3, 5 which have upper straight portions 2, 3 and lower twisted portions 4, 5 which lie in a plane perpendicular to the portions 2, 3. The extensions 2, 4 and 3, 5 are shaped to leave a free space throughout the underside of the member 1 and this space is adapted to accommodate the edge of a table-top or ironing-board 6. A lower member 7 is pivotally mounted upon a bolt 9 riveted at its ends to the elements 4, 5 and passing through holes in the member 7. The latter is fork-shaped and its base portion 8 acts at its upper side as a bearing zone against the underside of the table-top or the like 6.

The outer portion of the member 7 is adapted to form supporting arms 10, 11 for carrying a flat iron 12. The bolt 9 preferably carries a helical spring 13 which by its one end 14 is in engagement with the extension 2 and by its other end 15 passes beneath and engages the member 7. The spring tension tends to force the inner end of the member 7 towards the underside of the member 1 and thus to squeeze any slab 6 inserted therebetween. In the absence of the spring 13 a light touch on the underside of the arms 10, 11 would remove the device from the slab 6.

When applying the device to the slab the arms 10, 11 are swung against the spring action to increase the gap between the bearing portion 8 and the member 1 whereupon the device is pushed over the edge of the table-top, ironing-board or the like 6 and the arms 10, 11 are allowed to swing under spring pressure until the portion 8 firmly engages the slab 6. The arms 10, 11 then form a very rigid support for the flatiron 12 which may be put in position whenever required to be suspended freely as shown in the Figure 1.

It is to be understood that a preferred embodiment of the invention has been disclosed herein for purposes of illustration only and that various changes, substitutions and modifications may be made as will be apparent to a person skilled in the art. The invention is only to be limited in accordance with the following claims but interpreted in view of the prior art.

What is claimed is:—

1. A holding device for flatirons and the like comprising an upper member having a substantially plane bearing surface on its underside and provided with two spaced downward extensions integral with said upper member and shaped to leave a free space throughout underneath said bearing surface, a bolt mounted between said extensions underneath said bearing surface and at a distance therefrom, a lower member rotatable on said bolt provided with a bearing edge at its upper side inside said bolt and with a supporting arm extending outside said bolt, and a spring tending to swing the lower member with its bearing edge towards the bearing surface of said upper member.

2. A flatiron holder comprising an upper member having a substantially plane bearing surface on its underside provided with spaced downward extensions shaped to leave a free space throughout underneath said bearing surface, a pivot extending between and carried by said extensions underneath said bearing surface at a distance therefrom, a helical spring surrounding said pivot, a lower member rotatable on said pivot one end of which serves as a bearing edge at its upper side inside said pivot, the other end of said lower member extending outside said pivot and being shaped to form two spaced supporting arms adapted to receive an iron, said spring pressing with one end against one of said extensions and with its other end against said lower member to swing the latter with its bearing edge towards the upper member.

FRANS ALLAN DOLGE. 55